

FINAL REPORT

Passive Biobarrier for Treating Co-mingled Perchlorate and RDX
in Groundwater at an Active Range

ESTCP Project ER-201028

MAY 2016

Dr. Paul B. Hatzinger
Dr. Mark E. Fuller
CB&I Environmental, Inc.

Distribution Statement A
This document has been cleared for public release



Page Intentionally Left Blank

This report was prepared under contract to the Department of Defense Environmental Security Technology Certification Program (ESTCP). The publication of this report does not indicate endorsement by the Department of Defense, nor should the contents be construed as reflecting the official policy or position of the Department of Defense. Reference herein to any specific commercial product, process, or service by trade name, trademark, manufacturer, or otherwise, does not necessarily constitute or imply its endorsement, recommendation, or favoring by the Department of Defense.

Page Intentionally Left Blank

REPORT DOCUMENTATION PAGE			Form Approved OMB No. 0704-0188	
<p>The public reporting burden for this collection of information is estimated to average 1 hour per response, including the time for reviewing instructions, searching existing data sources, gathering and maintaining the data needed, and completing and reviewing the collection of information. Send comments regarding this burden estimate or any other aspect of this collection of information, including suggestions for reducing the burden, to the Department of Defense, Executive Services and Communications Directorate (0704-0188). Respondents should be aware that notwithstanding any other provision of law, no person shall be subject to any penalty for failing to comply with a collection of information if it does not display a currently valid OMB control number.</p> <p>PLEASE DO NOT RETURN YOUR FORM TO THE ABOVE ORGANIZATION.</p>				
1. REPORT DATE (DD-MM-YYYY) 05-12-2016	2. REPORT TYPE Final	3. DATES COVERED (From - To) May 2010 - November 2015		
4. TITLE AND SUBTITLE Passive Biobarrier for Treating Co-Mingled Perchlorate and RDX in Groundwater at an Active Range		5a. CONTRACT NUMBER W912-HQ-10-C-0051		
		5b. GRANT NUMBER NA		
		5c. PROGRAM ELEMENT NUMBER NA		
6. AUTHOR(S) Hatzinger, Paul B., Ph.D. Mark E. Fuller, Ph.D.		5d. PROJECT NUMBER ER-201028		
		5e. TASK NUMBER NA		
		5f. WORK UNIT NUMBER NA		
7. PERFORMING ORGANIZATION NAME(S) AND ADDRESS(ES) CB&I Federal Services, LLC. 17 Princess Road Lawrenceville, NJ 08648		8. PERFORMING ORGANIZATION REPORT NUMBER NA		
9. SPONSORING/MONITORING AGENCY NAME(S) AND ADDRESS(ES) Environmental Security Technology Certification Program 4800 Mark Center Drive, Suite 17D08 Alexandria, VA 22350-3605		10. SPONSOR/MONITOR'S ACRONYM(S) ESTCP		
		11. SPONSOR/MONITOR'S REPORT NUMBER(S) NA		
12. DISTRIBUTION/AVAILABILITY STATEMENT Distribution Statement A: Approved for Public Release, Distribution is Unlimited				
13. SUPPLEMENTARY NOTES None				
14. ABSTRACT A subsurface biobarrier consisting of emulsified vegetable oil and a buffering agent was tested to enhance biodegradation and reduce the migration of co-mingled RDX, HMX, and perchlorate in a shallow, acidic groundwater aquifer at an operational military range in Dahlgren, Va. Despite heterogeneous subsurface lithology and low hydraulic conductivity in the test site aquifer, RDX, HMX, and perchlorate were reduced by > 92 % in a centerline of monitoring wells extending 40 ft downgradient of the biobarrier when adequate total organic carbon (TOC) was present from the added oil. The accumulation of toxic nitroso- degradation products MNX, DNX, and TNX from RDX was minimal. Moreover, the passive biobarrier resulted in no significant impacts to ongoing range activities. This field trial suggests that an emulsified oil biobarrier is a viable alternative to reduce the migration of co-mingled perchlorate and explosives in groundwater at this and similar ranges. Ideal range locations include open OB/OD areas, target areas, fast cookoff sites, EOD training areas, and other locations where high munition constituent concentrations are possible.				
15. SUBJECT TERMS bioremediation, biodegradation, biobarrier, groundwater, RDX, HMX, perchlorate, buffer, range, migration				
16. SECURITY CLASSIFICATION OF:			17. LIMITATION OF ABSTRACT UU	18. NUMBER OF PAGES
a. REPORT U	b. ABSTRACT U	c. THIS PAGE U		
			19a. NAME OF RESPONSIBLE PERSON Dr. Paul B. Hatzinger	
			19b. TELEPHONE NUMBER (Include area code) 609-895-5356	

Reset

Standard Form 298 (Rev. 8/98)
Prescribed by ANSI Std. Z39.18

Page Intentionally Left Blank

Table of Contents

List of Figures.....	vii
List of Tables	xi
List of Appendices.....	xiii
List of Acronyms and Abbreviations	xiv
ACKNOWLEDGMENTS	xvi
EXECUTIVE SUMMARY	1
1.0. INTRODUCTION.....	6
1.1 BACKGROUND.....	6
1.2 OBJECTIVE OF THE DEMONSTRATION.....	6
1.3 REGULATORY DRIVERS	6
2.0. TECHNOLOGY	11
2.1 TECHNOLOGY DESCRIPTION.....	11
2.2 ADVANTAGES AND LIMITATIONS OF THE TECHNOLOGY	17
2.2.1 <i>Advantages</i>	17
2.2.2 <i>Limitations</i>	17
3.0. PERFORMANCE OBJECTIVES.....	18
3.1 EFFECTIVENESS OF RDX AND PERCHLORATE TREATMENT	20
3.1.1 <i>Data Requirements for RDX and Perchlorate Treatment</i>	20
3.1.2 <i>Success Criteria for RDX and Perchlorate Treatment</i>	20
3.2 ADEQUATE DISTRIBUTION OF EMULSIFIED OIL.....	20
3.2.1 <i>Data Requirements for Oil Distribution</i>	21
3.2.2 <i>Success Criteria for Oil Distribution</i>	21
3.3 GEOCHEMICAL CHANGES	21
3.3.1 <i>Data Requirements for Geochemical Changes</i>	21
3.3.2 <i>Success Criteria for Geochemical Changes</i>	21
3.4 BARRIER LONGEVITY.....	21
3.4.1 <i>Data Requirements for Barrier Longevity</i>	21
3.4.2 <i>Success Criteria for Barrier Longevity</i>	21
3.5 EASE OF BARRIER INSTALLATION.....	22
3.5.1 <i>Data Requirements for Barrier Installation & Operation</i>	22
3.5.2 <i>Success Criteria for Barrier Installation & Operation</i>	22
4.0. SITE DESCRIPTION.....	23
4.1 SITE SELECTION	23
4.2 SITE LOCATION AND HISTORY	23
4.3 SITE GEOLOGY AND HYDROGEOLOGY	24
4.3.1 <i>Basic Geology</i>	24
4.3.2 <i>Groundwater Monitoring Wells</i>	24
4.3.3 <i>Groundwater Depth</i>	30
4.3.4 <i>Groundwater Flow</i>	30
4.3.5 <i>Groundwater Chemistry</i>	33
4.4 CONTAMINANT DISTRIBUTION	34
4.5 TEST PLOT LOCATION	34
5.0. TEST DESIGN	38
5.1 CONCEPTUAL EXPERIMENTAL DESIGN	38

5.2	BASELINE CHARACTERIZATION ACTIVITIES	38
5.2.1	<i>Laboratory Treatability Studies</i>	39
5.2.1.1	Study Objectives	39
5.2.1.2	Sample Collection.....	39
5.2.1.3	Microcosm Study.....	41
	Microcosm Set-up.....	41
	Microcosm Sampling and Analysis	42
	Microcosm Results.....	43
5.2.1.4	Emulsified Oil Retention Testing	49
	Oil Retention Set-up	49
	Oil Retention Results	49
5.2.1.5	Column Biodegradation Testing.....	51
	Column Design and Set-up.....	51
	Column Results.....	52
	Summary of Column Study Results.....	55
5.2.1.6	Conclusions from the Treatability Studies.....	67
5.2.2	<i>Field Characterization</i>	68
5.2.2.1	Rationale	68
5.2.2.2	Test Site Geology.....	69
5.2.2.3	Groundwater Chemistry.....	70
5.2.2.4	Test Site Groundwater Flow and Direction.	71
5.2.2.5	Explosives and Perchlorate in Test Site Groundwater.....	79
5.2.3	<i>Selection of Biobarrier Location</i>	79
5.3	DESIGN AND LAYOUT OF FIELD DEMONSTRATION COMPONENTS	85
5.3.1	<i>Demonstration Layout</i>	85
5.3.2.1	Biobarrier Design.....	85
5.3.2.2	Biobarrier Injection Well and Monitoring Well Installation	85
5.3.2.3	Baseline Sampling	86
5.3.2.4	Biobarrier Installation	86
5.4	FIELD TESTING	92
5.4.1	<i>Biobarrier Monitoring</i>	92
5.4.2	<i>Analysis of RDX Degrading Bacteria</i>	92
5.4.3	<i>System Shutdown and Demobilization</i>	92
5.5	SAMPLING PLAN	93
5.5.1	<i>Groundwater Sampling</i>	93
5.5.2	<i>Analytical</i>	94
5.5.3	<i>Quality Assurance for Groundwater Sampling and Analysis</i>	94
5.5.3.1	Calibration Procedures and Frequency.	94
5.5.3.2	Field Measurements: Groundwater.....	94
5.5.3.3	Laboratory Measurements.	94
5.5.3.4	Quality Control Samples.....	95
5.5.3.5	Sample Documentation.....	98
5.5.3.6	Sample Identification.....	98
5.5.3.7	Laboratory Sample Receipt.....	98
5.5.3.8	Other Documentation.....	99
5.6	DATA ANALYSES	101

6.0. DEMONSTRATION RESULTS	102
6.1 PROCESS PARAMETERS	102
6.1.1 <i>Precipitation, Depth to Water, and Groundwater Temperature.....</i>	<i>102</i>
6.1.2 <i>Dissolved Oxygen (DO) and Oxidation Reduction Potential (ORP).....</i>	<i>107</i>
6.1.3 <i>pH.....</i>	<i>112</i>
6.1.4 <i>Total Organic Carbon (TOC).....</i>	<i>112</i>
6.1.5 <i>Anions</i>	<i>117</i>
6.1.6 <i>Dissolved Gases</i>	<i>117</i>
6.2 TARGET ANALYTES	124
6.2.1 <i>RDX, HMX, and metabolites.....</i>	<i>124</i>
6.2.1.1 <i>RDX and metabolite concentrations</i>	<i>124</i>
6.2.1.2 <i>RDX degradation rates.....</i>	<i>125</i>
6.2.1.3 <i>HMX concentrations.....</i>	<i>126</i>
6.2.1.4 <i>HMX degradation rates.....</i>	<i>126</i>
6.2.2 <i>Perchlorate</i>	<i>127</i>
6.2.2.1 <i>Perchlorate concentrations</i>	<i>127</i>
6.2.2.2 <i>Perchlorate degradation rates.....</i>	<i>127</i>
6.3 GROUNDWATER QUALITY ANALYTES	146
6.3.1 <i>Dissolved Metals.....</i>	<i>146</i>
6.4 QUALITY CONTROL RESULTS	150
6.5 MICROBIOLOGICAL RESULTS	152
7.0. PERFORMANCE ASSESSMENT.....	159
7.1 PERFORMANCE OBJECTIVES	159
7.2 EFFECTIVENESS OF RDX AND PERCHLORATE TREATMENT	166
7.2.1 <i>Data Requirements for RDX and Perchlorate Treatment.....</i>	<i>166</i>
7.2.2 <i>Success Assessment for RDX and Perchlorate Treatment.....</i>	<i>166</i>
7.2.3 <i>Overall Assessment for RDX and Perchlorate Treatment</i>	<i>168</i>
7.3 ADEQUATE DISTRIBUTION OF EMULSIFIED OIL.....	172
7.3.1 <i>Data Requirements for Oil Distribution</i>	<i>172</i>
7.3.2 <i>Success Assessment for Oil Distribution.....</i>	<i>172</i>
7.3.3 <i>Overall Assessment for Oil Distribution.....</i>	<i>172</i>
7.4 GEOCHEMICAL CHANGES	173
7.4.1 <i>Data Requirements for Geochemical Changes.....</i>	<i>173</i>
7.4.2 <i>Success Assessment for Geochemical Changes</i>	<i>173</i>
7.4.3 <i>Overall Assessment for Geochemical Changes</i>	<i>174</i>
7.5 BARRIER LONGEVITY.....	175
7.5.1 <i>Data Requirements for Barrier Longevity.....</i>	<i>175</i>
7.5.2 <i>Success Assessment for Barrier Longevity</i>	<i>175</i>
7.5.3 <i>Overall Assessment for Barrier Longevity.....</i>	<i>175</i>
7.6 EASE OF BARRIER INSTALLATION.....	176
7.6.1 <i>Data Requirements for Barrier Installation & Operation.....</i>	<i>176</i>
7.6.2 <i>Success Assessment for Barrier Installation & Operation</i>	<i>176</i>
7.6.3 <i>Overall Assessment for Ease of Barrier Installation</i>	<i>176</i>
8.0. COST ASSESSMENT	176
8.1 COST MODEL.....	177
8.1.1 <i>Capital Costs.....</i>	<i>179</i>

8.1.2	<i>O&M Costs</i>	179
8.1.3	<i>Demonstration-Specific Costs</i>	179
8.2	COST DRIVERS	179
8.2.1	<i>General Considerations</i>	179
8.2.2	<i>Competing Treatment Technologies</i>	180
8.3	COST ANALYSIS	181
8.3.1	<i>Base Case Template</i>	182
8.3.2	<i>Semi-Passive Biobarrier</i>	184
8.3.3	<i>Passive Injection Biobarrier</i>	186
8.3.4	<i>Passive Trench Mulch Biowall</i>	188
8.3.5	<i>Passive Trench ZVI PRB</i>	190
8.3.6	<i>Active Pump and Treat</i>	192
9.0.	IMPLEMENTATION ISSUES	194
9.1	END-USER IMPLEMENTATION ISSUES	194
9.1.1	<i>Technology Applicability and Performance</i>	194
9.1.2	<i>Specific Implementation Issues at the Dahlgren NSWC Site</i>	196
9.1.3	<i>Technology Scale-up.</i>	196
9.1.4	<i>Technology Cost Compared to Other Remedial Options</i>	197
10.0.	REFERENCES	198

List of Figures

Figure 2.1.	Combined treatment of perchlorate, RDX, and HMX in flow-through columns containing aquifer solids from a US Navy site.	13
Figure 2.2.	Biological degradation of perchlorate (A) and RDX (B) in microcosms.	14
Figure 2.3.	Disposition of emulsified oil after injection into groundwater as a function of time.	15
Figure 2.4.	Schematic of generalized biobarrier design and monitoring well network.	16
Figure 4.1.	Location of the Dahlgren site.....	25
Figure 4.2.	Map showing the main areas of NSWC Dahlgren.....	26
Figure 4.3.	Map showing the Churchill Range of NSWC Dahlgren.....	27
Figure 4.4.	Schematic of the geologic and hydrogeologic units of the EEA.	28
Figure 4.5.	Map showing permanent well locations on the Churchill Range of NSWC Dahlgren.....	29
Figure 4.6.	Potentiometric surface map of the Churchill Range Area in Spring, 2007.	31
Figure 4.7.	Estimated hydraulic conductivity distribution in the Columbia Aquifer.....	32
Figure 4.8.	Potentiometric surfaces and modeled groundwater flow pathways from the Open Burn, Open Detonation, and Fast Cookoff areas on the Churchill Range.....	36
Figure 4.9.	Modeled plume migration maps for RDX and perchlorate.	37
Figure 5.1.	Sampling locations for preliminary site assessment and laboratory treatability testing.....	40
Figure 5.2.	Degradation of HMX, RDX and perchlorate in aquifer microcosms.	45
Figure 5.3.	Detection of MNX, DNX, and TNX in the site-derived microcosms.	46
Figure 5.4.	Measured pH in the site-derived microcosms over time.	47
Figure 5.5.	Measured pH over time in site groundwater amended with various mixtures of the emulsified oil products.....	48
Figure 5.6.	Residual oil retention as a function of distance from injection point.	50
Figure 5.7.	Column design for laboratory treatability testing.	56
Figure 5.8.	Bromide tracer results for the three flow-through columns.....	57
Figure 5.9.	The pH in the influent groundwater and the effluent of the three flow-through columns.	58
Figure 5.10.	Dissolved oxygen in the influent groundwater and the effluent of the three flow-through columns.....	58
Figure 5.11.	TOC in the influent groundwater and the effluent of the three flow-through columns.	59

Figure 5.12.	Nitrate and sulfate in the influent groundwater and the effluent of the three flow-through columns.....	60
Figure 5.13.	Perchlorate in the influent groundwater and the effluent of the three flow-through columns.	61
Figure 5.14.	HMX in the influent groundwater and the effluent of the three flow-through columns.	62
Figure 5.15.	RDX in the influent groundwater and the effluent of the three flow-through columns.	62
Figure 5.16.	MNX, DNX, and TNX in the influent groundwater and the effluent of the three flow-through columns.	63
Figure 5.17.	Profile of one Geoprobe core from the Dahlgren site showing significant amounts of iron minerals (orange).	64
Figure 5.18.	Profiles of RDX and perchlorate as a function of distance from the influent end of the columns.	65
Figure 5.19.	Profiles of nitrate and sulfate as a function of distance from the influent end of the columns.	66
Figure 5.20.	Map showing the well and piezometer locations on the Churchill Range of NSWC Dahlgren (November 2011).	73
Figure 5.21.	Stratigraphic diagram of the area surrounding monitoring well CMOBOD02.	74
Figure 5.22.	Potentiometric surface map of the Churchill Range in May 2011.....	75
Figure 5.23.	Potentiometric surface map of the Churchill Range in October 2011.	76
Figure 5.24.	Dissolved oxygen contours in the southeast area of the Churchill Range.....	77
Figure 5.25.	pH contours in the southeast area of the Churchill Range.....	78
Figure 5.26.	RDX, HMX and perchlorate data from piezometers installed during the May 2011 site investigation.	81
Figure 5.27.	Plume map for RDX in the southeast area of the Churchill Range.	82
Figure 5.28.	Plume map for perchlorate in the southeast area of the Churchill Range.....	83
Figure 5.29.	Plume map for HMX in the southeast area of the Churchill Range.	84
Figure 5.30.	Summary of emulsified oil biobarrier design parameters.....	88
Figure 5.31.	Schematic of demonstration plot layout.	91
Figure 5.32.	Example groundwater parameter stabilization form for low flow sampling.	96
Figure 5.33.	Chain of Custody (COC) form used by CB&I’s analytical laboratory.....	100
Figure 6.1.	Precipitation (in inches) received in the demonstration site area.	104
Figure 6.2.	Depth to the water table (feet below the top of the well casing (TOC)) along the centerline of the demonstration plot.	105
Figure 6.3.	Groundwater temperatures during the demonstration period.	106

Figure 6.4.	Dissolved oxygen concentrations along the demonstration plot centerline.....	108
Figure 6.5.	Dissolved oxygen concentrations over time in the demonstration plot.	109
Figure 6.6.	Oxidation-reduction potential along the demonstration plot centerline.	110
Figure 6.7.	Oxidation-reduction potential over time in the demonstration plot.....	111
Figure 6.8.	Groundwater pH along the demonstration plot centerline.....	113
Figure 6.9.	Groundwater pH over time in the demonstration plot.	114
Figure 6.10.	TOC in groundwater along the demonstration plot centerline.....	115
Figure 6.11.	TOC in groundwater over time in the demonstration plot.....	116
Figure 6.12.	Nitrate and sulfate concentrations in groundwater over time.	118
Figure 6.13.	Nitrate and sulfate concentrations at various locations in the demonstration plot relative to the upgradient concentrations over time.....	120
Figure 6.14.	Dissolved methane along the centerline of the demonstration plot.	122
Figure 6.15.	Dissolved methane concentrations groundwater over time.	123
Figure 6.16.	RDX along the centerline of the demonstration plot.	129
Figure 6.17.	RDX concentrations groundwater over time.	130
Figure 6.18.	RDX concentrations at various locations in the demonstration plot relative to the upgradient concentrations over time.....	131
Figure 6.19.	RDX metabolite concentrations groundwater over time at various locations. ...	132
Figure 6.20.	RDX metabolite concentrations groundwater over time in the barrier and along the centerline.....	133
Figure 6.21.	RDX degradation rates over time.	134
Figure 6.22.	RDX degradation rate using data from upgradient well MW-10 versus all three in-barrier monitoring wells.....	135
Figure 6.23.	HMX along the centerline of the demonstration plot.	136
Figure 6.24.	HMX concentrations groundwater over time.	137
Figure 6.25.	HMX concentrations at various locations in the demonstration plot relative to the upgradient concentrations over time.....	138
Figure 6.26.	HMX degradation rates over time.....	139
Figure 6.27.	HMX degradation rate using data from upgradient well MW-10 versus all three in-barrier monitoring wells.....	140
Figure 6.28.	Perchlorate concentration along the centerline of the demonstration plot.....	141
Figure 6.29.	Perchlorate concentrations in groundwater over time.	142
Figure 6.30.	Perchlorate concentrations at various locations in the demonstration plot relative to the upgradient concentrations over time.....	143
Figure 6.31.	Perchlorate degradation rates over time.....	144

Figure 6.32.	Perchlorate degradation rate using data from upgradient well MW-10 versus all three in-barrier monitoring wells.	145
Figure 6.33.	Dissolved iron concentrations over time.....	147
Figure 6.34.	Dissolved manganese concentrations over time.	148
Figure 6.35.	Dissolved arsenic concentrations over time.....	149
Figure 6.36.	RDX degradation and RDX metabolite formation, under different electron accepting conditions.....	156
Figure 6.37.	Phylogenetic tree representing 16S rRNA gene sequences derived from ¹³ C-DNA fractions of microcosms receiving ¹³ C3-labeled RDX under different electron acceptor conditions.	157
Figure 6.38.	Phylogenetic tree representing 16S rRNA gene sequences derived from ¹⁵ N-DNA fractions of microcosms receiving ¹⁵ N-labeled RDX (ring- or nitro- ¹⁵ N ₃ -RDX, and fully-labeled ¹⁵ N ₆ -RDX) under different electron acceptor conditions.	158
Figure 8.1.	Base case plume characteristics (modified from Krug et al., 2009).	183
Figure 8.2.	Semi-passive biobarrier alternative with cheese whey for plume cutoff.....	185
Figure 8.3.	Passive injection biobarrier alternative with EVO for plume cutoff.	187
Figure 8.4.	Passive biobarrier alternative utilizing a mulch biowall for plume cutoff.....	189
Figure 8.5.	Passive permeable reactive barrier alternative utilizing ZVI for plume cutoff. .	191

List of Tables

Table 1.1.	Virginia Groundwater Protection Standards.....	7
Table 3.1.	Performance objectives.....	18
Table 4.1.	Summary of historical water quality data from the Columbia Aquifer in the EEA.	33
Table 4.2.	Observed historical groundwater perchlorate concentrations in the Churchill Range (2003-2010).....	35
Table 4.3.	Observed historical groundwater RDX concentrations in the Churchill Range (1998-2010).....	35
Table 5.1.	Emulsified oil products evaluated in treatability tests.....	41
Table 5.2.	Key components of emulsified oil products.....	41
Table 5.3.	Quantities of emulsified oil products in microcosms.....	42
Table 5.4.	Mass balance for the oil retention testing.....	50
Table 5.5.	Treatment assignments for the column testing.....	52
Table 5.6.	Apparent steady-state degradation rates of target compounds.....	53
Table 5.7.	Metal concentrations in column effluent after emulsified oil amendment.....	55
Table 5.8.	Water quality data from four permanent wells on the Churchill Range.....	70
Table 5.9.	Initial emulsified oil injection logs (February 2013).....	89
Table 5.10.	Second emulsified oil injection logs (October 2014).....	90
Table 5.11.	Sampling and field events schedule.....	93
Table 5.12.	Analytical methods and total samples collected during the field demonstration..	97
Table 6.1.	Practical quantitation limits for laboratory analyses.....	103
Table 6.2.	Comparison of sample and duplicate analytical results for key analytes during the demonstration.....	151
Table 7.1.	Performance objective assessment.....	160
Table 7.2.	Statistical analysis output for upgradient vs. downgradient RDX.....	169
Table 7.3.	Statistical analysis output for upgradient vs. downgradient HMX.....	170
Table 7.4.	Statistical analysis output for upgradient vs. downgradient perchlorate.....	171
Table 8.1.	Demonstration cost components.....	178
Table 8.2.	Summary of base case site characteristics and design parameters for treatment of explosives-impacted groundwater.....	183
Table 8.3.	Cost components for semi-passive biobarrier treatment of explosives-impacted groundwater.....	185

Table 8.4.	Cost components for passive injection biobarrier treatment of explosives-impacted groundwater.	187
Table 8.5.	Cost components for passive trench biowall treatment of explosives-impacted groundwater.	189
Table 8.6.	Cost components for passive trench ZVI PRB treatment of explosives-impacted groundwater.	191
Table 8.7.	Cost components for extraction and treatment of explosives-impacted groundwater.	193
Table 8.8.	Summary of capital costs and NPV of costs for O&M and monitoring for treatment of explosives-impacted groundwater.	193

List of Appendices

Appendix A. Soil Boring Logs

Appendix B. Groundwater Elevation Data

Appendix C. In Situ Water Level Datalogger (Troll) and Slug Testing Data

Appendix D. Biobarrier Design Information (Emulsified Oil Design Tool input/output)

Appendix E. Field Sampling Methods

Appendix F. Analytical Methods

Appendix G. Analytical Results

List of Acronyms and Abbreviations

Acronym	Full text
ACL	alternate concentration limit
Ag	silver
amsl	above mean sea level
As	arsenic
Be	beryllium
bgs	below ground surface
BOD	biological oxygen demand
Br	bromide
°C	degrees Celsius
C	carbon
CaCO ₃	calcium carbonate
Cd	cadmium
Cl ⁻	chloride
ClO ₄ ⁻	perchlorate
cm	centimeters
cm ³	cubic centimeters
Co	cobalt
COC	chain of custody
Cr	chromium
d	days
DEQ	Department of Environmental Quality
DNA	deoxyribonucleic acid
DNTs	dinitrotoluenes
DNX	hexahydro-1,3-dinitroso-5-nitro-1,3,5-triazine
DO	dissolved oxygen
DoD	Department of Defense
DPT	direct-push technology
EEA	Explosives Experimental Area
EOD	explosive ordnance disposal
EOS	emulsified oil substrate
ESTCP	Environmental Security Technology Certification Program
EtOH	ethanol (ethyl alcohol)
EVO	emulsified vegetable oil
Fe	iron
ft	foot
g	grams
GAC	granular activated carbon
GC-IRMS	gas chromatography-isotope ratio mass spectrometry
Hg	mercury
HMX	octahydro-1,3,5,7-tetranitro-1,3,5,7-tetrazocine
HPLC	High performance liquid chromatography
ID	inner diameter
IHDIVNSWC	Indian Head Division Naval Surface Warfare Center
IW	injection well
L	liters
K	hydraulic conductivity; sorption coefficient
µg/L	micrograms per liter
mg/kg	milligrams per kilogram

mg/L	milligrams per liter
mL	milliliters
m	meters
MDL	method detection limit
Mn	manganese
MNX	hexahydro-1-nitroso-3,5-dinitro-1,3,5-triazine
mV	millivolts
MW	monitoring well
N	nitrogen
NPV	net present value
NSWC	Naval Surface Airfare Center
OB/OD	open burn/open detonation
ORP	oxidation-reduction potential
O&M	operation and maintenance
Pb	lead
PCR	polymerase chain reaction
PDA	photodiode array
PQL	practical quantitation limit
PRB	permeable reactive barrier
PV	pore volume
PVC	polyvinyl chloride
P&T	pump and treat
QA	quality assurance
RDT&E	Research, Development, Test, and Evaluation
RDX	hexahydro-1,3,5-trinitro-1,3,5-triazine
REAMS	Risk Exposure and Analysis Modeling System
RPD	relative percent difference
Sb	antimony
Se	selenium
SERDP	Strategic Environmental Research and Development Program
SIP	stable isotope probing
SMCL	secondary maximum contaminant level
SO ₄ ⁻	sulfate
SPE	solid phase extraction
TAL	target analyte list
tRFLP	terminal restriction fragment length polymorphism
TNT	2,4,6-trinitrotoluene
TNX	hexahydro-1,3,5-trinitroso-1,3,5-triazine
TOC	total organic carbon
USCS	Unified Soil Classification System
USEPA/EPA	U. S. Environmental Protection Agency
UV	ultraviolet
UXO	unexploded ordnance
V	vanadium
VFA	volatile fatty acid
VGWS	Virginia Department of Environmental Quality Groundwater Standard
VOA	volatile organic analysis
VOC	volatile organic compounds
v/v	volume to volume
wt	weight
ZVI	zero-valent iron

ACKNOWLEDGMENTS

We wish to thank the environmental staff at the Naval Surface Warfare Center, Dahlgren, VA for their support during this demonstration. In particular, special thanks to Jeanne Hartzell, Jeff Hughes, Bethany Brown, and Macon Patteson for their consistent dedication to the project and its success. We also wish to thank ESTCP for their financial support, and Dr. Andrea Leeson, the Environmental Restoration Program Manager at ESTCP for her guidance. Finally, we wish to acknowledge the capable staff at CB&I that conducted site assessment, laboratory studies, system design, well installation, substrate injection, groundwater sampling, and analytical support. In particular, Randi Rothmel, Sheryl Streger, Christina Andaya, Charles Condee, David Lippincott, Jeff Hillebrand, Paul Hedman, and Emily Tucker of CB&I were vital to project success. Their efforts ultimately lead to the quality experimental results and findings demonstrated during this project.

EXECUTIVE SUMMARY

Perchlorate, hexahydro-1,3,5-trinitro-1,3,5-triazine (RDX), and octahydro-1,3,5,7-tetranitro-1,3,5,7-tetrazocine (HMX) are common and often co-mingled contaminants in soils and groundwater at military ranges worldwide. These contaminants are mobile and persistent in groundwater under aerobic conditions. Although multiple studies have demonstrated in situ biodegradation of nitramine explosives (RDX, HMX) and perchlorate individually under anaerobic conditions, remediation of co-mingled plumes has not been reported. This field demonstration project was undertaken to investigate the feasibility of using a passive emulsified oil biobarrier to remediate co-mingled perchlorate, RDX, and HMX at the Naval Surface Warfare Center, Dahlgren in Dahlgren, VA (Dahlgren, NSWC). The remedial approach was designed specifically to minimize impacts to ongoing range activities.

Groundwater in some areas of the United States, including the aquifer underlying the Dahlgren testing range, is naturally acidic, which can slow or prevent the biodegradation of many contaminants, including perchlorate and explosives. In these environments, groundwater pH must be neutralized and buffered to promote robust biodegradation. During this study, groundwater pH was adjusted in addition to adding emulsified oil in order to form an effective in situ biobarrier.

Laboratory microcosm and column experiments were conducted with site sediment and groundwater in order to select the most effective emulsified oil and buffering amendments, and to derive parameters required for biobarrier design. Microcosm studies indicated that a specific emulsified oil (EOS 550LS) plus a slow release buffering agent (CoBupH) was the most effective substrate for promoting the biodegradation of all three target contaminants. Perchlorate degraded most quickly and HMX most slowly. In addition, the data showed that all three target contaminants could be biodegraded to very low concentrations (e.g., <0.5 µg/L for RDX and perchlorate and <10 µg/L for HMX) within a 60 day timeframe. Laboratory-scale columns packed with subsurface sediment from the range generally supported the microcosm results. Reductions of effluent perchlorate and RDX concentrations of greater than 95%, and reductions in HMX concentrations by 50 to >80% were observed during these studies.

A laboratory study was also conducted in which ¹⁵N- or ¹³C-labeled RDX was added to Dahlgren site groundwater and sediment slurries incubated under different electron accepting conditions (Fe-reducing, Mn-reducing, sulfate-reducing or methanogenic). The organisms responsible for degrading RDX (or its intermediates) were then evaluated by identifying those that incorporated ¹⁵N or ¹³C from the labeled RDX into their DNA, a technique known as stable isotope probing (SIP). Three major microbial groups in *α-Proteobacteria* (unclassified *Rhizobiales*), *γ-Proteobacteria* (*Pseudomonas*), and *Clostridia* (*Desulfosporosinus*) were present and responsible for RDX and/or RDX-intermediate degradation under the various electron-accepting conditions. *Desulfosporosinus* species, which are known for their adaptable metabolism, were detected under each of the different electron-accepting conditions where RDX degradation was observed. The detection of *Pseudomonas* sp. during this study under differing geochemical conditions, and with both C and N SIP, similarly highlights the wide diversity of this genus, and their importance in many environmental processes. The data from this laboratory study also showed much lower

accumulation of nitroso-containing intermediates from RDX during incubation under sulfate-reducing or methanogenic conditions compared to Fe- or Mn-reducing conditions.

The laboratory experiments supported design of a field-scale trial using a passive 100 ft biobarrier composed of a buffered emulsified oil. The demonstration plot consisted of 20 emulsified oil/buffer injection wells (IW) spaced in a single row on five foot centers, three of which served as in-barrier monitoring wells after injection. The main monitoring well network consisted of one upgradient monitoring well (MW) and six downgradient monitoring wells, spaced from 10 ft upgradient to 40 ft downgradient of the biobarrier along the centerline of the expected groundwater flow. An additional seven monitoring wells were emplaced on either side of the centerline within and on the edge of the expected zone of influence of the injected emulsified oil. Existing well CMOBODO2, which was ~ 50 ft upgradient of the biobarrier, was also sampled during the course of the demonstration as a second background well. The total depth of each well was ~ 8 to 12 ft. bgs. An impermeable lean clay was generally encountered below these depths, and that clay served as the bottom of the treatment plot wells. Each of the oil injection and monitoring wells was screened over a 5 ft interval and just into the lean clay layer (e.g., 5 to 10 ft bgs for a well where the clay was encountered at ~ 10 ft) within the saturated zone.

A 4% (v:v) solution of emulsified oil was dissolved in site groundwater (primarily from well CMOBODO2) and amended with 0.75% (v:v) of a magnesium hydroxide colloidal solid (CoBupH) to increase and buffer pH. A total of 1380 gal of the emulsified oil/buffer solution was injected. Each well received an average of 69 (\pm 25) gal of the injection solution, with the total volume varying from 14 to 120 gal. Once injections were complete at each well, a small volume of unamended chase water (3 to 5 gal of the same groundwater used in the injection solution) was added to the well to clear the injection solution from the well, and push the amendments further into the formation. The variation in injection volume per well reflected the flow rate and pressure observed at each well during the injection, which in turn, was consistent with geologic heterogeneity observed at the site. Because of the geology of the test plot area, which included significant clay layers between more permeable zones, the average flow rate to the wells was generally maintained between 0.1 and 0.5 gallons per minute (GPM). The emulsified oil injection in all 20 IWs was completed over a period of 3.5 days, and caused no disruption to range activities, as the site was on standby for quarterly groundwater sampling. This time could easily be reduced at sites where the local aquifer is more conductive, and faster pumping rates could be achieved.

Some decrease in contaminant removal was noted the first year after biobarrier installation. It is likely that the yearly fluctuation in the groundwater elevation resulted in higher than expected usage of emulsified oil in the shallow aquifer, as saturated areas were dewatered (and likely exposed to oxygen) during some times of the year. Therefore, a second oil injection was performed after 20 months when there were indications that contaminant removal effectiveness was reduced downgradient of the biobarrier. For this injection, a solution containing 9.5% (v:v) emulsified oil solution and 0.75% (v:v) CoBupH was added. The injectate was introduced primarily into a subset of the seven centermost barrier wells. A total of 585 gal of the emulsified oil/buffer solution was injected. The total volume injected into each of the wells varied from 15 to 130 gal. A small volume (2.5 to 17 gal) of clean chase water was again injected into each well after the emulsified oil/buffer solution. The second injection lead to rapid and extensive loss of RDX, HMX, and perchlorate up to 40 feet downgradient from the barrier.

The groundwater in the aquifer was acidic before the demonstration, with an average pH within the test plot of 4.6 ± 0.4 S.U. Groundwater in upgradient monitoring MW-10, which was not impacted by the emulsified oil and buffer injection, remained acidic during the demonstration period, with an average pH of 4.6 ± 0.2 S.U. The pH along the centerline of the demonstration plot (from within the biobarrier to 40 ft downgradient of the barrier) generally increased upon injection of the buffering agent along with the emulsified oil, as did the majority of the rest of the plot area. The in-barrier wells maintained a neutral pH value of 7.1 ± 1.2 S.U., while the centerline wells remained approximately one unit above the in situ pH for the duration of the demonstration (5.6 ± 0.7 S.U). Thus, the buffer addition was very effective at increasing groundwater pH and maintaining that elevated pH throughout the demonstration period.

No organic explosives other than RDX (and RDX breakdown products) and HMX were detected in the groundwater above the method detection limit ($0.03 \mu\text{g/L}$). The concentration of RDX in the groundwater before the demonstration averaged $104 \pm 29 \mu\text{g/L}$, and concentrations in the upgradient well remained in the same range for the duration of the study ($105 \pm 26 \mu\text{g/L}$). Concentrations of the RDX nitroso-breakdown products MNX, DNX and TNX were $<0.5 \mu\text{g/L}$ both before the emulsified oil injection and in the upgradient well for the duration of the demonstration.

Upon emulsified oil injection, RDX concentrations decreased significantly downgradient of the biobarrier, with a degradation “front” slowly moving down the centerline of the plot. The RDX removal averaged $83 \pm 17\%$ for the in-barrier wells and $75 \pm 21\%$ for the centerline wells from the first emulsified oil injection to the end of the demonstration. However, these averages included periods of time when the TOC from the emulsified oil injection(s) was depleted leading to increased RDX in downgradient wells. When total organic carbon (TOC) from emulsified oil or its degradation products was adequate, and time was allowed for degradation to occur, RDX concentrations reached extremely low levels in the centerline wells. For example, approximately 8 months after the initial oil injection, the RDX within the barrier to a distance of 30 ft downgradient ranged from <0.03 to $6 \mu\text{g/L}$. RDX removal in these wells was $>94\%$. Similarly, 10 months after the second emulsified oil injection, RDX concentrations along the centerline wells ranged from $<0.03 \mu\text{g/L}$ (5/7 wells) to $2 \mu\text{g/L}$ (2 wells) as far as 40 ft downgradient of the barrier, with removal percentages $>98\%$ over this large distance. Thus, this technology was highly effective for promoting RDX biodegradation when adequate TOC and appropriate biogeochemical conditions were achieved.

The RDX metabolites MNX, DNX, and TNX increased as RDX degraded in response to the initial and secondary emulsified oil injections, and conversely decreased as RDX degradation slowed. The trends indicate that the nitroso metabolites were being produced in measurable, albeit not stoichiometric concentrations, but were also being further transformed, degraded, or otherwise attenuated, and were therefore not expected to be present at any appreciable concentration further downgradient. To that end, during the final sampling event of the demonstration, approximately 30 months after the initial oil injection, MNX, DNX and TNX were below detection ($<0.08 \mu\text{g/L}$) in 11 of the combined in-barrier and downgradient wells, and were present at a maximum of $1.1 \mu\text{g/L}$ in the remaining 4 wells that had detectable intermediates. These data suggest that the RDX

ring structure was being broken during biodegradation, leading to non-toxic and/or otherwise labile products.

The concentration of HMX in the groundwater before the demonstration averaged 15 ± 5 $\mu\text{g/L}$, and concentrations in the upgradient well remained in the same range for the duration of the study (17 ± 3 $\mu\text{g/L}$). As with RDX, HMX concentrations decreased significantly downgradient of the biobarrier after emulsified oil injection, with a degradation “front” slowly moving down the centerline of the plot. HMX removal was slightly lower than RDX removal, averaging $77 \pm 20\%$ for the in-barrier wells and $61 \pm 32\%$ for the centerline wells from the first emulsified oil injection to the end of the demonstration. However, as noted for RDX, during periods with sufficient TOC, low HMX concentrations were achieved in the centerline wells. For example, approximately 6 months after the initial oil injection, the HMX within the barrier to a distance of 40 ft downgradient ranged from <0.03 to 4 $\mu\text{g/L}$ with an average of 1.2 $\mu\text{g/L}$. Similarly, 10 months after the second emulsified oil injection, HMX concentrations along the centerline wells ranged from <0.03 $\mu\text{g/L}$ (6/7 wells) to 2 $\mu\text{g/L}$ (1 well) as far as 40 ft downgradient of the barrier. Similar to RDX, the data suggest that this technology was also highly effective for HMX removal when appropriate biogeochemical conditions were achieved.

The concentration of perchlorate in the groundwater before the demonstration averaged 36 ± 11 $\mu\text{g/L}$, and concentrations in the upgradient well remained in the same range for the duration of the study (34 ± 5 $\mu\text{g/L}$). Perchlorate removal was greater than both RDX and HMX, with $91 \pm 9\%$ removal in the barrier wells, and was comparable to total RDX removal along the centerline at $76 \pm 21\%$ from the first emulsified oil injection to the end of the demonstration. During periods with sufficient TOC, low perchlorate concentrations were achieved in the centerline wells. For example, 6 months after the initial oil injection, the perchlorate within the barrier to a distance of 40 ft downgradient ranged from <0.5 (4 wells) to 17.2 $\mu\text{g/L}$ (1 well) with an average of 3.2 $\mu\text{g/L}$. Similarly, 10 months after the second emulsified oil injection, perchlorate concentrations along the centerline wells ranged from <0.5 $\mu\text{g/L}$ (5/7 wells) to 2.2 $\mu\text{g/L}$ (1 well) as far as 40 ft downgradient of the barrier, with an average concentration of 0.9 $\mu\text{g/L}$, an overall reduction of $>97\%$.

During in situ application of emulsified oils and other substrates, it is typical to mobilize metals, such as Fe, Mn, and sometimes As, if these are present in the existing mineral phases. During the demonstration, reasonably high concentrations of dissolved Fe were observed in some of the monitoring wells after emulsified oil and buffer injection. For example, Fe was detected at 22 mg/L in MW-1 after the first injection with 4% EOS-LS and as high as 147 mg/L after the second injection with 9% EOS-LS. The higher dissolved Fe after the second injection compared to the first likely reflects the higher oil concentration applied. After the first injection, dissolved Fe never exceeded 1 mg/L 40 ft downgradient of the biobarrier, showing that the Fe re-precipitated quickly. Increased in dissolved As and Mn concentrations were not as high as observed for Fe, with As reaching a maximum of 40 $\mu\text{g/L}$ after the first injection, and quickly declining over time. As reached a maximum of 90 $\mu\text{g/L}$ after the second higher-dose injection. Similarly, dissolved Mn did not exceed 350 $\mu\text{g/L}$ in groundwater after first oil injection, and did not exceed 700 $\mu\text{g/L}$ after the second injection. As TOC declined in the test plot after the initial oil injection, declines in Fe, Mn, and As were observed over time and over distance downgradient of the biobarrier. These

metals typically re-oxidize and precipitate as groundwater becomes increasingly aerobic and should not cause a significant issue in a range environment.

This field trial at Dahlgren NSWC suggests that an emulsified oil biobarrier is a viable alternative to reduce the migration of co-mingled perchlorate and explosives in groundwater at this and similar range sites. The optimal areas for application of this technology include open burn/open detonation (OB/OD) sites, munitions test ranges, explosive ordnance disposal (EOD) training areas, target areas, munitions disposal sites, and other regions where high concentrations of munitions constituents are likely to occur. Despite heterogeneous subsurface lithology, low pH, and low hydraulic conductivity in the aquifer at Dahlgren NSWC, emulsified oil and buffer were well distributed to form a subsurface biobarrier. RDX, HMX, and perchlorate were reduced by $\geq 92\%$ in the centerline of monitoring wells extending 40 ft downgradient of the biobarrier after the second injection of emulsified oil, and accumulation of nitroso- degradation products from RDX was minimal. Moreover, the biobarrier required no operation and maintenance (O&M) other than injection and reinjection of oil substrate, and resulted in no impacts to ongoing range activities.

1.0. INTRODUCTION

1.1 BACKGROUND

Perchlorate (ClO_4^-) and explosives, particularly hexahydro-1,3,5-trinitro-1,3,5-triazine (RDX), are widespread soil contaminants at former and current military facilities, including many operational ranges. Because these compounds are readily transported through soils to the subsurface, they presently impact groundwater and drinking water at numerous military facilities across the country. One important objective for sustaining an operational range is to prevent off-site contaminant migration, while allowing typical range training and testing activities to occur uninterrupted. Both organic explosives like RDX and perchlorate have been shown individually to be amenable to biological degradation under anoxic conditions (Hatzinger, 2005; Hawari *et al.*, 2000). However, there is little overall information on the potential for the joint treatment of these compounds either biologically or through abiotic approaches.

1.2 OBJECTIVE OF THE DEMONSTRATION

During this ESTCP demonstration, we installed a passive subsurface biobarrier to treat dissolved explosives and perchlorate in groundwater at an operational military range. The optimal areas for application of this technology include open burn/open detonation (OB/OD) sites, munitions test ranges, explosive ordnance disposal (EOD) training areas, target areas, munitions disposal sites, and other regions where high concentrations of munitions constituents are likely to occur. The Churchill Range in the Explosives Experimental Area (EEA) of the Naval Surface Warfare Center, Dahlgren in Dahlgren, VA (NSWC Dahlgren) was chosen as the demonstration site for this ESTCP project. The barrier, which was placed downgradient of a location where testing activities occur at NSWC, Dahlgren, consisted of an emulsified oil substrate and buffer applied to the subsurface. This barrier promoted the rapid in situ biodegradation of perchlorate and explosives, including RDX and HMX. Important to the mission of operational DoD ranges, the barrier had no surface structure (e.g., pumping wells, control building) and no significant impact on typical range activities. A key objective of this demonstration was to apply an effective long-term solution of contaminant migration in groundwater with minimal impact to range activities.

1.3 REGULATORY DRIVERS

There are currently no federal drinking water standards (maximum contaminant level [MCL]) for the energetics that are the object of this demonstration. However, the U.S. Environmental Protection Agency (USEPA) has listed both RDX and perchlorate on the Draft Drinking Water Candidate Contaminant List (<http://water.epa.gov/scitech/drinkingwater/dws/ccl/ccl3.cfm>) and the Unregulated Contaminant Monitoring Regulation List (<http://water.epa.gov/lawsregs/rulesregs/sdwa/ucmr/factsheet.cfm>). In addition, the USEPA has issued lifetime Health Advisory Limits (Maximum Contaminant Goal Levels; MCGL) of 2 $\mu\text{g/L}$ for RDX and 400 $\mu\text{g/L}$ for HMX (USEPA, 2004), and recently announced that a Federal MCL will be established for perchlorate under the Safe Drinking Water Act (http://water.epa.gov/drink/contaminants/unregulated/upload/FactSheet_PerchlorateDetermination.pdf). The states of Massachusetts and California currently have drinking water MCL values for perchlorate of 1 $\mu\text{g/L}$ and 6 $\mu\text{g/L}$, respectively.

The State of Virginia has issued Groundwater Protection Standards for RDX, HMX, perchlorate, TNT, and a variety of TNT degradation intermediates. The specific criteria for compounds detected on the Churchill Range at NSWC Dahlgren are 1.08 µg/L for RDX, 1800 µg/L for HMX and 70 µg/L for perchlorate (**Table 1.1**). Several DoD sites have already come under regulatory pressure to stop activities that may result in contamination of groundwater with these compounds, as well as to begin remediating contaminated groundwater and overlying soil. This technology is designed to help the DoD meet these challenges while continuing to operate the ranges to maintain military preparedness.

Table 1.1. Virginia Groundwater Protection Standards.

Constituents	GPS (µg/L)	Source
Energetics		
1,3,5-trinitrobenzene	469.5	2
1,3-dinitrobenzene	3.7	3
2,4,6-trinitrotoluene	2.2	3
2,4-dinitrotoluene	31.3	2
2,6-dinitrotoluene	15.65	2
2-amino-4,6-dinitrotoluene	73	3
2-nitrotoluene	0.046	3
3-nitrotoluene	120	3
4-amino-2,6-dinitrotoluene	73	3
4-nitrotoluene	0.62	3
Ethylene glycol dinitrate	NA	
HMX	1800	3
Nitrobenzene	1.3	2
Nitroglycerin	4.8	3
PETN	NA	
RDX	1.08	5
Tetryl	150	3
Semi-volatiles		
1,1-biphenyl	300	3
2,2'-oxybis(1-chloropropane)	NA	
2,4,5-trichlorophenol	1565	2
2,4,6-trichlorophenol	6.09	2
2,4-dichlorophenol	46.95	2
2,4-dimethylphenol	313	2
2,4-dinitrophenol	31.3	2
2-chloronaphthalene	178.86	2
2-chlorophenol	11.18	2
2-methylnaphthalene	44.71	2

Constituents	GPS ($\mu\text{g/L}$)	Source
2-methylphenol	782.5	2
2-nitroaniline	110	3
2-nitrophenol	NA	
3-3'-dichlorobenzidine	0.1488	2
3-nitroaniline	0.127	2
4,6-dinitro-2-methylphenol	1.565	2
4-bromophenyl phenyl ether	NA	
4-chloro-3-methylphenol	NA	
4-chloroaniline	62.6	2
4-chlorophenyl phenyl ether	NA	
4-methylphenol	78.25	2
4-nitroaniline	3.3	3
4-nitrophenol	125.2	2
Acenaphthene	134.14	2
Acenaphthylene	NA	
Acetophenone	0.01487	2
Anthracene	670.7	2
Atrazine	30	3
Benzaldehyde	3700	3
Benzo(a)anthracene	0.09	2
Benzo(a)pyrene	0.2	1
Benzo(b)fluoranthene	0.09	2
Benzo(g,h,i)perylene	NA	
Benzo(k)fluoranthene	0.09	2
Bis(2-chloroethoxy)methane	NA	
Bis(2-chloroethyl)ether	9.59×10^{-3}	2
Bis(2-ethylhexyl)phthalate	10.0	5
Butyl benzyl phthalate	100	1
Caprolactam	1.8×10^4	3
Carbazole	3.3	3
Chrysene	0.2	1
Dibenzo(a,h)anthracene	0.3	1
Dibenzofuran	8.9	2
Diethyl phthalate	12520	2
Dimethyl phthalate	156500	2
Di-n-butyl phthalate	13.7	5
Di-n-octyl phthalate	313	2
Fluoranthene	626	2
Fluorene	89.43	2
Hexachlorobenzene	1.0	1

Constituents	GPS (µg/L)	Source
Hexachlorobutadiene	0.8586	2
Hexachlorocyclopentadiene	50	1
Hexachloroethane	4.78	2
Indeno(1,2,3-cd)pyrene	0.4	1
Isophorone	70.50	2
Naphthalene	2.33	2
Nitrobenzene	1.30	2
N-nitrosodi-n-propylamine	9.57 x 10 ⁻³	2
N-nitrosodiphenylamine	13.67	2
Pentachlorophenol	1.0	1
Phenanthrene	NA	
Phenol	9390	2
Pyrene	67.07	2
Metals (Total)		
Antimony	6	1
Arsenic	10	1
Barium	2000	1
Beryllium	4	1
Cadmium	5	1
Chromium	100	1
Cobalt	313	2
Copper	1300	1
Lead	15	1
Mercury	2	1
Nickel	313	2
Selenium	50	1
Silver	78.25	2
Thallium	2	1
Vanadium	109.55	2
Zinc	4695	2
Miscellaneous		
Benzene		
Phenols (total)		
Sulfide		
Nitrate/nitrite	10 mg/L	1
Cyanide	200	1
Perchlorate	70	5

Groundwater protection standard concentration limits are based on:

1. Maximum Contaminant Levels (MCLs derived from EPA's *Drinking Water Regulations and Health Advisories*).

2. Alternate Concentration Limits (ACLs derived from REAMS)
3. EPA Region III RBC Table, Tap water (April 7, 2005)
4. NA = none available
5. Facility background

2.0. TECHNOLOGY

2.1 TECHNOLOGY DESCRIPTION

Techniques to remove explosives from surface soils, including soil washing, composting, soil bioreactors, iron amendment, and enhanced in situ soil treatment, are well established (Comfort *et al.*, 2003; Fuller *et al.*, 2003; Griest *et al.*, 1993; Zhang *et al.*, 2001), but there are presently few proven methods to treat energetic compounds in groundwater. In addition, although in situ bioremediation technologies for perchlorate in water have been developed and implemented (Hatzinger, 2005; Stroo and Ward, 2008), there is little relevant field information concerning joint treatment of perchlorate and nitramine explosives in groundwater (Fuller *et al.*, 2007; Schaefer *et al.*, 2007; Weeks *et al.*, 2003). During this demonstration, we tested and validated a passive remedial approach for treating co-mingled perchlorate and RDX in groundwater at an operational DoD range. This test was specifically designed to minimize impact on range activities, while determining the potential for long-term protection of downgradient groundwater.

Previous studies conducted in our laboratory with samples from Indian Head, MD revealed that perchlorate and nitramine explosives (RDX and HMX) can be treated together in groundwater using select organic substrates, including emulsified oil substrate (**Figure 2.1**; Schaefer *et al.*, 2007). Other approaches, such as application of various forms of zero-valent iron (ZVI) and nickel catalysts also were effective for the nitramines, but not for perchlorate. More recently, microcosms prepared with aquifer samples from the EEA at NSWC, Dahlgren revealed that degradation of both RDX and perchlorate at this location can be stimulated via the addition of emulsified oil, as well as other substrates, including ethanol and glucose (**Figure 2.2**). These data were gained through SERDP Project ER-1607 “New Approaches to Evaluate the Biological Degradation of RDX in Groundwater” in which our research group (including CB&I, Texas A&M, Biotechnology Research Institute, NRC, Canada, and University of Illinois at Chicago) evaluated techniques to better understand in situ RDX biodegradation (<https://www.serdp-estcp.org/Program-Areas/Environmental-Restoration/Contaminants-on-Ranges/Characterizing-Fate-and-Transport/ER-1607/ER-1607>). One of the techniques developed/evaluated during this SERDP project, stable isotope probing (SIP), was applied to site samples from Dahlgren in conjunction with this ESTCP project to better understand the microbial community responsible for RDX degradation in the aquifer under different electron-accepting conditions.

Emulsified oil substrates consist of small, stable oil droplets that are completely miscible in water (Borden *et al.*, 2008a). When injected into the subsurface, these oil droplets move into the aquifer and slowly adsorb to solid particles, resulting in a thin coating of oil on aquifer solids in the barrier area (**Figure 2.3**). A volume of chase water is usually added after the emulsified oil injection to adequately disperse the solution into a continuous barrier. The spacing of injection points and volume of emulsified oil required to form a barrier, as well as barrier longevity, depend on the existing hydrological and geochemical conditions. A recently published emulsified oil design tool, which resulted from an ESTCP project, provides guidance concerning barrier installation (Borden *et al.*, 2008b). This tool was used to aid in the design of the biobarrier. Once the barrier is installed, the emulsified oil provides a long-term source of organic carbon and electron donors to support reductive degradation of contaminants. The primary application of this technology to date being for chlorinated ethenes, and in one DoD demonstration, perchlorate and 1,1,1-trichloroethane (Borden, 2007).

During this demonstration, emulsified oil substrate was injected into the subsurface to form a passive biobarrier. The oil substrate promotes the growth of indigenous bacteria capable of biodegrading perchlorate and RDX to low concentrations (RDX <0.25 µg/L and perchlorate <1 µg/L based on our laboratory data). To our knowledge, emulsified oil barriers have not been evaluated and validated in the field for enhancing biodegradation of explosives or for mixed explosives and perchlorate. The technology has also not been applied and verified at the field-scale to address groundwater contamination on an active range, although this approach appears well suited for preventing offsite migration of pollutants from some range activities, such as OB/OD.

The effectiveness of the barrier for reducing migration of perchlorate and explosives in groundwater at the EEA of NSWC, Dahlgren was determined using a series of groundwater monitoring wells. The details of the demonstration are provided in Section 4. A graphic showing the basic field layout design is provided in **Figure 2.4**. The biobarrier was installed cross-gradient to groundwater flow. Upgradient and downgradient groundwater were monitored for perchlorate, RDX, HMX and their nitroso- degradation intermediates, field parameters, total organic carbon (TOC; as a measure of oil concentration), fatty acids, dissolved metals, anions, and field parameters for a period of approximately 30 months after the initial emulsified oil injection. Depending on hydrological and geochemical characteristics, emulsified oil barriers can effectively provide reducing conditions for more than 5 years (ESTCP, 2006).

Studies were also undertaken to identify the specific bacterial communities in the Dahlgren aquifer biodegrading RDX through advanced molecular analysis with stable isotope probing (SIP; (Roh *et al.*, 2009)). The application of this method provides valuable information on the identity of key microorganisms responsible for degrading RDX in the aquifer under different electron-accepting conditions, and the portion of the molecule that they utilize (e.g., ring-N, nitro-N and/or ring-C).

In summary, this project demonstrates and verifies a passive remedial approach for treating RDX and perchlorate in groundwater at an operational DoD range. During the project, an advanced molecular technique was utilized to assess the organisms responsible for in situ energetics biodegradation. Most critically, the project was designed to show that groundwater treatment and protection can be implemented on an operational range without significantly affecting mission-critical range activities.

Figure 2.1. Combined treatment of perchlorate, RDX, and HMX in flow-through columns containing aquifer solids from a US Navy site.

Column effluent data are presented in panel (A). The columns (shown in panel B) were treated with emulsified oil as a slow-release carbon source, and groundwater was passed through the columns with a 1 day HRT (1ft/day groundwater flow). No degradation was observed in columns without oil (data not shown). A mathematical model was developed to describe contaminant degradation, and relevant model fits are provided (Figure modified from Schaefer et al., 2007).

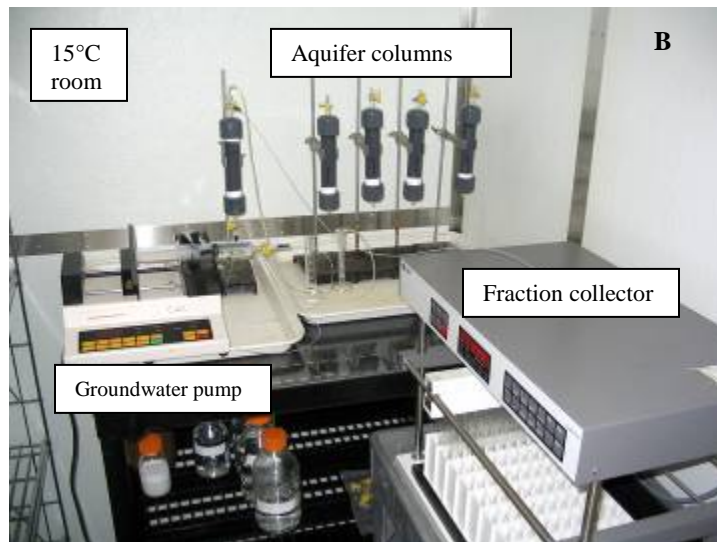
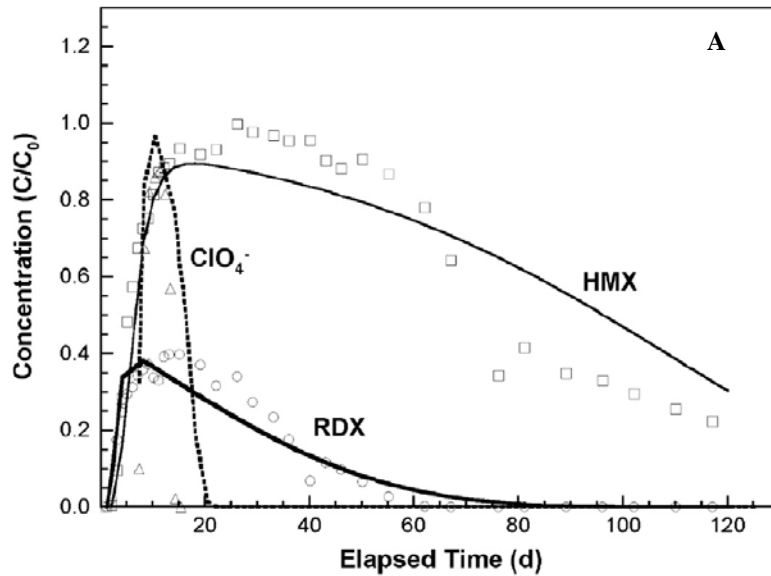
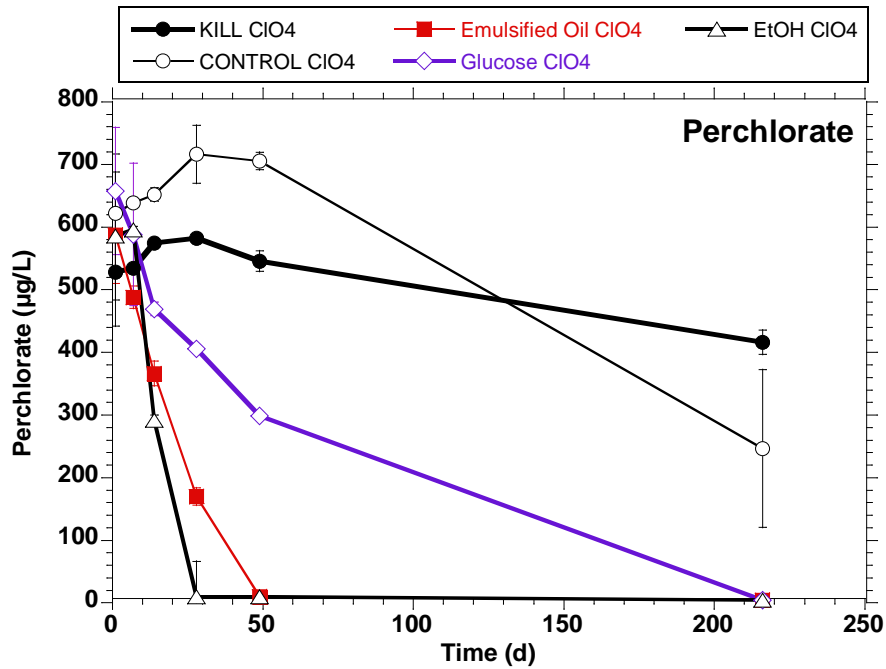

Figure 2.2. Biological degradation of perchlorate (A) and RDX (B) in microcosms.

Microcosms were prepared from aquifer solids and groundwater from the Explosives Experimental Area at NSWC Dahlgren, Dahlgren, VA. Microcosms (160-mL serum bottles) received glucose or ethanol at 1 mg/L or emulsified oil at 1 mg/L as TOC. All bottles were incubated under anoxic conditions at 15°C

(A)



(B)

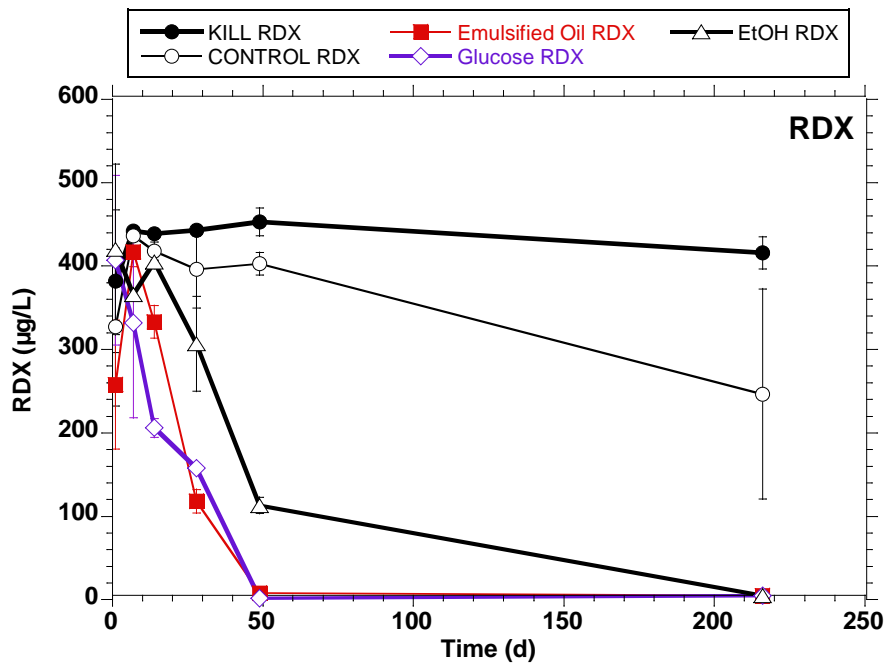

Figure 2.3. Disposition of emulsified oil after injection into groundwater as a function of time.

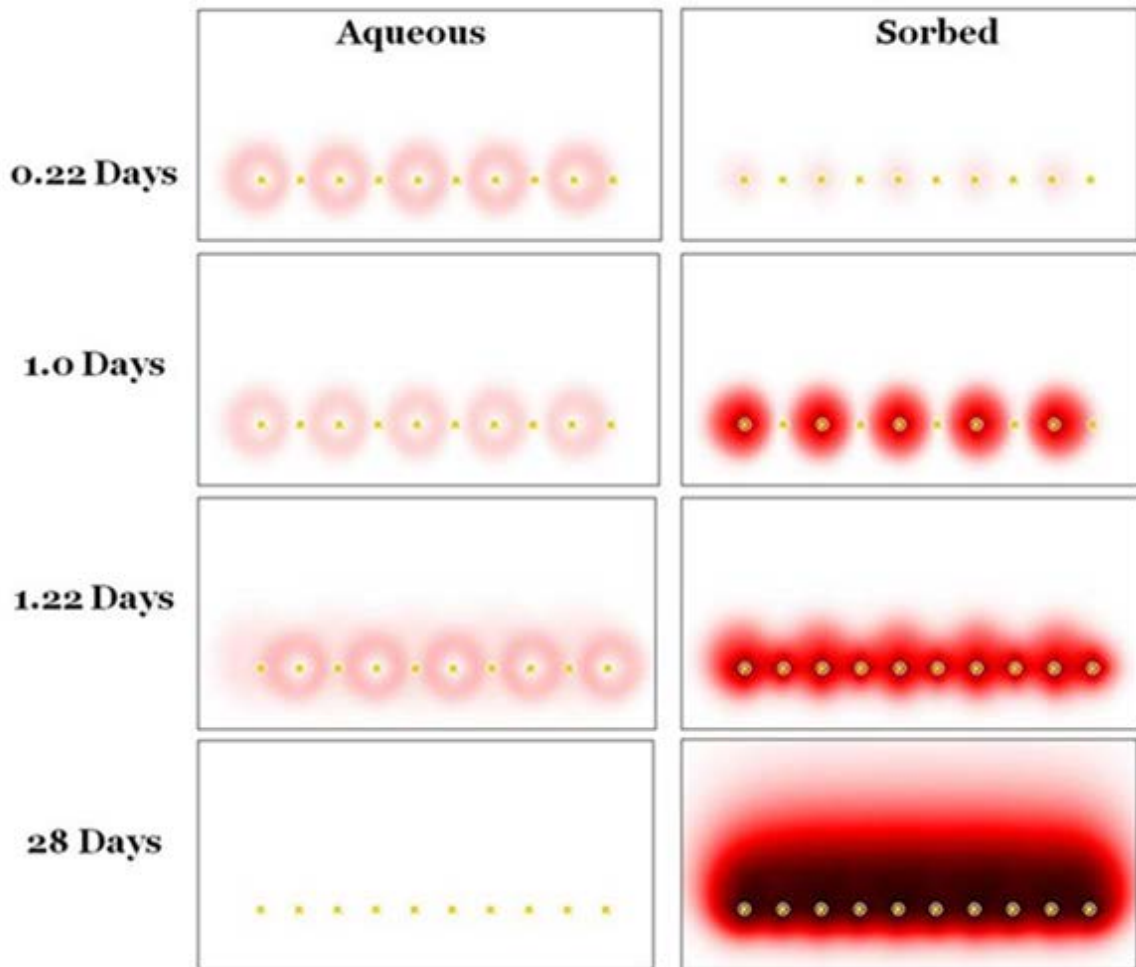
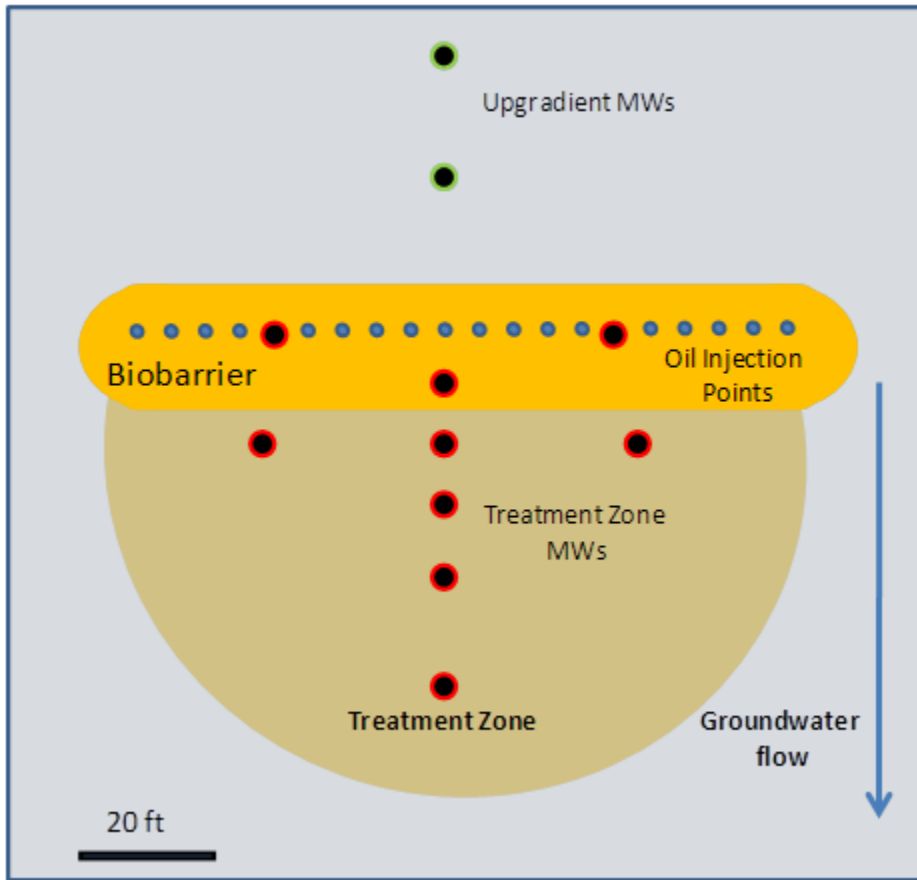

Figure 2.4. Schematic of generalized biobarrier design and monitoring well network.
The actual design was based on specific site conditions.



2.2 ADVANTAGES AND LIMITATIONS OF THE TECHNOLOGY

2.2.1 Advantages

The main advantages of utilizing an in situ approach for explosives and perchlorate treatment are as follows:

1. Appreciably reduced cost and infrastructure compared to traditional pump-and-treat approaches.
2. Complete destruction of explosives and perchlorate rather than transfer to a secondary medium, such as granular activated carbon.

In addition, the use of a passive design in which emulsified oil is applied to the subsurface is advantageous in several ways:

1. There is no requirement for pumping wells or aboveground infrastructure typical for active pumping designs. Such infrastructure is impractical in a range environment.
2. Minimal engineering design is required compared to an active in situ system.
3. There are significantly reduced system O&M requirements and costs, including electrical and biofouling control costs.
4. Long-term effectiveness of the biobarrier is expected depending on groundwater geochemistry and hydrology (>5 years possible).

2.2.2 Limitations

As with all technologies, there are also limitations with passive treatment approaches;

1. Technology becomes expensive to implement in deep aquifers (>50 ft) due to the costs of injecting the substrate at depth.
2. The groundwater oxidation-reduction potential (ORP) will be significantly reduced, which is necessary to create conditions conducive to treatment explosives and perchlorate, but also causes secondary geochemical impacts, such as mobilization of metals (e.g., dissolved Fe [II] and Mn [III] from dissolution of Fe and Mn oxides), sulfide production, and other changes in groundwater geochemistry that impact local groundwater quality.
3. Absence of hydraulic control, which can be gained with pumping wells in an active in situ system. One must rely on the natural gradient to move contaminant through the barrier.
4. Necessity for closely spaced injections of emulsified oil in tight formations.

Additional details on the advantages and limitations of passive approaches for substrate addition compared to semi-passive and active approaches can be found in Stroo and Ward (2009), which evaluates options for in situ perchlorate treatment.

3.0. PERFORMANCE OBJECTIVES

Performance objectives are summarized in **Table 3.1**, and detailed descriptions of objectives are provided in **Sections 3.1** through **3.5**.

Table 3.1. Performance objectives.

Performance Objective	Data Requirements	Success Criteria	Results
Quantitative Performance Objectives			
Effectiveness of RDX treatment	Pre- and post-treatment contaminant concentrations in groundwater wells using EPA Method 8330.	<ul style="list-style-type: none"> • Reduction in downgradient groundwater in one or more monitoring well(s) to <1.08 µg/L • Overall downgradient RDX reduction >95% • Statistical comparison: <ul style="list-style-type: none"> - Pre- and post-barrier installation - Upgradient vs. downgradient monitoring wells 	
Effectiveness of perchlorate treatment	Pre- and post-treatment contaminant concentrations in groundwater wells using EPA Method 314.0.	<ul style="list-style-type: none"> • Reduction in one or more downgradient monitoring wells to <2 µg/L • Overall downgradient perchlorate reduction >95% • Statistical comparison: <ul style="list-style-type: none"> - Pre- and post-barrier installation - Upgradient vs. downgradient monitoring wells 	
Distribution of emulsified oil	Measurement of TOC	TOC elevated in monitoring wells 2.5 ft and 5 ft downgradient	
Geochemical changes to create conditions necessary for contaminant degradation	Measurements of DO Measurements of ORP	DO <1 mg/L in all treatment wells ORP below -100 mV in all treatment wells	

Longevity of biobarrier	TOC and treatment efficacy over time	Barrier effective 2 years after installation	
Qualitative Performance Objectives			
Barrier Installation	Total time for installation Feedback from field technician	<5 days for barrier installation	
	Maintenance logs & time	Minimal maintenance costs	

3.1 EFFECTIVENESS OF RDX AND PERCHLORATE TREATMENT

The effectiveness of the biobarrier technology for groundwater remediation was a function of the degree to which RDX and perchlorate concentrations decreased. Remediation success depended on the residual contamination during and after application of the treatment remedy. The overall duration of the biobarrier performance was also of interest during this project and was quantified via extended testing.

3.1.1 Data Requirements for RDX and Perchlorate Treatment

As previously detailed in Section 2.0 and detailed further in Section 5.3, an emulsified oil biobarrier was installed at Dahlgren, cross-gradient to groundwater flow. A series of groundwater wells were installed upgradient, downgradient, and within the oil barrier. The groundwater wells were installed prior to emulsified oil injection in order to establish baseline concentrations in each well. Two rounds of baseline data were then collected prior to barrier installation. After barrier installation, groundwater samples were collected 10 times over the next 30 months. All RDX analyses were conducted by EPA Method 8330 and perchlorate analyses by EPA Method 314.0.

3.1.2 Success Criteria for RDX and Perchlorate Treatment

The success criteria were reductions in RDX and perchlorate in groundwater to <1.08 µg/L and <2 µg/L, respectively, in one or more downgradient monitoring wells. The value for RDX is the Virginia Groundwater Protection Standard (see **Table 1.1**). The value for perchlorate represents the lowest state standard in the US (2 µg/L in Massachusetts), which is more stringent than the Virginia Groundwater Protection Standard of 70 µg/L. A second standard-independent objective was an overall reduction in RDX and perchlorate concentrations of >95% in downgradient monitoring wells from the pre-treatment to the post-treatment phase. Treatment effectiveness was measured by comparing RDX and perchlorate concentrations: (1) in each of the impacted downgradient monitoring wells before and after barrier installation, and (2) in the upgradient monitoring well with those in the downgradient treatment zone during each sampling event.

3.2 ADEQUATE DISTRIBUTION OF EMULSIFIED OIL

Homogeneous oil distribution was deemed important to the success of this biobarrier approach for RDX and perchlorate treatment. The distribution of emulsified oil was quantified by measuring Total Organic Carbon (TOC) increases in the wells installed within the biobarrier. In addition,

both TOC and Volatile Fatty Acids (VFAs; breakdown products of emulsified oil) were measured in downgradient monitoring wells.

3.2.1 Data Requirements for Oil Distribution

TOC was measured at CB&I's Analytical Laboratory in Lawrenceville, NJ by SM-5310 and VFAs were measured by EPA Method 300.0m. Distribution of oil and resulting products were assessed by comparing RDX and perchlorate concentrations: (1) in each of the downgradient monitoring wells before and after barrier installation and (2) in the upgradient monitoring well with those in the downgradient treatment area during each selected sampling event.

3.2.2 Success Criteria for Oil Distribution

The success criterion for oil distribution was (1) a significant increase in TOC within the barrier monitoring and the first two downgradient wells (2.5 and 5 ft downgradient of the barrier) after emulsified oil injection; and (2) increased levels of VFAs in the downgradient wells during the initial 6 months of the demonstration.

3.3 GEOCHEMICAL CHANGES

The addition of emulsified oil as an in situ biobarrier typically creates reducing conditions due to microorganisms consuming oxygen, nitrate, and other available electron acceptors during oxidation of oil components. The reducing conditions are necessary for degradation of explosives and perchlorate.

3.3.1 Data Requirements for Geochemical Changes

The parameters measured to assess potential geochemical changes were as follows (1) dissolved oxygen (DO or dissolved O₂) by field meter; (2) oxidation-reduction potential (ORP) by field meter. In addition to these parameters, other geochemical parameters were measured including pH, anions, and dissolved Fe, Mn, and As.

3.3.2 Success Criteria for Geochemical Changes.

The success criteria for measured geochemical changes were as follows: (1) dissolved O₂ <1 mg/L in all impacted downgradient wells; (2) ORP reduced to below -100 mV in all wells throughout the demonstration.

3.4 BARRIER LONGEVITY

The proposed biobarrier for groundwater remediation was expected to remain effective for a minimum of 2 years, based on groundwater flow, electron acceptor concentrations, and other variables.

3.4.1 Data Requirements for Barrier Longevity

The biobarrier longevity was judged based upon (1) the measurement of elevated TOC in the biobarrier wells, and the wells immediately downgradient and (2) reduced concentrations of RDX and perchlorate in the wells immediately downgradient of the barrier.

3.4.2 Success Criteria for Barrier Longevity

The biobarrier longevity was considered adequate if (1) TOC remained elevated in the biobarrier wells, and the wells immediately downgradient and (2) RDX and perchlorate remained below VA

Groundwater Protection Standards in the wells immediately downgradient of the barrier for a period of 2 years after barrier installation (or for explosives and perchlorate, 2 years after the initial reductions are observed assuming some lag period after initial oil injection).

3.5 EASE OF BARRIER INSTALLATION

One key objective was to minimize downtime on the active range, so minimizing the time required for biobarrier installation and operation was critical.

3.5.1 Data Requirements for Barrier Installation & Operation

The total length of time for biobarrier installation was recorded. System reliability was evaluated qualitatively by discussions with field personnel and quantitatively by evaluating total downtime for any unplanned activities (e.g., reinjection of emulsified oil, etc.) and total costs of the unplanned activities.

3.5.2 Success Criteria for Barrier Installation & Operation

The qualitative success criteria for system installation was downtime of less than five (5) days for the facility, including installation of required monitoring wells and emulsified oil injection. Success for operation was “minimal” unplanned maintenance/repair and cost. Quantitatively, the system should require no more than 15% additional field technician time per month than planned for routine checks and assessment.

4.0. SITE DESCRIPTION

4.1 SITE SELECTION

The location for the demonstration was selected based upon facility interest and relevant site physical and geochemical characteristics. Military range facilities that were evaluated included the Explosives Experimental Area in at the Naval Surface Warfare Center, Dahlgren, VA, the Stump Neck Annex at the Naval Surface Warfare Center, Indian Head, MD, and the Naval Weapons Station, Earle in Colts Neck, NJ. Personnel at all three facilities were contacted concerning this research effort, and had interest in hosting the demonstration. Data evaluated for each candidate location included the following: (1) basic aquifer conditions (e.g., depth to groundwater, geochemistry, hydrology etc.); (2) RDX, perchlorate, and co-contaminant concentrations and plume characteristics; (3) basic infrastructure (e.g., site access, presence of wells, roads, etc.) and (4) potential for personnel or other project support (e.g., UXO support). The basic site selection criteria for the demonstration were as follows:

- (1) Active range facility;
- (2) Depth to groundwater <20 ft below ground surface (bgs);
- (3) Maximum depth of contamination in groundwater <50 ft bgs;
- (4) Presence of both RDX and perchlorate at concentrations >50 µg/L;
- (5) Groundwater pH >5.0;
- (6) Presence of some existing monitoring wells and baseline monitoring data;
- (7) Available UXO support.

Based on these considerations and criteria, the EEA at NSWC, Dahlgren was chosen for the demonstration.

4.2 SITE LOCATION AND HISTORY

NSWC, Dahlgren is located in King George County, VA along the Potomac River approximately 40 miles south of downtown Washington, DC and 28 miles east of Richmond, VA (**Figure 4.1**) (URS, 2010). NSWC Dahlgren, which was originally established in 1918 as a testing site for naval ordnance, is presently focused on research, development, test, and evaluation (RDT&E) of ordnance, integrated warfare systems, weapons and ammunition, sensors and directed energy, and force protection. Apart from testing and disposal activities associated with their RTD&E mission, NSWC Dahlgren accepts obsolete and/or waste munitions from other military facilities for treatment and serves as a center for emergency Explosives Ordnance Disposal (EOD) for the public sector. The explosives requiring disposal are thermally treated at the Open Burn (OB) or the Open Detonation (OD) units located at the Churchill Range of the Explosives Experimental Area (EEA) at NSWC, Dahlgren.

The EEA, which is commonly referred to as “Pumpkin Neck”, is one of the two main areas comprising NSWC, Dahlgren. The Upper Machodoc Creek passes through NSWC Dahlgren, cutting the facility into these two areas, the Mainside which consists of 2677 acres and the EEA which comprises 1614 acres (**Figure 4.2**) (Bell, 1996). The EEA is composed of >60% forest and marshland, with two open areas (Churchill Range and Harris Range) for munitions testing and disposal activities (**Figure 4.3**). The Churchill Range includes OB and OD areas as well as a Fast Cookoff area, and other facilities for ordnance and energetics testing, including drop test towers,

static thrust stands, and other facilities. This ESTCP demonstration will be conducted on the Churchill Range, at a location downgradient of the Fast Cookoff area where contamination with RDX and perchlorate is present. Extensive site assessment work (see Section 4.3.1) and treatability work (See Section 5.2.1) were conducted to determine the most suitable location for the biobarrier.

4.3 SITE GEOLOGY AND HYDROGEOLOGY

4.3.1 Basic Geology

The geology of the EEA was studied by the U.S. Geologic Survey in the mid-1990s (Bell, 1996), and has been the subject of additional investigative work by the URS Group Inc. (URS, 2010). The surface of the EEA varies in elevation from ~0 to 30 ft above mean sea level (amsl), and the surface topography is basically flat. The geology of the site consists of two sequences of fluvial-estuarine deposits (Pleistocene) that overlie marine deposits (Pleistocene-Eocene) of the Nanjemoy-Marlboro confining unit (**Figure 4.4**) (Bell, 1996). The surficial water bearing unit is the Columbia aquifer, which is the unit within which the demonstration will be conducted. The Columbia aquifer unconformably overlies the upper confining unit (clay with significant organic deposits) across most of the EEA and ranges from <8 ft to ~ 34 ft thick. The Columbia aquifer consists of sand, silt and clay with a pebble deposit at the bottom (on top of the underlying confining layer). The upper confining layer was observed to be absent in the central region of the OB/OD area; rather the Columbia aquifer appears to directly overlie the Nanjemoy-Marlboro confining unit in this region, which consists of glauconitic fine grained sands of the Nanjemoy formation (Bell, 1996; URS, 2010).

4.3.2 Groundwater Monitoring Wells.

A total of 15 permanent groundwater monitoring wells are present in the Churchill Range Area (**Figure 4.5**). Two of these wells were installed by USGS in 1993 as part of the overall site investigation work (EEA-S17, EEA-S18), during which time a total of 28 wells were drilled across the entire EEA (Belle, 1993). Eight (8) additional wells were installed by USGS in the Churchill Range area in 1998 (GWOBOD02-GWOBOD09), and five (5) wells were subsequently installed in 2007 by URS during site assessment studies (CMOBOD01-CMOBOD05). All of these wells are screened in the Columbia Aquifer.

Figure 4.1. Location of the Dahlgren site.



Figure 4.2. Map showing the main areas of NSWC Dahlgren.

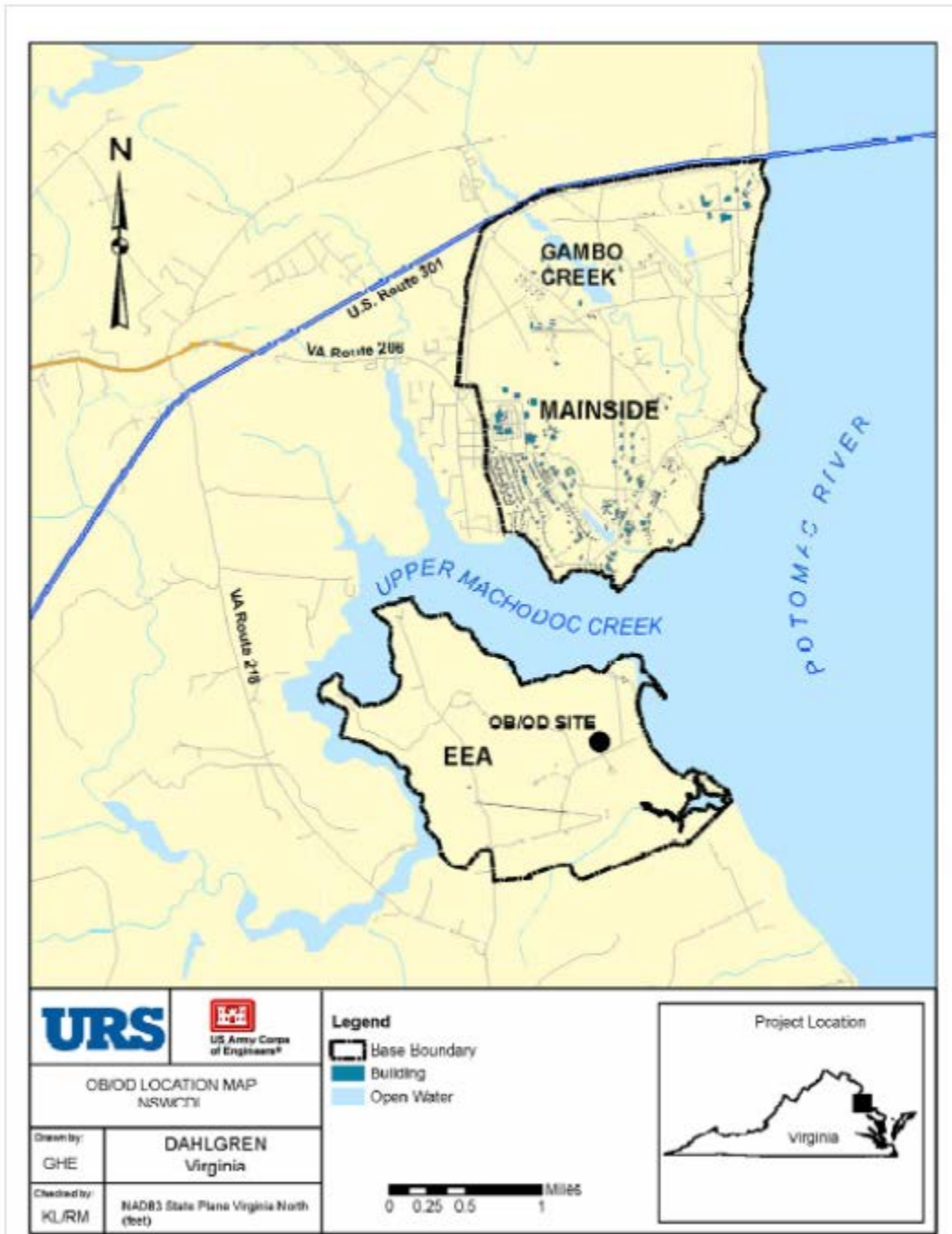

Figure 4.3. Map showing the Churchill Range of NSWC Dahlgren.
 The inset provides the location of the range within the EEA (URS, 2010).

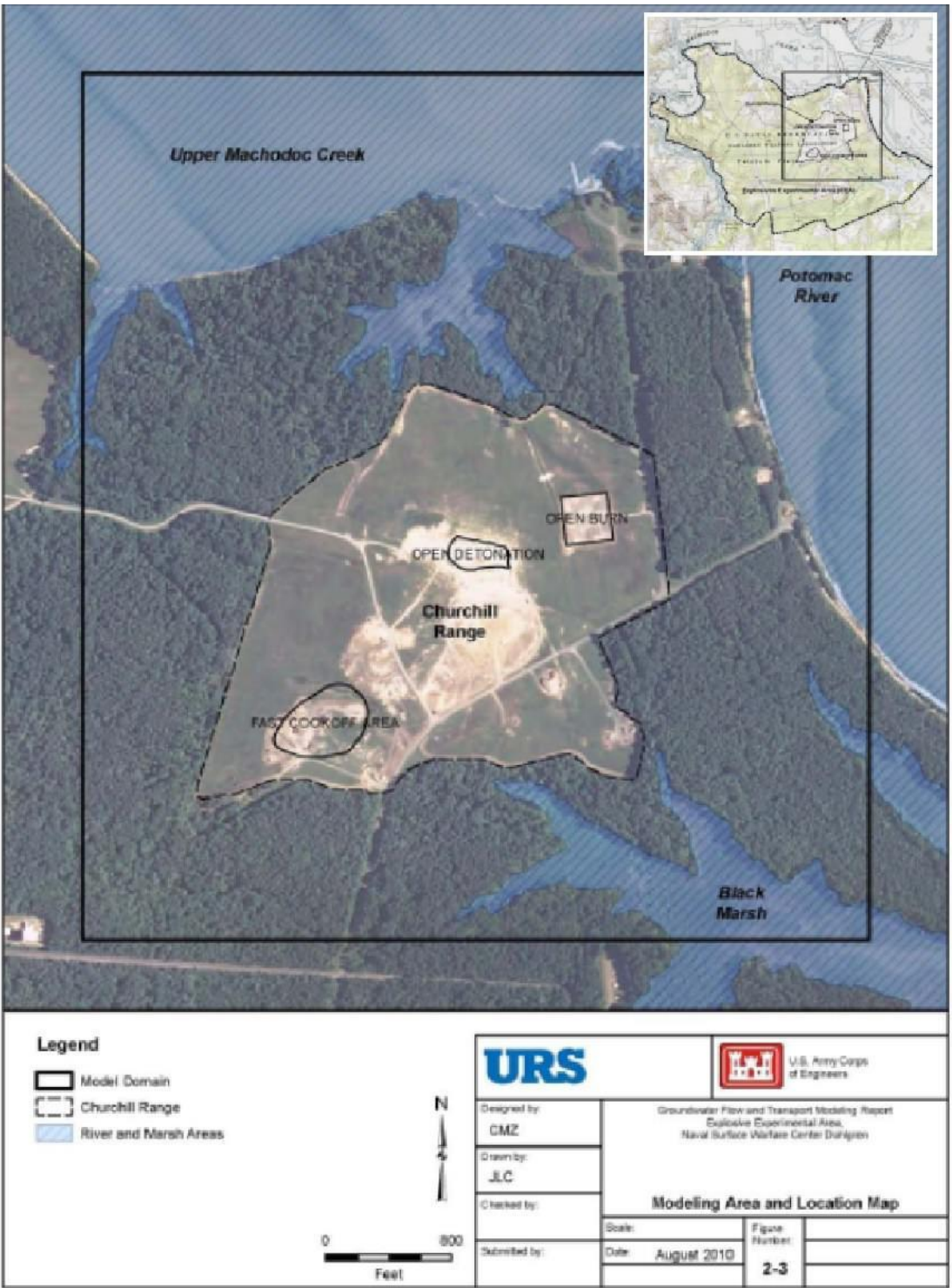
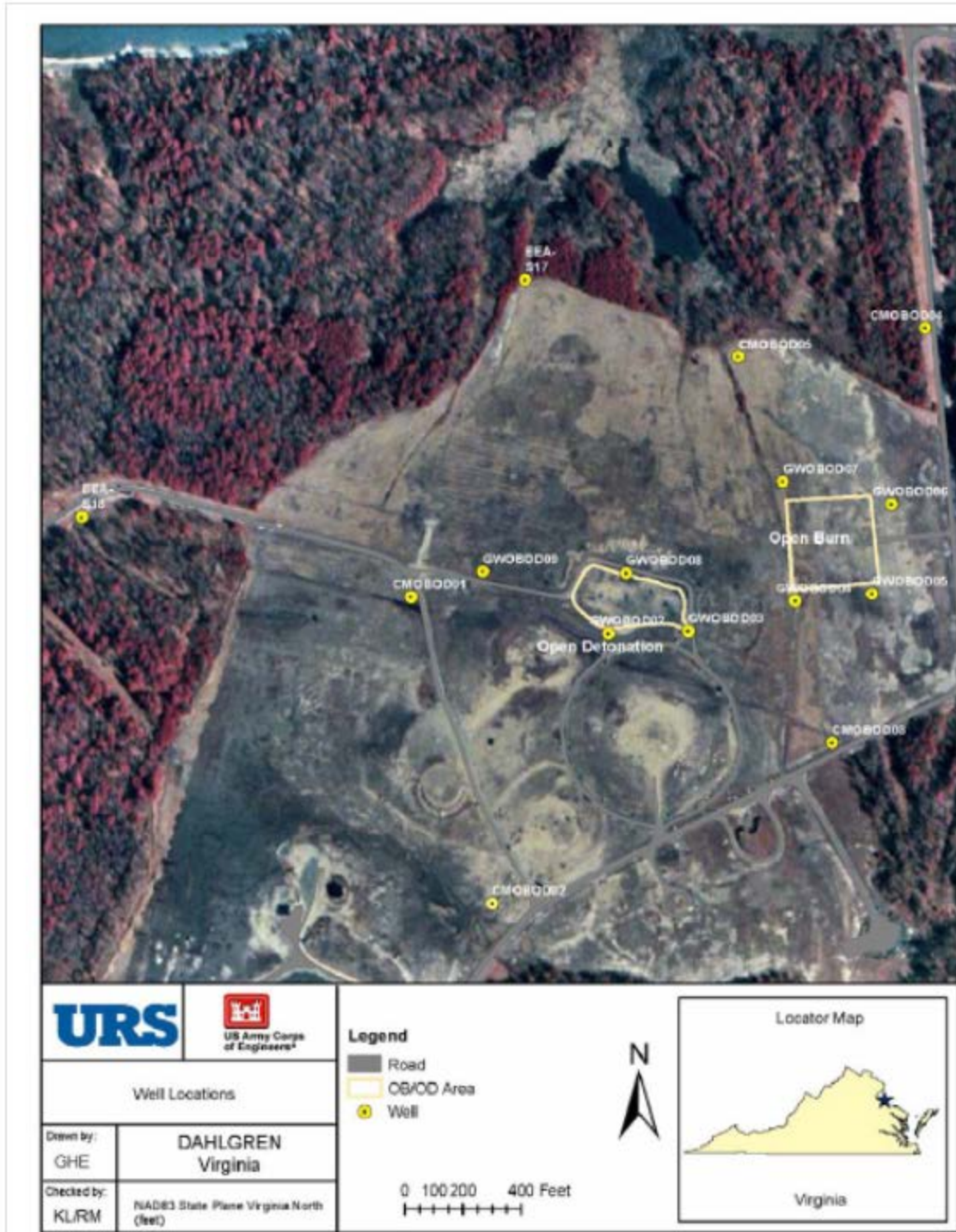

Figure 4.4. Schematic of the geologic and hydrogeologic units of the EEA.
(Bell, 1996).

		GEOLOGIC UNIT		HYDROGEOLOGIC UNIT
QUATERNARY	HOLOCENE	Alluvial, paludal, and fill deposits		Columbia aquifer
	PLEISTOCENE	Tabb Formation (Sedgefield Member)		
		Pleistocene deposits, undifferentiated		upper confining unit
				upper confined aquifer
TERTIARY	EOCENE	Nanjemoy Formation	Woodstock Member	Nanjemoy-Marlboro confining unit
			Potapaco Member	
	PALEOCENE	Marlboro Clay		

NOT TO SCALE

Figure 4.5. Map showing permanent well locations on the Churchill Range of NSWC Dahlgren.



4.3.3 Groundwater Depth

The depth to water on the range varies seasonally, but generally is from 0.1 to 8 ft below ground surface (bgs) depending on location and season, with the water table rising in the spring and declining in the summer/fall (URS, 2010). Based on 2007 data, and previous groundwater maps of the area, there is usually a groundwater divide that runs through the center of the range in an east-west direction (**Figure 4.6**). To the north of the divide, groundwater flows in a northerly direction and discharges primarily to the Upper Machodoc Creek and Potomac River, generally flowing with surface topography. The OB area on the range is near the top of the groundwater divide, with some groundwater flow going in a west-northwest direction and some southwesterly flow, depending on the location of the groundwater mound (URS, 2007). To the south of the divide, groundwater flows in a southerly direction and discharges to the Black Marsh and various tidal creeks to the south and southeast. The groundwater underlying the OD area is subject to southerly flow.

4.3.4 Groundwater Flow

Slug tests conducted by USGS in the early 1990s in 18 wells screened in the Columbia Aquifer across the entire EEA revealed hydraulic conductivities (K) ranging from 0.1 to 21 ft/day, with a median value of 1.4 ft/day (Bell, 1996). However, only two of these wells were located in the Churchill Range Area. As previously noted in Section 4.2.2, several additional wells were installed by USGS in 1998. Slug tests conducted on seven of these wells and previously-tested well EEA-S17 revealed K values ranging from 1.7 to 21 ft/day (URS, 2010), with a median value of 4.5 ft/day (**Figure 4.7**). Assuming an average aquifer porosity of 0.30, and measured horizontal hydraulic gradient of 0.002, the rates of horizontal flow across the entire EEA were determined to vary from 0.003 to 0.7 ft/day (~1 to 300 ft/year) (Bell, 1996). Using the same values for porosity and horizontal gradient, and the K values specifically from the Churchill Range wells, the horizontal flow in this area might be expected to range from 4 to 300 ft/yr.

Data suggest that there is significant variability in both groundwater flow direction and rates across the EEA and the much smaller area of the Churchill Range. The range of estimated hydraulic conductivities are shown in **Figure 4.7** (URS, 2010). These data were considered when choosing in the location of the demonstration within the Churchill Range, and a more detailed location-specific determination of groundwater flow rate and direction in the vicinity of the Fast Cookoff area was conducted (Section 5.2).

Figure 4.6. Potentiometric surface map of the Churchill Range Area in Spring, 2007.
 Figure from modified from URS, 2007.

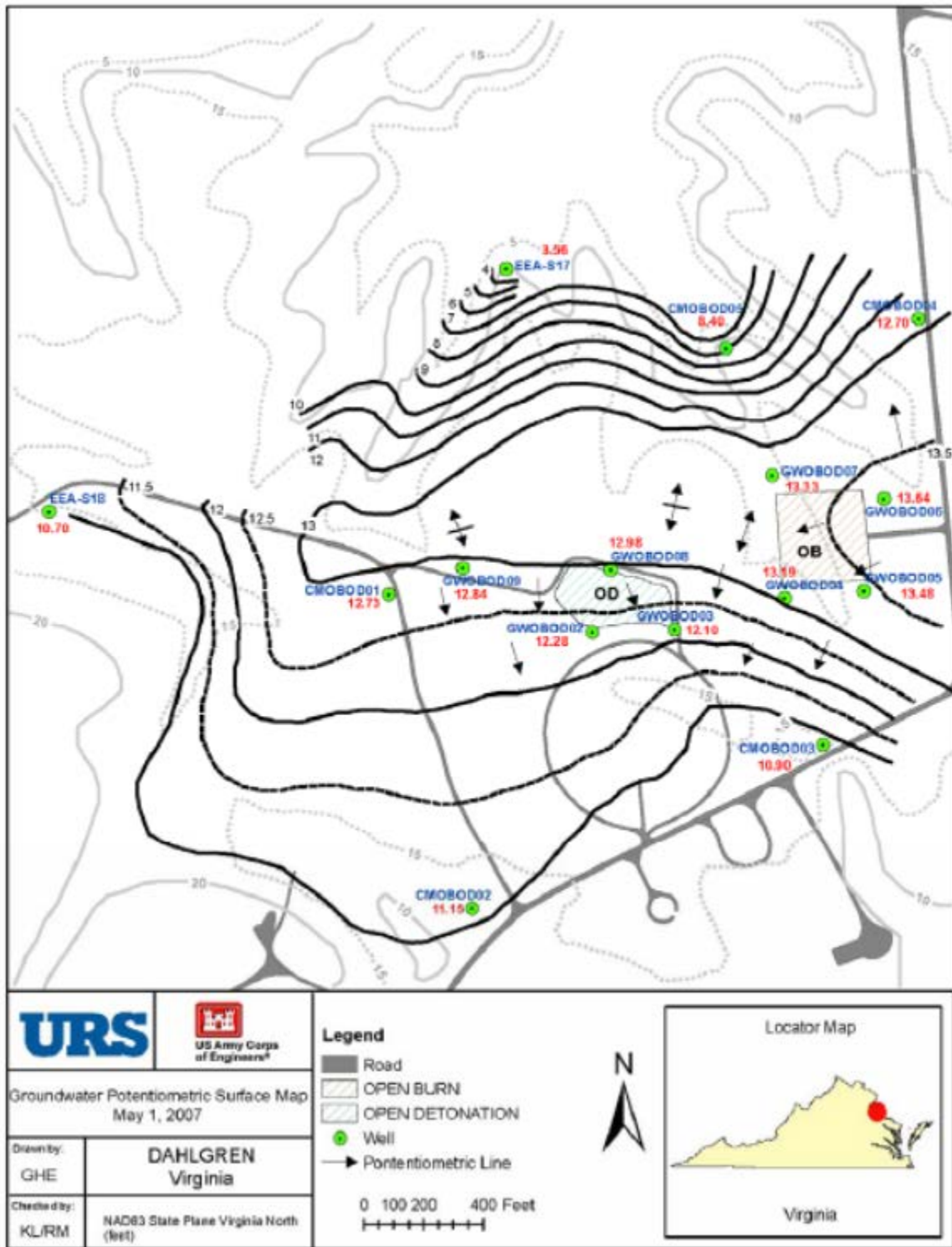
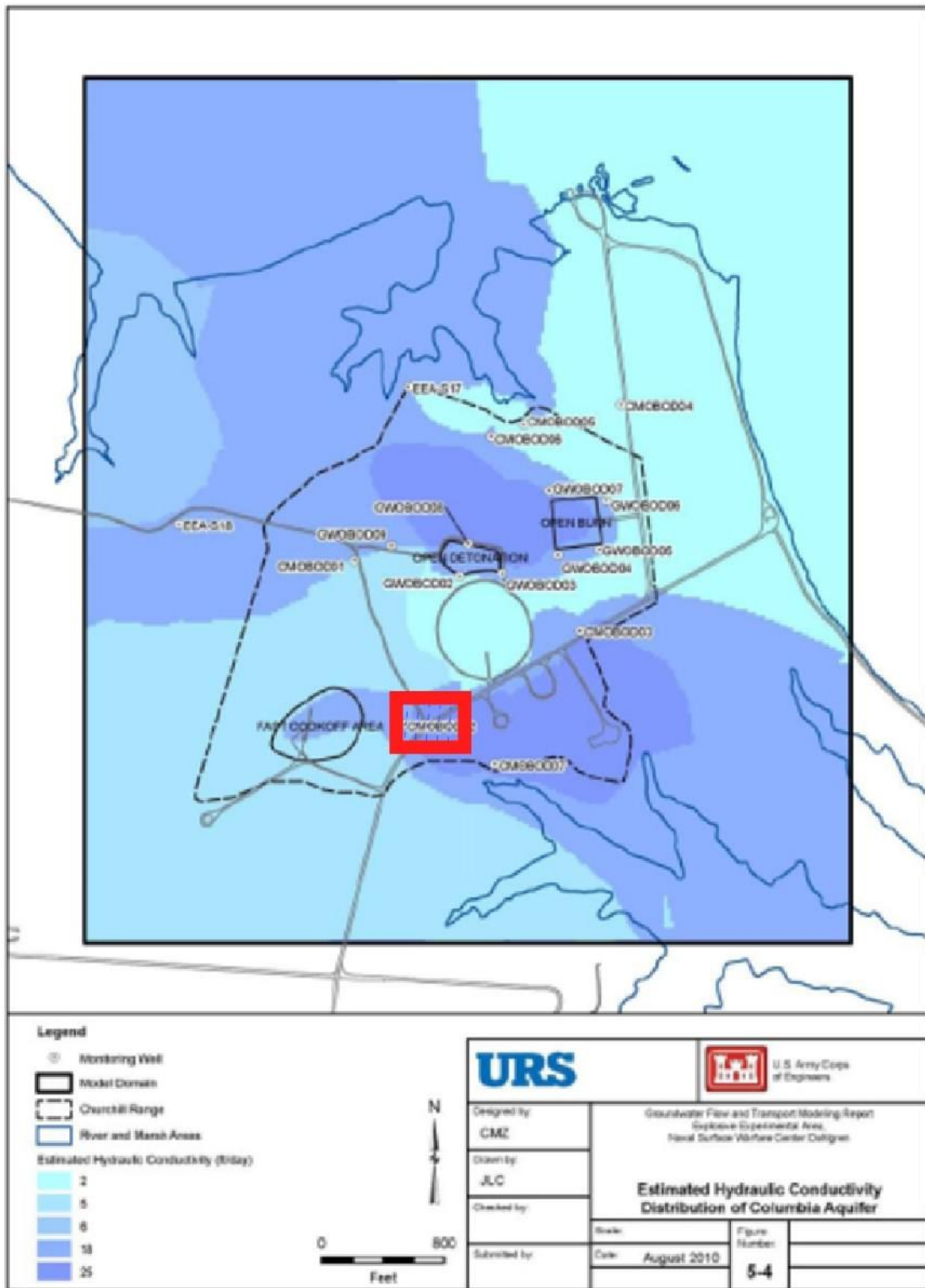

Figure 4.7. Estimated hydraulic conductivity distribution in the Columbia Aquifer. The planned demonstration site is highlighted in red (from URS, 2010).



4.3.5 Groundwater Chemistry

The basic groundwater geochemistry in the Columbia Aquifer across the EEA was evaluated by the USGS in 1996 (Bell, 1996), and the summary table from this report is provided as **Table 4.1**. The water is considered to be typical of shallow groundwater in the coastal plain of Virginia. Overall, the groundwater in the EEA is slightly acidic, with a median pH value of 4.9, and a range from 4.2 to 6.8. Consistent with the low pH, alkalinity in the aquifer is low, averaging 22 mg/L as calcium carbonate (CaCO₃). The bulk of the aquifer is aerobic (although with some anoxic areas), with a median dissolved oxygen of 4.3 mg/L, and a range from 0.2 to 9 mg/L. Other measured parameters are provided in **Table 4.1**. As with hydrogeological conditions across the EEA, the overall groundwater chemistry shows significant variability, in part related to the influence of the Potomac River in some wells, and in other instances the influence of the Nanjemoy-Marlboro confining unit (particularly in the central EEA where the Columbia Aquifer directly overlies this unit).

Table 4.1. Summary of historical water quality data from the Columbia Aquifer in the EEA.
(Bell, 1996)

[all analyses are for the dissolved constituent; results from 20 analyses were used to calculate all statistics unless otherwise noted; --, no SMCL exists for this constituent; °C, degrees Celsius; µg/l., micrograms per liter; mg/L, milligrams per liter; µS/cm, microsiemens per centimeter at 25°C; <, less than; C, carbon; CaCO₃, calcium carbonate; SMCL, U.S. Environmental Protection Agency, (1995) secondary maximum contaminant level; VGWS, Virginia Department of Environmental Quality ground-water standard]

Water-quality constituent	Maximum concentration	Minimum concentration	Median concentration	SMCL or VGWS	Number of samples exceeding SMCL/VGWS
Specific conductance, µS/cm	7,600	48	151	--	
pH, standard units	6.8	4.2	5.9	6.5-8.5	18
¹ Dissolved oxygen, mg/L	9.0	.2	4.3	--	
Calcium, mg/L	220	1.4	13	--	--
Magnesium, mg/L	160	.82	2.2	--	--
Sodium, mg/L	1,100	1.8	6.2	270	1
Potassium, mg/L	27	<.10	1.6	--	--
Alkalinity, mg/L as CaCO ₃	489	4	22	--	--
Sulfate, mg/L	130	.60	16	250	0
Chloride, mg/L	2,100	1.9	4.1	250	1
Fluoride, mg/L	1.5	<.10	.10		--
Silica, mg/L	46	9.9	20		--
Dissolved solids, residue at 180°C, mg/L	4,510	37	106	500	1
² Aluminum, µg/L	1,700	<10	20	--	
Iron, µg/L	40,000	9	230	300	9
Manganese, µg/L	550	10	59	50	11
³ Dissolved organic carbon, mg/L as C	14	.6	1.4	1	16

¹Results from 18 analyses were used to calculate statistics for dissolved oxygen.

²Results from 19 analyses were used to calculate statistics for aluminum.

³Results from 17 analyses were used to calculate statistics for dissolved organic carbon.

4.4 CONTAMINANT DISTRIBUTION

RTD&E activities on the Churchill Range have resulted in contamination of soil and groundwater at some locations. A recent soil characterization conducted by URS in the OB/OD area revealed that the contamination of surface soils with explosives and perchlorate is randomly distributed, which is consistent with the activities performed in this region. The average concentrations of perchlorate and RDX in the regions sampled were 54.9 mg/kg (320 mg/kg maximum) for perchlorate and 3.3 mg/kg (43 mg/kg maximum) for RDX (URS, 2010). Because of the random distribution of constituents, and the likelihood that some energetic materials are present as variably-sized particles, rather than as dissolved or adsorbed phase chemicals, infiltration of these contaminants to groundwater is likely to be intermittent in time and variable in space.

A recent study by URS documented perchlorate and RDX concentrations in groundwater at the Churchill Range from 1998 to 2010 (URS, 2010). These data are presented in **Table 4.2** (perchlorate) and **Table 4.3** (RDX). Based on the data presented, several wells onsite have had elevated concentrations of both perchlorate and RDX during the study period. These include wells GWOBOD02 and GWOBOD03. A series of model simulations were conducted by URS, (2010) to assess groundwater flow from source areas on the range (**Figure 4.8**) and future plume migration pathways with relevant concentrations (**Figure 4.9**).

4.5 TEST PLOT LOCATION

Based on the model simulations from URS, (2010), previous site characterization documents, and discussions with site environmental personnel at NSWC, Dahlgren, a site on the southwestern side of the Churchill Range was chosen as a candidate location for the in situ biobarrier test plot area (TPA). This area is in the vicinity of Well CMOBOD02 to the southeast of the Fast Cookoff area and to the northeast of the Black Marsh (see “black box” in **Figure 4.9**). Well CMOBOD02 currently has perchlorate and RDX concentrations in the range desired for this work (each are currently $>100 \mu\text{g/L}$; see **Tables 4.2 and 4.3**), and historically has had elevated concentrations of both contaminants. Based on the modeling simulations (**Figure 4.8** and **Figure 4.9**), the contamination in this well (and the general surrounding area) is suspected to emanate from the Fast Cookoff area rather than either the OB or OD areas to the north, and appears to occur over a reasonably small areal extent. Another reason to select this general region for the barrier is that the estimated conductivity values (URS, 2010) are high compared to other regions of the site (**Figure 4.7**), and that this region is significantly south of the east-west groundwater divide, with a gradient that appears to be primarily to the southeast (**Figure 4.6**). The groundwater flow direction closer to the divide, near the OB/OD area is more likely to be subject to seasonal effects. This site selection process was communicated to ESTCP in a *Site Selection Memorandum* dated 14 December 2010, which was accepted by program staff on 14 December 2010.

Additional site characterization focused on the proposed TPA was conducted due to the few wells in the area. This work included (1) collection of aquifer solids and groundwater for a series of treatability studies; (2) installation, surveying and sampling of 28 new piezometers screened in the Columbia aquifer to the east and southeast of the Fast Cookoff area; (3) geologic logging of all cores collected during piezometer installation; (3) collection of groundwater elevations from all wells and piezometers on two separate occasions; (4) slug and pump tests in well CMOBOD02; and (5) installation of data loggers into multiple wells to evaluate any tidal influence on

groundwater elevation (due to the proximity of the site to the Potomac River). The results from local site assessment and treatability work are provided in Section 5.2.

Table 4.2. Observed historical groundwater perchlorate concentrations in the Churchill Range (2003-2010).
(URS, 2010; µg/L)

Date	EEAS18	GWOBOD02	GWOBOD03	GWOBOD04	GWOBOD05	GWOBOD06	GWOBOD07	GWOBOD08	GWOBOD09	CMOBOD02	CMOBOD07
Mar-03	ND	1600	900	7.6	5.8	3	38	ND	27	NS	NS
May-03	ND	2100	990	16	4.1	4.2	2.6	27	18	NS	NS
Jul-03	ND	1100	870	10	3.4	2.3	31	31	24	NS	NS
Nov-03	350	990	1100	25	18	ND	15	13	14	NS	NS
Mar-04	0.18	2700	2700	18	ND	1.9	120	0.46	9.2	NS	NS
May-04	ND	210	1300	2.3	31	2.2	46	9.6	7.6	NS	NS
Jul-04	ND	970	1000	12	0.73	2.2	35	7	62	NS	NS
Nov-04	ND	1600	1500	8.6	ND	2.3	99	ND	33	NS	NS
Mar-05	ND	670	870	8.5	0.77	1.5	24	ND	8.8	NS	NS
May-05	ND	440	560	13	0.41	1.1	34	ND	4.7	NS	NS
Mar-06	NS	610	930	8.9	NS	NS	16	NS	NS	NS	NS
Sep-06	NS	620	1200	8.3	NS	NS	39	NS	NS	NS	NS
Mar-07	NS	510	740	4.6	NS	NS	24	NS	NS	340	NS
Sep-07	NS	500	940	1.7	NS	NS	14	NS	NS	190	26
Mar-08	NS	343	624	4.7	NS	NS	10.8	NS	NS	89.7	28
Aug-08	NS	176	701	5.1	NS	NS	12.2	NS	NS	64.9	28.7
Jan-09	NS	295	645	4.7	NS	NS	10.4	NS	NS	51.9	21.1
Apr-09	NS	282	538	3.7	NS	NS	10.2	NS	NS	56.4	25.9
Jul-09	NS	278	702	4.4	NS	NS	5.7	NS	NS	65.5	26.3
Oct-09	NS	123	285	3.2	NS	NS	ND	NS	NS	50	32.5
Jan-10	NS	247	574	4.4	NS	NS	7.7	NS	NS	99	29.7
May-10	ND	226	652	8.3	ND	ND	4.3	ND	ND	129	30.7

ND = Non-detect
NS = No Sampling

Table 4.3. Observed historical groundwater RDX concentrations in the Churchill Range (1998-2010).
(URS, 2010; µg/L)

Date	EEAS18	GWOBOD02	GWOBOD03	GWOBOD04	GWOBOD05	GWOBOD06	GWOBOD07	GWOBOD08	GWOBOD09	CMOBOD02	CMOBOD07
Aug-98	ND	84	45	7.6	ND	ND	ND	0.57	ND	NS	NS
Nov-98	ND	66	46	7.7	ND	ND	ND	ND	0.05	NS	NS
Feb-99	ND	98	68	14	ND	ND	ND	ND	0.34	NS	NS
May-99	ND	53	38	7.7	ND	ND	ND	0.15	ND	NS	NS
Aug-99	ND	69	54	ND	ND	ND	ND	ND	ND	NS	NS
Nov-99	ND	61	25	ND	ND	ND	ND	ND	ND	NS	NS
Feb-00	ND	43.8	32.9	7.8	ND	0.9	ND	ND	ND	NS	NS
May-00	ND	48.2	37.1	7.9	ND	ND	ND	2.2	ND	NS	NS
Oct-00	ND	37.8	36.4	5.8	ND	ND	ND	ND	ND	NS	NS
Feb-01	ND	34.6	29	6.65	ND	ND	ND	ND	ND	NS	NS
Mar-04	ND	29.3	28.8	2.61	ND	ND	2.21	ND	ND	NS	NS
May-04	ND	41	38	2.5	ND	ND	ND	ND	ND	NS	NS
Jul-04	ND	39	40	2.7	ND	ND	ND	ND	ND	NS	NS
Nov-04	ND	35	37	2.6	ND	ND	ND	ND	ND	NS	NS
Mar-05	ND	36	32	1.7	ND	ND	ND	ND	ND	NS	NS
May-05	ND	32	33	1.8	ND	ND	ND	ND	ND	NS	NS
Oct-05	ND	34	37	2.5	ND	ND	ND	ND	ND	NS	NS
Mar-06	ND	31	32	1.6	ND	ND	ND	ND	ND	NS	NS
Sep-06	ND	31	40	2	ND	ND	ND	ND	ND	NS	NS
Mar-07	NS	15	34	ND	NS	NS	ND	NS	NS	100	NS
Sep-07	NS	23	34	1.1	NS	NS	ND	NS	NS	99	0.54
Mar-08	NS	21	31	3.9	NS	NS	ND	NS	NS	110	19
Aug-08	NS	13	25	1.2	NS	NS	ND	NS	NS	94	17
Jan-09	NS	49	49	3.7	NS	NS	ND	NS	NS	110	18
Apr-09	NS	51	32	3.3	NS	NS	0.24	NS	NS	120	24
Jul-09	NS	40	31	3.2	NS	NS	0.26	NS	NS	120	20
Oct-09	NS	37	28	2.9	NS	NS	ND	NS	NS	130	27
Jan-10	NS	55	29	2.2	NS	NS	ND	NS	NS	150	29
May-10	ND	45	29	2.1	ND	ND	ND	ND	ND	160	22

ND = Non-detect
NS = No Sampling

Figure 4.8. Potentiometric surfaces and modeled groundwater flow pathways from the Open Burn, Open Detonation, and Fast Cookoff areas on the Churchill Range
 Figure from URS, 2010. The primary demonstration site is indicated by a bold black square.

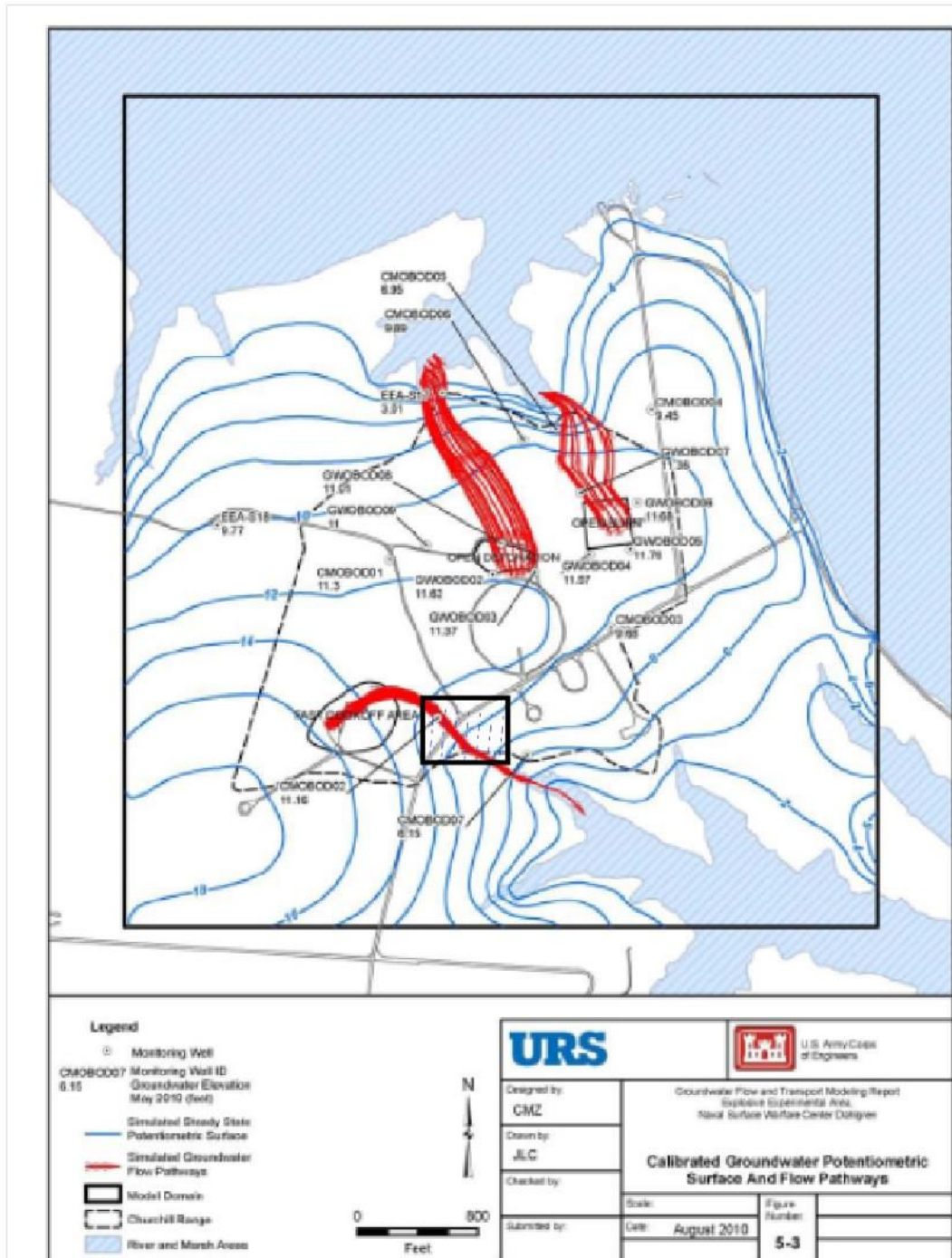
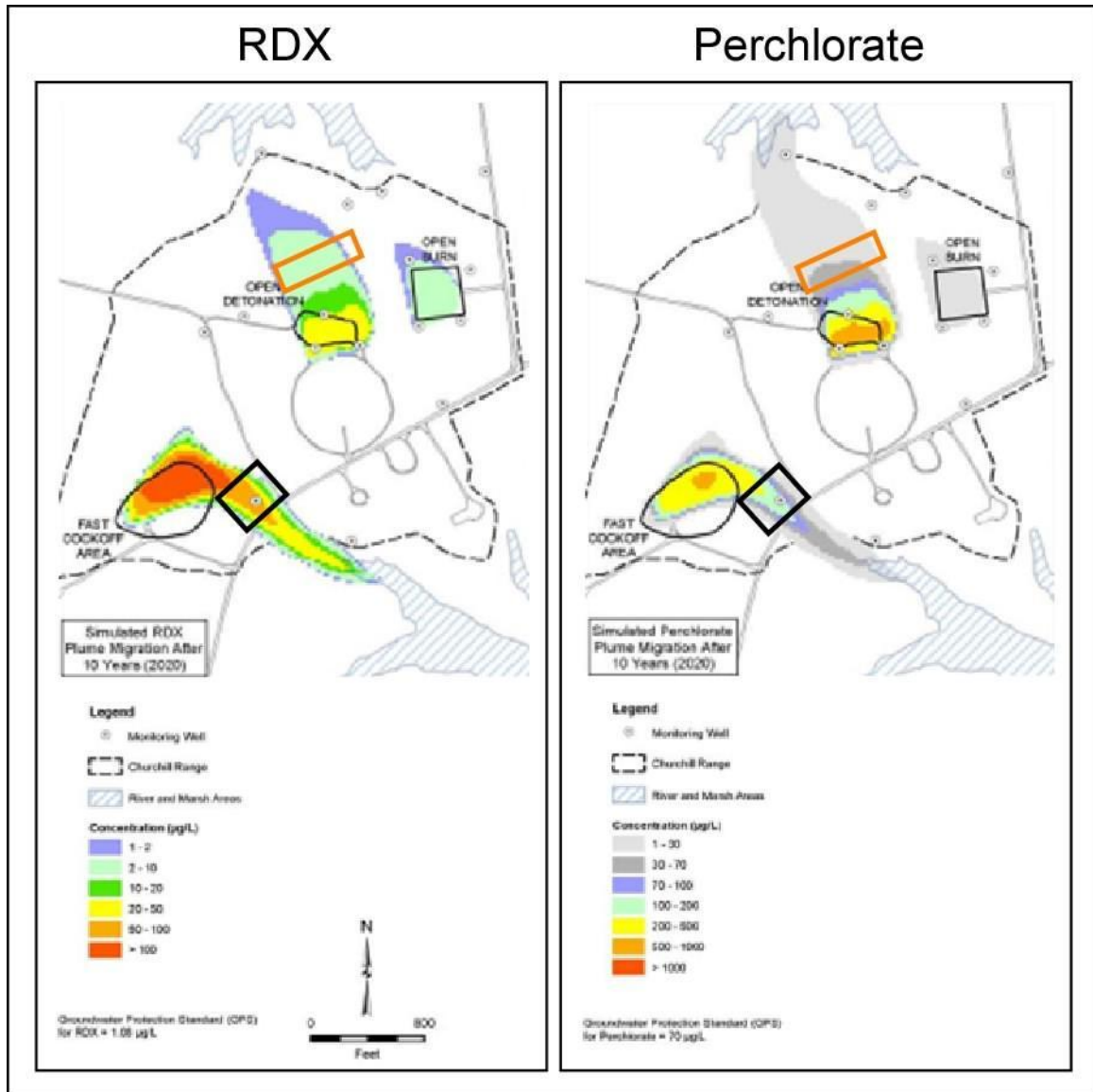

Figure 4.9. Modeled plume migration maps for RDX and perchlorate.
 Figure is from URS, 2010. The primary demonstration site is indicated by a bold black square.



5.0. TEST DESIGN

The following subsections provide detailed description of the system design and testing conducted to address the performance objectives described in **Section 3.0**.

5.1 CONCEPTUAL EXPERIMENTAL DESIGN

The effectiveness of an emulsified oil barrier for in situ treatment of perchlorate and explosives was tested during this project. The experimental plan consisted of initial data review, site assessment, and treatability studies to determine the best location and design for the biobarrier, and the most effective emulsified oil substrate for application at the EEA. The details of this phase of the study are described in Section 5.2. The biobarrier was installed cross-gradient to groundwater flow. The effectiveness of the barrier for reducing migration of perchlorate and explosives in groundwater was determined using a series of groundwater monitoring wells, including two upgradient wells, two wells within the biobarrier, and eight downgradient wells spaced from 2.5 ft to 40 ft downgradient of the barrier. The wells were monitored for perchlorate, RDX and other explosives, field parameters, TOC, fatty acids, dissolved metals, anions, and field parameters. Two initial baseline rounds of groundwater sampling were conducted prior to barrier installation. Once biobarrier installation was complete, 10 groundwater sampling events were conducted that included all demonstration monitoring wells, over a period of 30 months. The details of barrier installation and sampling are provided in Sections 5.3 and 5.4. Depending on hydrological and geochemical characteristics, emulsified oil barriers can effectively provide reducing conditions for more than 5 years (ESTCP, 2006).

Studies were also conducted during the demonstration to identify the specific bacterial communities that are biodegrading RDX through advanced molecular analysis using SIP techniques. The details of these studies are provided in Section 5.4.

Overall, this project is designed to demonstrate that a passive remedial approach can be highly effective and cost-effective for treating explosives and perchlorate in groundwater at an operational DoD range. The site investigation, treatability work, barrier design, monitoring well network, and sampling plan were designed to meet this objective, as described in Section 5. Molecular techniques developed through previous and current SERDP research were also be utilized to assess the organisms responsible for in situ energetics biodegradation as described in Section 5.4. Most critically, the project showed that groundwater treatment and protection can be implemented cost-effectively on an operational range without affecting mission-critical activities.

5.2 BASELINE CHARACTERIZATION ACTIVITIES

Prior to site selection, CB&I reviewed existing site investigation documents and all available hydrogeologic, contaminant concentration, and geochemical data for the EEA at the NSWC, Dahlgren site. Based on these data a test plot area (TPA) was selected in the vicinity of well CMOBOD02, but a significant amount of additional data were required to effectively locate, design and install the biobarrier and the required monitoring well network for the field demonstration plot. The following subsections describe baseline characterization activities that were performed in support of the final demonstration design.

5.2.1 Laboratory Treatability Studies

5.2.1.1 Study Objectives

Laboratory treatability studies were conducted with samples obtained from the TPA. The objectives of the treatability studies were as follows: 1) to determine if indigenous bacteria can be stimulated via emulsified oil addition to biodegrade perchlorate and RDX to below their respective PQLs; (2) to evaluate the effectiveness of different oil formulations, particularly the potential for pH buffered emulsified oils to enhance degradation rates; (3) to estimate the extent of oil adsorption to site sediments; and (4) to estimate kinetics of in situ perchlorate and RDX biodegradation.

5.2.1.2 Sample Collection

Groundwater and aquifer materials were collected for treatability testing from the area influenced by the perchlorate and RDX plumes in the southeast area of the Churchill Range, in conjunction with preliminary site assessment work conducted to confirm the overall extent of groundwater contamination in the region of Well CMOBOD02. Geoprobe direct push cores were collected from 4 locations (Dahlgren 01 to 04) as shown in **Figure 5.1**. Dahlgren 01 and 02 are about 15 and 30 m upgradient of CMOBOD02, respectively (the groundwater flow direction is based on modeling conducted by URS (2010)). Borehole Dahlgren 03 was placed ~15 m side-gradient to 01, and 04 was about 35 m downgradient of the CMOBOD02. For each borehole, aquifer solids were collected in plastic liners from the top of the water table (~1.5 m bgs) to between 6 and 9 m bgs. Groundwater was also collected from each borehole by placing a temporary well in each location (screened in the Columbia formation: see below), and sampling with a peristaltic pump. The groundwater from each well was analyzed for explosives and perchlorate (**Figure 5.1**).

Figure 5.1. Sampling locations for preliminary site assessment and laboratory treatability testing.

Concentrations of perchlorate and RDX in groundwater taken from each borehole are provided.

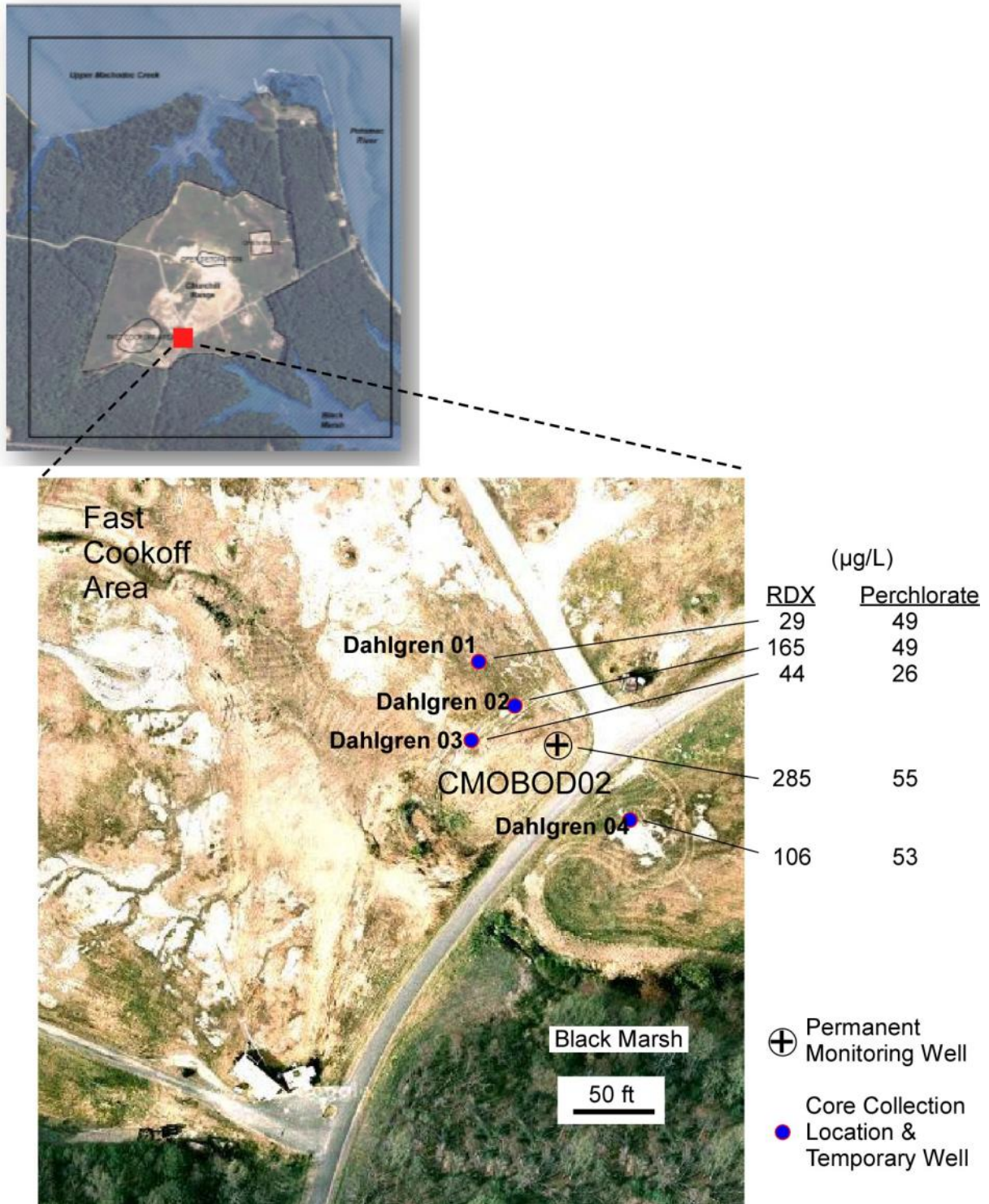

The cores from each of the 4 boreholes (Dahlgren 01 to 04) were collected in liners, sealed on each end with caps, and transported on ice to the laboratory in Lawrenceville, NJ. Each of the cores was split open in the laboratory using appropriate procedures to avoid contamination, subsamples were collected for analysis of adsorbed explosives, basic lithology was logged, and shallow materials from the Columbia aquifer (i.e., that overlying the thick marine clay) from each borehole were homogenized and placed in large glass jars at 4°C for use in treatability tests. Groundwater for treatability testing was collected from CMOBOD02 into a sterile steel keg using a peristaltic pump. Water from the other temporary wells was collected for analyses, but was not used for treatability work.

5.2.1.3 Microcosm Study

A laboratory microcosm study was conducted to determine the effectiveness of emulsified oil for stimulating biodegradation of RDX and perchlorate at the test site location. In addition, because the groundwater pH at the site is relatively low (pH 5 in CMOBOD02), emulsified oils with buffering capacity as well as oils designed to have minimal effect on groundwater pH were tested. Previous studies with samples from the Churchill Range under similar geochemical conditions did not indicate any inhibition of perchlorate or RDX biodegradation due to low pH (see **Figure 2.2**). However, over a long period of in situ incubation, it is possible that any reduction in pH in the barrier area could inhibit biodegradation, since the starting pH is low (e.g. below 5 S.U.).

Three emulsified oils were tested in microcosms as detailed in **Table 5.1**. Each of these products is provided by EOS Remediation, LLC, who holds several patents on the application of emulsified oils for remediation (U.S. Patent # RE40448, U.S. Patent # RE40734). Specifications for the three products to be tested are provided in **Table 5.2**.

Table 5.1. Emulsified oil products evaluated in treatability tests.

EOS 598B42	Standard emulsified oil plus added B ₁₂ vitamins
EOS AquaBupH	A pre-mixed emulsion combining soybean oil with a suspension of a particulate alkaline pH buffering material
EOS 550LS	A low salt version combining emulsified oil and glycerin

Table 5.2. Key components of emulsified oil products.

Ingredient	Weight Percent		
	EOS 598B42	EOS AquaBupH	EOS 550LS
Soybean oil	59.8	40	55
Sodium lactate	4	-	-
Glycerin	-	-	8
Alkaline solids	-	15	-
Emulsifier	10	7	10
Extracts (vitamins)	2	-	-

Microcosm Set-up

The saturated site sediments were used in the studies. Any intervals of solid clay were removed during the homogenization process. A representative subsample was removed from the

homogenized solids and analyzed for total RDX, perchlorate, and organic carbon (TOC). Homogenized sediment (20 g, wet wt) was combined in sterile 160-mL serum bottles with 140 mL of site groundwater collected from well CMOBOD02. Treatments were prepared in triplicate. For anoxic treatments, groundwater was purged with nitrogen for 1 hour prior to use, and all manipulations were performed in a glove bag with a nitrogen headspace. After set-up, all microcosms were thoroughly mixed, then incubated with gentle shaking at 15°C in the dark.

Table 5.3. Quantities of emulsified oil products in microcosms.

	Nutrient	Study Designation	Approx Organic Carbon (%)	Vol per bottle (mL of 1:1 dilution of EOS)
S1	EOS 598B42	EOS	56	2.8
S2	EOS AquaBupH	EOS-AquaBupH	36	4.2
S3	EOS 550LS	EOS-Low Salt	53	2.9

The following treatments were included in the microcosm test:

- (1) *Anaerobic Killed Control:* Bottles were amended with formaldehyde to a final concentration of 1% (v/v) to inhibit microbial activity. This treatment was used to evaluate abiotic losses of target analytes (e.g., leakage from bottles, adsorption/desorption from soil).
- (2) *Anaerobic:* Groundwater slurry with no other amendments, initially purged to remove oxygen.
- (3) *Anaerobic S1, S2, S3:* Groundwater slurry amended with concentrated solutions of the emulsified oils as outlined in **Table 5.3**.
- (4) *Aerobic:* 20 g sediment and 140 mL of groundwater with no other amendments. Room air (sterile-filtered) was added weekly to maintain aerobic conditions.

Microcosm Sampling and Analysis

Microcosms were sampled initially, and then approximately once per week until degradation of perchlorate and RDX was observed. Sampling for the anaerobic treatments was performed in a glove bag with a nitrogen headspace, while the aerobic treatment was sampled under ambient conditions. Samples were removed for measurement of the concentrations of perchlorate by EPA Method 314.0 and RDX (including breakdown products and other explosives that might be present) by EPA Method 8330. The pH of the liquid was also measured during each sampling event using a probe. All analytical was conducted in-house in CB&I's Analytical and Treatability Laboratory.

The data from the microcosm study was used to (1) verify that emulsified oil promoted degradation of both RDX and perchlorate in samples collected from the demonstration location; (2) estimate degradation kinetics; and (3) select the emulsified oil formulation that was used for additional oil retention and soil column testing.

Microcosm Results

Results from the microcosm testing are presented in **Figure 5.2** to **Figure 5.6**. No degradation of HMX, RDX or perchlorate was observed in the killed controls, or in the aerobic or anaerobic treatments that received no carbon amendment (**Figure 5.2**). HMX was degraded after a 50 day lag period in the EOS and EOS-Low Salt treatments (**Figure 5.2A**). HMX degradation in the EOS-AquaBupH treatment could not be confirmed due to interference during the HPLC analysis. This issue was previously observed during studies with cheese whey at Picatinny arsenal (ESTCP Project ER-0425), and was subsequently addressed in this study through additional in-house method development work (See *Treatability Study Report*).

RDX was degraded most rapidly in the EOS-Low Salt treatment, followed by the EOS treatment. In the EOS-Low Salt treatment, RDX reached concentrations $<0.5 \mu\text{g/L}$ within the 2 month study. In the second treatment (EOS), there was a 50 day lag period, but biodegradation occurred very rapidly thereafter (**Figure 5.2B**). No RDX degradation was observed in the EOS-AquaBupH treatment. However, as noted below, the pH in the microcosms receiving this treatment was much higher than is optimal for biodegradation (>9). Thus, it is expected that pH inhibited microbial degradation of RDX in this instance. The RDX metabolites produced during anaerobic biodegradation (MNX, DNX, TNX) were observed intermittently in the EOS-Low Salt treatment over the course of the treatability testing (**Figure 5.3**), but were transient.

Perchlorate was degraded most rapidly and completely in the EOS-Low Salt treatment, with a nearly 80% reduction in the first two weeks (**Figure 5.2C**). Perchlorate concentrations consistently reached $<0.5 \mu\text{g/L}$ within 2 months in microcosms receiving this type of emulsified oil. Partial perchlorate degradation ($\sim 50\%$) also was observed in the EOS-AquaBupH treatment, while no degradation was detected in the EOS treatment. The absence of perchlorate degradation in the EOS treatment is most likely a result of the low pH in microcosms receiving this amendment (pH <4.5). Perchlorate biodegradation has been shown to be inhibited below pH 5, which is the reason we evaluated buffered formulations (Hatzinger, 2005; Wang *et al.*, 2008). RDX degradation does not seem to be inhibited under these conditions based on the microcosm results.

Overall, the data obtained from the microcosm testing indicated that the EOS-Low Salt was the most effective emulsified oil product for promoting the biodegradation of all three target contaminants, and that perchlorate degraded most quickly and HMX most slowly. In addition, the data showed that all three target contaminants could be biodegraded to very low concentrations (e.g., $<0.5 \mu\text{g/L}$ for RDX and perchlorate and $<10 \mu\text{g/L}$ for HMX) within a 60 day timeframe. These results were supportive of the field demonstration.

The EOS-AquaBupH amendment raised the pH of the microcosms from 5 to 9 S.U. for the duration of the test (**Figure 5.4**). This high pH was most likely an artifact of the microcosm set-up in which the soil:water ratio is much lower than expected in an aquifer. Much of the acidity in an aquifer is expected to be in the aquifer solids rather than the groundwater, so this product is unlikely to raise the pH so significantly in an aquifer where the soil:water ratio is much higher. The EOS-Low Salt amendment maintained the pH between 5 and 5.5 S.U. (similar to the aerobic and anaerobic controls), while the EOS amendment did not raise the pH any higher than was observed in the killed or live control (4 to 4.5 S.U.). As noted previously, however, pH values in the 4 to 4.5 range are generally too low for perchlorate biodegradation, and buffering is necessary to

stimulate this process, as was observed previously in a field demonstration at Indian Head NSW (Hatzinger *et al.*, 2006). In this case, potassium carbonate was added to an aquifer to raise pH and lactate was added as an electron donor. Aquifer pH was increased and perchlorate bioremediation of a source area was achieved using these amendments.

Results of a side experiment evaluating the pH of various mixtures of the emulsified oil products are presented in **Figure 5.5**. As expected, the pH was in direct proportion to the percentage of EOS-AquaBupH added to the microcosm bottles. A ratio of 75:25 (v:v) or greater of EOS-AquaBupH was required to raise the pH of the EOS treatment above that of the site groundwater. In contrast, even as little as 6% (v:v) of EOS-AquaBupH added to EOS-Low Salt raised the pH above that of the site groundwater.

Based on the positive microcosm results, the EOS-Low Salt product was selected for further oil retention testing. The EOS-AquaBupH product raised the pH too high when used alone, but when mixed in various proportions with the EOS or EOS-Low Salt products, pH in the range of 5 to 8 could be achieved and maintained (**Figure 5.5**). As a result, a mixture of the oil products was selected for testing in column studies.

Figure 5.2. Degradation of HMX, RDX and perchlorate in aquifer microcosms.
 (Average and standard deviation of triplicate microcosms of each treatment).

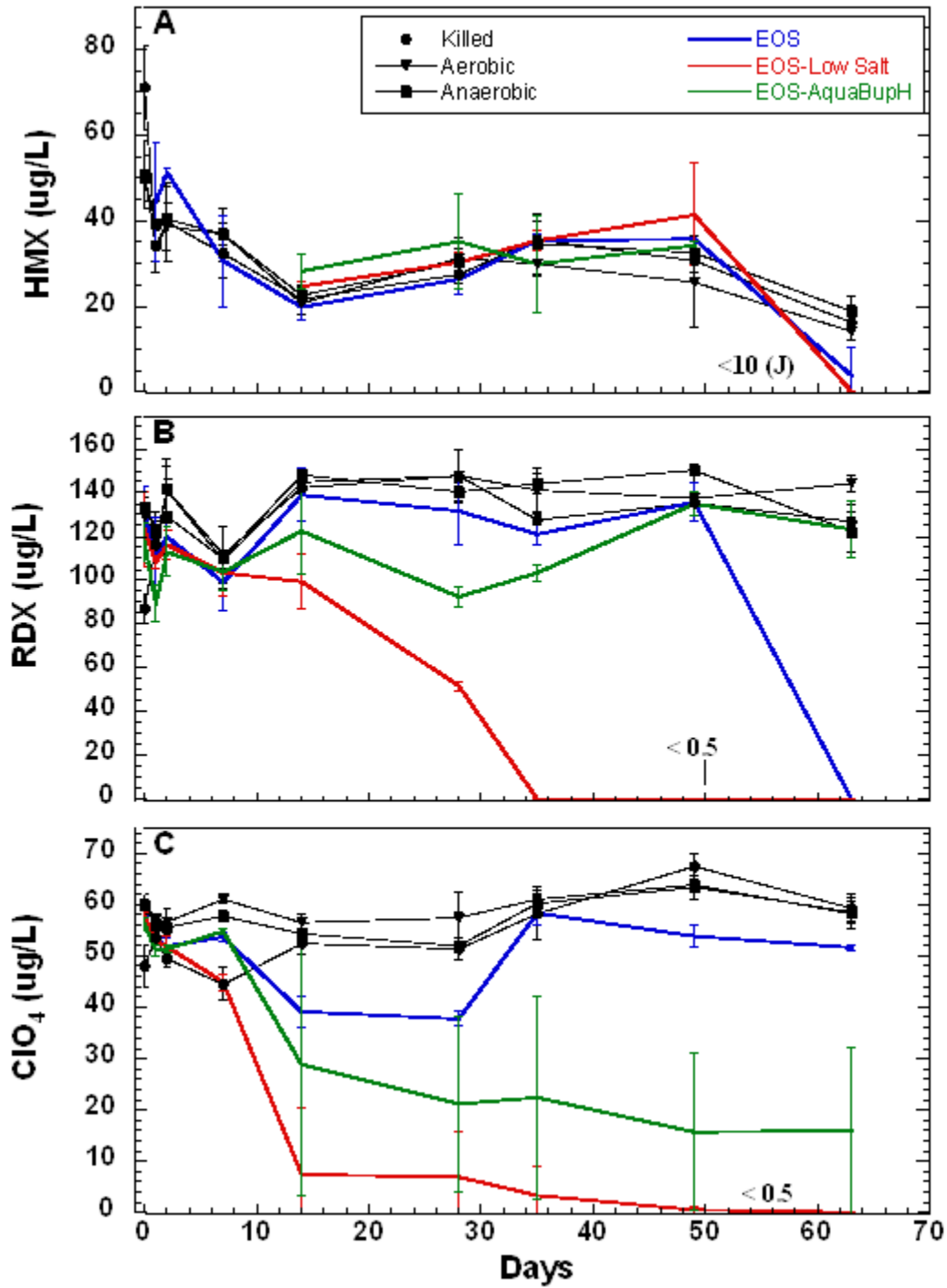

Figure 5.3. Detection of MNX, DNX, and TNX in the site-derived microcosms.
 (Average and standard deviation of triplicate microcosms of each treatment).

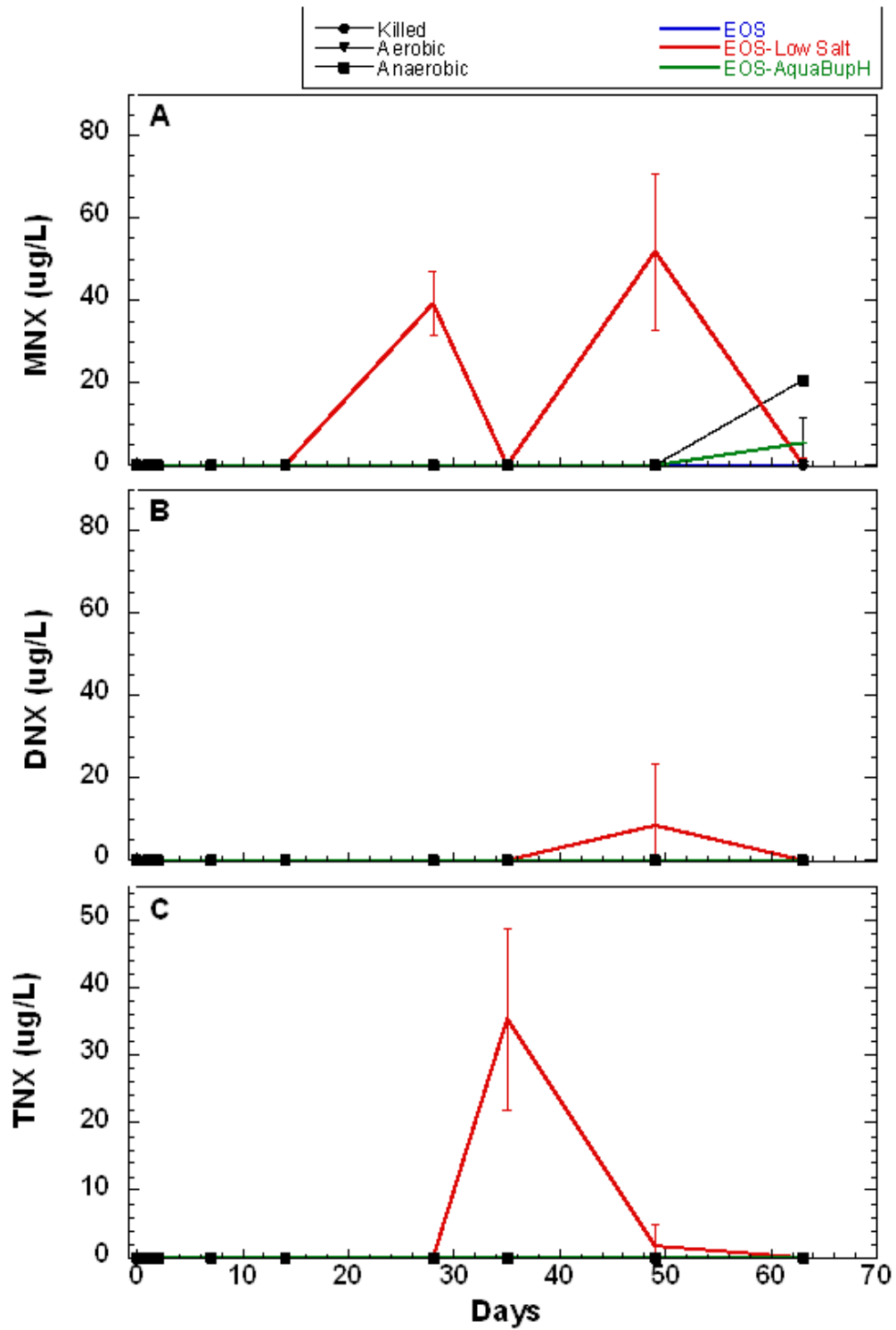

Figure 5.4. Measured pH in the site-derived microcosms over time.
 (Average and standard deviation of triplicate microcosms of each treatment).

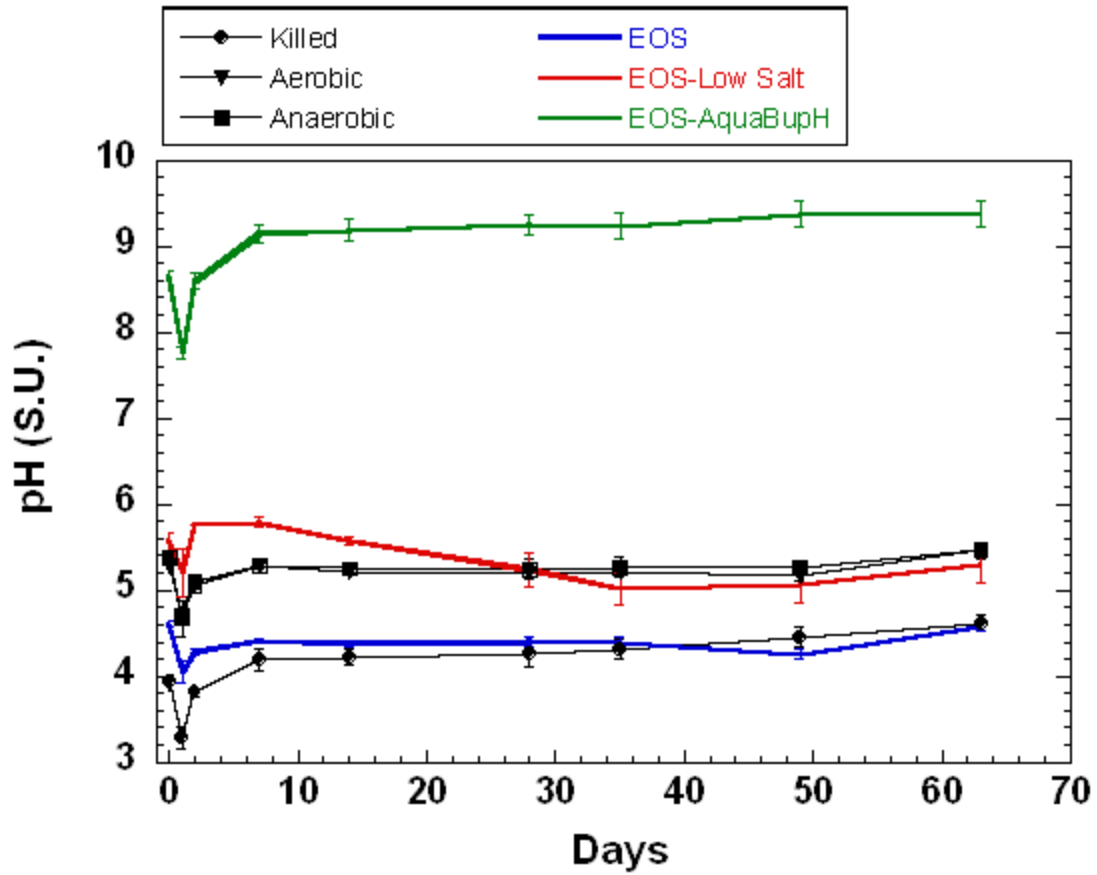
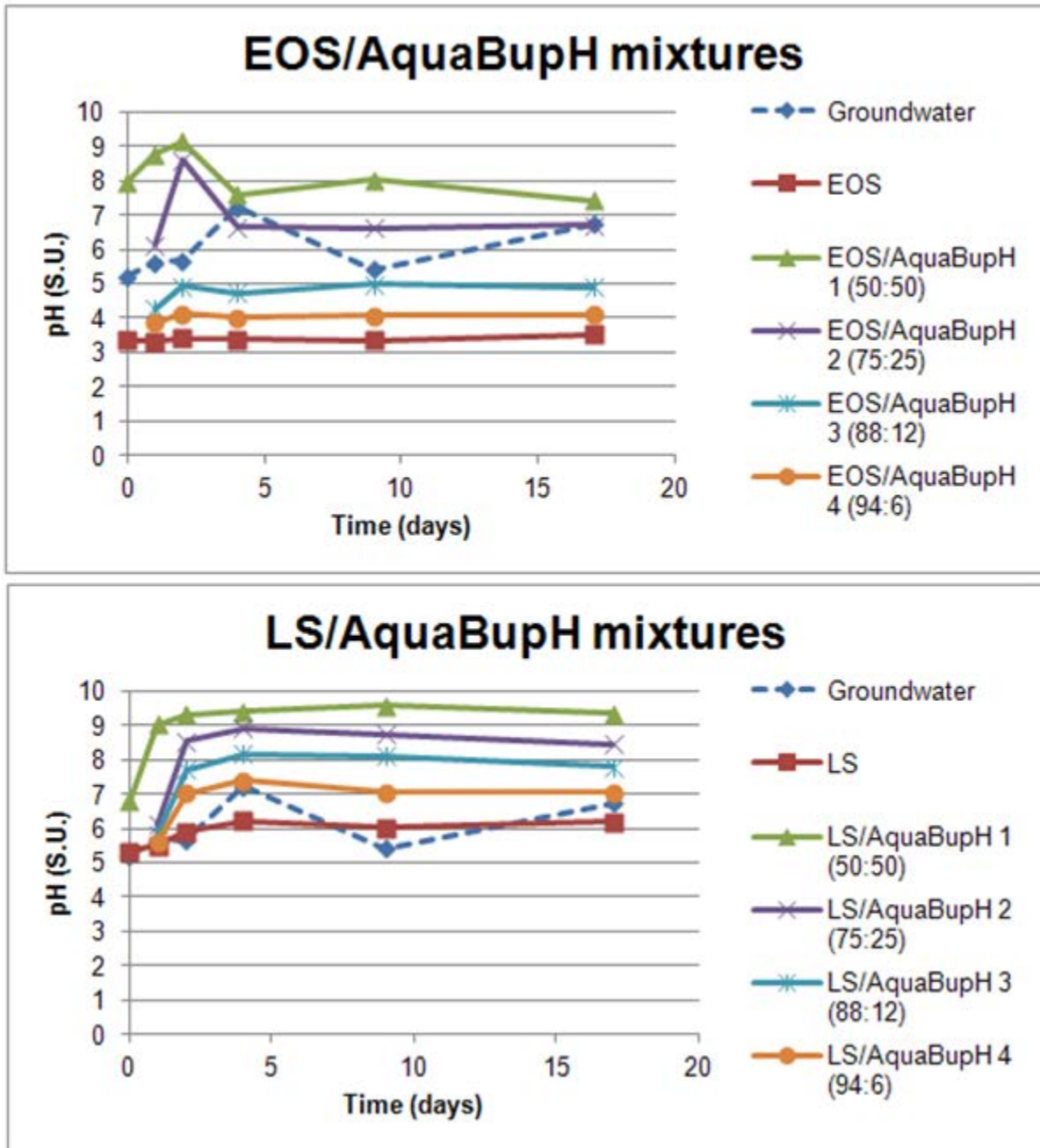

Figure 5.5. Measured pH over time in site groundwater amended with various mixtures of the emulsified oil products.



5.2.1.4 Emulsified Oil Retention Testing

A test of emulsified oil retention on site sediments was performed as described in Borden *et al.* (2008b). These studies were performed to estimate oil transport and retention in the field, which is necessary to size the biobarrier.

Oil Retention Set-up

Briefly, homogenized site sediment was packed into a PVC pipe (1" ID x 6" length) to a bulk density of $\sim 1.6 \text{ g/cm}^3$. The ends of the pipe were closed with caps equipped with fittings to allow connection of tubing. Three pore volumes (PV) of EOS-Low Salt were prepared as a 12% dilution (% emulsified oil by weight) in site groundwater and pumped into the bottom of the column. After the oil was added, the influent was changed over to the site groundwater. Three pore volumes of the effluent were collected sequentially, homogenized, and analyzed for total organic carbon (TOC; as a surrogate for the emulsified oil). The volume of effluent collected was recorded.

The columns were then cut into sections (2" each). The sediment in each section was removed and homogenized. The TOC in the sediment of each section was measured in duplicate. The TOC data were then used to determine oil retention vs. distance within the column. The data also were compiled to determine the emulsified oil mass balance.

Oil Retention Results

The mass balance data from the oil retention experiment are presented in **Table 5.4**. Over 90% of the injected oil was recovered in the effluent, while 8% was retained in the soil. Using the equation from Borden *et al.* (2008b), the maximum oil retention value of the site aquifer material (OR_M) was calculated to be 0.0019 g/g. This is comparable with previously published values, e.g., 0.0037 g/g (Borden, 2007). Interestingly, the residual oil content in the soil increased slightly from the influent end to the effluent end of column, indicating possible coalescence and deposition of oil onto the soil matrix at distances farther from the point of injection (**Figure 5.6**).

Table 5.4. Mass balance for the oil retention testing.

	mg TOC	%
Pumped into column	11029	100
Recovered in effluent	10059	91
Remaining (calculated)	970	9
TOC in column soil (measured)	912	8
MASS BALANCE		99

Figure 5.6. Residual oil retention as a function of distance from injection point.

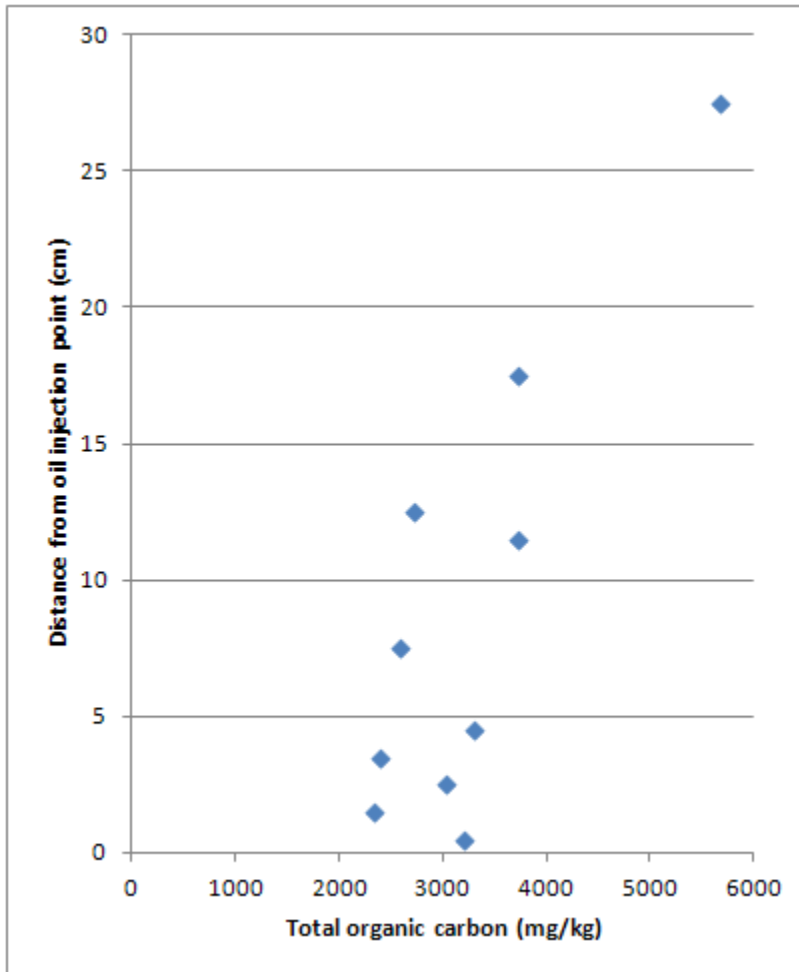

5.2.1.5 Column Biodegradation Testing

A column study using aquifer materials and site groundwater was performed to more fully examine the kinetics of RDX and perchlorate degradation and finalize selection of the appropriate emulsified oil amendment to be used during the field demonstration.

Column Design and Set-up

The columns used for this test are shown in **Figure 5.7**. Three columns were prepared. Each column was made from 7 cm ID aluminum tubing cut to a length of 30 cm. Lexan end plates were prepared and held in place with threaded rods. A 3-way-stopcock was placed on both the influent and effluent end of the column. Side sampling ports were placed at 10 cm and 20 cm to allow collection of effluent with groundwater flow. A Teflon diffuser ring was placed at the bottom of the column to equalize flow through the packed sediment. The total volume of each column was approximately 1200 cm³.

Site sediment collected from the Fast Cookoff plume area was homogenized and packed into the columns, resulting in a bulk density of approximately 1.81 g/cm³ (dry wt basis) and a pore volume of 240 mL. Groundwater was collected from well CMOBOD02 at the field site in a large steel keg (60 L) and used as the column mobile phase. The groundwater feed was set to approximately 6 to 7 mL/h, equivalent to 0.2 m/d (0.6 ft/d).

A bromide tracer test was performed with each column to verify flow conditions and calculate the pore volume. A pulse of NaBr was pumped into the column at a concentration of 100 mg/L, followed by site groundwater. Effluent samples were collected and analyzed for bromide using ion chromatography. The tracer curves for the three columns are shown in **Figure 5.8**. All three columns reached a C/C_0 Br concentration in the effluent at the same elapsed time and PV (1 PV = 240 mL).

Equilibration with site groundwater was then performed. The dissolved oxygen and pH of the influent groundwater and the effluent of each column were measured. A split of the influent groundwater and the effluent from each column was directed through a solid phase extraction (SPE) column over several days to collect and concentrate the explosive compounds. Explosives were then eluted from the SPE columns and analyzed for explosives (HMX, RDX, and RDX breakdown products) by EPA Method 8330. Additional samples of the effluent were collected and analyzed for perchlorate (EPA Method 314.0), anions (EPA Method 300.0), and TOC (EPA Method 415.1). Periodic samples were collected and preserved with nitric acid for later analysis of dissolved metals (Target Analyte List (TAL) metals).

When the columns were assessed to have equilibrated, they were designated with their respective treatments (**Table 5.5**).

Table 5.5. Treatment assignments for the column testing.

Column	Treatment	Description
Col 1	EOS-Low Salt	3 pore volumes of 12% (w:v) of EOS 550LS
Col 2	Control	No amendments
Col 3	EOS-Low Salt/AquaBupH	3 pore volumes of 12% (w:v) of a 75:25 (v:v) of EOS 550LS:EOS AquaBupH

These treatments were based on results from the previous microcosm studies (Section 4.3.1). The amendment addition was performed at a flow rate of 30 mL/h, followed by a 3 pore volume flush of groundwater. The control column had groundwater pumped through at the higher flow rate but no oil addition. The flow rate was then reduced back to approximately 6 mL/h. Influent and effluent samples were monitored as described above. The aquifer column test continued until concentrations of RDX and perchlorate in the effluent were reduced to <1 µg/L for RDX and <4 µg/L for perchlorate and when the effluent concentrations stabilized such that degradation rates could be extrapolated over a longer flow path (i.e., if the residence time in the columns is not sufficient to achieve the low contaminant concentrations, since residence times in the field are not constrained by column length).

Column Results

The pH of the influent groundwater was the same or lower than the column effluent for the duration of the experiment (**Figure 5.9**). The combination of EOS-Low Salt:EOS-AquaBupH maintained the pH of the column effluent above 6 S.U., whereas the control column and the column amended with EOS-Low Salt had effluent pH in the 5.0 to 5.5 S.U. range. As previously noted, previous studies have indicated that a pH greater 5 and preferably greater than 5.5 is optimal for biodegradation of perchlorate (Hatzinger, 2005; Wang *et al.*, 2008). The drop in influent pH at the time of emulsified oil addition was caused by the intentional addition of carbon dioxide to the headspace of the groundwater reservoir (~60 L keg). This addition was made specifically to reduce the groundwater pH to the lower range found at the Dahlgren site in order to fully assess the influence of the buffered emulsified oil. The groundwater influent dissolved oxygen (DO) also was reduced from ~6 mg/L to 4 mg/L by this addition (**Figure 5.10**).

TOC concentrations in the effluent increased immediately after emulsified oil was added to two of the columns (Col 1 and Col 3), then decreased slowly with time, as expected (**Figure 5.11**). Reducing (anoxic) conditions were generated in the EOS-amended columns as the added carbon was degraded, as reflected in the rapid decrease in the effluent concentrations of both nitrate and sulfate, indicative of typical biological reduction of both of these anions (**Figure 5.12**).

Perchlorate also was rapidly biodegraded in the two columns with the emulsified oil formulations, although the rates were somewhat higher in Col 3, which received the buffered EOS mixture (**Figure 5.13**). These data are consistent with previous findings showing that perchlorate bioreduction can be inhibited at low pH. The data also confirm our previous microcosm studies from this site showing that emulsified oil promotes rapid perchlorate biodegradation. No significant degradation of perchlorate was observed in the control column (Col 2), and only slight losses of sulfate and nitrate were apparent compared to influent concentrations. Steady state degradation rates for the emulsified oil amended columns are shown in **Table 5.6**.

Table 5.6. Apparent steady-state degradation rates of target compounds.

Column	Treatment	Degradation Rate ($\mu\text{g/L/d}$)		
		HMX	RDX	Perchlorate
1	EOS-Low Salt	0.6 ± 0.2	3.1 ± 0.5	0.7 ± 0.3
3	EOS-Low Salt/AquaBupH	0.7 ± 0.2	3.1 ± 0.6	0.8 ± 0.1
2	Control (no amendment)	0.6 ± 0.2	2.8 ± 0.6	0

Concentrations of influent and effluent RDX and HMX are shown in **Figure 5.14** and **Figure 5.15**, respectively. We initially assumed that the equilibration period for HMX and RDX would require less than approximately 30 days of operation due to their physiochemical characteristics (low K_{ow} values in particular). During this time, some adsorption of each of these nitramine explosives to the aquifer solids was expected. Because the columns were prepared from homogenized solids, we anticipated that there could be significant new adsorption sites available for RDX and HMX present in the influent groundwater. For Col 1, the influent and effluent RDX and HMX concentrations reached the same values after ~40 days of operation (RDX and HMX were added at Day 41 of operation) and remained equivalent prior to emulsified oil addition. For Col 2 and Col 3, the effluent RDX and HMX approached but did not reach the influent concentrations after nearly five months of operation with these nitramines in the influent groundwater.

The reasons for the difference among the three columns, which were replicates up to the time that emulsified oil is added (Day 174) are unclear. Based on the data for the common RDX intermediates, MNX, DNX, and TNX (**Figure 5.16**), it appears that some RDX degradation was occurring in Col 2 and Col 3 during the initial 5 month period. It should be noted however, that the combined quantities of these intermediates represents only a small percentage (<15%) of the RDX loss across the two columns. Detectable, but lower, concentrations of these intermediates (particularly DNX and TNX) were observed in the effluent from Col 1, suggesting some level of RDX biodegradation in this column as well. However, interestingly, there was no similar evidence of nitrate, sulfate (**Figure 5.12**) or perchlorate (**Figure 5.13**) degradation in any of the columns. In fact, the effluent concentrations of each of these anions rapidly reached the influent concentration in each of the 3 columns. The loss of RDX and HMX without any similar loss of nitrate or perchlorate (both of which are readily biodegradable under anoxic conditions), suggests that the apparent loss of RDX and HMX in the columns may reflect either abiotic losses (adsorption or degradation) or aerobic biodegradation.

RDX and HMX decreased rapidly in Col 1 and Col 3 after the emulsified oil was added (**Figure 5.14** and **Figure 5.15**, respectively). However, decreases also were apparent in the control column (Col 2) which only had groundwater pumped in at a higher rate while the others were receiving the oil substrates. Degradation kinetics were essentially the same for both the EOS-Low Salt (Col 1) and the EOS-Low Salt:EOS-AquaBupH mixture (Col 3) (**Table 5.6**), although a slight rebound in HMX was observed in the EOS-Low Salt column near the end of the experiment (**Figure 5.14**).

The aquifer sediment collected from Dahlgren and used in the columns had a significant fraction of TOC (145 mg/kg of the homogenized aquifer solids), and there was evidence of iron deposits and significant quantities of clays within the aquifer cores (**Figure 5.17**). Although the iron was not quantified and/or speciated, it is feasible that iron minerals were catalyzing the abiotic reduction of RDX and HMX in Col 2 and Col 3, and to a lesser extent in Col 1, as described above. It is also possible that enhanced adsorption to clays and organics and/or biodegradation with organic matter as co-substrate plays a role in this process. The fact that similar natural attenuation was not observed in previous microcosm experiments suggests that the soil matrix and/or the soil/water ratio are critical in the loss process or processes.

One significant component of the initial loss of RDX and HMX across the columns may be adsorption to organic matter and/or clays. It is possible that many new binding sites were exposed to the groundwater flow path during homogenization of the aquifer solids. Another possible factor is the abiotic reduction of RDX by iron (Fe), and in particular Fe(II)-surface complexes. Several recent papers suggest that RDX is susceptible to abiotic reduction by a variety of Fe(II)-organic ligands, Fe-oxides (e.g., magnetite) and other Fe(II) mineral complexes (Boparai *et al.*, 2010; Gregory *et al.*, 2004; Kim and Strathmann, 2007; Oh *et al.*, 2008). The abiotic reduction with many of these Fe minerals/ligands proceeds through MNX, DNX, TNX, similar to biological reduction, so some occurrence of these nitroso-derivatives would be expected. Moreover, perchlorate is unlikely to be abiotically degraded by these minerals, as it is highly stable in solution, even to abiotic reduction by zero-valent Fe (Schaefer *et al.*, 2007). This is consistent with the column results, as perchlorate degradation was not observed. Finally, aerobic biodegradation of RDX and HMX in these columns is a possibility, since the influent DO during the initial equilibration period was approximately 6 mg/L. Aerobic biodegradation of RDX by pure cultures has been described by several groups (Fournier *et al.*, 2002; Thompson *et al.*, 2005), and although much less widely studied, aerobic biodegradation of HMX also has been reported (Harkins *et al.*, 1999; Van Aken *et al.*, 2004).

The addition of the emulsified oil resulted in changes in the soluble concentration of several metals compared to the unamended control. **Table 5.7** indicates increased concentrations (in red) and decreased concentrations (in green) in effluent of the treatment columns relative to the effluent of the control column. Influent concentrations are also presented. Data for samples collected 30 and 75 days after emulsified oil addition are presented. No changes were observed for Sb, Be, Hg, Se, Ag, Ti, or V. There was a rapid and dramatic increase in Fe and Mn in the oil amended column effluents, indicating that robust reducing conditions were achieved. Under such conditions, biological reduction and mobilization of both Fe and Mn is common. Small increases in concentrations of other metals, including As, Cd, and Co were observed (<20 µg/L at a maximum), while other metals, including Pb and Cr, decreased. Arsenic and other metals were monitored during the field demonstration. It is predicted that dissolved Fe concentrations in the vicinity of the biobarrier will increase to >50 mg/L and that Mn will reach 1 mg/L based on the column experiments. This is fairly typical after emulsified oil injection to the subsurface. However, these metals are expected to re-precipitate downgradient of the barrier as the groundwater gets re-oxygenated. A slight increase in groundwater As also was observed in the oil-amended columns, but total As concentrations did not exceed 20 µg/L, even under very reducing conditions. Thus, the data suggest that high As concentrations are unlikely to be observed downgradient of the

barrier. Similar to Fe and Mn, any mobilized As is expected to precipitate a short distance downgradient of the barrier.

Table 5.7. Metal concentrations in column effluent after emulsified oil amendment.

	Al	As	Ba	Cd	Ca	Cr	Co	Cu	Fe	Pb	Mg	Mn	Ni	K	Na	Zn
30 Days																
INFLUENT	73.1	<4.2	15.1	<0.5	1990	<1.1	<5.8	395	74.9	36.9	1100	8.29	30.2	841	6350	355
Col 2 (Control)	42.5	<4.2	48.8	2.46	22500	<1.1	<5.8	43.8	61.7	3.79	3510	225	13.6	1990	5870	51.2
Col 1 (EOS LS)	29	<4.2	10.5	0.685	19400	<1.1	12.5	19.4	7800	5.73	3640	707	21.2	1210	6000	285
Col 3 (LS:AquaBupH)	19.4	4.93	16.1	<0.5	30700	102	13.5	11.7	16600	4.55	26800	826	97.7	1060	5490	40.8
75 Days																
INFLUENT	69.1	<4.2	18.3	<0.5	1960	<1.1	<5.8	747	54.6	33	1080	7.79	17.5	949	5940	538
Col 2 (Control)	20.6	<4.2	27.8	1.07	10300	1.13	<5.8	39.2	1200	6	1510	71.2	8.76	1280	6140	38.3
Col 1 (EOS LS)	<6.5	5.77	7.99	1.96	10600	<1.1	7.97	5.47	40000	4.23	2200	474	9.83	647	5740	13.6
Col 3 (LS:AquaBupH)	<6.5	17.5	8.17	3.41	15600	<1.1	9.66	3.21	69200	3.72	13900	788	8.96	648	5430	15.4

Summary of Column Study Results

At the conclusion of the planned column tests, the RDX concentration in the influent to each was increased to approximately 3 mg/L. The same flow rate was maintained, and samples from the influent, effluent, and each of the side ports were collected and analyzed. The RDX was increased to determine if there was any difference in degradation rates of RDX and perchlorate across each of the columns. **Figure 5.18** presents the profiles of RDX and perchlorate as a function of distance from the influent end of the columns. While some RDX degradation was observed in the control column (Col 2), RDX concentrations decreased much more rapidly in the EOS-Low Salt (Col 1) and the EOS-Low Salt:EOS-AquaBupH mixture (Col 3) columns. Perchlorate was not observed to degrade at all in Col 2, whereas rapid degradation was observed in Col 1 and Col 3 (concentrations were below the detection limit of 0.4 µg/L). A similar pattern was observed for nitrate and sulfate in the oil-amended columns compared to the control column (**Figure 5.19**), further supporting the idea that the control column remained aerobic in bulk and that any processes resulting in RDX loss were not likely reductive in nature.

In combination with the microcosm results presented in Section 5.2.1.3 and the oil retention data from Section 5.2.1.4, the column study results support the use of the 75:25 EOS-Low Salt:EOS-AquaBupH mixture for the field demonstration. Section 5.3 details the emplacement of the emulsified oil biobarrier for the remediation of comingled RDX and perchlorate in the groundwater at NSWC Dahlgren based on these findings.

Figure 5.7. Column design for laboratory treatability testing.

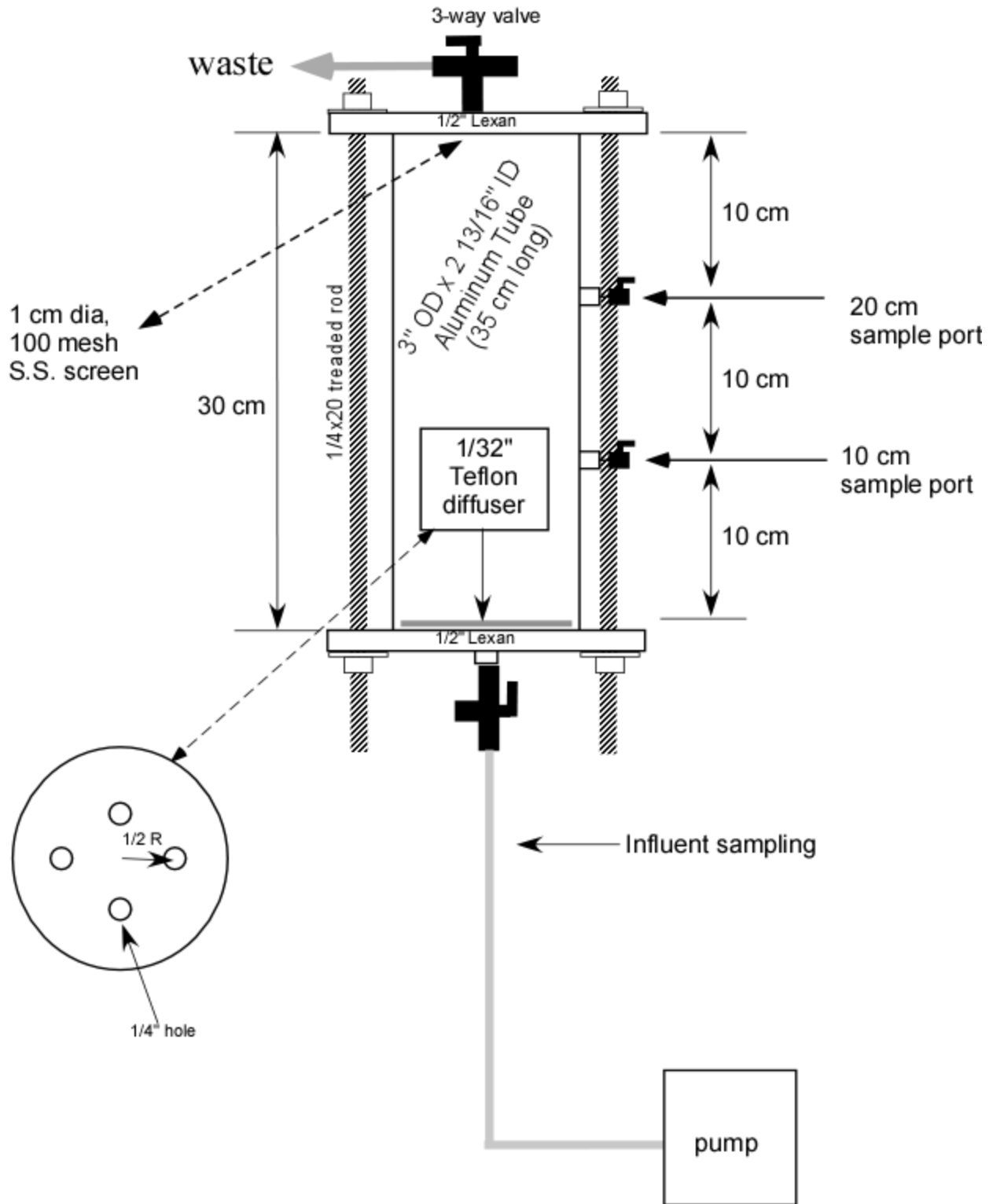

Figure 5.8. Bromide tracer results for the three flow-through columns.

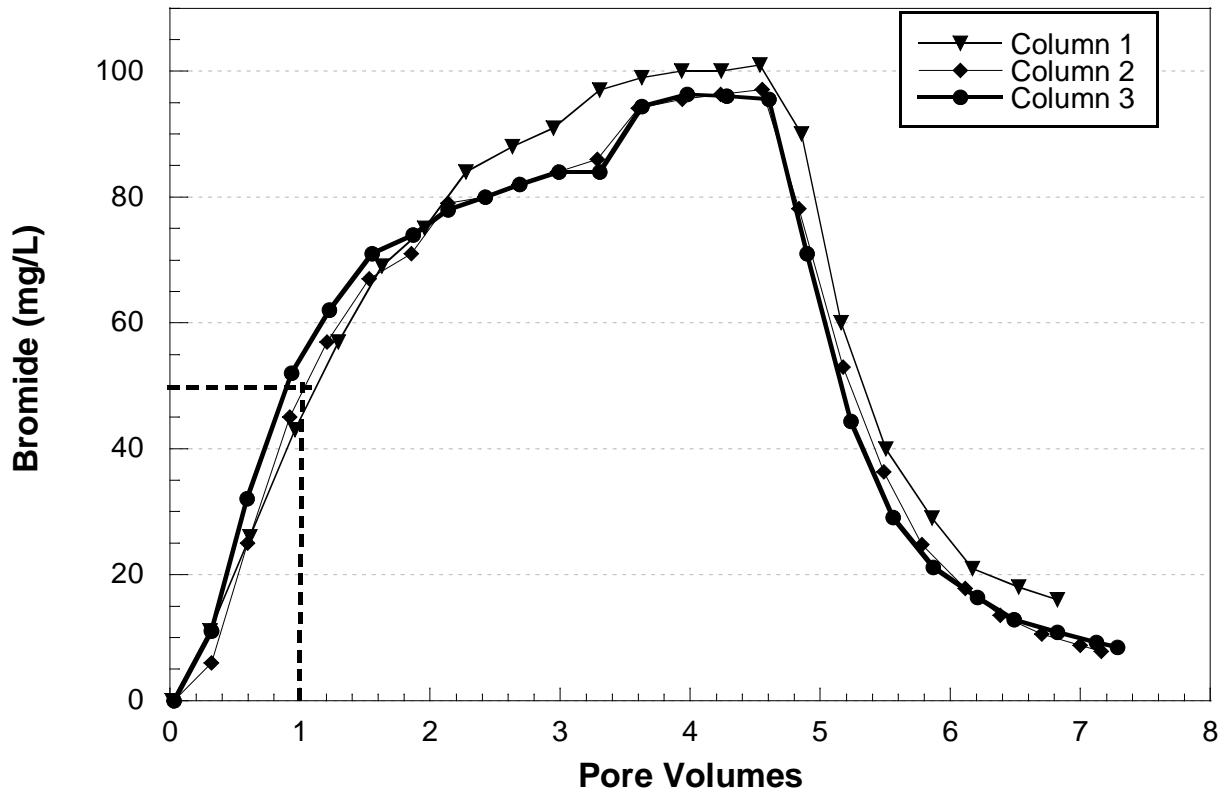

Figure 5.9. The pH in the influent groundwater and the effluent of the three flow-through columns.

The dashed line indicates the time of emulsified oil addition.

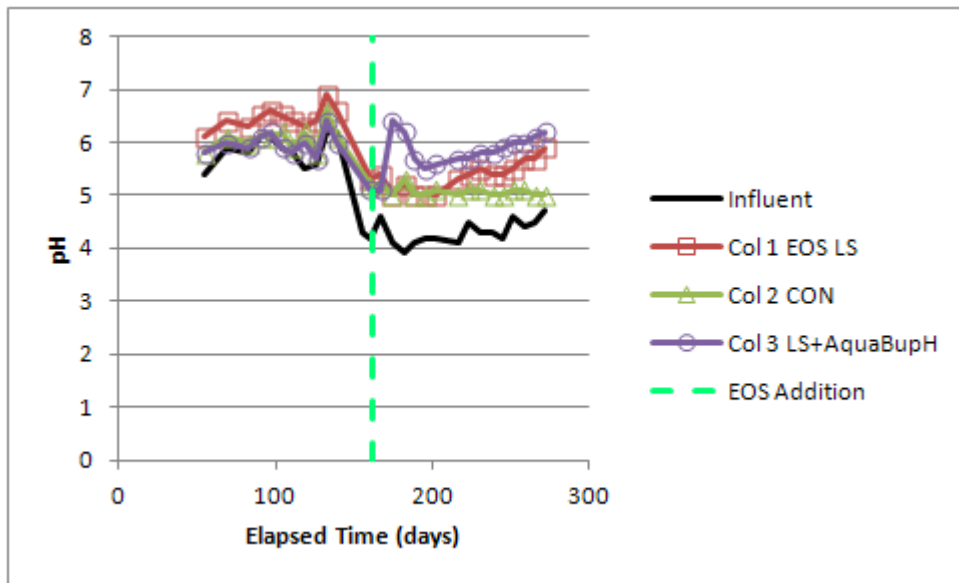

Figure 5.10. Dissolved oxygen in the influent groundwater and the effluent of the three flow-through columns.

The dashed line indicates the time of emulsified oil addition.

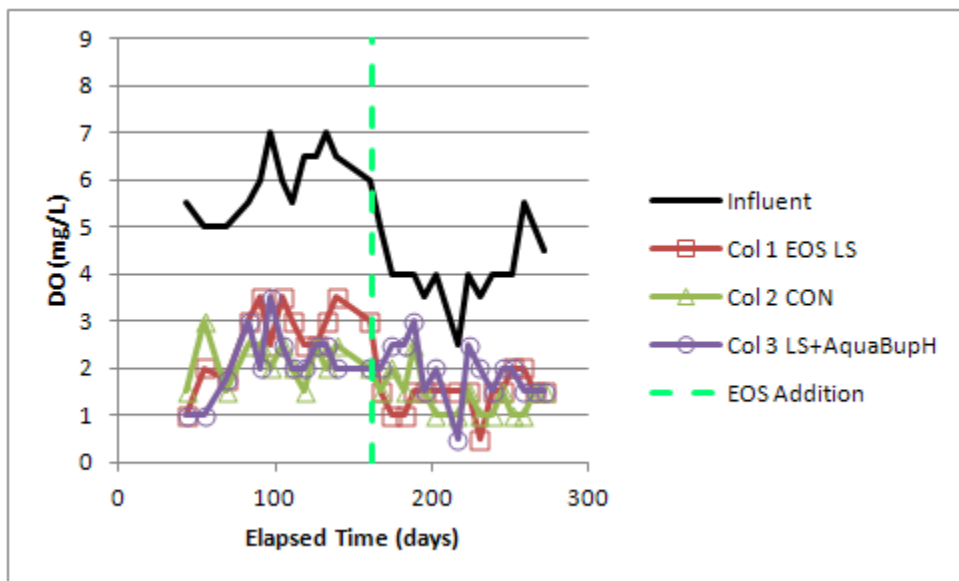

Figure 5.11. TOC in the influent groundwater and the effluent of the three flow-through columns.

The dashed line indicates the time of emulsified oil addition.

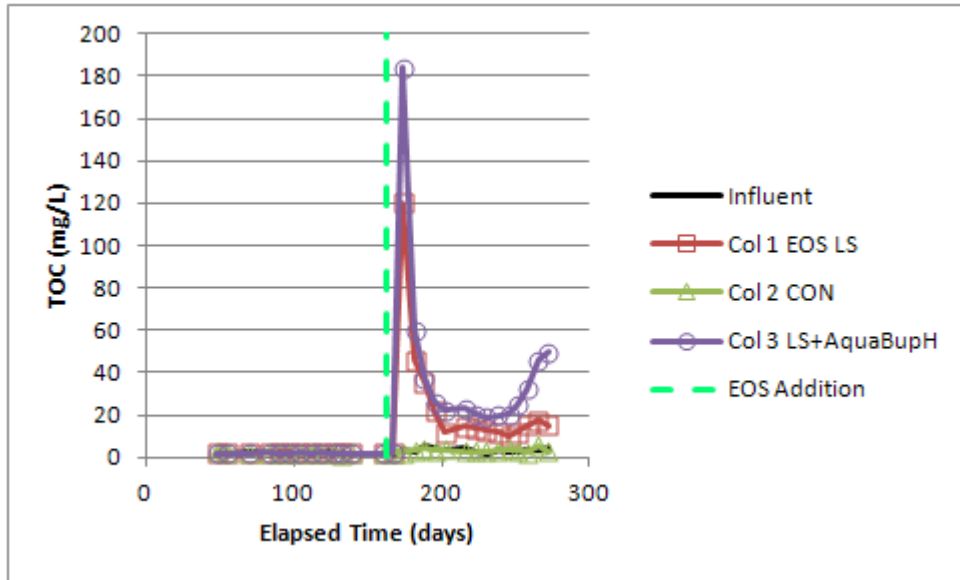

Figure 5.12. Nitrate and sulfate in the influent groundwater and the effluent of the three flow-through columns.

The dashed line indicates the time of emulsified oil addition.

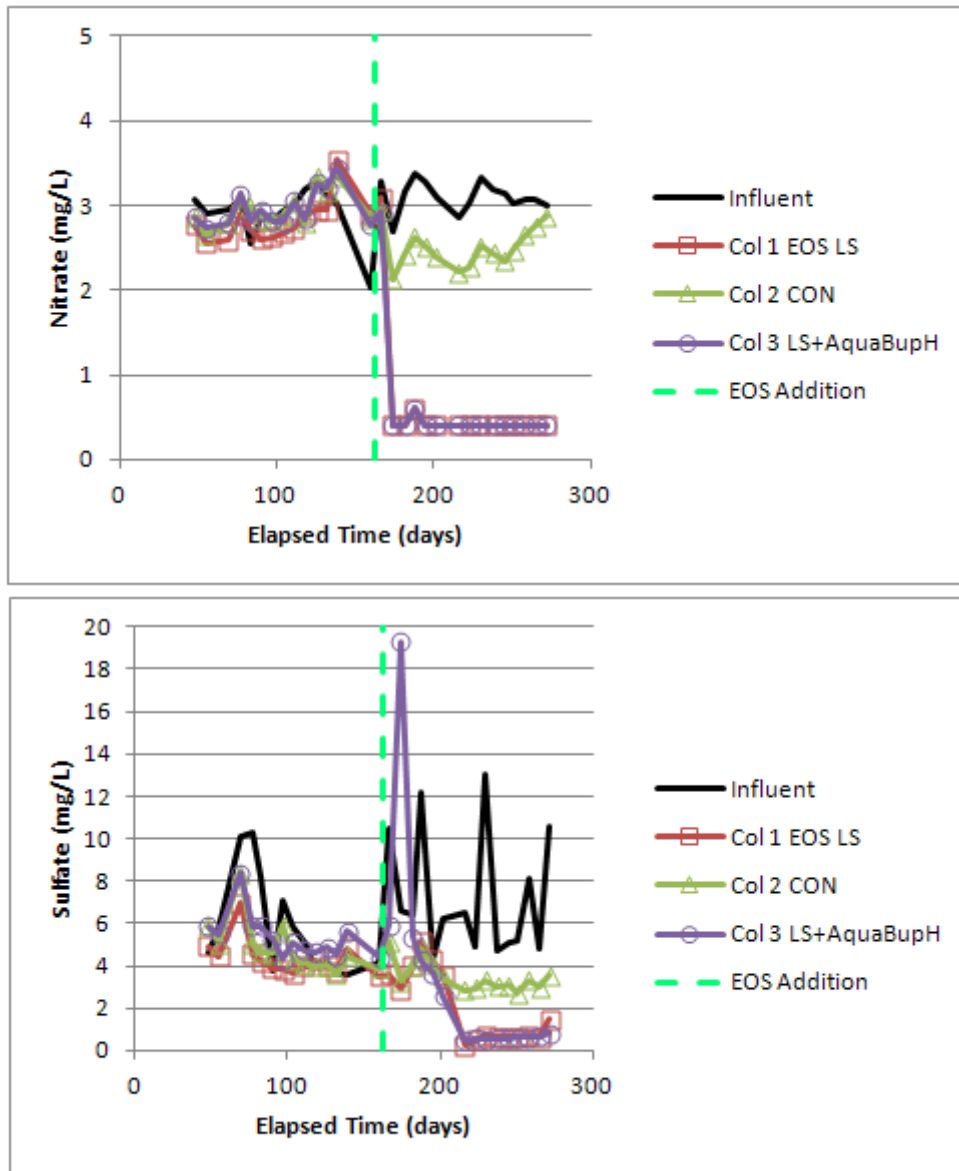

Figure 5.13. Perchlorate in the influent groundwater and the effluent of the three flow-through columns.

The dashed line indicates the time of emulsified oil addition.

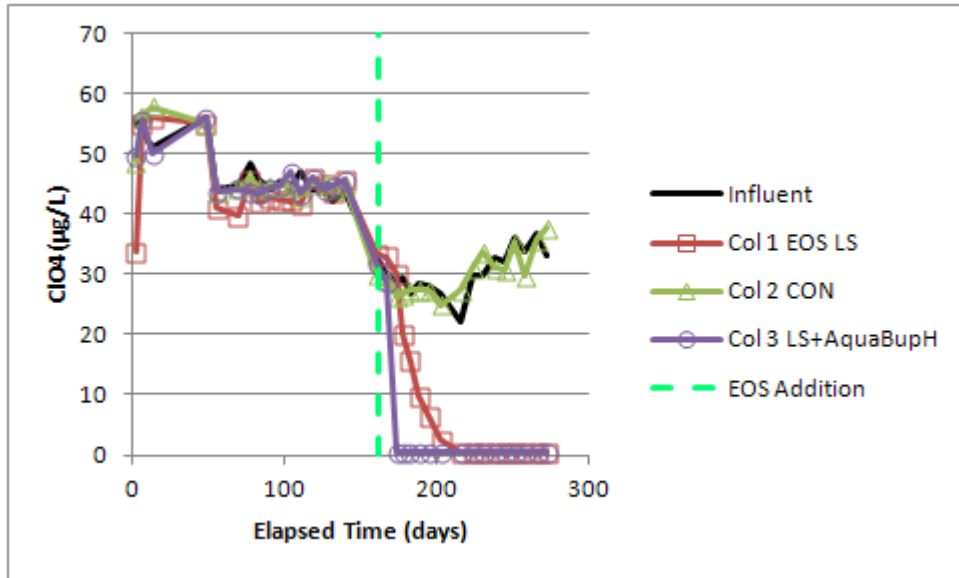

Figure 5.14. HMX in the influent groundwater and the effluent of the three flow-through columns.

The dashed line indicates the time of emulsified oil addition.

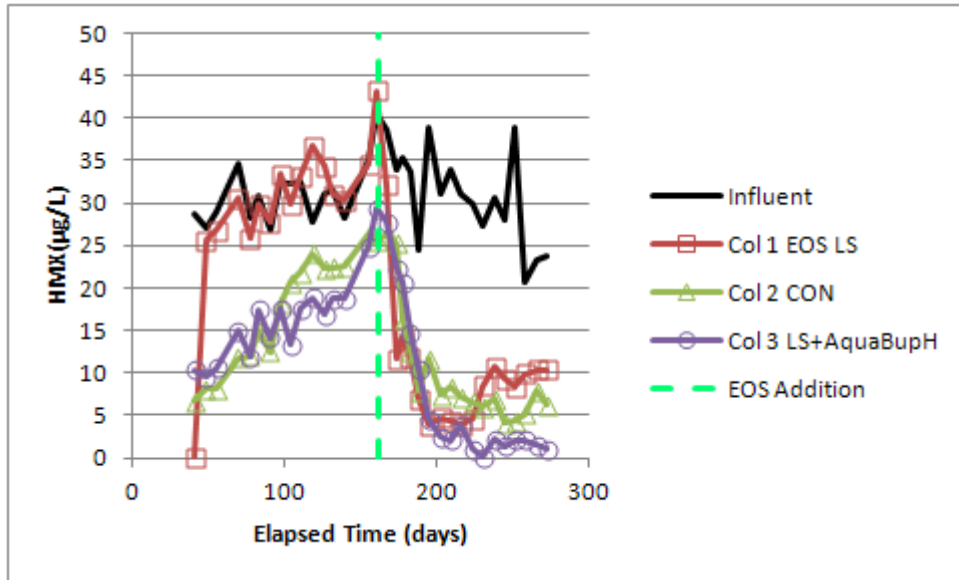

Figure 5.15. RDX in the influent groundwater and the effluent of the three flow-through columns.

The dashed line indicates the time of emulsified oil addition.

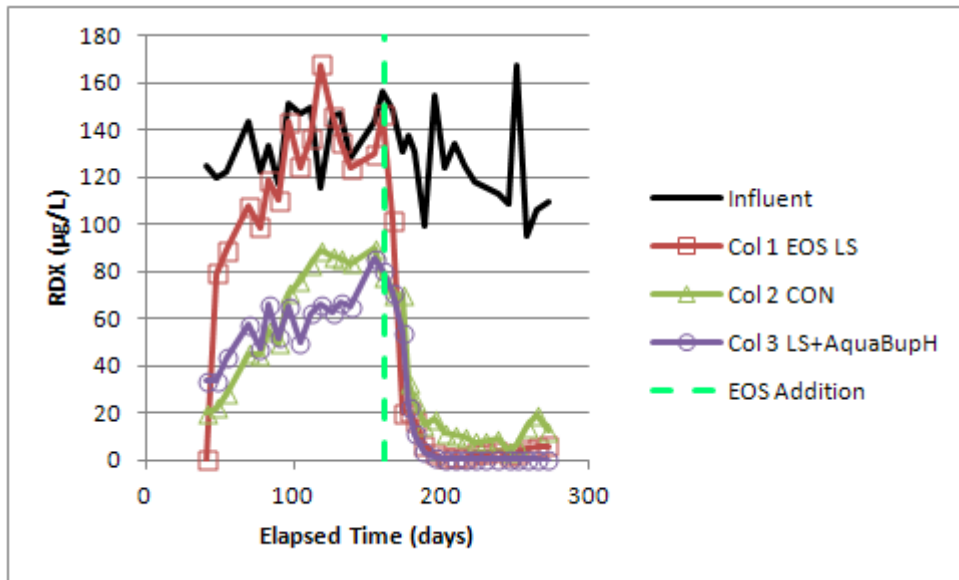

Figure 5.16. MNX, DNX, and TNX in the influent groundwater and the effluent of the three flow-through columns.

The dashed line indicates the time of emulsified oil addition.

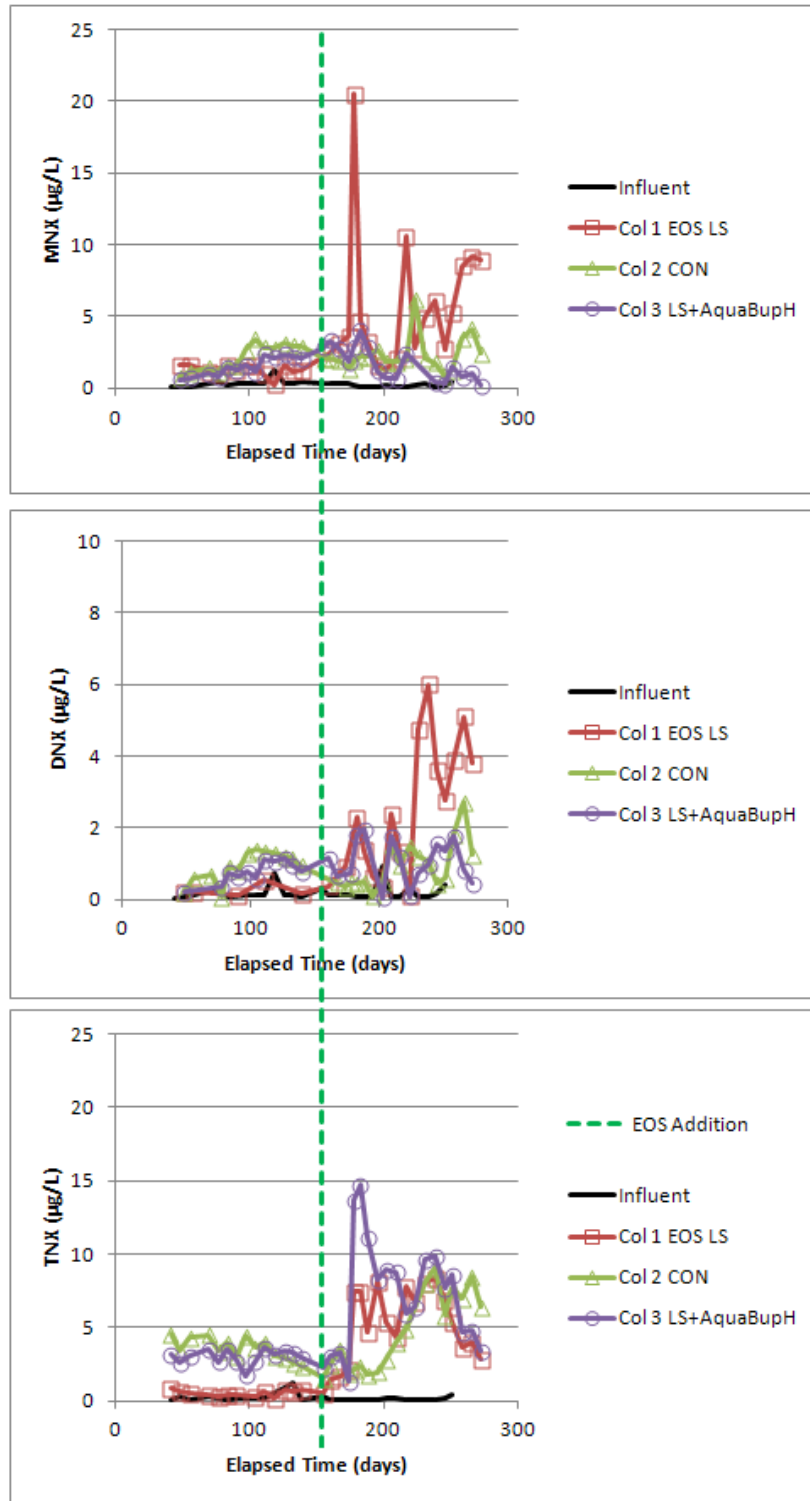

Figure 5.17. Profile of one Geoprobe core from the Dahlgren site showing significant amounts of iron minerals (orange).

The core was from the saturated zone from 7.5 to 10 ft bgs.



Figure 5.18. Profiles of RDX and perchlorate as a function of distance from the influent end of the columns.

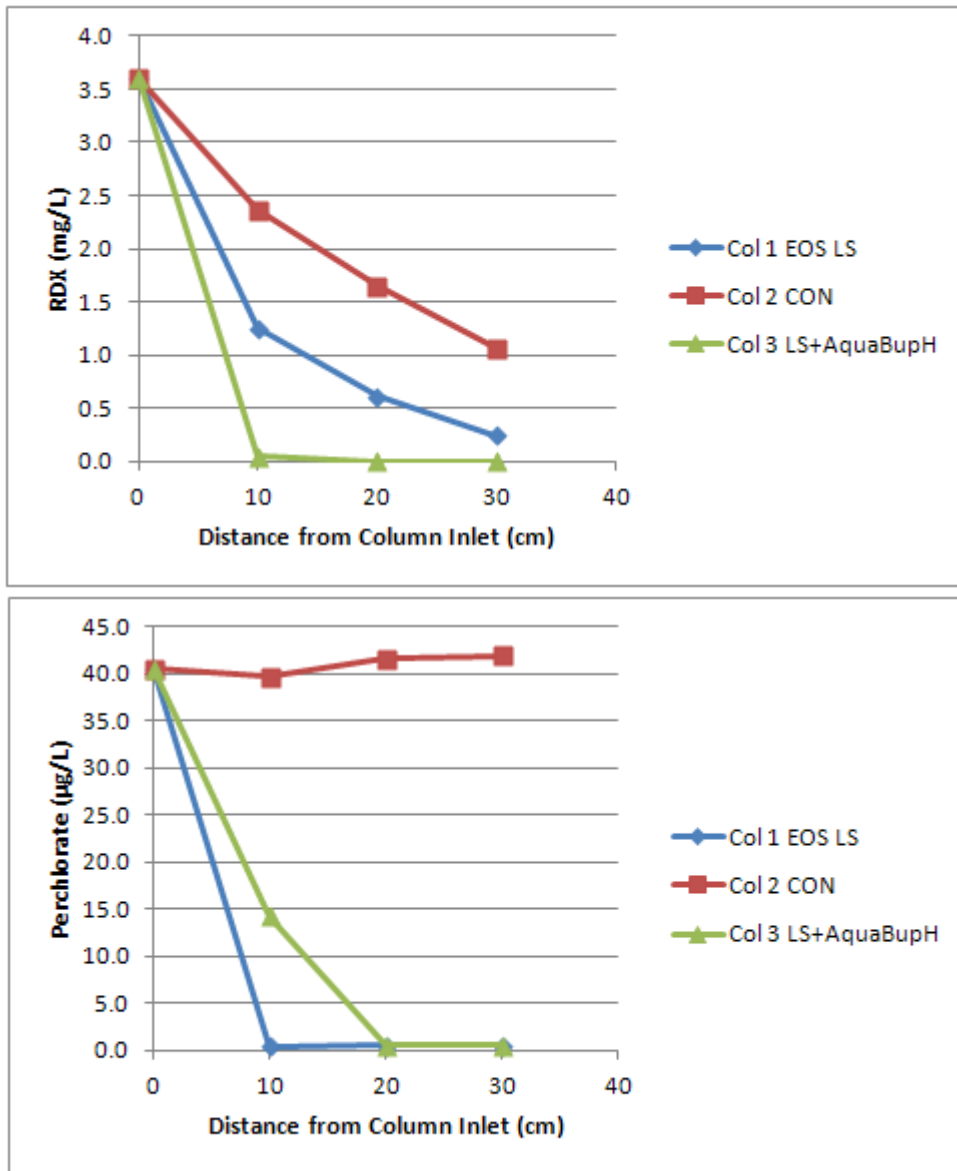
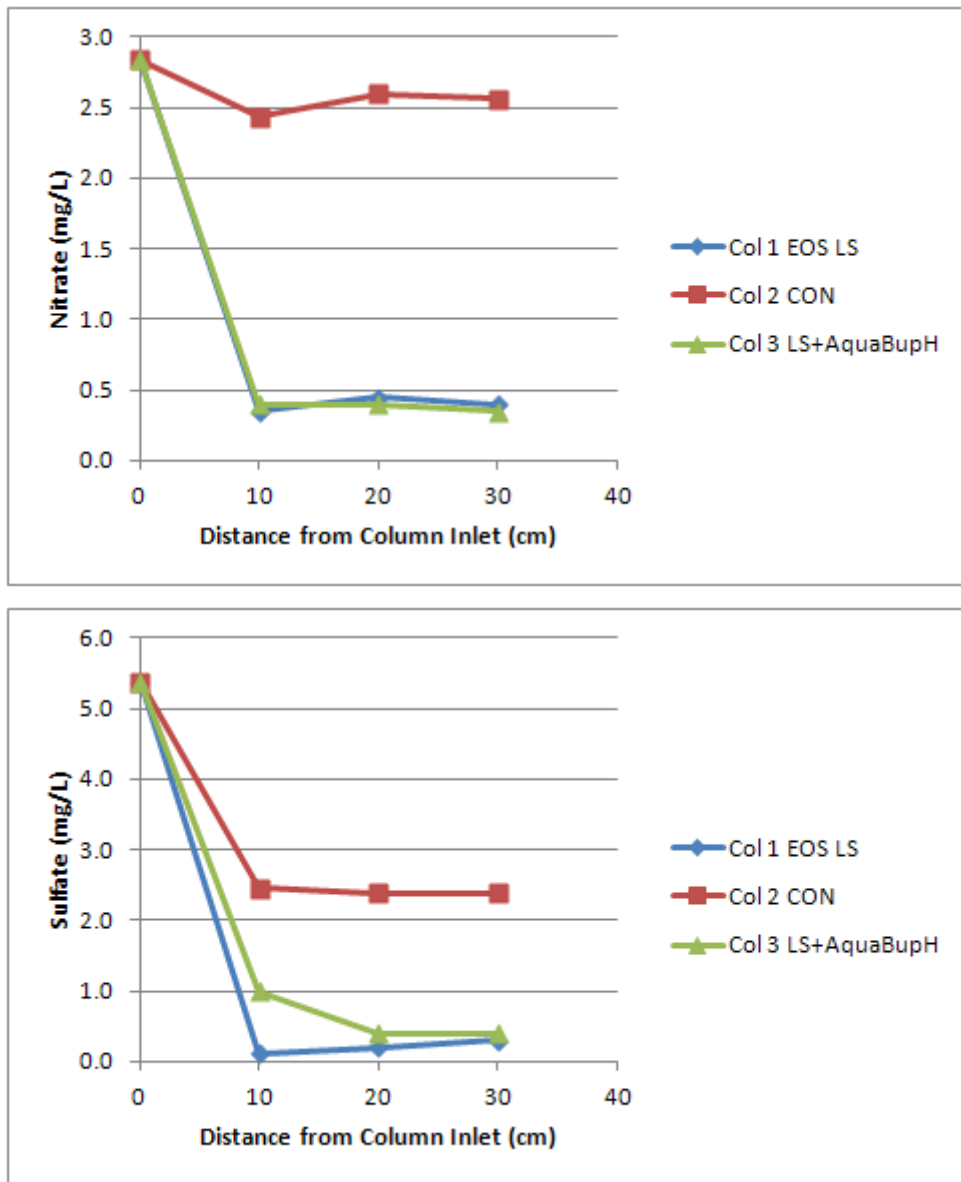

Figure 5.19. Profiles of nitrate and sulfate as a function of distance from the influent end of the columns.



5.2.1.6 Conclusions from the Treatability Studies.

The treatability studies conducted during this project support the application of an emulsified oil biobarrier for in situ treatment of RDX, HMX, and perchlorate in the downgradient plume from the Fast Cook area at Dahlgren. A summary of the treatability study results are as follows:

- Perchlorate, RDX, and HMX were rapidly biodegraded in microcosms receiving emulsified oil (EOS-Low Salt blend) to concentrations <0.5 µg/L for perchlorate and RDX, and <10 µg/L for HMX. No loss of RDX or perchlorate was observed in the unamended microcosms under aerobic or anoxic incubation conditions.
- Perchlorate, RDX and HMX also were biodegraded in aquifer columns receiving two different emulsified oil blends, one of which includes buffering materials (EOS-AquaBupH) to raise pH. Significant loss of RDX also was observed in the unamended control column in this study, which was attributed to a combination of abiotic and biotic processes. It is unclear whether these processes are occurring in the field at some rate (similar losses were not observed in microcosms) or rather are an artifact of the homogenization process used for the column solids (potentially releasing natural organic matter, Fe, or enhancing sorption sites). Based on the extensive and persistent RDX contamination in the EEA area, it is likely that any natural attenuation processes were significantly accelerated in the columns. Unlike RDX, no loss of perchlorate or nitrate was observed in the unamended control column.
- The best oil amendment in the columns based on degradation rates of perchlorate was determined to be a 75:25 (v:v) mixture of EOS Low Salt and EOS AquaBupH. This mixture also maintained the groundwater pH at the desired value of around 6 S.U.
- The emulsified oils generated conditions in the column that caused increases in Fe and Mn, as expected, but only minor mobilization of As (<20 µg/L).
- The emulsified oil retention by the soil was similar to what has been reported for other soils.
- Some interference on the detection of HMX and RDX intermediates by EPA 8330 was apparent in the columns treated with emulsified oil. It is likely that the soybean oil and/or fermentation products from the oil cause this interference. A suitable HPLC method employing a longer mobile phase gradient allowed effective quantification of the explosives compounds of interest (and metabolites) in the presence of interferences from the emulsified oil and its breakdown products.

The conclusions of the treatability study for this project marked a Go/No-Go decision point to move onto the field demonstration phase of the project at the Dahlgren site. Based on the laboratory and field results, all data indicate that an emulsified oil barrier should be an effective technology for in situ degradation of RDX, HMX and perchlorate at the Dahlgren site.

5.2.2 Field Characterization

5.2.2.1 Rationale

In order to properly place the biobarrier for effective treatment of the groundwater, site characterization work was performed during 2010 and 2011 to (1) better define the extent of contamination in the region; and (2) to confirm the local hydrogeology, including lithology, hydraulic conductivity, and the estimated velocity and direction of groundwater flow. These results are described in this section. In addition, a series of treatability studies using sediment and groundwater from the area around CMOBOD02 were performed, including microcosms, flow-through columns, and emulsified oil adsorption tests as detailed previously in Section 5.2.1.

During initial site assessment work on 30 October 2010, four piezometers were installed using a direct-push technology (DPT) rig to gather water chemistry data to determine the local extent of the plume of RDX and perchlorate intersected by monitoring well CMOBOD02. Continuous soil core samples were collected and logged for each of the boring locations (Dahlgren 01 through Dahlgren 04). Upon completion of each of the borings, 1" piezometers were installed in the open boreholes. The piezometers were constructed with Schedule 40 polyvinyl chloride (PVC), with 10 feet of 0.010" slot screen encompassing the majority of the water bearing layer. Filter pack was installed to approximately 2 ft above the screened interval, and the remainder of the borehole was sealed with bentonite chips (hydrated) to the ground surface. The locations of these borings and piezometers are provided in **Figure 5.1** (borings became piezometers Dahlgren 01-04) and **Figure 5.20**.

An additional investigation was performed on 23 and 24 May 2011 based on the results from 30 October. The purpose of this investigation was to confirm the previously reported groundwater potentiometric surface (and likely flow direction) (**Figure 4.8**), and to determine the approximate extent of groundwater contamination in the vicinity of monitoring well CMOBOD02. This contamination is presumed to originate from the Fast Cookoff Area (**Figure 4.9**). Fourteen (14) soil boring locations were selected east of the Fast Cookoff area, in and around a surficial swale feature that appeared to be directly affecting the groundwater flow direction and energetics plume migration at the site. Continuous soil cores were collected through the first encountered water bearing layer to the confining clay unit using DPT. Upon the completion of the soil borings and review of the boring logs, 1" piezometers were installed at each location. The piezometers were constructed to encompass the full depth of the groundwater column (groundwater was generally encountered between 1.5 and 5.8 ft bgs) down to an impermeable clay layer, which generally occurs from ~ 6 to 15 ft bgs (average of 9 ft bgs). The piezometers were constructed with schedule 40 PVC, with 5 ft or 10 ft of 0.010" slotted screen, depending on the lithology of the borehole. Core logs and piezometer completion details are provided in Appendix A. Filter pack was installed to approximately 1.5 to 2 feet above the screened interval, and the remainder of the borehole was sealed with bentonite chips (hydrated) to the surface. The piezometers were purged for approximately 10 to 30 minutes after completion to remove the majority of fine sediment suspended in the groundwater due to drilling disturbances. The piezometers were surveyed and site-wide groundwater levels and groundwater chemistry parameters (e.g. DO, pH, etc.) were measured at the end of the investigation. Groundwater samples were collected from the piezometers and analyzed for perchlorate, explosives, and additional groundwater chemistry

parameters (e.g. anions, TOC, etc.) at CB&I's New Jersey Department of Environmental Protection (NJDEP) certified laboratory in Lawrenceville, NJ.

Due to discrepancies discovered in the contaminant plumes, along with the need to further our understanding of the groundwater flow regime in the area east of the Fast Cookoff area, an additional subsurface investigation was performed beginning on 19 October 2011. The focus of this investigation was the area south of the OB/OD area, where the majority of the groundwater plume was detected during the previous sampling events (see Section 5.2.2.4). Ten additional piezometers were installed following the same construction criteria used during the May 2011 investigation. These piezometers were similarly installed with the screened portion of the piezometer contained within the upper water bearing unit overlying the clay. The piezometers were pumped continuously for approximately 10 to 30 minutes to remove any suspended sediments in the groundwater prior to sample collection. Site-wide groundwater levels were collected at the end of the investigation.

At the conclusion of the investigation work, a total of 28 1" piezometers were installed, as shown in **Figure 5.20**. Soil boring and piezometer construction logs can be found in **Appendix A**. A description of the local geology is provided in the next section.

5.2.2.2 Test Site Geology

Continuous soil core samples were collected in 4-foot intervals using a DPT rig at each piezometer location. The collected soil cores were logged by a CB&I geologist and used to determine the construction and placement of the piezometers. The soil collected within the cores was visually classified using the Unified Soil Classification System (USCS). As depicted in **Appendix A**, the soil borings typically revealed a surficial 0.5 to 3 ft layer of dark silt or lean clay. This material overlaid a poorly-graded sand interbedded with clayey sand and lean clay lenses, consistent with the Columbia Aquifer sediments. Beneath the poorly-graded sand, an impermeable fat clay layer approximately 2 to 8 feet in thickness was present overlying the marine, glauconitic sand of the Nanjemoy-Marlboro confining unit, marking the end of the boring.

Based on the analysis of recovered soil, the average site-wide thickness of the interbedded, water conductive layers is 5.9 ft with approximately 4.7 ft of the layer consisting primarily of sandy material. On average, the conductive layer begins at approximately 3.1 ft bgs and ends at approximately 9.0 ft bgs, below which the impermeable fat clay and marine glauconitic sand exist. It should be noted that the regional geology is highly variable in grain size as well as layer thickness due to the nature of fluvial-estuarine deposits. A typical stratigraphic diagram of the subsurface geology located within the primary area of interest, the immediate area surrounding monitoring well CMOBOD02, is displayed in **Figure 5.21**.

Groundwater was typically encountered between 1.5 and 5.8 ft bgs during the May 2011 groundwater survey, and 0.5 to 3.8 ft bgs in October 2011. The average depth to groundwater across the Churchill Range was 3.8 ft bgs in May 2011 and 2.1 ft bgs in October 2011 indicating a seasonal fluctuation of approximately 1.5 to 2 ft. It should be noted that the October site characterization event occurred following an exceptionally wet fall season (including passage of Hurricane Irene and Tropical Storm Lee), which caused widespread inundation of the Churchill Range site. Groundwater measurements compiled during the two characterization events were

used to create potentiometric surface maps (**Figure 5.22** and **Figure 5.23**, respectively). The figures confirm previous site data which identifies a general groundwater gradient to the south-southeast. Groundwater measurements data from May 2011 and October of 2011 are presented in **Appendix B**.

5.2.2.3 Groundwater Chemistry

In November 2008, we sampled several wells on the Churchill Range to conduct studies for SERDP Project ER-1607. Basic geochemistry was collected for wells GWOBOD02, GWOBOD03, CMOBOD02, and EEA-S17 (as an uncontaminated control well), along with analysis of metals, explosives, anions and cations. The basic geochemical parameters for these Churchill Range wells in 2008 are provided in **Table 5.8**. During the 2010 and 2011 sampling events, pH and dissolved oxygen measurements were collected from each of the piezometers prior to collecting groundwater samples using a field meter and in-line flow cell. These measurements were used to create maps depicting geochemical conditions at the Churchill Range. The pH measurements east of the Fast Cookoff area ranged from 3.9 to 6.4, averaging approximately 4.9. Dissolved oxygen measurements ranged from 0 to 9.6 mg/L, averaging approximately 5.3 mg/L. Maps showing the most current (October, 2011) pH and dissolved oxygen concentrations are presented in **Figure 5.24** and **Figure 5.25**, respectively.

Table 5.8. Water quality data from four permanent wells on the Churchill Range.

Well ID	<i>Parameter</i>						
	pH (SU)	ORP (mV)	DO (mg/L)	Sp. Cond. (µS/cm)	Cl ⁻ (mg/L)	NO ₃ ⁻ (mg/L)	SO ₄ ⁻ (mg/L)
GWOBOD02	4.20	289	1.5	0.079	8.4	1.2	9.5
GWOBOD03	4.45	236	3.7	0.073	6.7	0.9	6.4
CMOBOD02	4.76	424	4.1	0.052	3.8	<0.1	4.3
EEA-S17	4.02	293	1.9	0.039	2.2	0.3	8.5

5.2.2.4 Test Site Groundwater Flow and Direction.

Based on the proximity of the Potomac River, an In-Situ Level Troll 700 pressure transducer was placed in CMOBOD02 to record pressure fluctuations. The transducer was installed to determine the impact on the Churchill Range of tidal influences. The transducer was programmed to record a pressure reading once an hour for a period of 10 days. Upon the completion of the 10 days, the transducer data was downloaded and analyzed for tidal fluctuations. The overall trend for the transducer data was a gradual downward drop in the groundwater elevation of approximately 0.6 ft. Minor fluctuations (on the order of 1/100 of a foot) were observed in the groundwater data indicating a slight tidal influence, however, not on a scale that would significantly disrupt the groundwater flow direction. Data from the pressure transducer are located in **Appendix C**.

During the May 2011 event, an In-Situ Level Troll 700 was placed in monitoring well CMOBOD02 to record the draw down and recharge of the groundwater during sample collection. The transducer data was recorded with the intention of calculating an estimation of the K value within the surrounding material through the use of the recharge data. Data was recorded throughout the pumping at 5 second intervals.

In addition to the pump test date, slug testing was performed on monitoring well CMOBOD02 during the October 2011 site investigation to determine the localized K value. The slug testing was performed using a volume-displacement method. The slug used in the testing was a 1.76 ft long x 0.29 ft diameter weighted slug of a known volume that was lowered into the well using a small diameter, high strength fishing line. The cylinder was rapidly lowered into the well, causing a temporary rise in the water level. Manual data measurements were used to record the water levels as the groundwater returned to equilibrium. Instantaneous water levels were recorded at intervals that varied from every 15 to 30 seconds. The slug test was repeated three times to ensure the accuracy of the data.

The slug test and pumping test data were analyzed by the Bouwer and Rice method (Bouwer, 1989; Bouwer and Rice, 1976) based on the unconfined nature of the Columbia aquifer and the partial penetration of the monitoring well. Well construction, pump test, and slug test data were inserted into a USGS spreadsheet (USGS, 2010) designed to calculate K values from the acquired slug test data.

The pump test recharge data collected in May of 2011 at CMOBOD02, the nearest permanent well to the proposed location of biobarrier installation, revealed a K value of approximately 4.3 ft/day. The slug testing performed by CB&I in October of 2011 on CMOBOD02 revealed a K value averaging approximately 4.4 ft/day.

Groundwater flow velocity was calculated using a standard groundwater flow equation (Fetter, 1988):

$$V = \frac{Ki}{n_e} \quad (1)$$

V = groundwater velocity

K = hydraulic conductivity

i = gradient

n_e = porosity

Using an estimated aquifer porosity of 0.30, calculated K values of 4.3 to 4.4 ft/day, and a localized hydraulic gradient of 0.004 over the 900 foot study area for the potential biobarrier, the expected horizontal flow velocity in this area is approximately 0.059 ft/day or 21.4 ft/year. The K value and horizontal flow rate calculated based on the slug test data falls within the ranges reported in previous groundwater reports for the area (URS, 2010; Bell, 1996). The USGS calculation sheets and pump/slug test data are located in **Appendix C**. The direction of groundwater flow is estimated to be to the south-southeast, based on measured hydraulic gradients and observed contaminant distributions.

Figure 5.20. Map showing the well and piezometer locations on the Churchill Range of NSWC Dahlgren (November 2011).

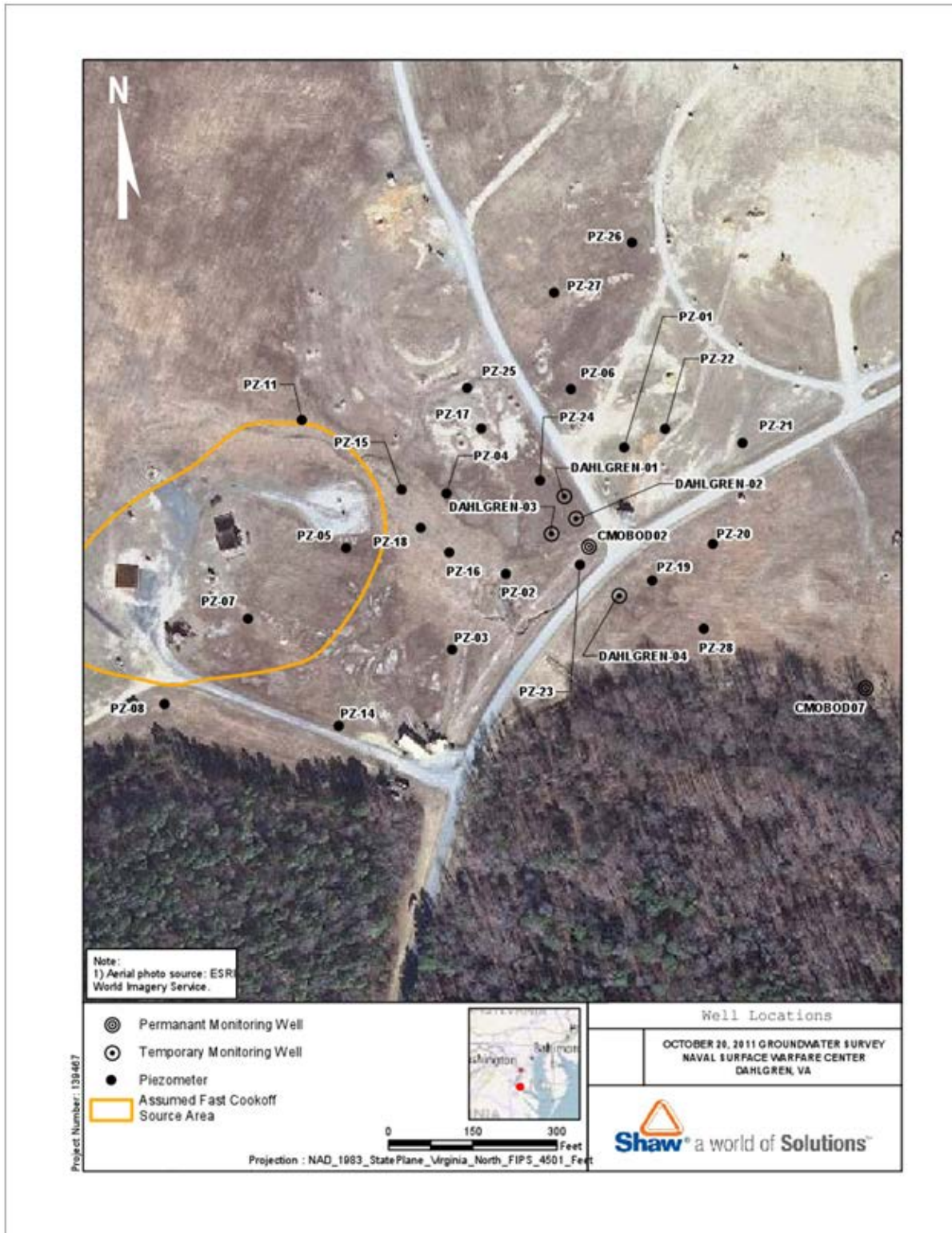

Figure 5.21. Stratigraphic diagram of the area surrounding monitoring well CMOBOD02.

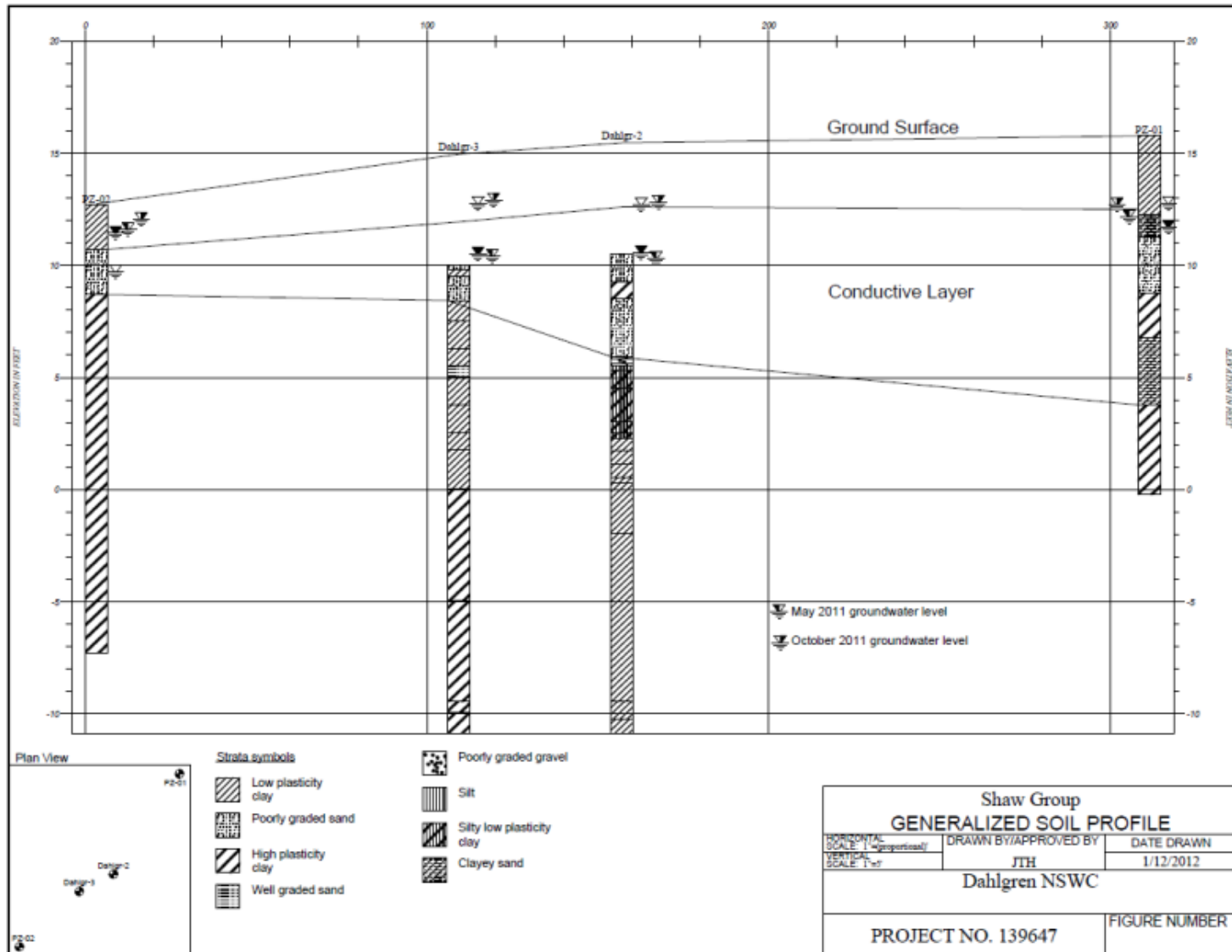

Figure 5.22. Potentiometric surface map of the Churchill Range in May 2011.

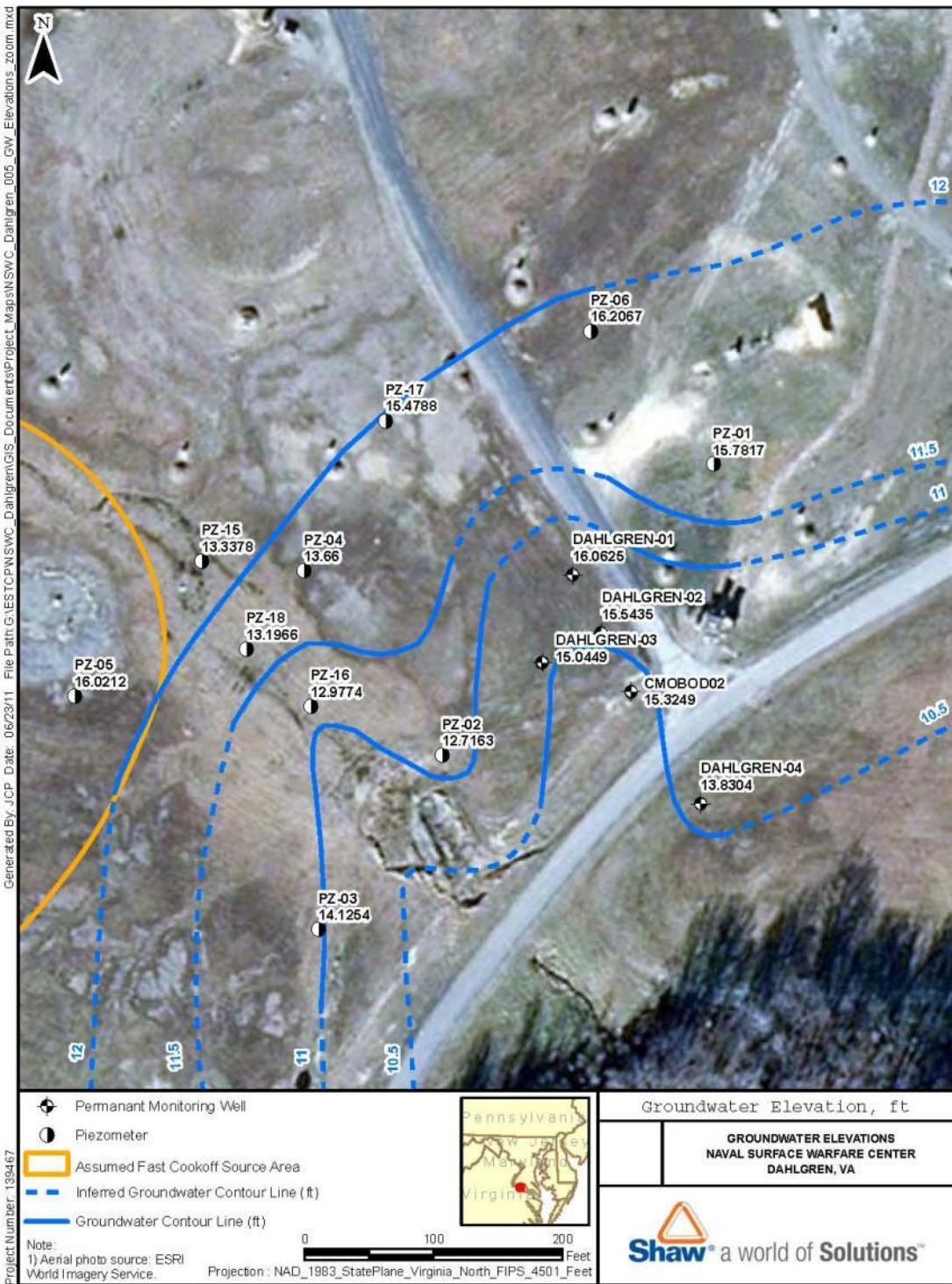

Figure 5.23. Potentiometric surface map of the Churchill Range in October 2011.

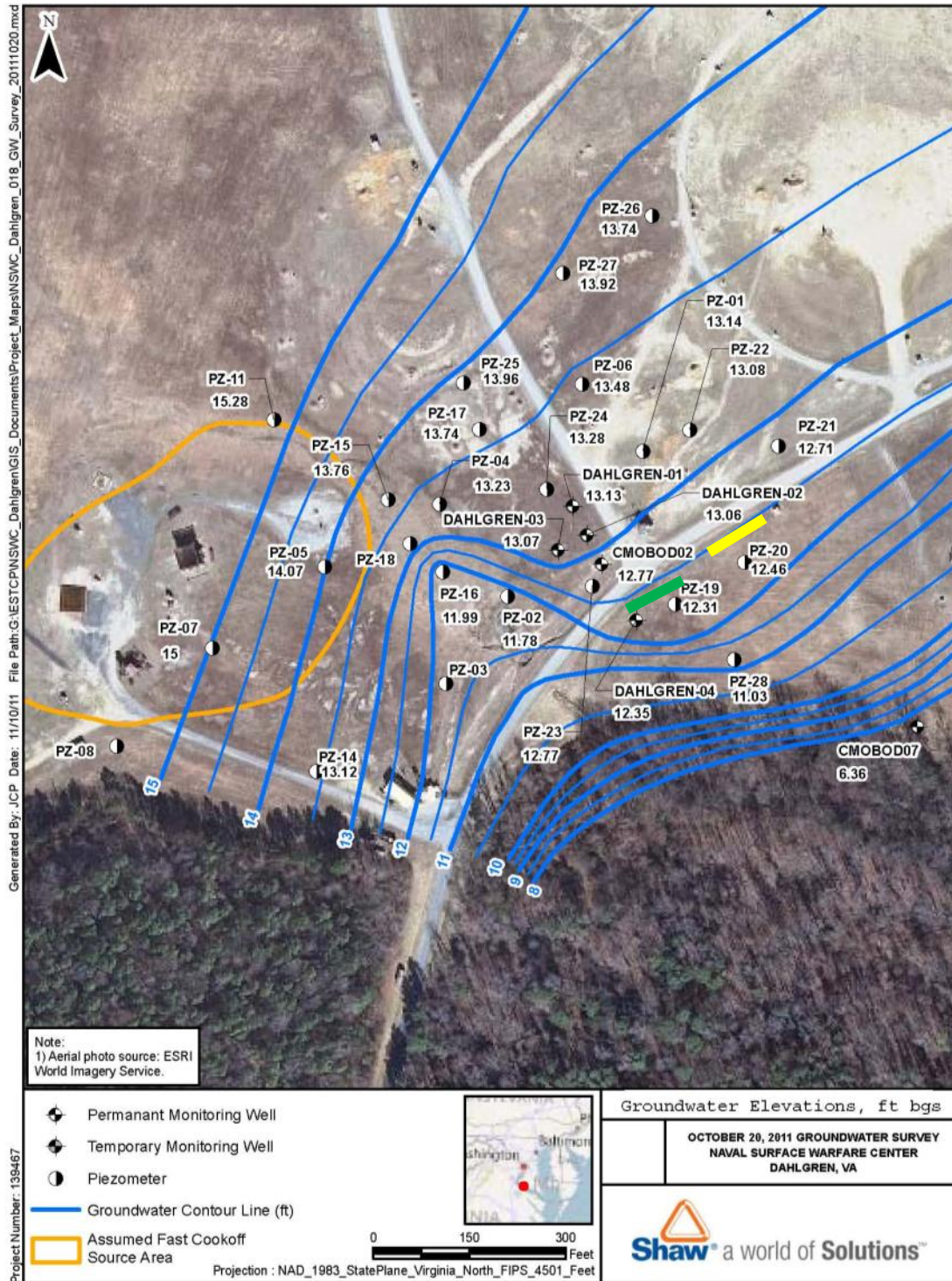
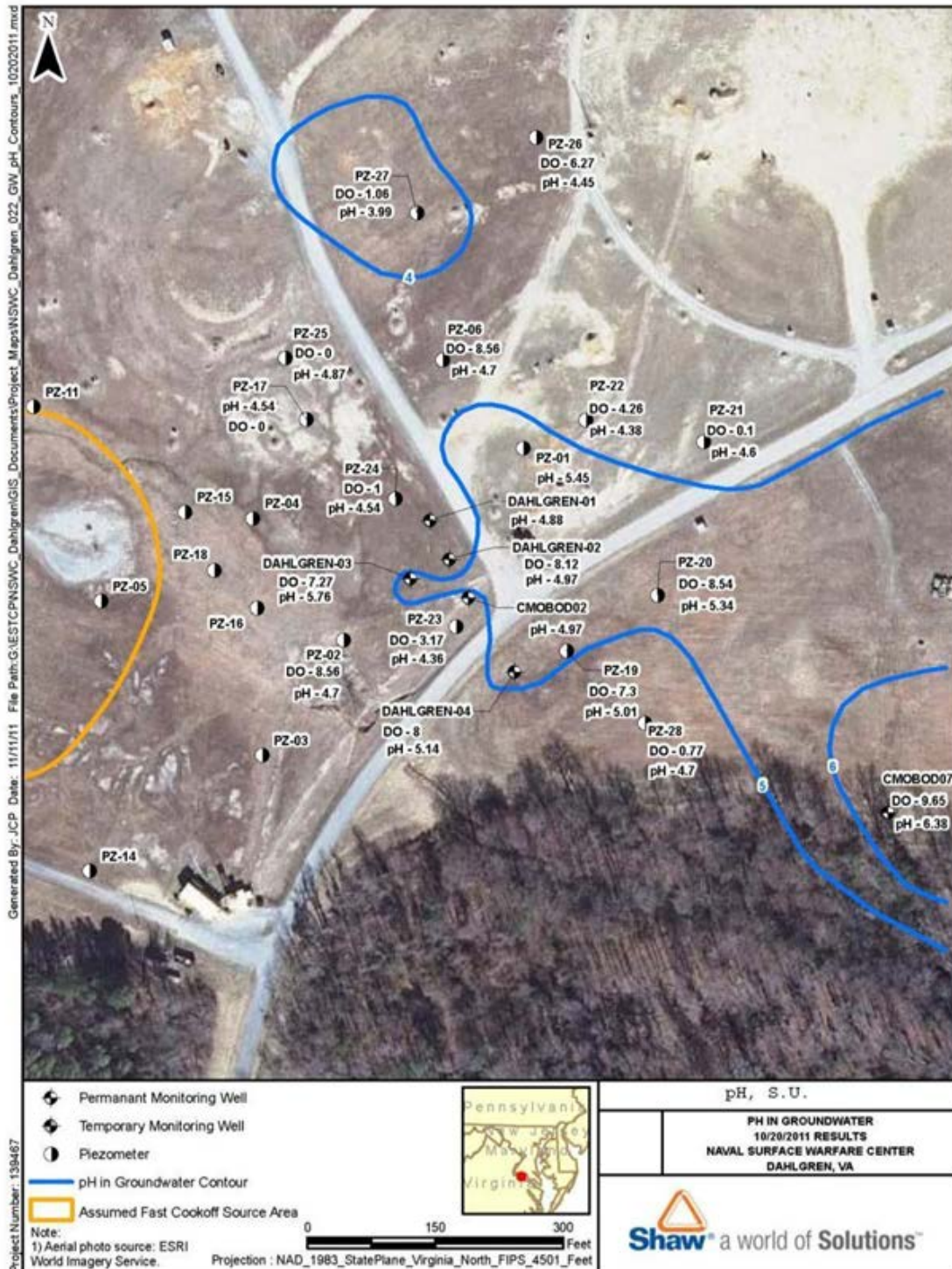

Figure 5.24. Dissolved oxygen contours in the southeast area of the Churchill Range.



Figure 5.25. pH contours in the southeast area of the Churchill Range.



5.2.2.5 Explosives and Perchlorate in Test Site Groundwater

Groundwater samples were collected for analysis of explosives by EPA Method 8330 and perchlorate by EPA Method 314.0 during all three site characterization events. Data from the first sampling event in which wells Dahlgren 01 to Dahlgren 04 were installed are provided in **Figure 5.1**. (Locations L1-L4 in Figure 5.1 became wells Dahlgren 01-04.). During the second site characterization event in May 2011, piezometers PZ-01 to PZ-07, PZ-11, and PZ-14 to PZ-18 were installed (13 total piezometers) and sampled. The primary focus of this site characterization event was the area to the southeast of the Fast Cookoff region and to the northeast of CMOBOD02, although some piezometers also were installed to the north and south of this region. The data collected for perchlorate, RDX and HMX from this event are provided in **Figure 5.26**. The regions to the north (PZ-11) and directly to the east (PZ-15, PZ-04, PZ-18, PZ-16) of the Fast Cookoff generally had levels of RDX, HMX and perchlorate that were below detection (10 µg/L for HMX and RDX, and 0.5 µg/L for perchlorate). RDX (but no HMX, and only a trace of perchlorate) was detected just south of the Fast Cookoff Area in PZ-07 and a low concentration of HMX (but no RDX or perchlorate) was detected further south in PZ-14. The most significant and consistent concentrations of each target compound in groundwater were found further east (PZ-01, PZ-02, PZ-03, Dahlgren 01-04) and even slightly northeast of the Fast Cookoff Area (PZ-06).

The general absence of perchlorate and explosives directly east of the Fast Cookoff Area is inconsistent with this region being the primary source of these contaminants in the vicinity of well CMOBOD02 as originally hypothesized, particularly considering the general direction of the groundwater gradient in this region to the east-southeast (**Figure 4.8** and **Figure 5.23**). Rather, the data suggest that there are one or more source areas to the north of CMOBOD02, and that contamination may extend further east than originally thought. As a result of the data collected in May 2011, a third site assessment event was conducted in October 2011 to determine contaminant concentrations in groundwater further north, south and east of CMOBOD02. During this event, an additional 10 piezometers were installed (PZ-19 through PZ-28), and groundwater samples were collected from these wells. A number of the existing piezometers and wells were also sampled during this phase. The piezometers present near the Fast Cookoff area that had low or non-detect concentrations in May 2011 were not sampled during October 2011 due to limited available time on the range.

The data from the October, 2011 sampling event were compiled and contour maps of RDX (**Figure 5.27**), perchlorate (**Figure 5.28**), and HMX (**Figure 5.29**) were prepared based on the data. The data indicate that the majority of the contamination in groundwater flowing towards the Black Marsh originates from multiple point sources to the east of the Fast Cookoff Area and to the south and west of the central “arena”. The contour maps drawn in the previous figures are our best current interpretation of the data. Based upon all available data, we have selected two possible locations for the installation of the biobarrier, a primary location and a back-up location. Details are provided in Section 5.2.3.

5.2.3 Selection of Biobarrier Location

Based on historical data, the new characterization data, and ongoing activities and structures at the Churchill Range, the first choice for the placement of the biobarrier was on the southeast side of the main access road in the vicinity of PZ-20. This location is shown as a yellow line in **Figures 5.27** to **5.29**. This proposed barrier location intercepted perchlorate, RDX and HMX from an

apparent source zone. The expected concentrations in the barrier area were $>60 \mu\text{g/L}$ for RDX, $>100 \mu\text{g/L}$ for perchlorate and $>25 \mu\text{g/L}$ for HMX. The direction of groundwater flow in this region was also clearly to the southeast (**Figure 5.23**). The barrier length indicated is ~ 100 ft as discussed in detail in Section 5.3. The one potential issue with this location was the fact that the underlying clay layer was detected at only 6.5 ft bgs in the core log for PZ-20, the only piezometer installed in the immediate vicinity. Conductive materials were present above this depth and PZ-20 produced ample water for low-flow sampling. However, it is possible, even likely, that the water table could decline to below 6.5 ft bgs in the summer if drought conditions occur. For a full-scale barrier application, this would not be a significant issue, as no contaminants would move through this area when the water table is low. However, for the demonstration, sampling would have to have been interrupted during this time if one or more wells were dry.

The second selected location for the demonstration was ~ 120 ft to the southwest in the vicinity of PZ-19 and Dahlgren 04. This location is shown as a green line in **Figures 5.27 to 5.29**. This alternative barrier location also intercepted an apparent plume with perchlorate and RDX, although perchlorate concentrations were lower than in the previous area. The expected concentrations in the barrier area were $>40 \mu\text{g/L}$ for RDX (perhaps as high as $100 \mu\text{g/L}$) and $>20 \mu\text{g/L}$ for perchlorate. HMX was also expected to be present in this area at concentrations ranging from ~ 7 to $25 \mu\text{g/L}$. The direction of groundwater flow in the region of the barrier appeared to be shifting to the south compared to the previous location (**Figure 5.23**), and limited data from May, 2011, showed potential flow to the southwest toward the swale area (**Figure 5.22**). The core logs from PZ-19 and Dahlgren 04 suggested that the confining clay layer in this region occurred at 10 to 12 ft bgs, with mixed conductive materials and clay zones above (**Appendix A**). Thus, this region appeared to provide a slightly greater conductive zone based on available data. After careful consideration, this location (green line) was chosen to locate the barrier rather than the initial site (yellow line), based primarily on the depth to the lower clay layer and the potential for dry wells during the summer months.

Figure 5.26. RDX, HMX and perchlorate data from piezometers installed during the May 2011 site investigation.



Figure 5.27. Plume map for RDX in the southeast area of the Churchill Range.



Figure 5.28. Plume map for perchlorate in the southeast area of the Churchill Range.

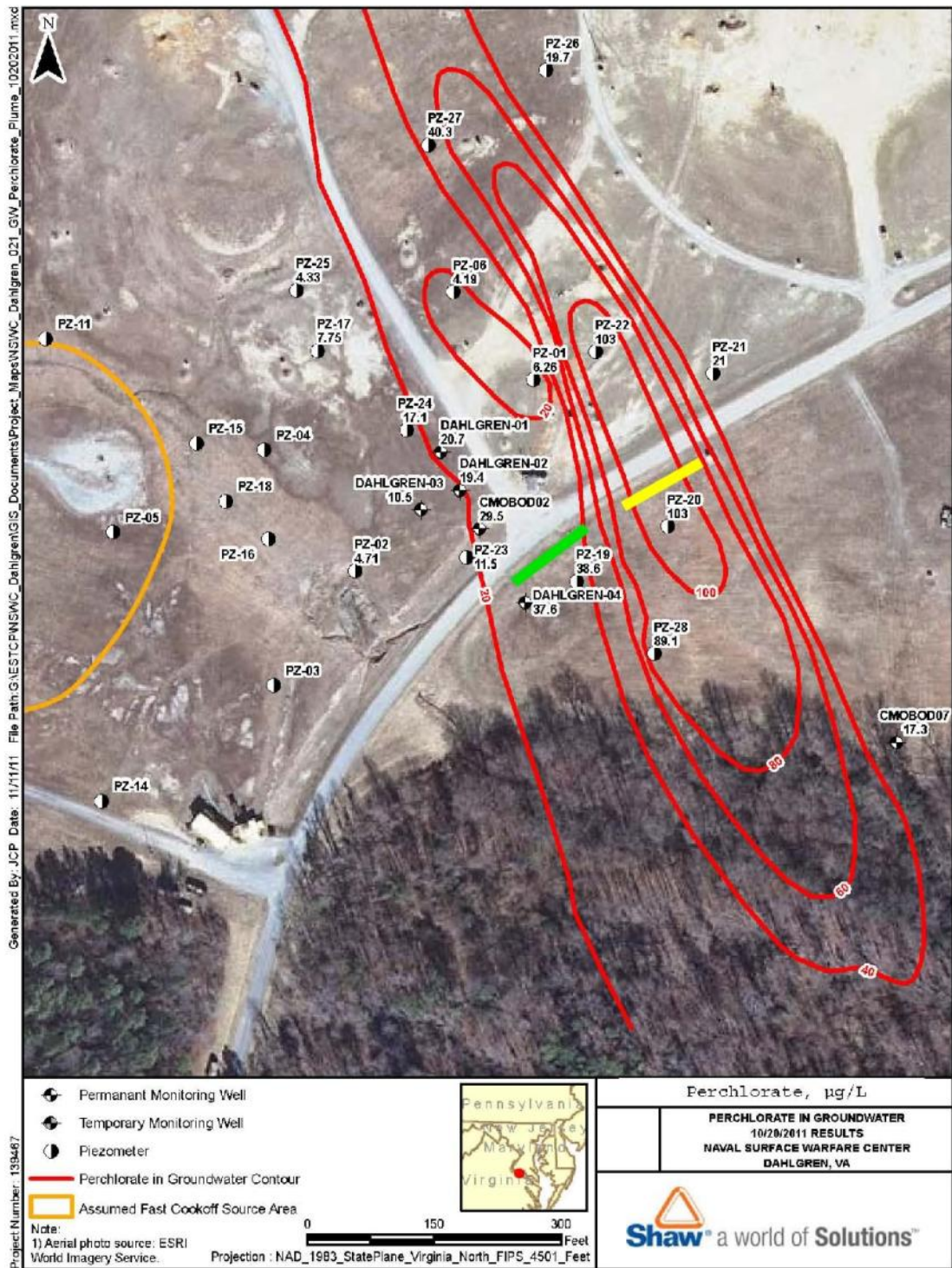

Figure 5.29. Plume map for HMX in the southeast area of the Churchill Range.



5.3 DESIGN AND LAYOUT OF FIELD DEMONSTRATION COMPONENTS

During this project, an emulsified oil substrate was injected into the subsurface to form a passive biobarrier. The effectiveness of the barrier for reducing migration of perchlorate and explosives in groundwater at the EEA was determined using a series of groundwater monitoring wells. The biobarrier was installed cross-gradient to groundwater flow. Samples were collected twice prior to biobarrier installation (10 February 2013), and then for a period of 30 months after installation. Upgradient and downgradient groundwater was monitored for perchlorate, RDX, HMX and other explosives, field parameters, total organic carbon (TOC; as a measure of oil concentration), fatty acids, dissolved metals, anions, and field parameters. Precipitation data was obtained from site personnel for the period covering 20 months (October 2013 to June 2015). The details of the field plot design are provided below, and a schematic of the plot is given in **Figure 5.31**.

5.3.1 Demonstration Layout

5.3.2.1 Biobarrier Design

The “Emulsified Oil Design Tool” prepared by Dr. Robert Borden at North Carolina State University was used to determine injection point spacing, oil volume, and the influence of a number of site variables and injection options on injection cost. Design parameters and output from the design tool are presented in **Appendix D**. A summary of the design parameters are presented in **Figure 5.30**.

5.3.2.2 Biobarrier Injection Well and Monitoring Well Installation

The proposed primary and secondary locations of the biobarrier were discussed previously in Section 5.2.3 and are provided in **Figures 5.23, 5.27, 5.28** and **5.29** to show how the barrier was designed to intercepted plumes of the target contaminants. After additional on-site assessment, the final installation of the biobarrier was performed at the location designated by the “green bar” in **Figure 5.29**. Details of the selection process are provided in Section 5.2.3.

A diagram of the final demonstration plot is presented in **Figure 5.31**. The demonstration plot consisted of 20 emulsified oil injection wells spaced in a single row on five foot centers, three of which served as in-barrier monitoring wells after oil injection. The main monitoring well network consisted of one upgradient monitoring well and six downgradient monitoring wells, spaced from -10 ft to +40 ft along the centerline of the expected groundwater flow through the biobarrier. An additional seven monitoring wells were spaced on either side of the centerline within and on the edge of the expected zone of influence of the injected oil. Existing well CMOBODO2, which was ~ 50 ft upgradient of the biobarrier, was also sampled during the course of the demonstration. This well (4” diameter) was the only well that was not installed for the demonstration.

All of the wells were 1-inch inner diameter (ID) schedule 40 PVC, and were installed using direct push (DPT) after EOD clearance to 2 feet. The total depth of each well was ~ 8 to 12 ft. bgs, based on the local geology of the demonstration plot area. An impermeable lean clay was generally encountered at these depths, and that clay served as the bottom of the treatment plot wells (see previous discussion of depth in Section 2.5.3). There was a relatively narrow saturated zone in the demonstration area (approximately 4 ft to 8 ft bgs depending on season and rainfall). As a result, each of the oil injection and monitoring wells were screened over a 5 ft interval and just into the

lean clay layer (e.g., 5 to 10 ft bgs for a well where the clay was encountered at ~ 10 ft) within the saturated zone using 0.010" slotted screen PVC.

After well insertion, filter pack was installed to approximately 1 foot above the screened interval, and the remainder of the borehole was sealed with bentonite chips (hydrated) to approximately 9 inches bgs. The hydrated bentonite was used to provide a good seal to the surface through the unsaturated zone, which is critical during oil injection under pressure (<5 psi) to prevent daylighting

Each well was finished with a plastic flush mount vault (installed to approximately 9 inches bgs) to allow for cutting of the grass in the demonstration area. Each well was purged for approximately 30 minutes after completion to remove the majority of fine sediment suspended in the groundwater due to drilling disturbances.

5.3.2.3 Baseline Sampling

After the wells were installed, two rounds of baseline sampling were performed (see Section 5.4 below for sampling and analysis details).

5.3.2.4 Biobarrier Installation

At the conclusion of the baseline sampling, the emulsified oil was injected. Injection records for each of the 20 injection wells are presented in **Table 5.9**. The oil mixture utilized was a 4% (v:v) solution of EOS 550LS ("low salt") dissolved in site groundwater (primarily from CMOBOD02) and amended with 0.75% (v:v) EOS CoBupH, a slow-release magnesium hydroxide colloidal solid. The CoBupH product was developed by the manufacturer after our initial laboratory treatability testing and was substituted for the AquaBupH used in the laboratory studies, which also contained emulsified oil. The groundwater and amendments were mixed in 3 separated batches in a 600-gallon poly tank. Each batch of injection solution was continually mixed with a submersible pump to keep the CoBupH particles in solution.

A centrifugal pump was used to pump the injection solution from the tank through a manifold system that was designed to deliver the emulsified oil/buffer solution to up to 7 wells at a time. The injection system included a flow meter/totalizer upstream of the manifold, and individual flow meters and pressure gauges at each of the well heads where injections were being performed. Flow was initiated to each injection well and monitored continuously for flow rate and pressure.

A total of 1380 gallons of the emulsified oil/buffer solution was injected. Each well received an average of 69 (\pm 25) gallons of the injection solution, with the total volume varying from 14 gallons in IW-18 where the well seal failed, to 120 gallons in IW-8 (**Table 5.9**). Once injections were complete at each well, a small volume of unamended chase water (3 to 5 gallons of the same groundwater used in the injection solution) was added to the well to clear the injection solution from the well, and push the amendments further into the formation. The variation in injection volume per well reflected the flow rate and pressure observed at each well during the injection, which in turn, was consistent with the geologic heterogeneity of the site. In general, the emulsified oil solution was added to 5-7 wells at a time using the manifold system, and the injection was planned so that adjacent wells were not amended at the same time to minimize pressure in the local aquifer. Because of the geology of the test plot area, which included significant clay layers

between more permeable zones, the average flow rate to the wells was generally maintained between 0.1 and 0.5 GPM. The pressure at the well head of each IW was kept below 5 psi during the injection to avoid failure of the well seals and/or daylighting to the surface away from the well. The emulsified oil injection in all 20 IWs was completed over a period of 3.5 days, and provided no disruption to range activities, as the site was on standby for quarterly groundwater sampling. This time could easily be reduced at sites where the local aquifer is more conductive, and faster pumping rates could be achieved.

A second oil injection was performed after 20 months when there were indications that contaminant removal effectiveness was reduced downgradient of the biobarrier. Injection logs are shown in **Table 5.10**. For this injection, a solution containing 9.5% (v:v) EOS 550LS was mixed in site groundwater with 0.75% (v:v) EOS CoBupH. The injectate was introduced into a subset of the seven centermost barrier wells (IW-5 to IW-11) and IW-19, which was near the area of a planned push-pull test to be performed at the conclusion of the field demonstration. A total of 585 gallons of the emulsified oil/buffer solution was injected. The total volume injected into each of the wells varied from 15 gallons in IW-9 and IW-11 to 130 gallons in IW-13. A small volume (2.5 to 17 gallons) of clean chase water was injected into each well after the emulsified oil/buffer solution to move the solution further into the formation.

Figure 5.30. Summary of emulsified oil biobarrier design parameters.

Single Permeable Reactive Barrier - Selected Design			
This sheet shows a summary of the selected design that can be saved or printed before looking at alternative designs.			
1 Site Information			
a	Name	NSWC Dahlgren	
b	Description (e.g., project number)	139467	
c	Location	Dahlgren, VA	
d	Maximum Oil Retention	0.002	lbs oil/lbs soil
2 Design Information			
a	Reinjection Interval	5	years
b	Total Project Life	5	years
c	Minimum Allowable Contact time	7	days
3 Well Layout			
a	Well Spacing	5	ft
b	Number of Rows	1	rows
c	Total Number of Wells	20	wells
4 Logistics for Each Injection Event			
a	Total Mass of Oil Injected	124	lbs
b	Total Injection Volume	771	gallons
c	Total Injection Volume per well	39	gal/well
d	Estimated Injection Rate	0.3	gpm/well
e	Number of wells injected simultaneously	10	wells
5 Costs for Initial Installation and Injection			
a	Fixed Costs (engineering and installation)	\$4,350	
b	Well Installation Costs	\$6,850	
c	Labor Cost for Injection	\$8,050	
d	Substrate Costs	\$362	
e	Total Installation and Injection Costs	\$19,612	
6 Costs for Future Injection Events			
a	Fixed Costs (engineering and installation)	\$3,850	
b	Well Rehabilitation and/or Installation Costs	\$1,713	
c	Labor Cost for Injection	\$8,050	
d	Substrate Costs	\$362	
e	Total Installation and Injection Costs	\$13,975	
7 Total Life Cycle Costs			
a	Annual Interest Rate	2%	
b	Monitoring and Reporting	\$23,567	
c	Total Injection Costs (fixed, well installation, labor for injection, and substrate)	\$32,269	
d	Project Life NPV	\$55,837	
8 Design Parameters			
a	Substrate Scaling Factor	0.5	
b	Volume Scaling Factor	1.0	
c	Mass Scaling Factor	1.0	
d	Estimated Contact Efficiency for Injection	85%	to 94%

Table 5.9. Initial emulsified oil injection logs (February 2013).

Injection Well	2/5/2013			2/6/2013			2/7/2013			Injection Total (gallons)	Comments
	Average Flow Rate (gpm)	Average Injection Pressure (psi)	Daily Injection Total (gallons)	Average Flow Rate (gpm)	Average Injection Pressure (psi)	Daily Injection Total (gallons)	Average Flow Rate (gpm)	Average Injection Pressure (psi)	Daily Injection Total (gallons)		
IW-1				0.3	2.1	90.0	0.27	4.0	53.2	90.0	
IW-2				0.3	2.2	30.0				83.2	
IW-3	0.24	3.5	79.0							79.0	
IW-4				0.3	2.4	65.0	0.3	3.5	18.7	83.7	
IW-5				0.3	2.6	55.0	0.3	3.0	22.2	77.2	
IW-6	NM	NM	25.0	0.32	0.5	64.0				89.0	25 gal injection estimated for 2/5/13 - flow meter issues.
IW-7				0.3	3.0	90.0				90.0	
IW-8	0.25	1.3	75.0	0.3	2.5	45.0				120.0	
IW-9				0.12	5.0	57.0				63.0	
IW-10							0.13	6.5	6.0	73.5	
IW-11				0.14	5.0	65.0	0.24	5.2	73.5	73.5	
IW-12				0.25	1.1	25.0	0.15	6.4	11.0	76.0	
IW-13				0.14	4.8	39.0	0.22	2.8	32.0	25.0	Seal blown. Could not inject any more material.
IW-14							0.1	7.0	22.6	71.0	
IW-15	0.21	3.5	63.0							63.0	
IW-16							0.3	0.5	69.8	69.8	
IW-17	0.25	2.0	62.0							62.0	
IW-18	0.25	4.0	14.0							14.0	Seal blown. Could not inject any more material.
IW-19							0.35	0.5	71.0	71.0	
IW-20	0.2	3.5	57.0							57.0	
Totals			375.0			625.0			380.0	1380.0	

Table 5.10. Second emulsified oil injection logs (October 2014).

10/07/14 - 10/08/14							
Injection Well	Average Flow Rate (gpm)	Average Injection Pressure (psi)	EOS LS/ Water Mix Injection Volume (gal.)	Chase Water Injection Volume (gal.)	Total Injection Volume (gal)	Volume of EOS LS Injected (gal.)	Volume of CoBupH Injected (gal.)
IW-5	0.2	2.5	80	5	85	7.52	0.68
IW-6	0.2	0.4	65	10	75	6.11	0.56
IW-7	0.2	2.5	130	10	140	12.22	1.11
IW-8	0.25	4.0	110	17	127	10.34	0.94
IW-9	0.015	5.0	15	2.5	17.5	1.41	0.13
IW-10	0.20	3.0	95	10	105	8.93	0.81
IW-11	0.015	5.0	15	2.5	17.5	1.41	0.13
IW-19	0.3	0.0	75	8	83	7.05	0.64
Totals			585.0	65.0	650.0	55.0	5.0

Figure 5.31. Schematic of demonstration plot layout.

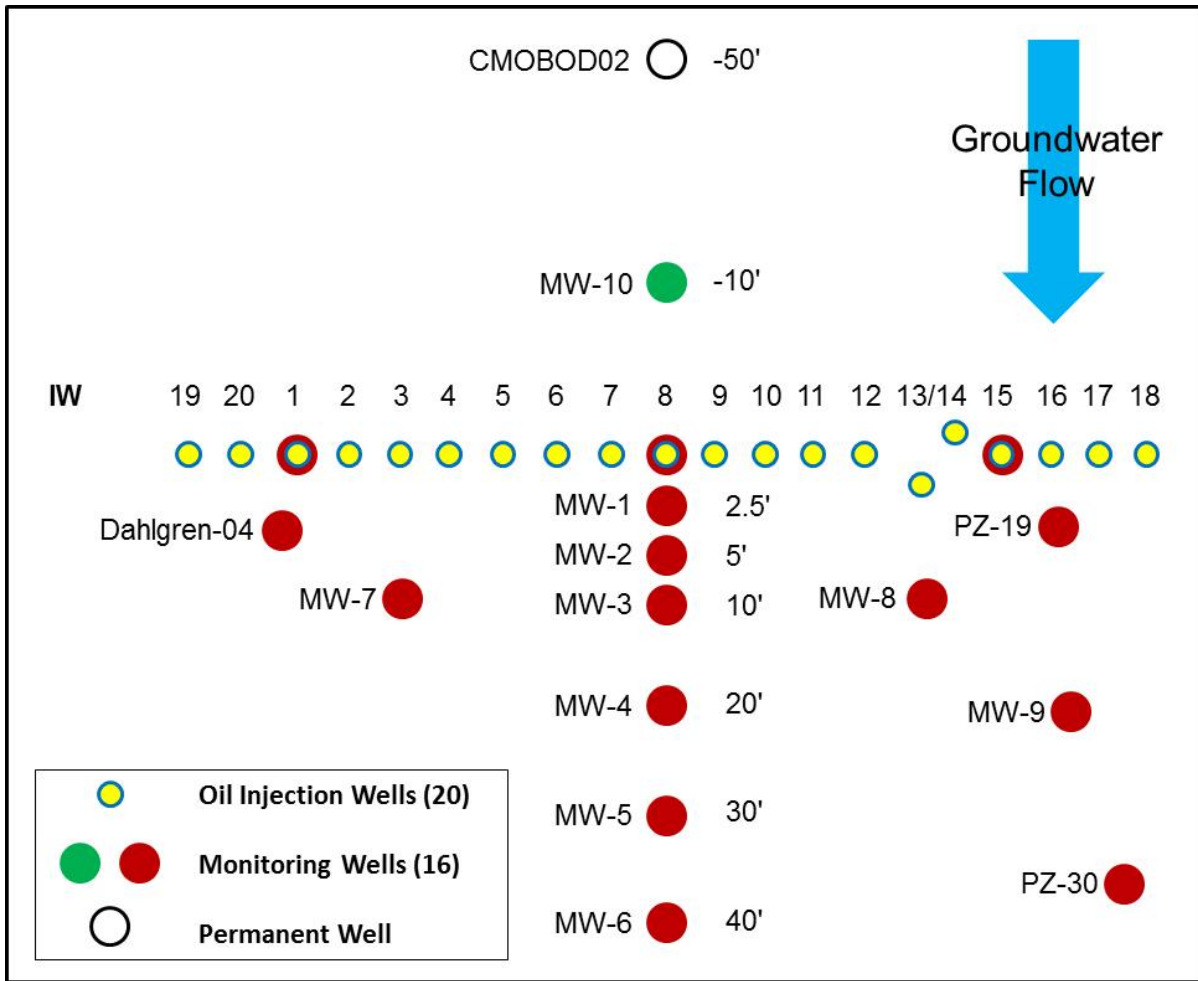

5.4 FIELD TESTING

The contaminant concentrations in the demonstration plot was monitored for period of 30 months, with two rounds of baseline sampling in the four months prior to oil injection, and 10 round of sampling after oil injection. Sampling details are provided below.

5.4.1 Biobarrier Monitoring

Two initial rounds of baseline sampling were conducted prior to barrier installation. Once biobarrier installation was complete, ten (10) groundwater sampling events were conducted that include all wells shown in **Figure 5.31**. The final sampling schedule is shown below in **Table 5.10**.

5.4.2 Analysis of RDX Degrading Bacteria

Stable isotope probing (SIP) was used to distinguish key degradative microorganisms under natural conditions based upon their incorporation of stable isotope-labeled carbon (^{13}C -RDX) and/or nitrogen (^{15}N -RDX) from the contaminants into their nucleic acids (e.g., DNA). Application of this technique was initially developed during SERDP Projects ER-1378 and ER-1607.

An initial set of SIP experiments were performed using site aquifer sediments and groundwater to assess microbial communities degrading RDX under various electron acceptor conditions. Groundwater and sediment were combined in 8-L steel kegs, and amended with succinate as an electron donor and one of the following as a dominant electron acceptor: nitrate, Fe^{3+} , Mn^{4+} , SO_4^- , nothing (methanogenic). The kegs were incubated at 15°C and were repeatedly amended with succinate, unlabeled RDX, and the electron acceptor until good activity was established. The contents of each keg was then divided among four bottles, that received either unlabeled RDX, $^{13}\text{C}_3$ -RDX, ring- $^{15}\text{N}_3$ -RDX or nitro- $^{15}\text{N}_3$ -RDX. Additional succinate and respective electron donor was added. After the RDX was degraded, the DNA in the samples was isolated and subjected to density gradient centrifugation. The resulting isotopically-enriched nucleic acids were analyzed using multiple molecular techniques. Terminal restriction fragment length polymorphism (t-RFLP) analysis was used to visualize the overall microbial community profile. Cloned 16S sequences from the unlabeled and labeled DNA fractions were compared to the currently known RDX-degrading bacteria (i.e., aerobic *Gordonia*, *Rhodococcus*, and *Williamsia* sp.; facultative anaerobic *Pseudomonas* and *Klebsiella* spp.; and anaerobic *Desulfovibrio* and *Clostridia* spp.), thus allowing an assessment of the overall importance of these known RDX-degrading bacterial genera during in situ RDX degradation.

5.4.3 System Shutdown and Demobilization

At the conclusion of the demonstration, the status of all piezometers was discussed with NSW, Dahlgren environmental personnel. The flush-mounted piezometers used as injection and monitoring wells for the biobarrier were left in place after the demonstration with concurrence from NSW personnel. All other piezometers were removed or cut below ground level and the holes filed with bentonite. No other demobilization activities were required.

Table 5.11. Sampling and field events schedule.

YEAR	MONTH	NOTES
2012	OCT	Baseline Sampling
2013	JAN	Baseline Sampling
	FEB	Oil Injection
	MAR	Sampling
	MAY	Sampling
	JUNE	Sampling
	AUG	Sampling
	OCT	Sampling
2014	FEB	Sampling
	JUNE	Sampling
	OCT	Sampling / Oil Injection
2015	MAR	Sampling
	AUG	Sampling

5.5 SAMPLING PLAN

5.5.1 Groundwater Sampling

Groundwater samples were collected by CB&I personnel utilizing low-flow purging in general accordance with EPA Low-Flow Ground-Water Sampling Procedures (Puls and Barcelona, 1995) (**Appendix E**). Prior to each sampling event, the well ID was checked and recorded on a field sheet, then groundwater elevation measurements was collected using an electronic water level probe (ORS Model #1068013 or equivalent) prior to collecting groundwater samples. Measurements were obtained from the top-of-casing and recorded to the nearest 0.01-ft, and were recorded in the field logbook. The tubing used to sample the wells was dedicated and therefore did not require decontamination.

A peristaltic pump was used to withdraw water from the wells at a flow rate of 0.1 to 0.5 L/min, and the water level in the well was monitored. It was desirable, although not always achievable, that the groundwater pumping leads to <0.3 meters of drawdown in the well, so the pumping rate was adjusted accordingly (i.e., if drawdown is too great, the pumping rate will be reduced). For some of the Dahlgren wells, drawdown was greater than 0.3 meters even at 0.1 L/min due to low groundwater yield. The extent of drawdown in each well was recorded during stabilization.

The well was pumped through a flow cell connected to an in-line multi-parameter groundwater meter (e.g., Horiba Model U-22 or equivalent). Parameters, including temperature, conductivity, dissolved oxygen, oxidation-reduction potential (ORP), turbidity, and pH were measured as a function of pumping time, and the values recorded on a field sheet every 5 to 10 minutes. An example field sheet is provided in **Figure 5.32**. Water was purged from the well until all parameters were stable for three consecutive readings. Stability was defined as variation of <1% for pH, <3% for temperature and specific conductivity, and <10% for dissolved oxygen, ORP, and turbidity. When parameters were stable according to the above guidelines, sampling time was recorded and all samples were collected (See Section 5.5.2). Some wells produced groundwater

so slowly that collection of samples occurred after the well was pumped “dry” and then allowed to fill back up several times. These wells also resulted in only partial collection of field parameters, as the flow cell could not effectively be filled and flushed. The final data collected on each field sheet was recorded in the project database as the measured readings in each well. All field meters were calibrated each day of sampling, and recalibrated as needed.

5.5.2 Analytical

Groundwater samples were collected and analyzed for basic field parameters, as described in Section 5.5.1, as well as the analytes listed in **Table 5.12**. The analytes, methods, sample bottles and preservatives are also provided in **Table 5.12**. Samples were collected for all analytes from all wells for all sampling events, resulting in 204 datapoints per analyte, excluding missing samples due to dry wells. CB&I’s Analytical and Testing Laboratory in Lawrenceville, New Jersey performed analysis for explosives (EPA 8330), perchlorate (EPA 314.0), anions (EPA 300), VFA (EPA300m), TOC (SM5310B,C,D), and dissolved gases (EPA 3810m). An outside laboratory approved by CB&I performed analysis for TAL metals (EPA 200.7).

5.5.3 Quality Assurance for Groundwater Sampling and Analysis

5.5.3.1 Calibration Procedures and Frequency.

Calibration refers to the checking of physical measurements of both field and laboratory instruments against accepted standards. It also refers to determining the response function for an analytical instrument, which is the measured net signal as a function of the given analyte concentration. These determinations have a significant impact on data quality and will be performed regularly. In addition, preventative maintenance is important to the efficient collection of data. The calibration policies and procedures set forth applied to all test and measuring equipment. For preventative maintenance purposes, critical spare parts were obtained from the instrument manufacturer.

All field and laboratory instruments were calibrated according to manufacturers’ specifications. All CB&I laboratory instruments were calibrated in accordance with established Standard Operating Procedures (SOPs). Calibration were performed prior to initial use and after periods of non-use. A record of calibration was made in the field logbook each time a field instrument is calibrated. A separate logbook was maintained by CB&I laboratory QA personnel similarly for laboratory instrumentation.

5.5.3.2 Field Measurements: Groundwater.

Groundwater was analyzed for dissolved oxygen, pH, temperature, ORP, and specific conductivity with a field meter. Depth to groundwater measurements were taken using a water interface probe. The field meter was calibrated at the beginning of each day and as necessary thereafter if anomalous readings are observed for any parameter.

5.5.3.3 Laboratory Measurements.

The calibration procedures for all off-site analyses followed the established SW-846 and U.S. EPA guidelines for the specific method (see **Appendix F** for method SOPs on non-standard methods). Certified standards were used for all calibrations and calibration check measurements.

5.5.3.4 Quality Control Samples

Internal QC data provides information for identifying and defining qualitative and quantitative limitations associated with measurement data. Analysis of the following types of QC samples provided the primary basis for quantitative evaluation of field data quality:

Field QC Samples:

- Trip blanks are often used to evaluate the presence of contamination from handling errors or cross-contamination during transport, particularly for VOCs. Trip blanks are often not necessary when the contaminants of concern are non-volatile (e.g., RDX, HMX, and perchlorate);
- field duplicates to assess the homogeneity of samples received by the laboratory as well as the homogeneity of contaminants in the matrix.

Trip Blanks. Because all target contaminants are non-volatile, trip blanks are deemed unnecessary for this project and none will be included in the sampling regime.

Field Duplicate Samples. Field duplicate samples were collected and analyzed for target contaminants and other analytes to evaluate the accuracy of the analytical process. Duplicate samples were analyzed as described below. A field duplicate was collected from a random well with each set of field samples collected during each round of field sampling. A comparison of the detected concentrations in the duplicate samples was performed to evaluate precision. The evaluation was conducted using a Relative Percent Difference (RPD) calculation as shown below

$$RPD = (C_1 - C_2) * 100 / ((C_1 + C_2) / 2) \quad (2)$$

Where: RPD = relative percent difference
C₁ = the larger of the two observed values
C₂ = the smaller of the two observed values

Figure 5.32. Example groundwater parameter stabilization form for low flow sampling.

ESTCP BIOBARRIER									
ESTCP Project ER-201028									
CB&I PROJECT NO. 139467									
Dahlgren NSWC									
MONITORING WELL ID:					Sampling Date:				
Well Depth [ft-btoc]:					Sampler(s):				
Depth to Water Prior to Purging [ft-btoc]:					Sampling Device: peristaltic				
					Probe S/N:				
Well Casing Diameter [in]:					Weather Conditions:				
Start Time (purging):									
FIELD PARAMETERS									
Time [hh:mm]	pH [std]	Temperature [°C]	Dissolved Oxygen [mg/l]	Redox Potential [mV]	Specific Conductance [µS/cm]	Turbidity [ntu]	Depth To Water [ft-btoc]	Volume Purged [liters]	Approximate Purge Rate [ml/min]
Stabilization Criteria	+/- 1%	+/-3%	+/-10%	+/-10mV	+/-3%	+/-10%	not to exceed 0.3 feet drawdown	/	100 to 500 mL/min
Sample Time: _____									
SPE Sampling		Y / N	Volume		# Columns				
STERIVEX sampling		Y / N	Volume		# Filters				
Comments:									

Table 5.12. Analytical methods and total samples collected during the field demonstration.

	Analyte	Method/ Laboratory	Preservative	Bottle
Process Parameters	ORP Dissolved Oxygen pH Conductivity Temperature	Field Meter	--	--
	Anions	EPA 300.0 CB&I	4°C	100 mL polyethylene screw- cap (x1)
	Total Organic Carbon (TOC)	SM5310B,C ,DCB&I	4°C with H ₃ PO ₄	100 mL polyethylene screw- cap (x1)
	Volatile Fatty Acids	EPA 300m CB&I	4°C	40 mL VOA vial (x2) No headspace
Target Analytes	Explosives (RDX, HMX, nitroso intermediates)	EPA 8330 CB&I (modified)	4°C Some with HCl added after arrival at laboratory	950 mL amber glass screw-cap (x2)
	Perchlorate	EPA 314.0 CB&I	Cellulose acetate syringe filter (0.2 µm) and 4°C	50 mL sterile polyethylene screw- cap tube (x2)
Groundwater Quality Analytes	TAL Metals (Fe, Mn, As)	EPA 200.7 External	Capsule filter, 4°C with HNO ₃	100 mL polyethylene screw- cap (x1)
	Dissolved Gases (methane)	EPA 3810, RSK175 CB&I	4°C with HCl	40 mL VOA vial (x2) No headspace

5.5.3.5 Sample Documentation

The on-site Field Engineer coordinated with the off-site laboratories for shipment and receipt of sample bottle, coolers, ice packs, and chain-of-custody (COC) forms. Upon completion of sampling, the COC was filled out and returned with the samples to the laboratory. The COC provided evidence of collection, shipment, laboratory receipt, and laboratory custody until disposal of each sample, as well as providing a record of the names of the individuals responsible for sample collection, transport, and receipt. A sample is considered in custody if it is:

- in a person's actual possession;
- in view after being in physical possession;
- sealed so that no one can tamper with it after having been in physical custody; or
- in a secured area, restricted to authorized personnel.

A sample COC used by CB&I's laboratory is shown in **Figure 5.33**. Sample custody was initiated by field personnel upon collection of samples. Samples were packaged appropriately to prevent breakage or leakage during transport, and were shipped or transported and delivered by hand to the CB&I Lawrenceville analytical laboratory. Samples for TAL metals were repackaged and shipped to the outside laboratory via commercial carrier.

5.5.3.6 Sample Identification

A discrete sample identification or well number was assigned to each sample. This discrete identifier was placed on each bottle and also on the COC, along with the sampling date. Field duplicate samples will be further identified as "Dup".

5.5.3.7 Laboratory Sample Receipt

Following sample receipt, the Laboratory Manager:

- Examined all samples and determine if proper temperature has been maintained during transport. If samples were damaged during transport, the remaining samples were carefully examined to determine whether they were affected. Any samples affected were considered damaged. It was noted on the COC record that specific samples were damaged and that the samples were removed from the sampling program.
- Compared samples received against those listed on the COC record.
- Verified that sample holding times were not exceeded.
- Signed and dated the COC record, attaching the waybill if samples were shipped for off-site analysis.
- Denoted the samples in the laboratory sample log-in book which contained, at a minimum, the following information:
 - ❖ Project identification number
 - ❖ Sample numbers
 - ❖ Type of samples
 - ❖ Date and time received.

The completed COC Record was placed in the project file upon receipt of the results.

5.5.3.8 Other Documentation

Following sample receipt at the laboratory, the Laboratory Manager or sample custodian established the processing steps that applied to the sample. The analytical data from laboratory QC samples were identified with each batch of related samples. The laboratory log book included the time, date, and name of the person who logged each sample into the laboratory system. This documentation was thorough enough to allow tracking of the sample analytical history without aid from the analyst. At a minimum, laboratory documentation procedures:

- Were written in a clear, comprehensive manner using indelible ink;
- Had any needed corrections to data and logbooks made by drawing a single line through the error and initialing and dating the correction;
- Demonstrated consistency before release of analytical results by assembling and cross-checking the information on the sample tags, custody records, bench sheets, personal and instrument logs, and other relevant data to verify that data pertaining to each sample were consistent throughout the record;
- Contained appropriate observations and results identified with the project number, date, and analyst and reviewer signatures on each line, page, or book;
- Recorded data in bound books or sheaf of numbered pages, instrument tracings or hard copy, or computer hard copy; and,
- Allowed data tracking through document consolidation and project inventory of accountable documents: sample logbook, analysis data book, daily journal, instrument logbook, narrative and numerical final reports, etc.

Figure 5.33. Chain of Custody (COC) form used by CB&I's analytical laboratory.



CB&I - Federal Services, LLC
17 Princess Rd
Lawrenceville, NJ 08648
609-895-5370/ 609-895-1858

CHAIN OF CUSTODY

Ref. Document # _____
 Page _____ of _____

Lab ID # <i>labuse</i>	<input checked="checked" type="checkbox"/> R&D	Project Number/Cost code: _____ Project Name / Location: _____ Purchase Order #: _____	<table border="1" style="width: 100%; border-collapse: collapse;"> <thead> <tr> <th colspan="2">Analyses Requested</th> </tr> <tr> <th style="writing-mode: vertical-rl; transform: rotate(180deg);">Any Additional Information</th> <th style="writing-mode: vertical-rl; transform: rotate(180deg);">Turn Around Time Requested</th> </tr> </thead> <tbody> <tr><td> </td><td> </td></tr> <tr><td> </td><td> </td></tr> <tr><td> </td><td> </td></tr> <tr><td> </td><td> </td></tr> <tr><td> </td><td> </td></tr> <tr><td> </td><td> </td></tr> <tr><td> </td><td> </td></tr> <tr><td> </td><td> </td></tr> <tr><td> </td><td> </td></tr> </tbody> </table>	Analyses Requested		Any Additional Information	Turn Around Time Requested																		
Analyses Requested																									
Any Additional Information	Turn Around Time Requested																								
Project Contact: <i>Chuck Condee</i> <small>(Name & phone #)</small>		Shipment Date: _____ Waybill/Airbill Number: _____ Lab Destination: _____ Lab Contact Name / ph. #: _____																							
Send Report To: _____ Phone/Fax Number: _____ Address: _____ City/State: _____																									

Sampler's Name(s): _____			Collection Information			Preservative							
			Date	Time	G/C	HCL	NaOH	HNO ₃	H ₂ SO ₄	Ice			
Lab No.	Sample ID Number	Sample Description	Date	Time	G/C	Matrix	# of containers	Container size	HCL	NaOH	HNO ₃	H ₂ SO ₄	Ice

Special Instructions:	Known Waste Stream Circle: PCBRA: <input type="checkbox"/> PCB/dioxin <input type="checkbox"/> PAH/oil <input type="checkbox"/> RAD Corrosive <input type="checkbox"/> Flammable <input type="checkbox"/> Reactive	G/C Codes C = Composite G = Grab
	QC/Data Package Level Required: <input type="checkbox"/> I <input type="checkbox"/> II <input type="checkbox"/> III <input type="checkbox"/> IV <input type="checkbox"/> NJ EDD <input type="checkbox"/> GIS EDD <input type="checkbox"/> Preliminary data	QC Package Codes Level I = data summary Level II = data summary + basic QC Level III = New Jersey QC reduced deliverable Level IV = Full deliverable CLP package
Relinquished By: _____	Received By: _____	Date: _____
		Time: _____
Relinquished By: _____	Received By: _____	Date: _____
		Time: _____
Relinquished By: _____	Received By: _____	Date: _____
		Time: _____
Cooler temperature upon arrival at Lab:		

Instructions: Do not Fill Shaded Areas; Check R&D Box if R&D samples Only

5.6 DATA ANALYSES

The primary focus of the data analyses during the demonstration was to observe both temporal and spatial trends in perchlorate and RDX concentrations (as well as other explosives or breakdown products that may be present). Treatment effectiveness was measured by comparing RDX and perchlorate concentrations: (1) in each of the emulsified oil impacted downgradient monitoring wells before and after barrier installation, and (2) in the upgradient monitoring well with those in the downgradient treatment zone during each respective sampling event.

Preliminary quantification of temporal and spatial (along the groundwater flow path, thereby providing an assessment of residence time on perchlorate and RDX concentrations) biodegradation rates were determined via regression analysis using a pseudo zero or first order model. Decreases of each target contaminant in each well were assessed using appropriate statistical analyses (e.g., ANOVA.). Removal of RDX and perchlorate were compared to previous field demonstrations of other in situ remediation technologies in terms of degradation rates, half-lives, and overall percent reductions, as appropriate.

The demonstration objective was considered to be met if there were reductions in RDX and perchlorate in groundwater to $<1.08 \mu\text{g/L}$ and $<2 \mu\text{g/L}$, respectively, in one or more downgradient monitoring wells. These values correspond to the Virginia Groundwater Protection Standards for RDX (see **Table 1.1**) and the lowest state standard for perchlorate (Massachusetts MCL). The Virginia Groundwater Protection Standard for perchlorate is $70 \mu\text{g/L}$. Optimally, it was desired that all downgradient wells impacted by the biobarrier would reach these standards. A second standard-independent objective was an overall greater than 95% reduction in RDX and perchlorate concentrations in the downgradient monitoring wells between the pre-treatment to the post-treatment phases.

The mobilization of metals (Fe, Mn, As) and production of methane, and the downgradient dissipation of these compounds also was evaluated. Data for these compounds were analyzed by comparing their concentrations in each of the impacted downgradient monitoring wells before and after barrier installation, and relative to the upgradient monitoring well, both as a function of elapsed demonstration time and distance from the barrier.

6.0. DEMONSTRATION RESULTS

6.1 PROCESS PARAMETERS

The results related to the physical and chemical characteristics of the demonstration plot, and the effects of the biobarrier on groundwater geochemistry are presented below. Tabulated analytical results are provided in **Appendix G**.

Practical quantitation limits (PQL's) for laboratory based analyses are shown in **Table 6.1**. All analytes reported as below the detection limit were set equal to the PQL for purposes of calculating averages, standard deviations, etc., leading to a conservative interpretation of results and technology performance.

6.1.1 Precipitation, Depth to Water, and Groundwater Temperature

Precipitation at the site varied seasonally throughout the demonstration period, as shown in **Figure 6.1**. Several periods of both high and low precipitation were observed. The groundwater surface fluctuated seasonally as well, and in response to the changes in precipitation (**Figure 6.2**), leading to some difficulties in obtaining field parameters and samples for laboratory analysis from specific wells (e.g., MW-7 was particularly troublesome). As NSWC Dahlgren is located in the mid-latitudes of North America, and depth to groundwater was relatively shallow, the groundwater temperature also varied seasonally (**Figure 6.3**). The average groundwater temperature was 17 ± 5 °C (n=184) over the course of the demonstration. However, effects of temperature on other parameters or target compound degradation were not readily apparent. The data in **Figures 6.2 & 6.3** and many subsequent figures in this section represent the parameters measured along the centerline of the demonstration plot from upgradient well MW-10 to the farthest downgradient well MW-6, which is located ~ 40 ft from the barrier (See **Figure 5.31** for barrier illustration).

Table 6.1. Practical quantitation limits for laboratory analyses.

Analyte	PQL	Units	Analyte	PQL	Units
Cl	0.2	mg/L	Lactic	1	mg/L
NO2	0.2	mg/L	Acetic	1	mg/L
SO4	0.2	mg/L	Propionic	1	mg/L
Br	0.2	mg/L	Formic	1	mg/L
NO3	0.2	mg/L	Butyric	1	mg/L
Chlorate	0.2	mg/L	Pyruvic	1	mg/L
PO4	0.2	mg/L	Valeric	1	mg/L
TOC	2	mg/L			
			Al	12.5	µg/L
CLO4	0.5	µg/L	Sb	6.25	µg/L
Chlorate	0.2	mg/L	As	2.5	µg/L
			Ba	12.5	µg/L
MX	0.08	µg/L	Be	0.75	µg/L
DNX	0.08	µg/L	Cd	0.75	µg/L
TNX	0.08	µg/L	Ca	250	µg/L
HMX	0.03	µg/L	Cr	1.25	µg/L
RDX	0.03	µg/L	Co	3.75	µg/L
TNB	0.03	µg/L	Cu	2.5	µg/L
DNB	0.03	µg/L	Fe	12.5	µg/L
NB	0.03	µg/L	Pb	1.5	µg/L
TNT	0.03	µg/L	Mg	250	µg/L
2,4 DNT	0.03	µg/L	Mn	2.5	µg/L
Tetryl	0.03	µg/L	Ni	5	µg/L
4ADNT	0.03	µg/L	K	250	µg/L
2ADNT	0.03	µg/L	Se	5	µg/L
2,6 DNT	0.03	µg/L	Ag	1.25	µg/L
2-NT	0.03	µg/L	Na	250	µg/L
4-NT	0.03	µg/L	Tl	5	µg/L
			V	5	µg/L
Methane	2	µg/L	Zn	5	µg/L
Ethane	4	µg/L			
Ethene	5	µg/L			
Propane	6	µg/L			
Acetylene	7	µg/L			

Figure 6.1. Precipitation (in inches) received in the demonstration site area.

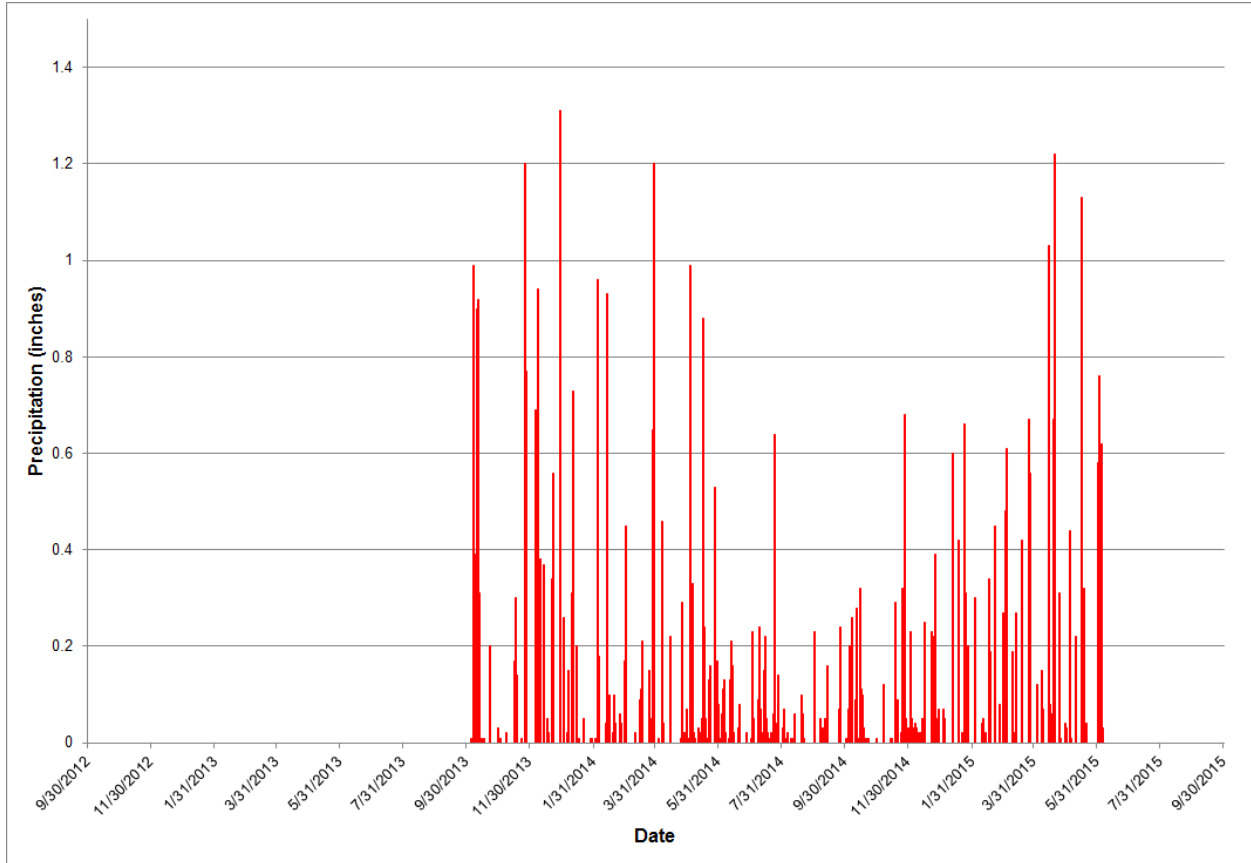

Biobarrier installation occurred in February 2013.

Re-injection of emulsified oil occurred in October 2014.

Figure 6.2. Depth to the water table (feet below the top of the well casing (TOC)) along the centerline of the demonstration plot.

A

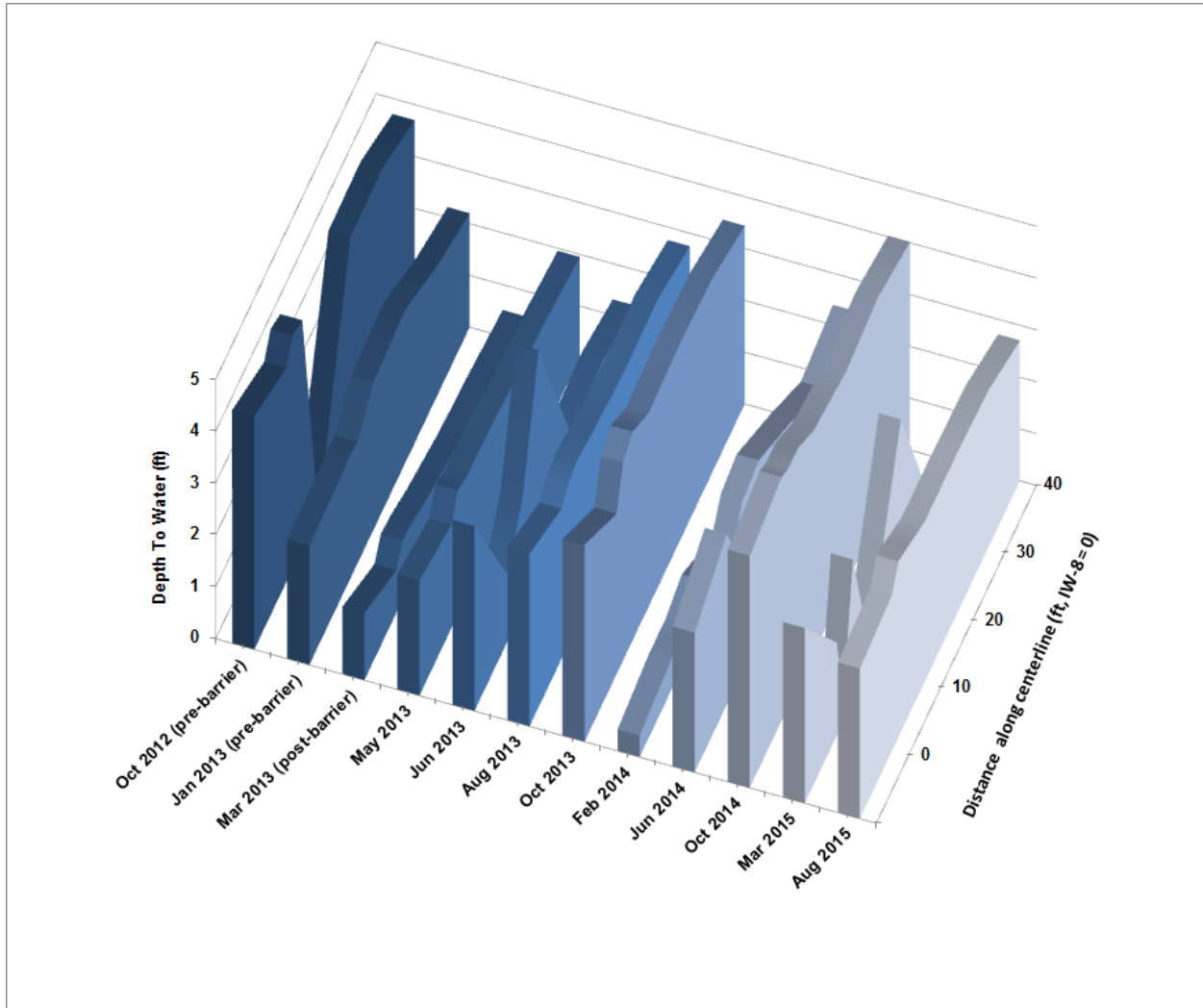

B

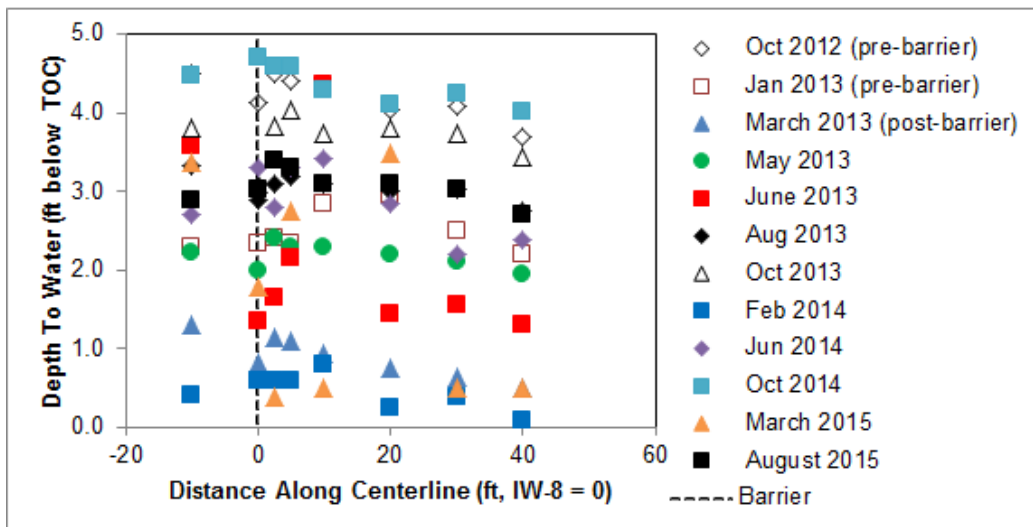
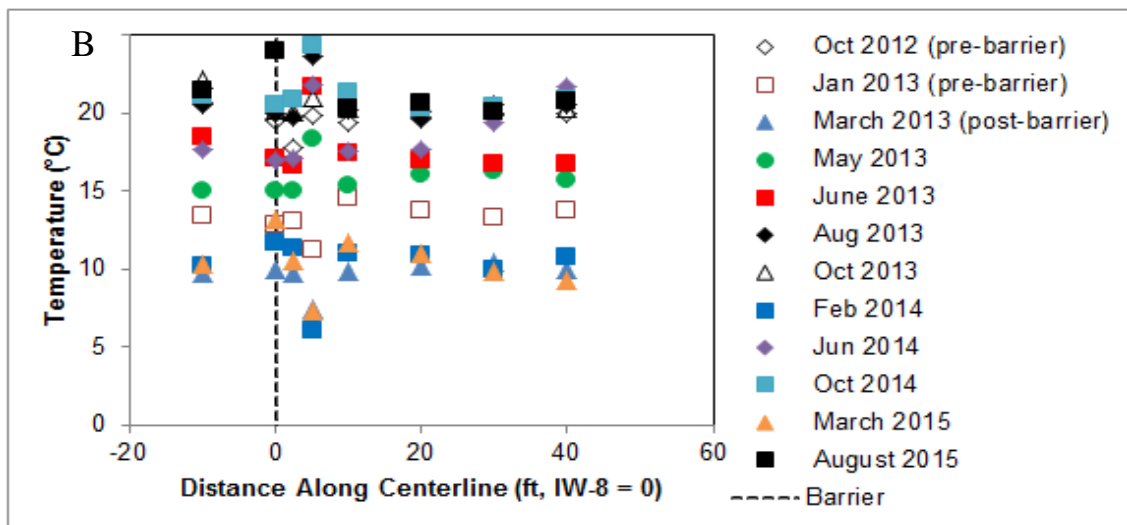
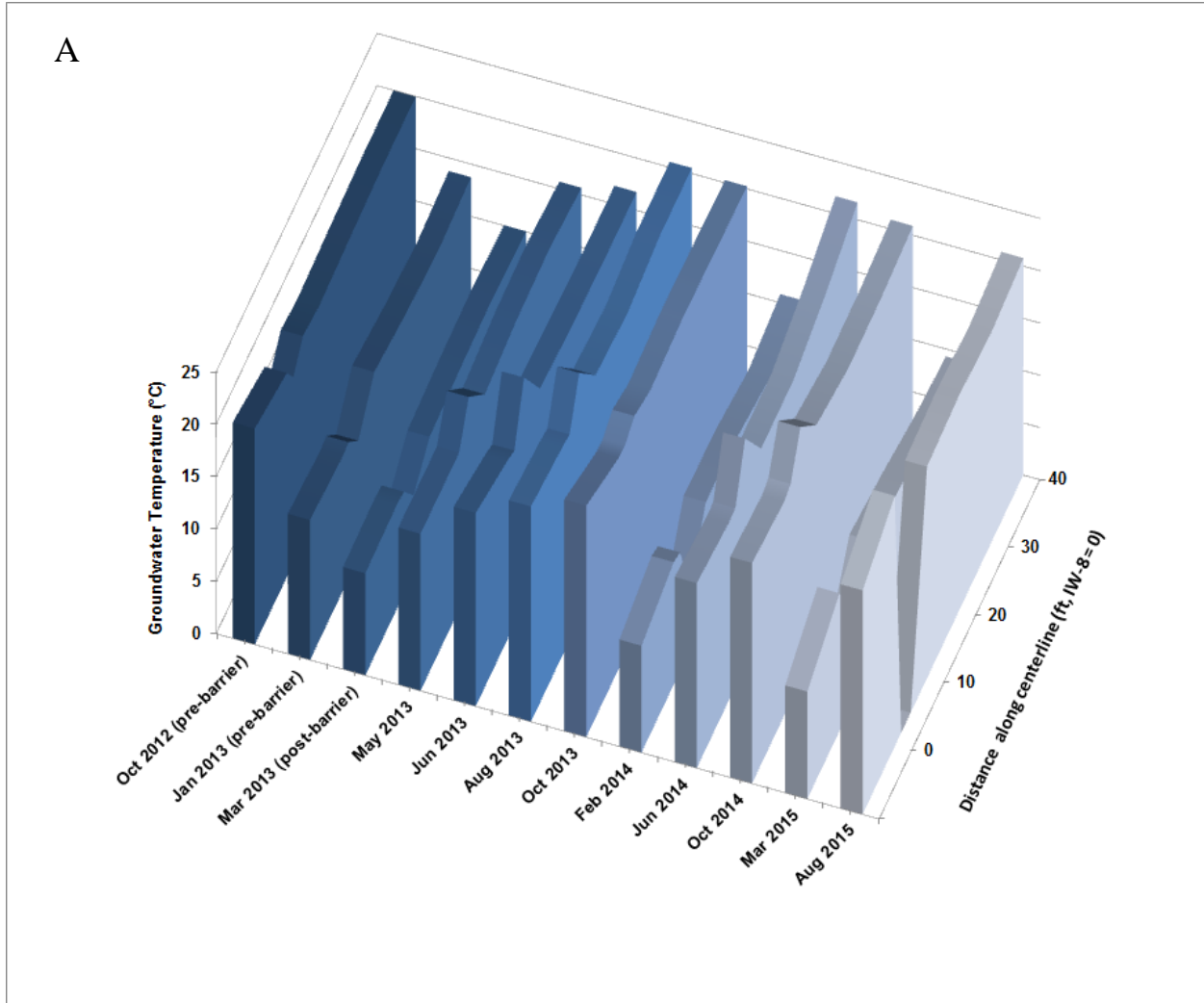

Figure 6.3. Groundwater temperatures during the demonstration period.



6.1.2 Dissolved Oxygen (DO) and Oxidation Reduction Potential (ORP)

The redox state of the demonstration plot was measured in the field via measurement of dissolved oxygen and oxidation-reduction potential. Background DO before the barrier installation averaged 3.0 ± 2.8 mg/L ($n = 27$) throughout the plot, with moderate variability from well to well. The upgradient monitoring well, MW-10, had average DO of 2.0 ± 0.9 mg/L ($n = 12$) over the duration of the demonstration. As expected, dissolved oxygen decreased in several downgradient wells upon emulsified oil injection (**Figure 6.4**). However, as seen in **Figure 6.5**, the DO at various places within the plot (upgradient, in-barrier, centerline, set distances from the barrier) was quite variable, likely reflecting the influence of groundwater depth and aerated precipitation recharge.

The ORP in the plot was somewhat less variable with respect to overall trends within the demonstration plot. Before the emulsified oil injection, the ORP averaged $+245 \pm 82$ mV ($n = 31$) across the plot. The ORP in MW-10, upgradient of the barrier, remained oxidizing at $+171 \pm 86$ ($n = 12$) during the demonstration. After barrier injection, ORP values along the downgradient centerline (0 to 40 ft downgradient) dropped quickly, then slowly increased over time (**Figure 6.6**). ORP did vary over time at various places within the test plot (**Figure 6.7**). Among the in-barrier wells, ORP remained negative throughout the demonstration (-72 ± 64 mV; $n = 30$) (**Figure 6.7B**). The average ORP along the centerline wells over the course of the entire demonstration was negative -9 ± 111 ($n = 58$), but with periods of positive ORP between initial injection and the second injection (**Figure 6.7B**).

These data support the use of emulsified oil injection to generate the reducing conditions required for both perchlorate and RDX biodegradation.

Figure 6.4. Dissolved oxygen concentrations along the demonstration plot centerline.
Emulsified oil was re-injected after the October 2015 sampling event.

A

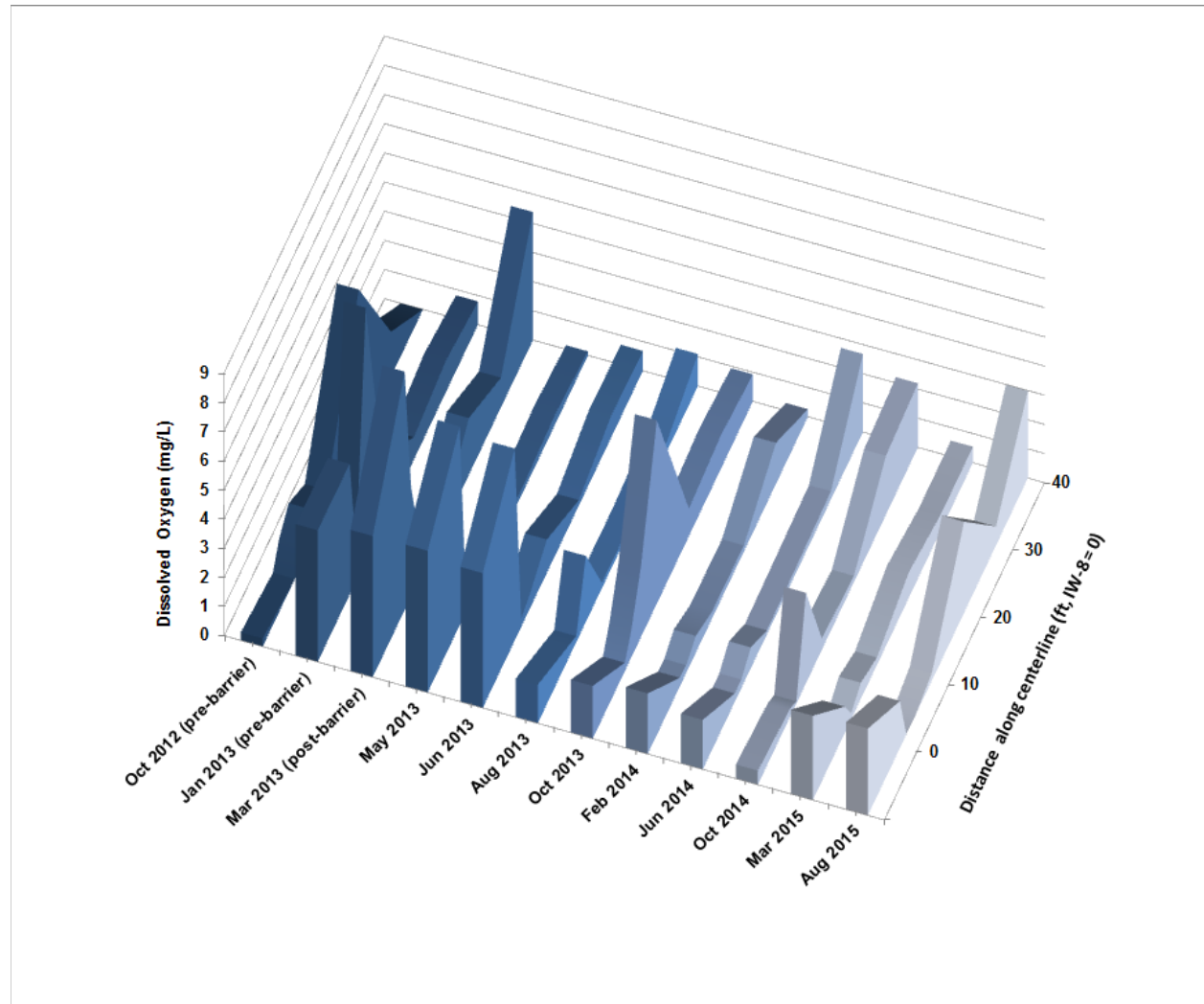

B

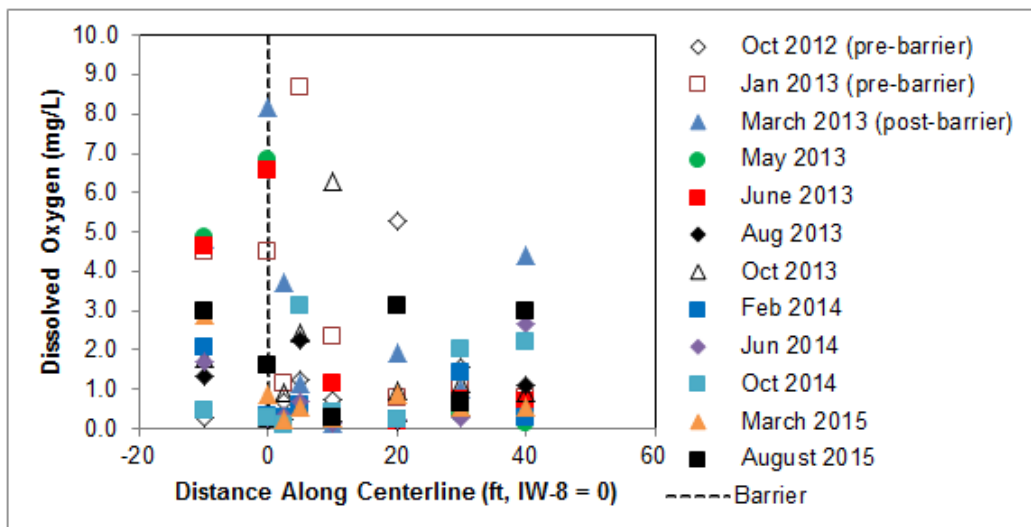

Figure 6.5. Dissolved oxygen concentrations over time in the demonstration plot. All wells are represented as a function of distance from the biobarrier in panel A and the upgradient, in-barrier, and centerline downgradient wells are represented in panel B.

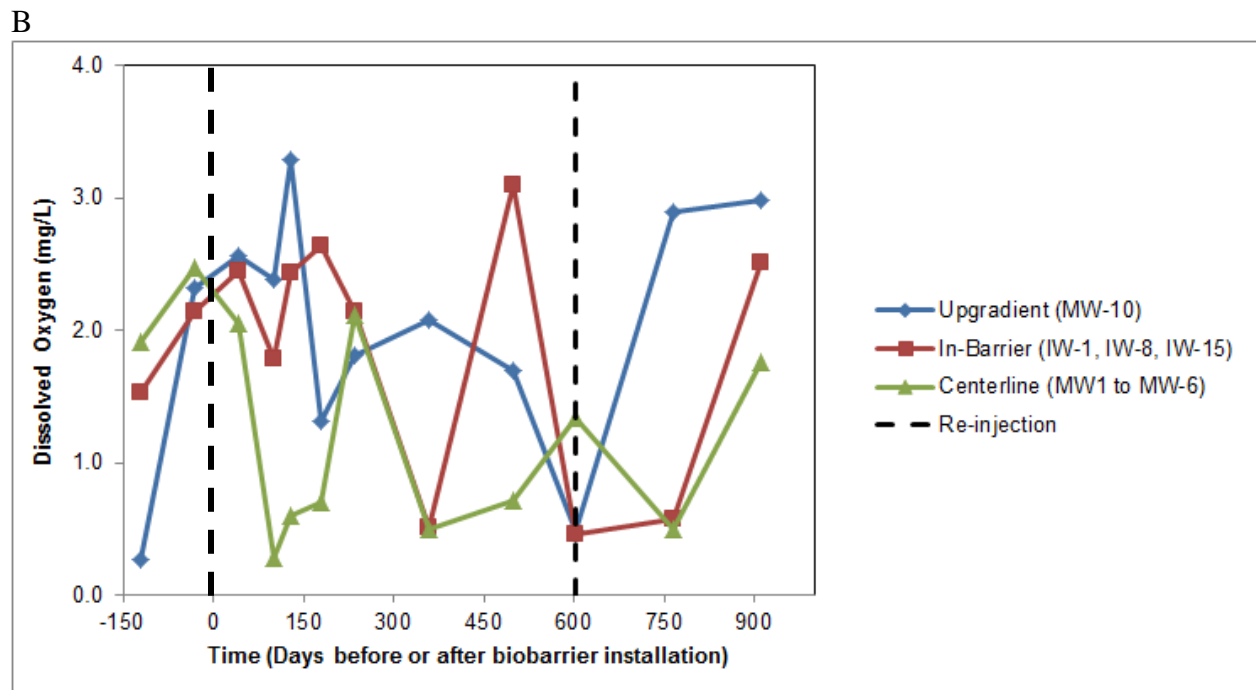
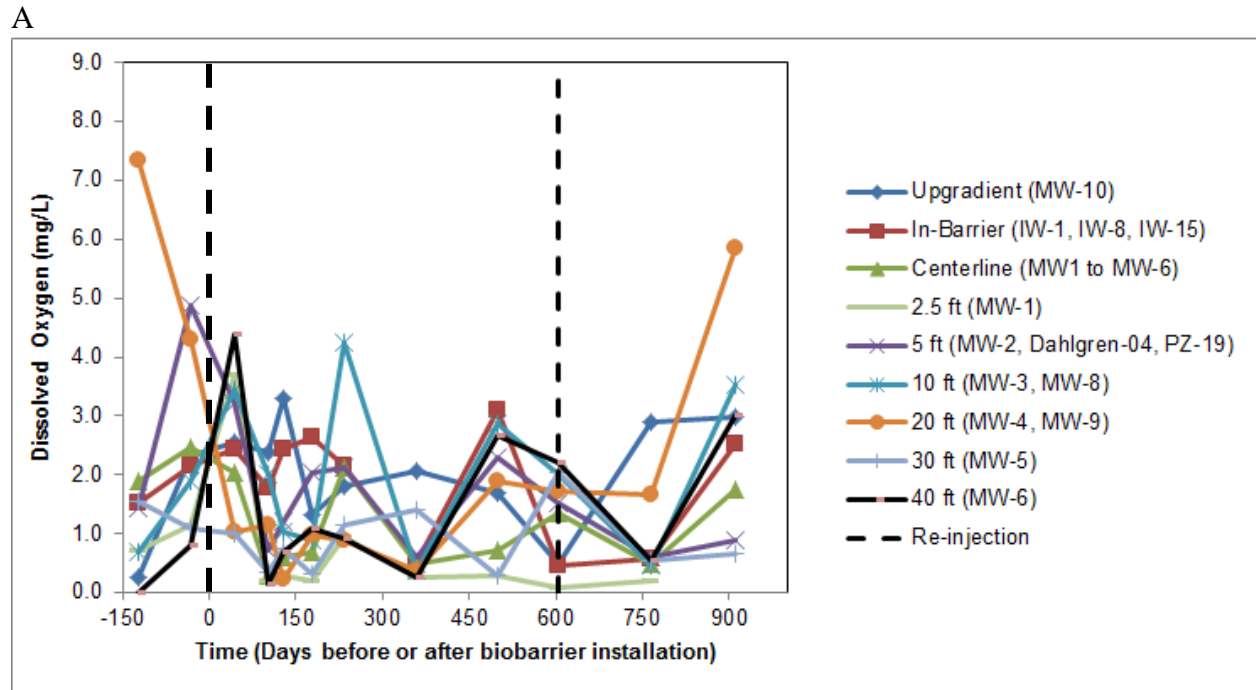
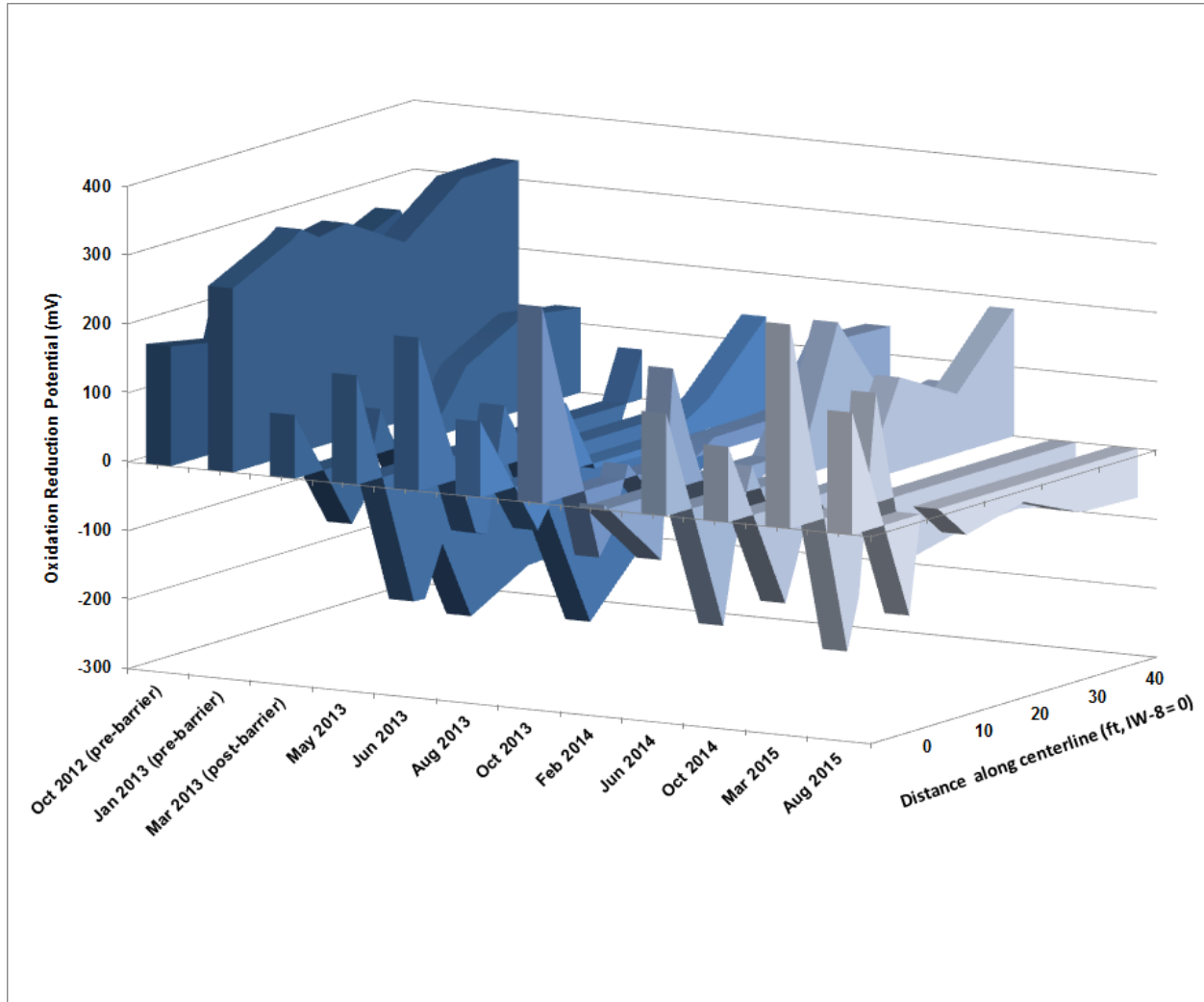

Figure 6.6. Oxidation-reduction potential along the demonstration plot centerline.
Emulsified oil was re-injected after the October 2015 sampling event.

A



B

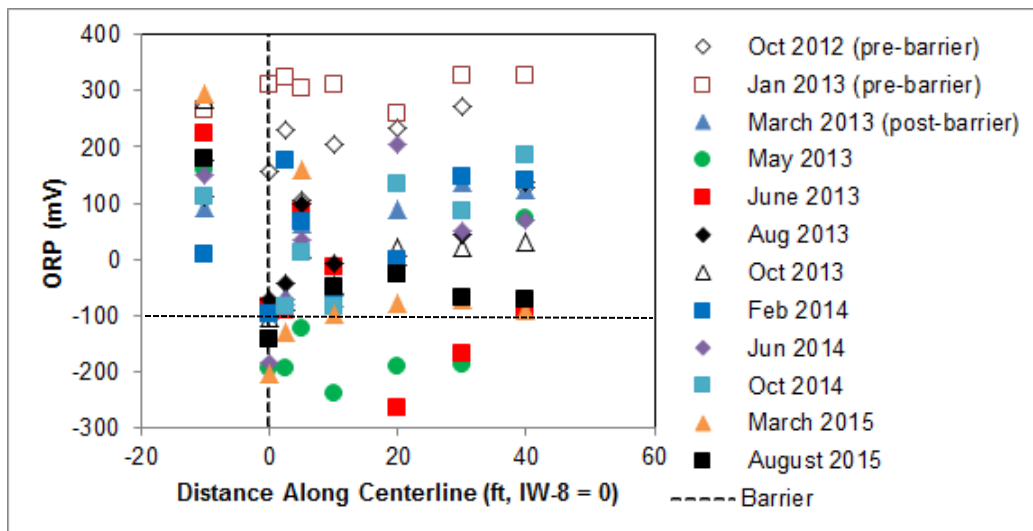
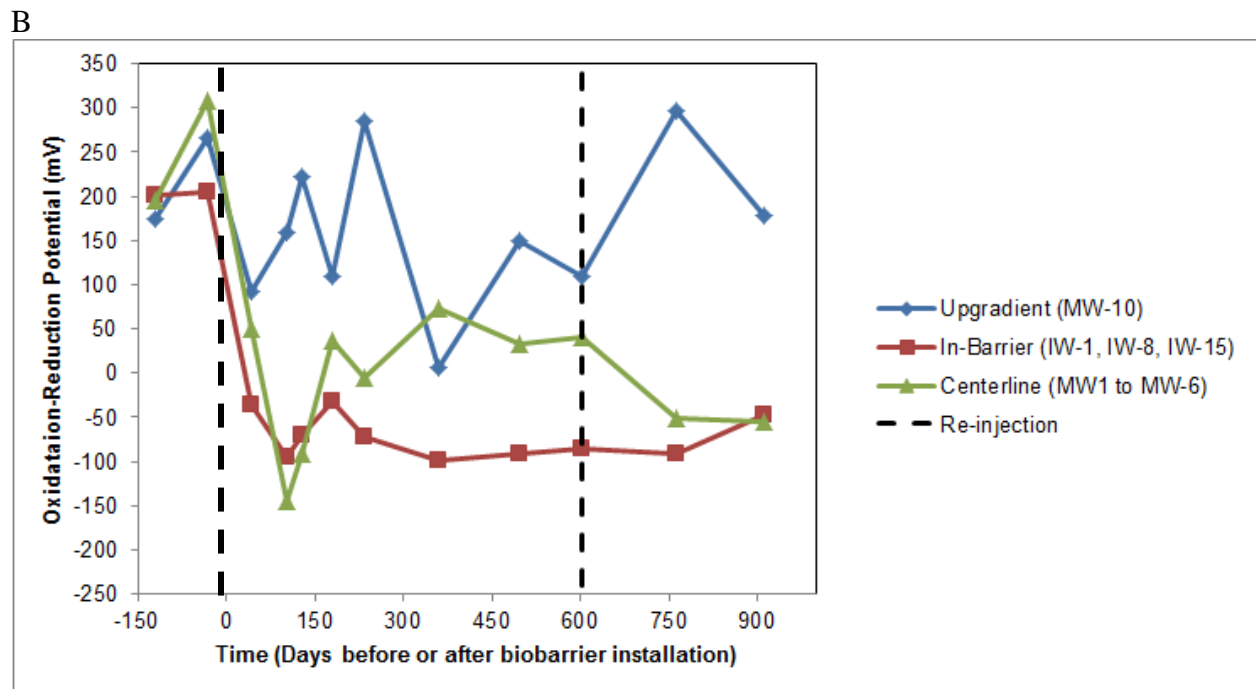
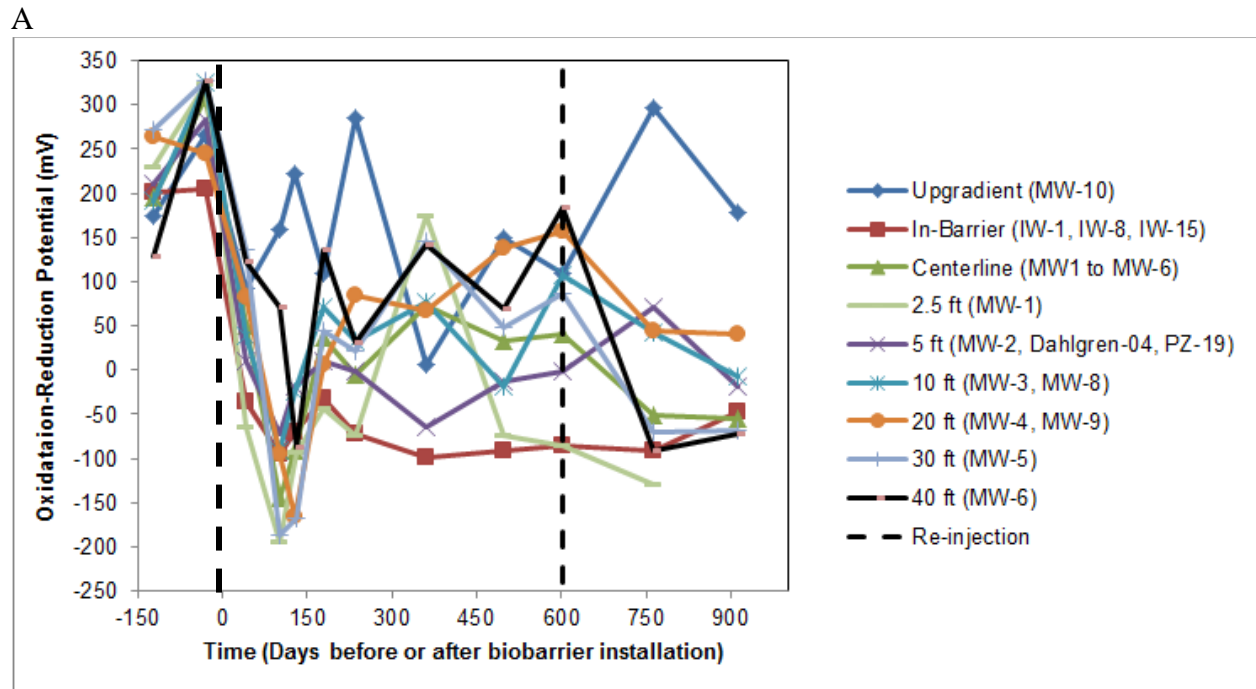

Figure 6.7. Oxidation-reduction potential over time in the demonstration plot.
 All wells are represented as a function of distance from the biobarrier in panel A and the upgradient, in-barrier, and centerline downgradient wells are represented in panel B.



6.1.3 pH

The groundwater in the aquifer was acidic before the demonstration, with an average pH within the test plot of 4.6 ± 0.4 S.U. ($n = 31$). Groundwater in upgradient monitoring MW-10, which was not impacted by the emulsified oil and buffer injection, remained acidic during the demonstration period, with an average pH of 4.6 ± 0.2 S.U. ($n = 12$). The pH along the centerline of the demonstration plot generally increased upon injection of the buffering agent along with the emulsified oil (**Figure 6.8**), as did the majority of the rest of the plot area (**Figure 6.9**). The in-barrier wells maintained a neutral pH value of 7.1 ± 1.2 S.U. ($n = 30$), while the centerline wells remained approximately one unit above the in situ pH for the duration of the demonstration (5.6 ± 0.7 S.U.; $n = 58$) (**Figure 6.9B**).

These data indicate that inclusion of the CoBupH slow release buffering agent during the barrier installation allowed elevation of the in situ pH to values that were conducive to perchlorate biodegradation (Wang *et al.*, 2008), and likely also lead to better RDX biodegradation than what would have occurred at lower pH values.

6.1.4 Total Organic Carbon (TOC)

The average TOC in the in situ groundwater was 2.4 ± 0.9 mg/L ($n = 32$), and the upgradient well remained in this range during the demonstration (2.0 ± 0.2 mg/L, $n = 12$). As expected, TOC was elevated, although quite variable, in the barrier (50 ± 60 mg/L, $n = 29$) and along the centerline (11 ± 18 mg/L, $n = 58$) during the demonstration after emulsified oil injection (**Figure 6.10**).

Spatial and temporal patterns in TOC can be seen in **Figure 6.11**. TOC rose and remain elevated in the in-barrier wells. The average TOC along the centerline also rose after the initial emulsified oil injection, but then decreased substantially to slightly above the upgradient concentrations prior to the second oil injection. As expected, a large increase in TOC was again observed after the second, more concentrated substrate injection in October, 2014. During the final sampling event in August, 2015, the TOC was elevated along the entire 40 ft length of centerline wells with an average concentration of 25.8 ± 21.7 mg/L ($n = 6$), with concentrations as high as 14 mg/L being observed 40 ft downgradient of the biobarrier.

Figure 6.8. Groundwater pH along the demonstration plot centerline.
Emulsified oil was re-injected after the October 2014 sampling event.

A

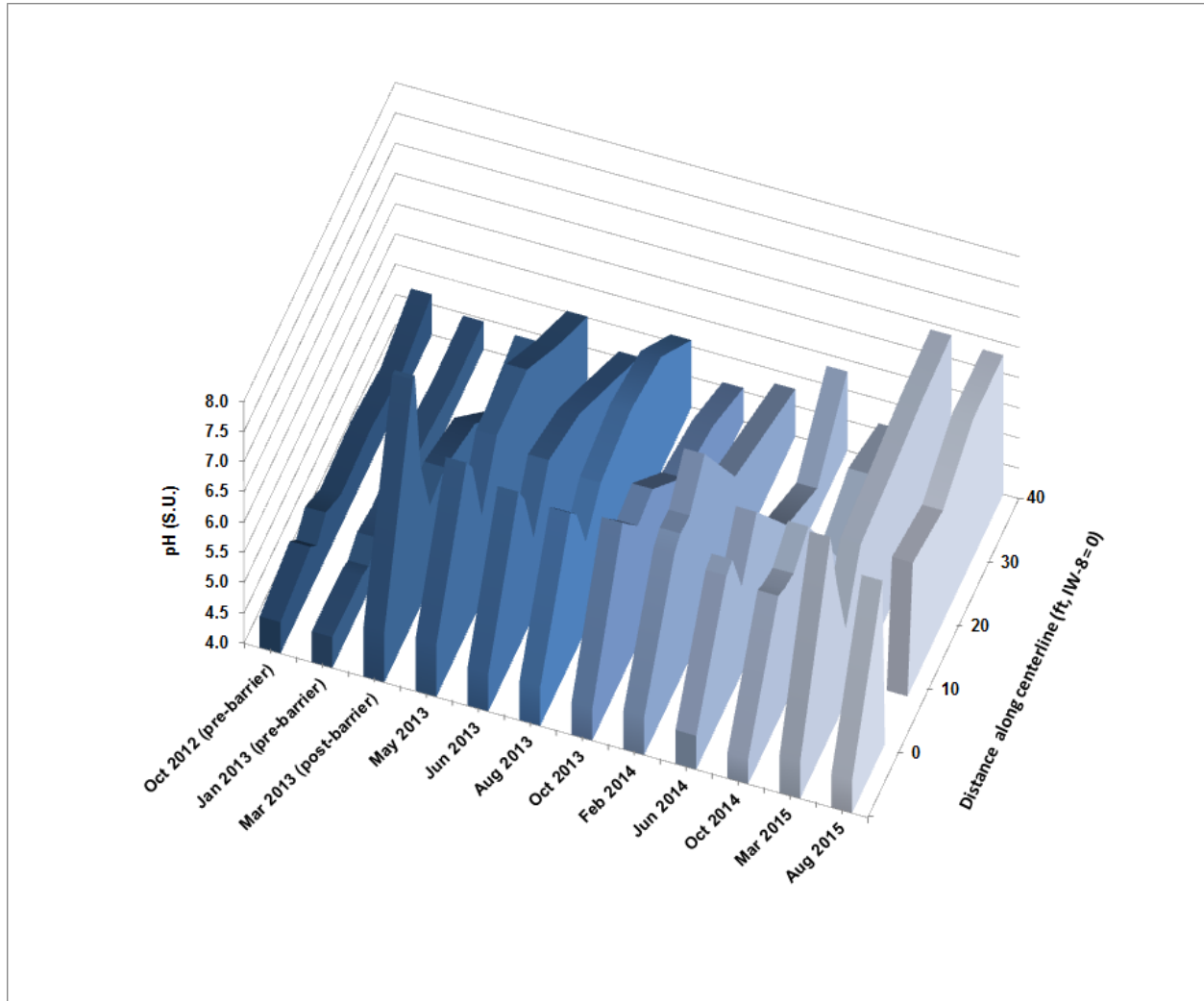

B

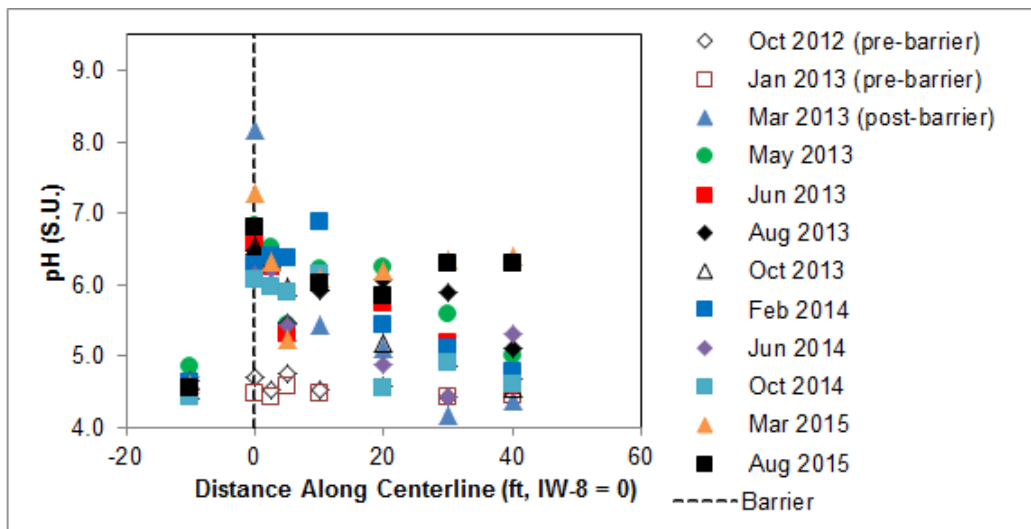

Figure 6.9. Groundwater pH over time in the demonstration plot.

All wells are represented as a function of distance from the biobarrier in panel A and the upgradient, in-barrier, and centerline downgradient wells are represented in panel B.

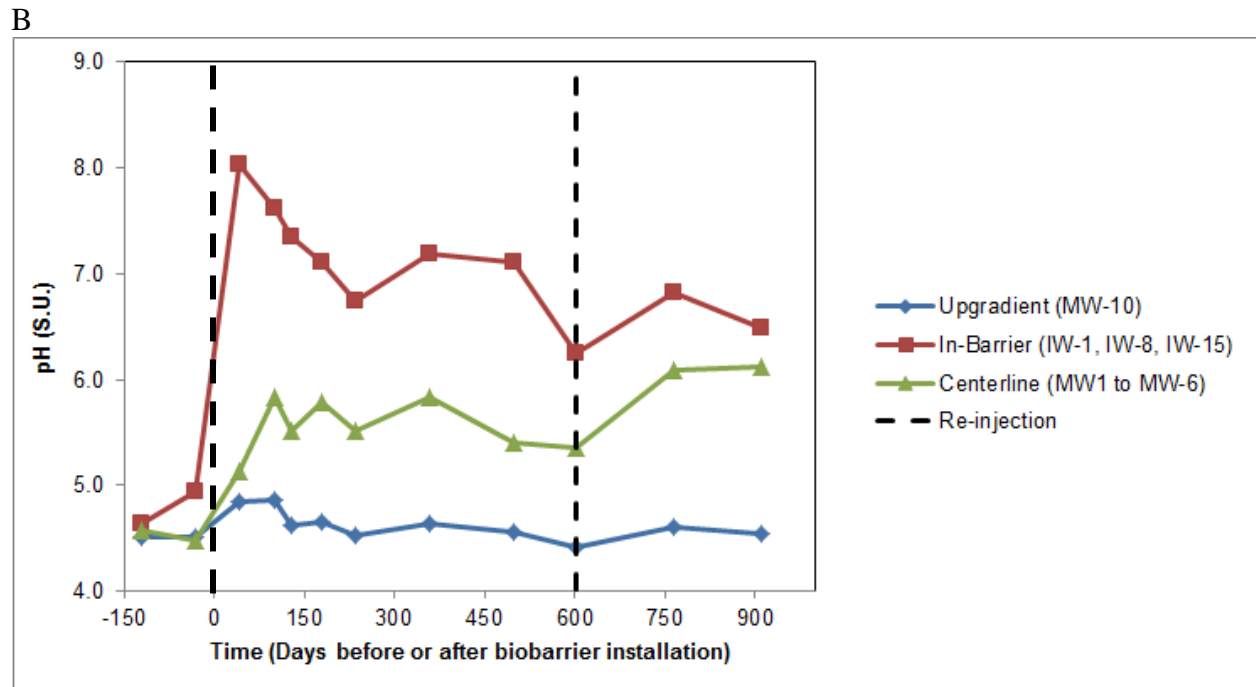
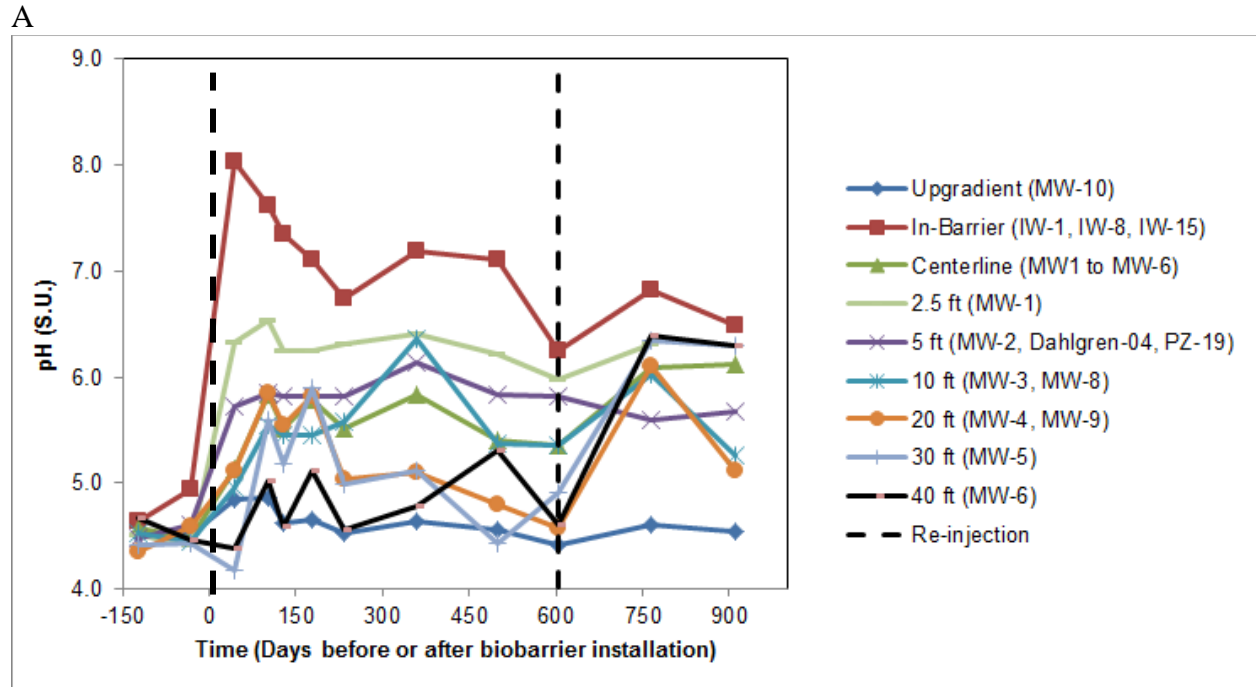
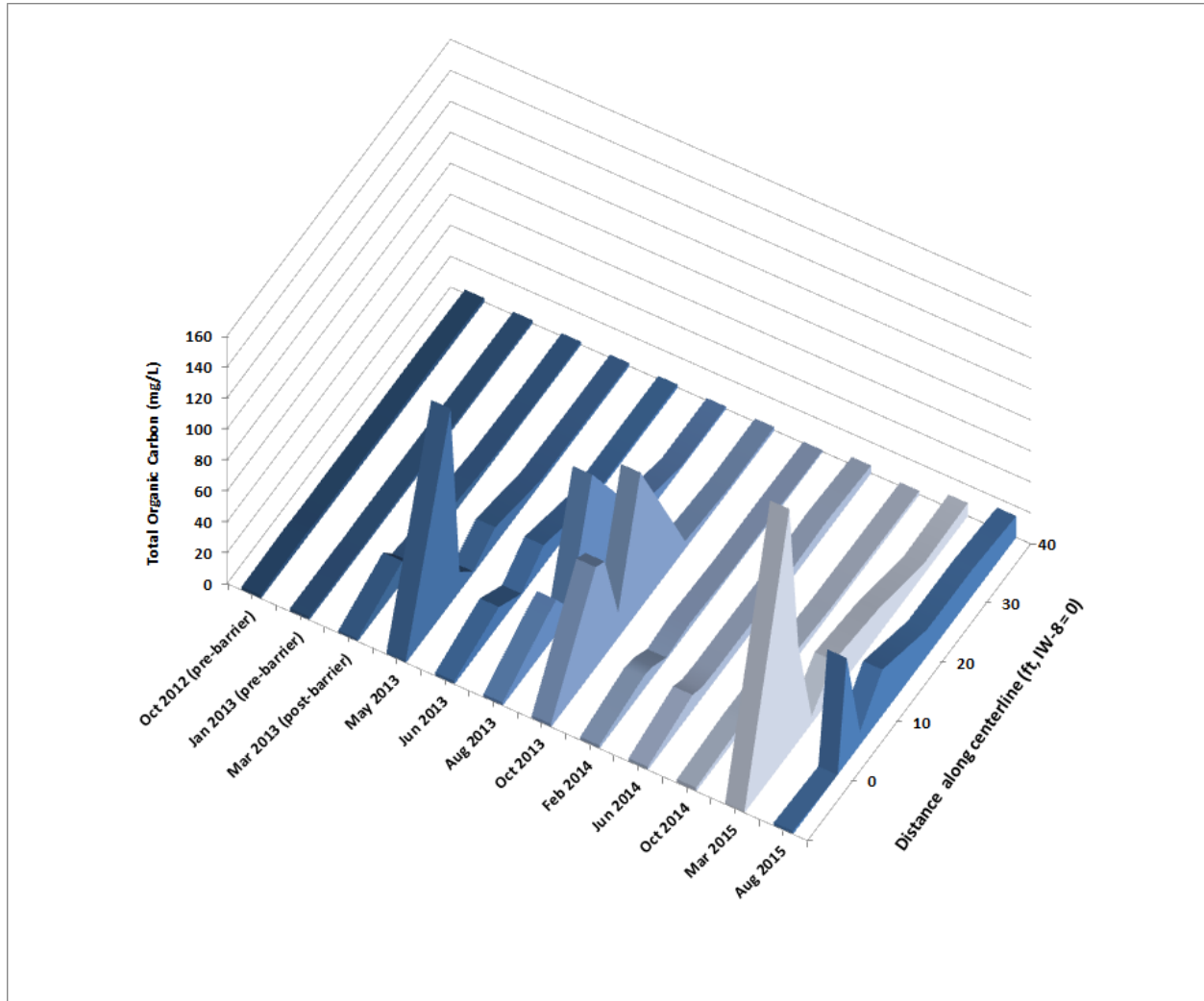

Figure 6.10. TOC in groundwater along the demonstration plot centerline.
Emulsified oil was re-injected after the October 2014 sampling event.

A



B

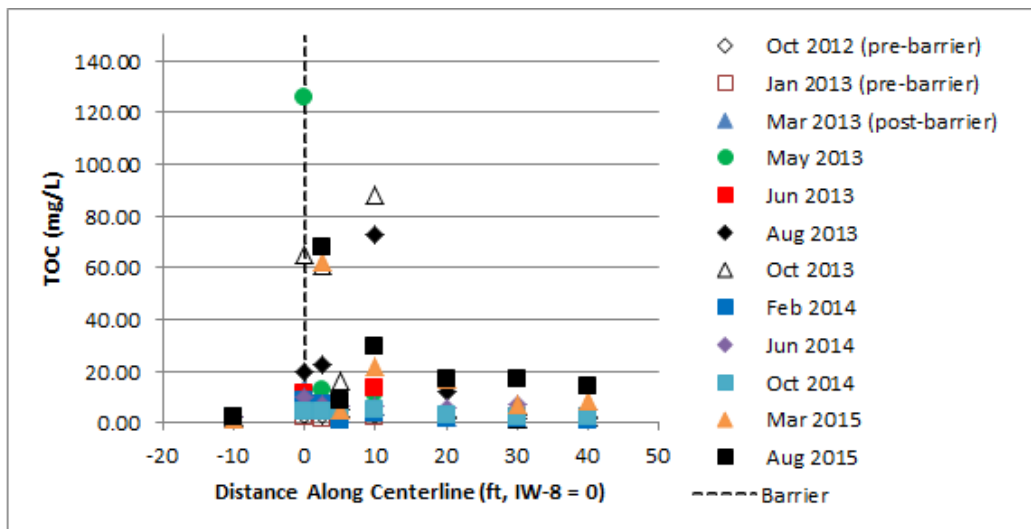
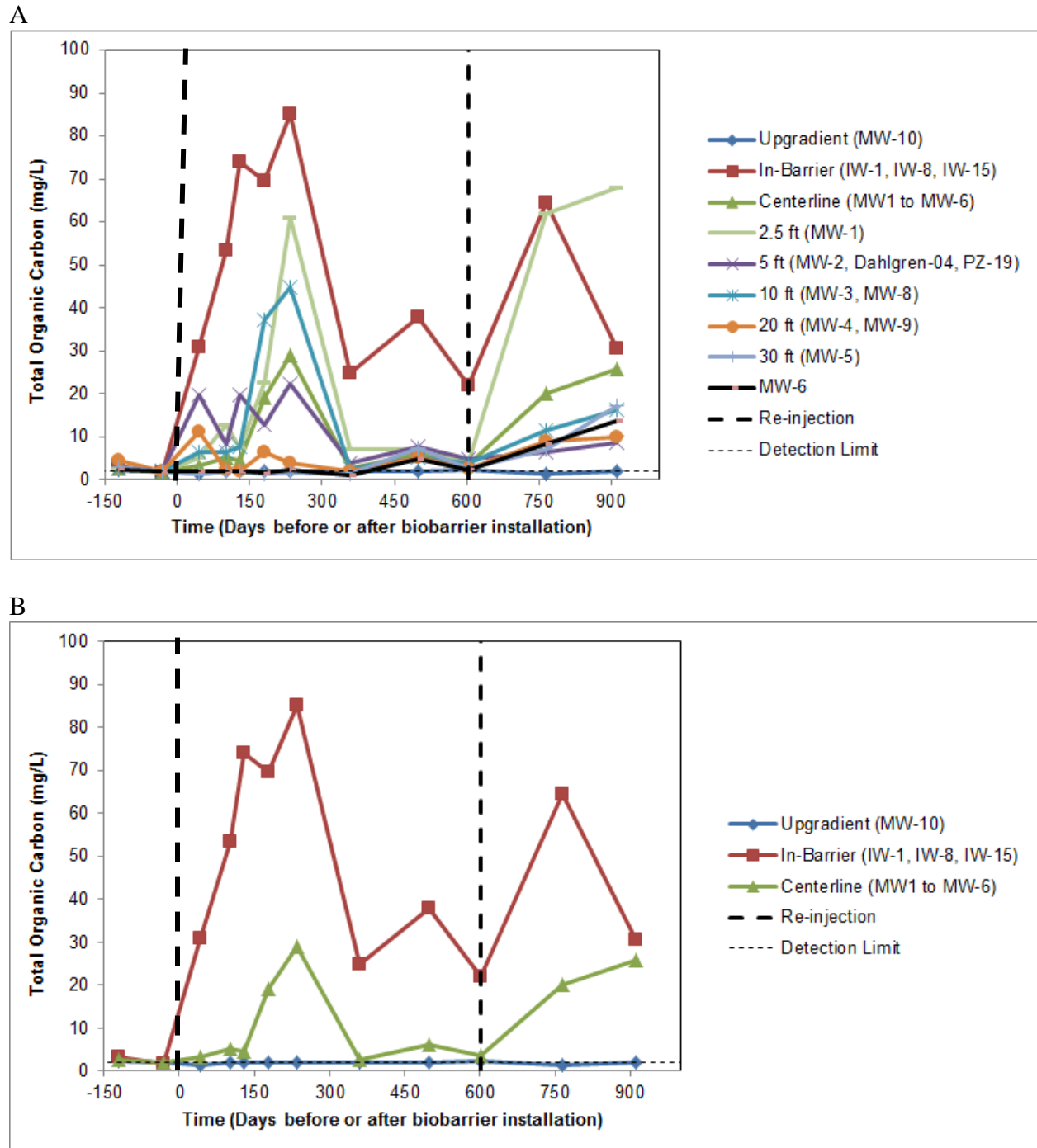

Figure 6.11. TOC in groundwater over time in the demonstration plot.

All wells are represented as a function of distance from the biobarrier in panel A and the upgradient, in-barrier, and centerline downgradient wells are represented in panel B.



6.1.5 Anions

The background concentrations of nitrate and sulfate in the groundwater averaged 3.2 ± 0.7 mg/L as N ($n = 32$) and 13.5 ± 5.2 mg/L ($n = 32$), respectively. The upgradient concentration of nitrate in MW-10 averaged 4.1 ± 1.2 mg/L as N ($n = 12$), while sulfate averaged 11.9 ± 3.3 mg/L ($n = 12$) over the course of the demonstration. The background nitrate concentration approximately doubled from 3.5 mg/L to around 7.0 mg/L over the duration of the demonstration, while the background sulfate appeared to exhibit annual increases and decreases. Neither nitrite nor phosphate were detected in any of the groundwater samples above the detection limit of 0.2 mg/L.

After emulsified oil injection, both nitrate and sulfate remained lower than background levels in the plot (**Figure 6.12**). In-barrier nitrate averaged 0.3 ± 0.4 mg/L ($n = 30$), and centerline nitrate averaged 0.7 ± 1.1 mg/L ($n = 58$). Corresponding sulfate values were more variable, with 4.5 ± 5.8 mg/L ($n = 30$) within the barrier, and 6.4 ± 5.4 mg/L ($n = 58$) along the centerline. The data plotted as a percent of the upgradient concentration are shown in **Figure 6.13**.

The nitrate and sulfate data provide additional evidence that both nitrate reducing and sulfate reducing conditions were generated within the plot due to the barrier installation. The data provide additional proof that reasonably good reducing conditions were generated. Biodegradation of both perchlorate and RDX are known to be inhibited by the presence of nitrate (Farhan and Hatzinger, 2009; Freedman and Sutherland, 1998).

6.1.6 Dissolved Gases

Site groundwater had no methane above the detection limit (<0.2 $\mu\text{g/L}$) before the injection of emulsified oil, and levels remained generally at or below detection at the upgradient well for the duration of the demonstration (2.0 ± 0.2 $\mu\text{g/L}$, $n = 12$). In contrast, methane levels rose dramatically along the centerline ~ 6 to 8 months after emulsified oil injection (**Figure 6.14**). Methane concentrations were temporally variable (**Figure 6.15**), with in-barrier concentrations averaging 2700 ± 3800 $\mu\text{g/L}$ ($n = 29$) and centerline concentrations averaging 1800 ± 2700 $\mu\text{g/L}$ ($n = 58$).

The detection of abundant methane indicated that strong reducing conditions were locally generated in the aquifer, even if DO and ORP readings suggested only mildly reducing or suboxic conditions. These data appear to be consistent with the aquifer heterogeneity, with layered clays and sands. The groundwater is likely collected primarily from the more porous sand layers intercepted by each well (probably less reducing due to infiltration of oxic rainwater in the shallow aquifer, etc.), but conditions and processes in the intervening clay layers may be much different (e.g., more reducing and contributing methane to the groundwater). Similar data were observed by Cozzarelli et al., (1999) (Cozzarelli *et al.*, 1999) in a gasoline-contaminated Coastal Plain aquifer. While strongly reducing conditions are not required for biodegradation of perchlorate and RDX, they may have provided reducing zones for ongoing contaminant removal even if the bulk aqueous phase was somewhat oxic. The large amount of methane detected also indicates that some of the emulsified oil was being “wasted” in terms of electron donor equivalents being used to produce methane versus degrading perchlorate and RDX. This is typical when a high TOC substrate is added to an aquifer.

Figure 6.12. Nitrate and sulfate concentrations in groundwater over time.

All wells are represented as a function of distance from the biobarrier in panel A & C and the upgradient, in-barrier, and centerline downgradient wells are represented in panel B & D.

A

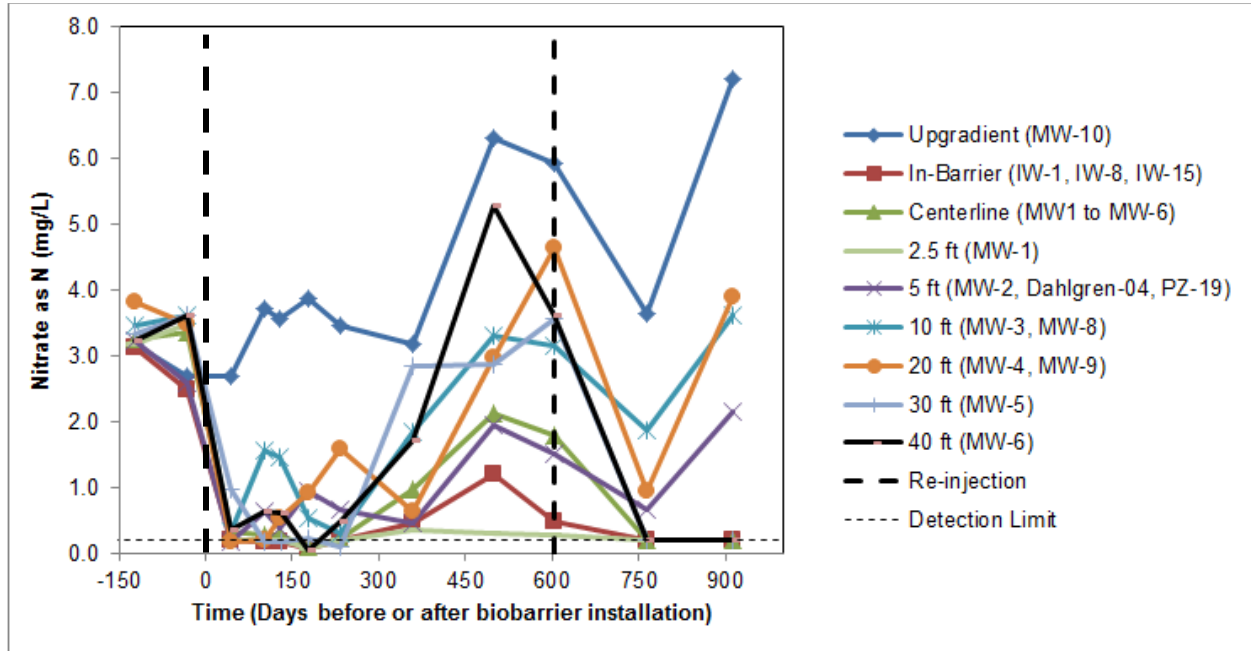

B

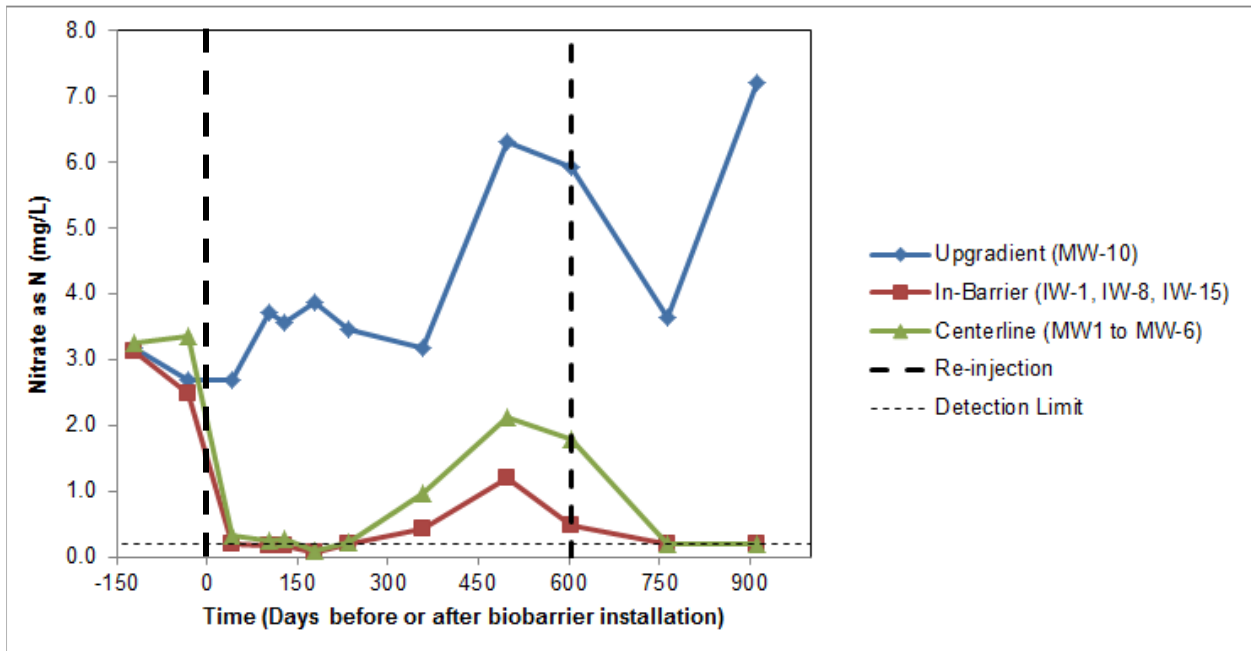
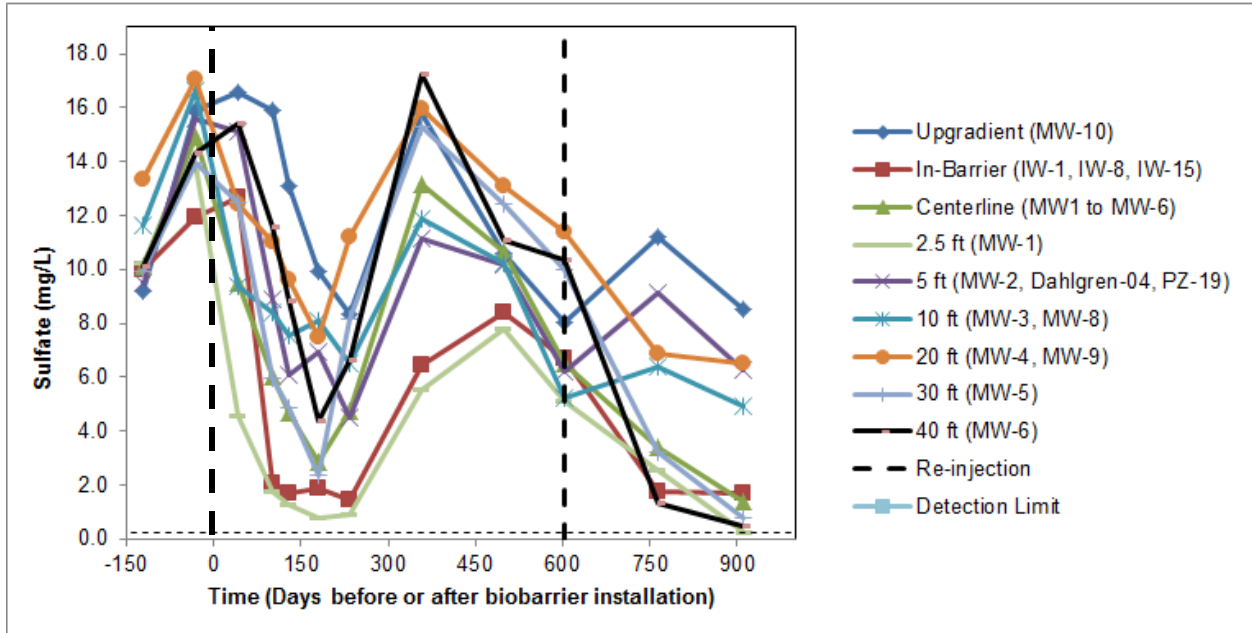

Figure 6.12 (cont.)

C



D

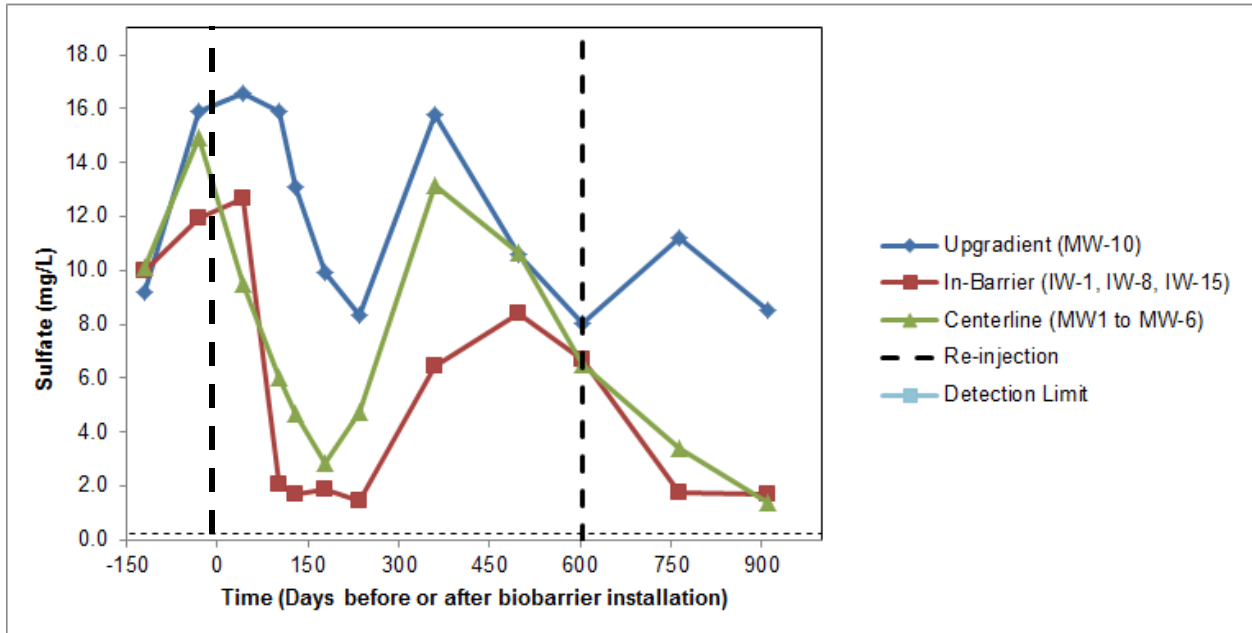
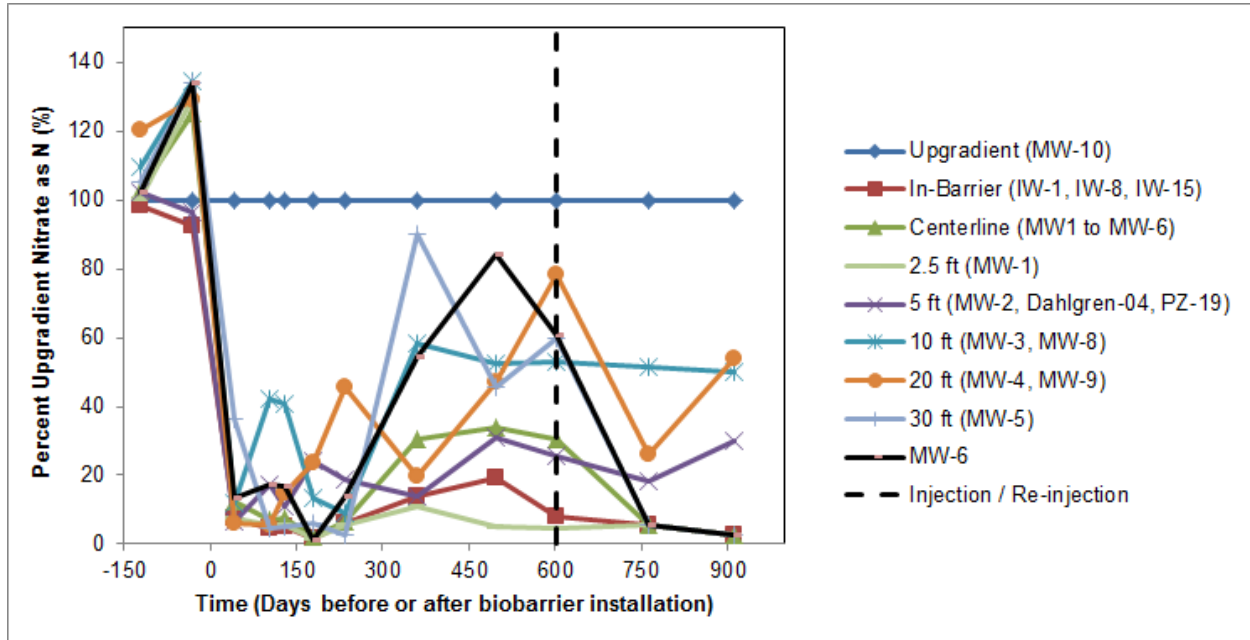

Figure 6.13. Nitrate and sulfate concentrations at various locations in the demonstration plot relative to the upgradient concentrations over time.

All wells are represented as a function of distance from the biobarrier in panel A & C and the upgradient, in-barrier, and centerline downgradient wells are represented in panel B & D.

A



B

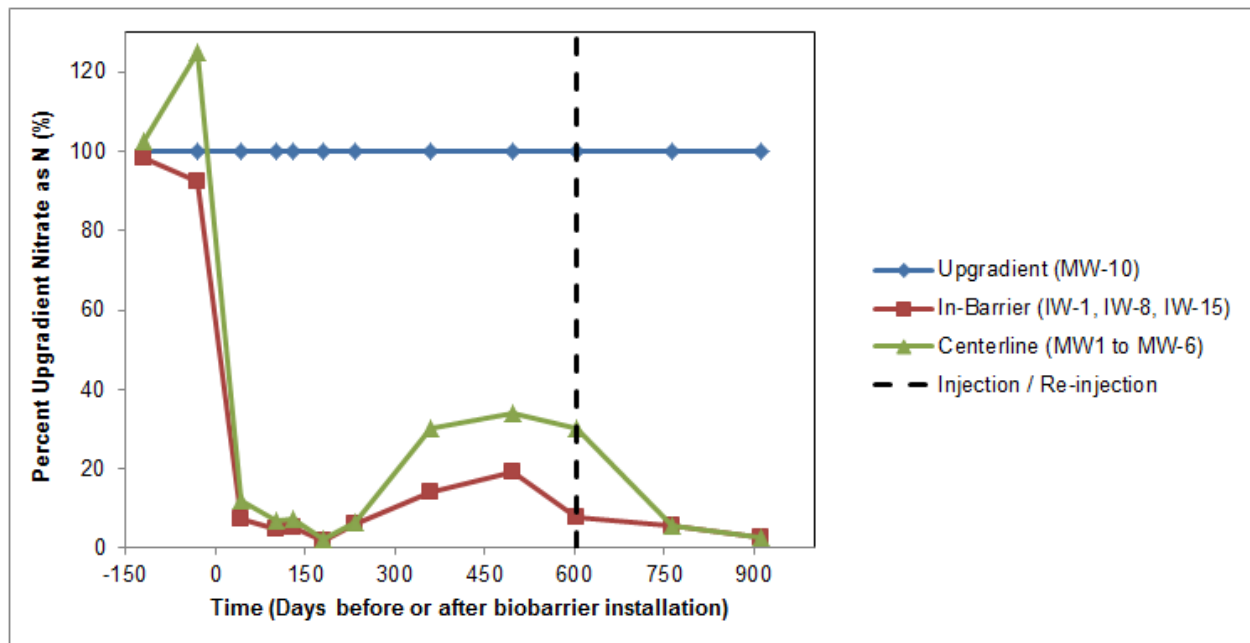
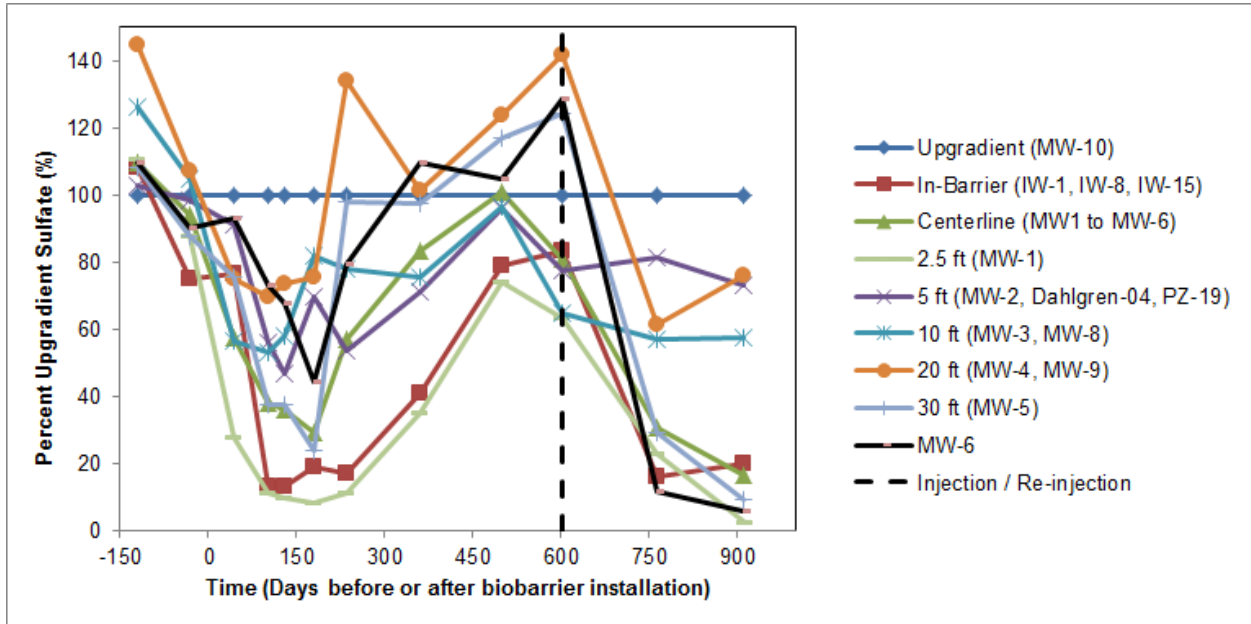

Figure 6.13 (cont.)

C



D

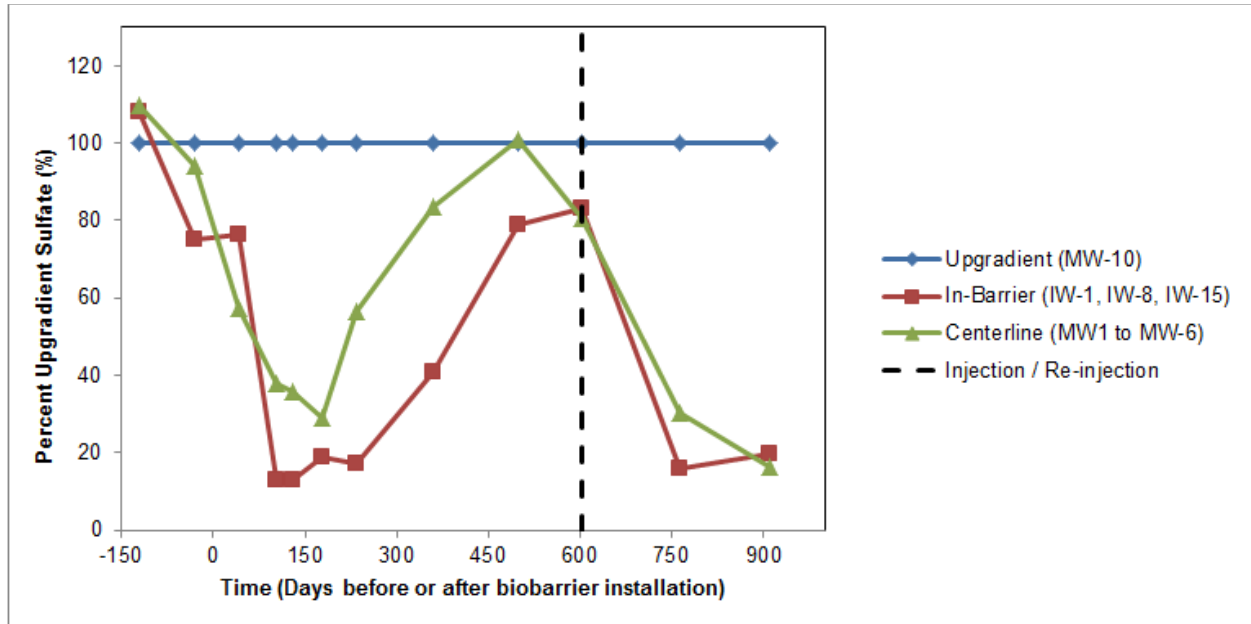
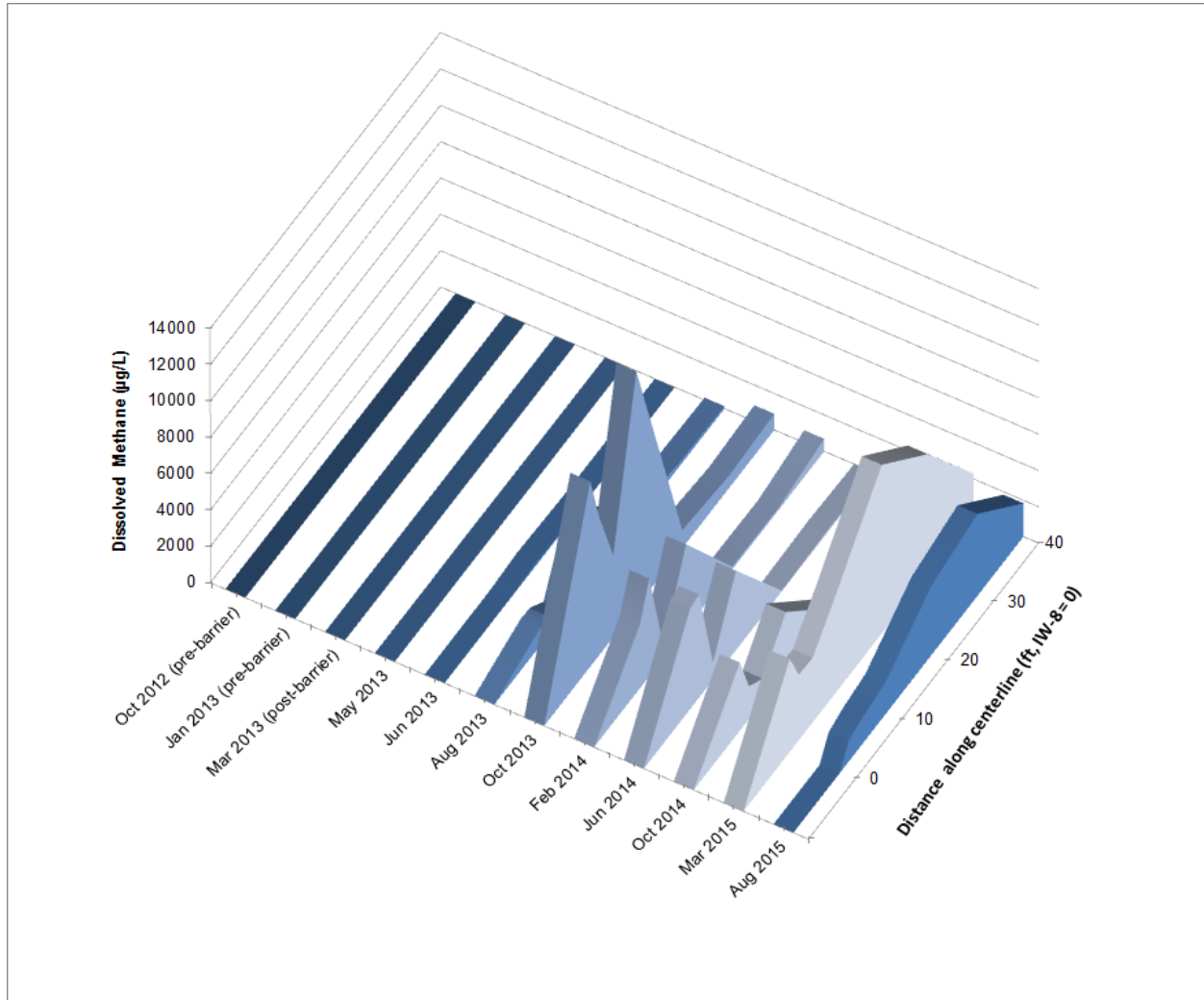

Figure 6.14. Dissolved methane along the centerline of the demonstration plot.
Emulsified oil was re-injected after the October 2015 sampling event.

A



B

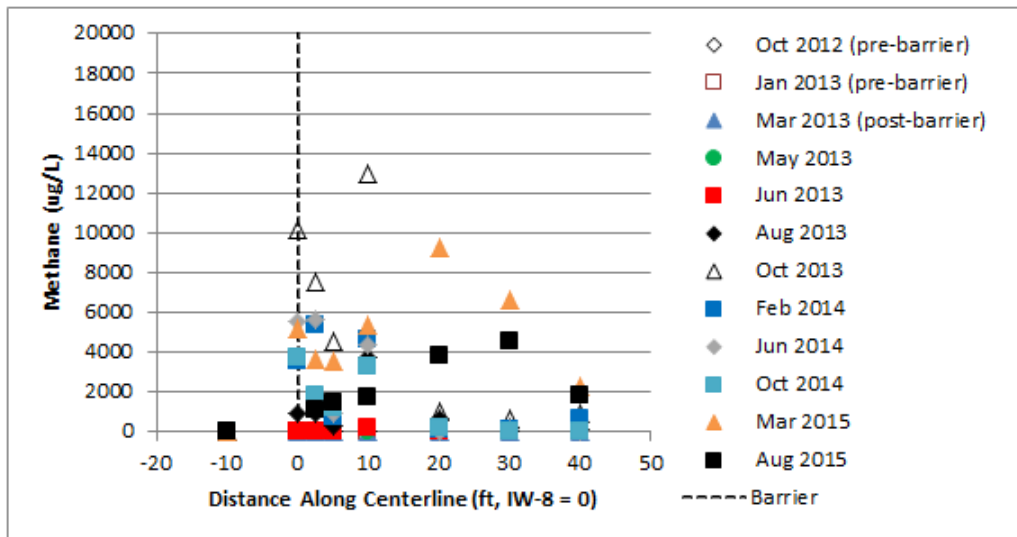
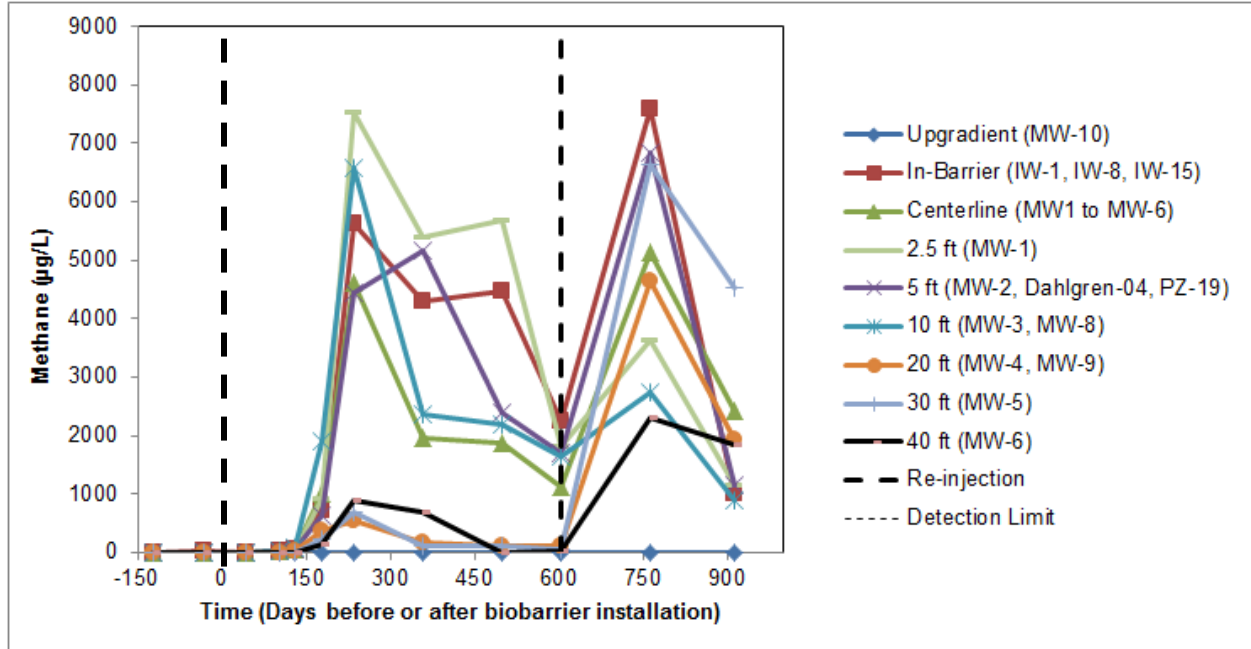

Figure 6.15. Dissolved methane concentrations groundwater over time.

All wells are represented as a function of distance from the biobarrier in panel A and the upgradient, in-barrier, and centerline downgradient wells are represented in panel B.

A



B

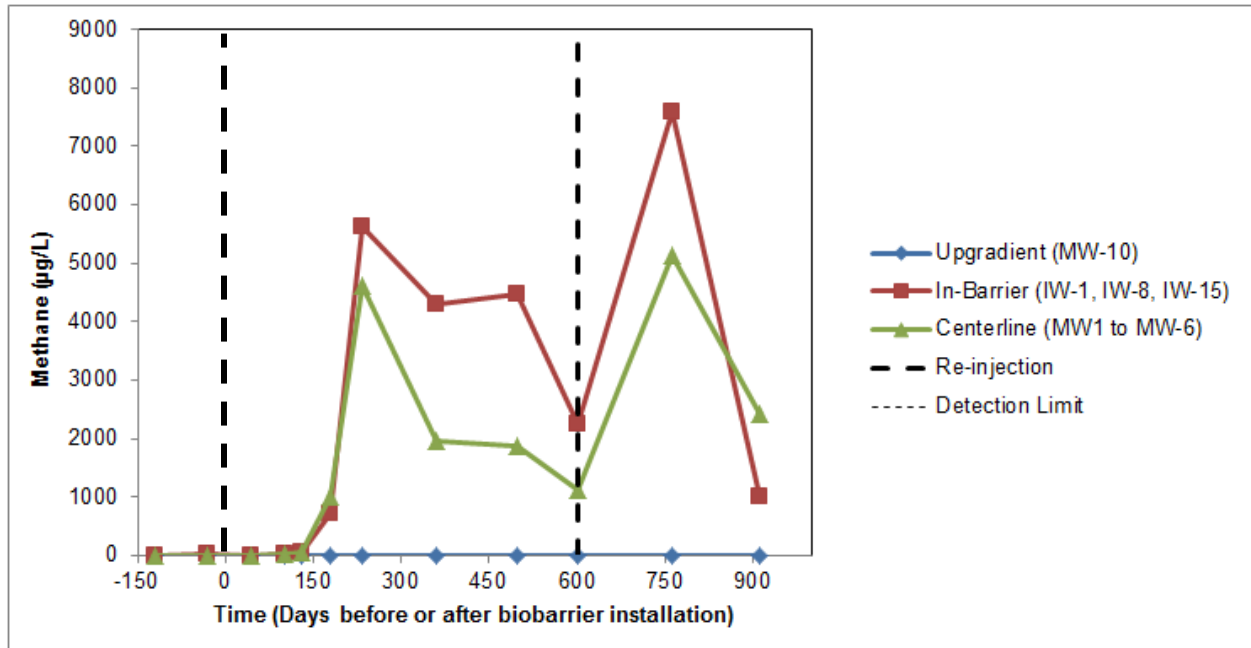

6.2 TARGET ANALYTES

The target analytes for this demonstration were the organic explosives RDX and HMX, and the inorganic oxidizer perchlorate. In addition, the concentrations of the primary RDX metabolites formed under anaerobic conditions – MNX, DNX, and TNX – were measured. Degradation rates for the target analytes were also calculated.

6.2.1 RDX, HMX, and metabolites

6.2.1.1 RDX and metabolite concentrations

No explosives (except RDX, RDX metabolites, and HMX) measurable by our modified EPA Method 8330 were detected at any time during the project above the detection limit (0.03 µg/L).

The concentration of RDX in the groundwater before the demonstration averaged 104 ± 29 µg/L ($n = 32$), and concentrations in the upgradient well remained in the same range for the duration of the study (105 ± 26 , $n = 12$). Concentrations of the RDX breakdown products MNX, DNX and TNX were <0.5 µg/L both before the emulsified oil injection and in the upgradient well for the duration of the demonstration.

Upon emulsified oil injection, RDX concentrations decreased significantly downgradient of the biobarrier (**Figure 6.16**), with a degradation “front” slowly moving down the centerline of the plot. A rebound in concentrations was observed before the second emulsified oil injection. The average in-barrier RDX concentration after emulsified oil injection was 15 ± 19 µg/L ($n = 30$), whereas the centerline concentration averaged 22 ± 24 µg/L ($n = 58$). RDX concentrations at various locations over time are presented in **Figure 6.17**, and the RDX concentrations relative to the upgradient well over time are presented in **Figure 6.18**.

The RDX removal averaged $83 \pm 17\%$ for the in-barrier wells and $75 \pm 21\%$ for the centerline wells from the first emulsified oil injection to the end of the demonstration. However, these averages include periods of time when the TOC from the emulsified oil injection(s) was depleted with a subsequent, and expected increase in RDX in downgradient wells. When TOC was present, and adequate time was allowed for degradation to occur, RDX concentrations reached extremely low levels in the centerline wells. For example, during October 2013, approximately 8 months after the initial oil injection, the RDX within the barrier to a distance of 30 ft downgradient ranged from <0.03 to 6 µg/L. RDX removal in these wells was $>94\%$. Similarly, in August, 2015, 10 months after the second emulsified oil injection, RDX concentrations along the centerline wells ranged from <0.03 µg/L (5/7 wells) to 2 µg/L (2 wells) as far as 40 ft downgradient of the barrier, with removal percentages $>98\%$ over this large distance. These data indicate this technology was highly effective for RDX removal when appropriate biogeochemical conditions were achieved in the aquifer.

The RDX metabolite concentrations over time are presented in **Figure 6.19** and **Figure 6.20**. As expected, MNX, DNX, and TNX increased as RDX degraded in response to the initial and secondary emulsified oil injections, and conversely decreased as RDX degradation slowed. The average concentration of MNX, DNX, and TNX within the barrier over the duration of the

demonstration averaged $2.7 \pm 3.6 \mu\text{g/L}$ ($n = 30$), $1.7 \pm 1.8 \mu\text{g/L}$ ($n = 30$), and $5.4 \pm 8.9 \mu\text{g/L}$ ($n = 30$), respectively. The corresponding values along the centerline were $2.6 \pm 3.2 \mu\text{g/L}$ ($n = 58$), $1.2 \pm 1.8 \mu\text{g/L}$ ($n = 58$), and $4.2 \pm 8.2 \mu\text{g/L}$ ($n = 58$), respectively. The trends indicate that the nitroso metabolites were being produced in measurable but clearly not stoichiometric concentrations, but were also being further transformed, degraded, or otherwise attenuated, and were therefore not expected to be present at any appreciable concentration further downgradient. To that end, during the final sampling event of the demonstration, in August, 2015, MNX, DNX and TNX were below detection ($<0.08 \mu\text{g/L}$) in 11 of the combined in-barrier and downgradient wells, and were present at a maximum of $1.1 \mu\text{g/L}$ in the remaining 4 wells that had detectable intermediates. The results therefore suggest that the RDX ring structure was being broken during biodegradation, leading to non-toxic and/or otherwise labile products (Crocker *et al.*, 2006; Halasz and Hawari, 2011).

6.2.1.2 RDX degradation rates

Pseudo-first order degradation rates were calculated using the estimated horizontal flow velocity in this area of approximately 0.059 ft/d (see section 5.2.2.4) to convert distance in the demonstration plot to residence or travel time. For instance, the first monitoring well, MW-1, was located 2.5 ft from the barrier. This equates to a 42 day residence time. For the in-barrier wells, a 2 ft zone of influence of the injected emulsified oil was assumed, resulting in a residence time of 34 days. The concentration difference between the upgradient well (MW-10) and each location within the plot at each timepoint was calculated ($\mu\text{g/L}$), and this value was divided by the residence time, resulting in a pseudo-first order degradation rate with units of $\mu\text{g/L/d}$.

Using the methodology described above, the RDX degradation rates over time were calculated and are presented in **Figure 6.21**. While the rates varied by location within the demonstration plot, they appeared to fluctuate within a moderately narrow range, especially in the latter half of the demonstration and in wells 5 ft or greater downgradient from the barrier. Rates increased significantly after the initial emulsified oil injection, and also after the second injection, although to a lesser degree and moreso in the wells closest to the barrier. The average degradation rate in the in-barrier wells was $2.5 \pm 1.1 \mu\text{g/L/d}$ ($n = 30$), while the average rate along the centerline was $0.4 \pm 0.4 \mu\text{g/L/d}$ ($n = 58$).

Given that most of the observed degradation occurred in close proximity to the barrier, rates were also calculated by line fitting the RDX decrease between upgradient well MW-10 and all three in-barrier monitoring wells. **Figure 6.22** presents exponential line fits using all the data collected after the initial emulsified oil injection. The x-axis is the residence time of 34 days based on a groundwater flow velocity of 0.059 ft/d and a groundwater travel distance of 2 ft within the biobarrier zone of influence. The best fit exponential line yields an RDX degradation rate of $0.13 /\text{d}$, or a calculated half-life of 5 days.

The most relevant comparison to this demonstration was a passive mulch biowall evaluated for treatment of RDX at the Pueblo Chemical Depot (Newell, 2008). No rates were calculated, but greater than 93% removal was observed, down to concentrations below $0.5 \mu\text{g/L}$. These results are similar to those observed during this demonstration.

Two previous semi-passive anaerobic biostimulation demonstrations, one at the Picatinny Arsenal (using cheese whey as the electron donor) and one at the Nebraska Ordnance Plant (using acetate

as the electron donor) did not calculate RDX degradation rates, but reported >95% reductions in RDX concentration (Hatzinger and Lippincott, 2012; Wade *et al.*, 2010), and degradation to below 1 µg/L, again similar to this demonstration.

Anaerobic RDX biodegradation assessed via push pull testing yielded rates of approximately 10 to 20 fold higher at the Umatilla Chemical Depot (0.7 to 1.1 /d), albeit much more labile fructose was used as the electron donor (Michalsen, 2015; Michalsen *et al.*, 2013). This type of approach would not be viable on an active range due to the rapid consumption of this soluble substrate and necessity for frequent reinjection.

6.2.1.3 HMX concentrations

The concentration of HMX in the groundwater before the demonstration averaged 15 ± 5 µg/L (n = 32), and concentrations in the upgradient well remained in the same range for the duration of the study (17 ± 3 µg/L, n = 12). HMX concentrations decreased significantly downgradient of the biobarrier after emulsified oil injection (**Figure 6.23**), with a degradation “front” slowly moving down the centerline of the plot. A rebound in concentrations was observed before the second emulsified oil injection. The average in-barrier HMX concentration after emulsified oil injection was 3 ± 3 µg/L (n = 30), whereas the centerline concentration averaged 6 ± 5 µg/L (n = 58). HMX concentrations at various locations over time are presented in **Figure 6.24**, and the HMX concentrations relative to the upgradient well over time are presented in **Figure 6.25**.

HMX removal was slightly lower than RDX removal, averaging $77 \pm 20\%$ for the in-barrier wells and $61 \pm 32\%$ for the centerline wells from the first emulsified oil injection to the end of the demonstration. However, as noted for RDX, during periods with sufficient TOC, low HMX concentrations were achieved in the centerline wells. For example, during August 2013, approximately 6 months after the initial oil injection, the HMX within the barrier to a distance of 40 ft downgradient ranged from <0.03 to 4 µg/L with an average of 1.2 µg/L. Similarly, in August, 2015, 10 months after the second emulsified oil injection, HMX concentrations along the centerline wells ranged from <0.03 µg/L (6/7 wells) to 2 µg/L (1 well) as far as 40 ft downgradient of the barrier. These data indicate this technology was also highly effective for HMX removal, when appropriate biogeochemical conditions were achieved in the aquifer.

6.2.1.4 HMX degradation rates

The same methodology as was used for RDX was employed to determine pseudo-first order degradation rates for HMX. The HMX degradation rates over time are presented in **Figure 6.26**. As with RDX, the rates varied by location within the demonstration plot, but fluctuated within a moderately narrow range. Rates increased in response to the emulsified oil injections. The average degradation rate in the in-barrier wells was 0.4 ± 0.2 µg/L/d (n = 30), while the average rate along the centerline was 0.1 ± 0.1 µg/L/d (n = 58). Taking the average rates from all wells downgradient from MW-10 yields an HMX degradation rate of 0.1 ± 0.2 µg/L/d (n = 148).

Curve fitting the upgradient and in-barrier well data lead to an HMX degradation rate of 0.09 /d (**Figure 6.27**), or a calculated half-life of 8 days.

Comparable performance for HMX treatment was observed using the passive mulch biowall at the Pueblo Chemical Depot (Newell, 2008) and semi-passive anaerobic biostimulation at the Picatinny

Arsenal cited above (Hatzinger and Lippincott, 2012; Wade *et al.*, 2010). Degradation rates and/or half-lives were not calculated in these previous studies.

6.2.2 Perchlorate

6.2.2.1 Perchlorate concentrations

The concentration of perchlorate in the groundwater before the demonstration averaged 36 ± 11 $\mu\text{g/L}$ ($n = 32$), and concentrations in the upgradient well remained in the same range for the duration of the study (34 ± 5 $\mu\text{g/L}$, $n = 12$). The first injection of emulsified oil resulted in rapid decreases in perchlorate concentrations downgradient of the biobarrier (**Figure 6.28**). Concentrations increased somewhat before the second emulsified oil injection. The average in-barrier perchlorate concentration after emulsified oil injection was 3 ± 4 $\mu\text{g/L}$ ($n = 30$), whereas the centerline concentration averaged 9 ± 12 $\mu\text{g/L}$ ($n = 58$). Perchlorate concentrations at various locations over time are presented in **Figure 6.29**, and the perchlorate concentrations relative to the upgradient well over time are presented in **Figure 6.30**.

Perchlorate removal was greater than both RDX and HMX, with $91 \pm 9\%$ removal in the barrier wells, and was comparable to total RDX removal along the centerline at $76 \pm 21\%$ from the first emulsified oil injection to the end of the demonstration. During periods with sufficient TOC, low perchlorate concentrations were achieved in the centerline wells. For example, during August 2013, approximately 6 months after the initial oil injection, the perchlorate within the barrier to a distance of 40 ft downgradient ranged from <0.5 (4 wells) to 17.2 $\mu\text{g/L}$ (1 well) with an average of 3.2 $\mu\text{g/L}$. Similarly, in August, 2015, 10 months after the second emulsified oil injection, perchlorate concentrations along the centerline wells ranged from <0.5 $\mu\text{g/L}$ (5/7 wells) to 2.2 $\mu\text{g/L}$ (1 well) as far as 40 ft downgradient of the barrier, with an average concentration of 0.9 $\mu\text{g/L}$. These results demonstrate that this passive biobarrier approach is highly effective for removal of both perchlorate and nitramine explosives, when appropriate biogeochemical conditions were achieved in the aquifer.

6.2.2.2 Perchlorate degradation rates

The same methodology as was used for RDX and HMX was employed to determine pseudo-first order degradation rates for perchlorate. The perchlorate degradation rates over time are presented in **Figure 6.31**. Perchlorate degradation rates increased after the initial emulsified oil injection, but did not seem to be appreciably affected by the second injection. The average degradation rate in the in-barrier wells was 1 ± 0.2 $\mu\text{g/L/d}$ ($n = 30$), while the average rate along the centerline was 0.2 ± 0.2 $\mu\text{g/L/d}$ ($n = 58$). The average rates from all downgradient wells was 0.3 ± 0.4 $\mu\text{g/L/d}$ ($n = 148$). Exponential curve fitting yielded an estimated perchlorate degradation rate of 0.098 /d (**Figure 6.32**), or a calculated half-life of 7 days.

Emulsified oil in a permeable reactive barrier was examined previously for emulsified chlorinated solvents and perchlorate (Borden *et al.*, 2002). Removal greater than 95% was observed, but no rates were reported. Similarly, in situ anaerobic biostimulation for perchlorate was demonstrated at the Aerojet Superfund Site in Sacramento, CA (Geosyntech, 2002). A perchlorate half-life of 0.5 to 1.2 days was reported. The shorter half-life compared to our demonstration may reflect the use of ethanol as the electron donor, compared to emulsified oil in the present demonstration. Anaerobic biostimulation was also demonstrated at Aerojet General Corporation using citrate as

the electron donor (Hatzinger and Diebold, 2009). No rates were reported, but removal of approximately 89% of the perchlorate was observed in the treatment area, very comparable to the passive emulsified oil biobarrier.

Figure 6.16. RDX along the centerline of the demonstration plot.
Emulsified oil was re-injected after the October 2014 sampling event.

A

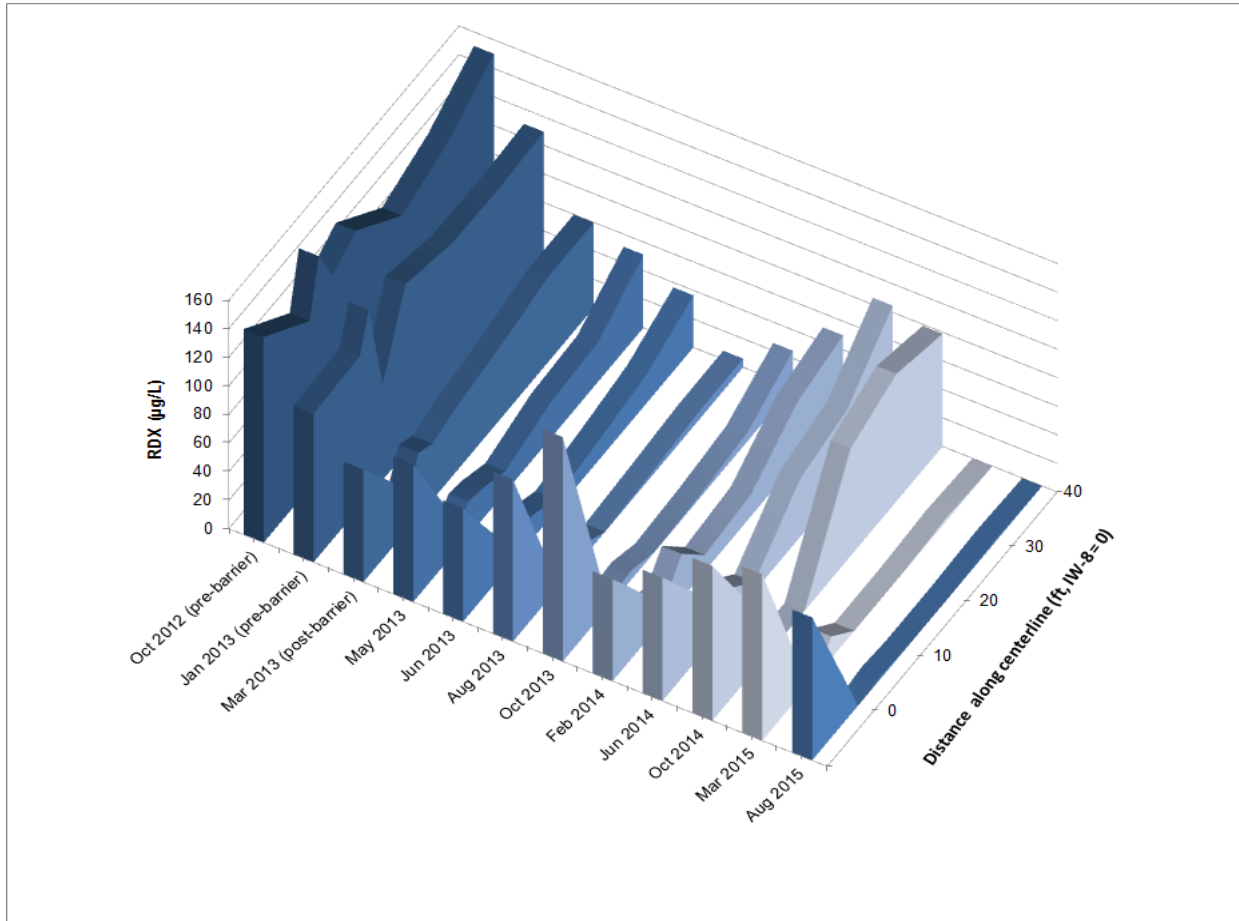

B

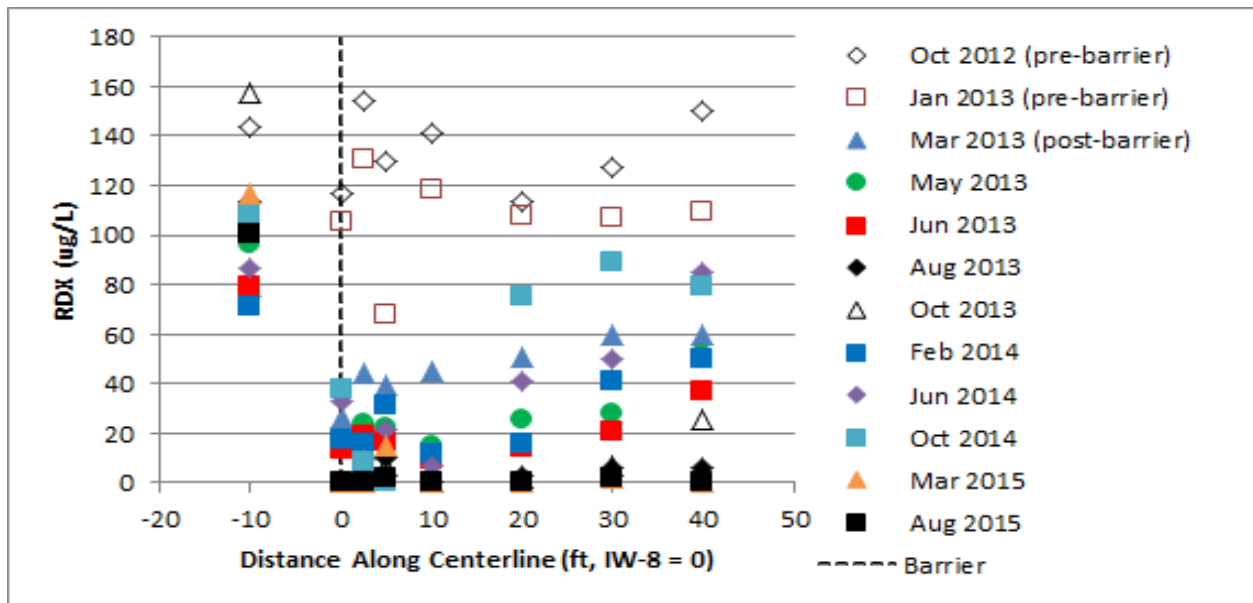
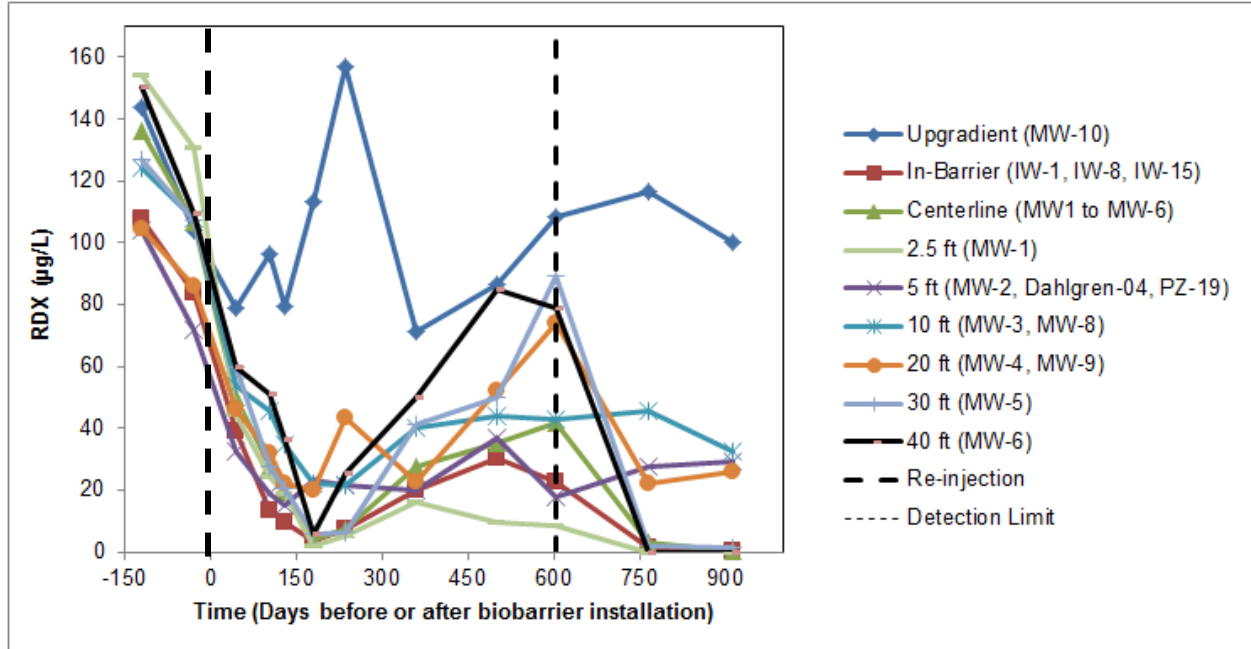

Figure 6.17. RDX concentrations groundwater over time.

All wells are represented as a function of distance from the biobarrier in panel A and the upgradient, in-barrier, and centerline downgradient wells are represented in panel B.

A



B

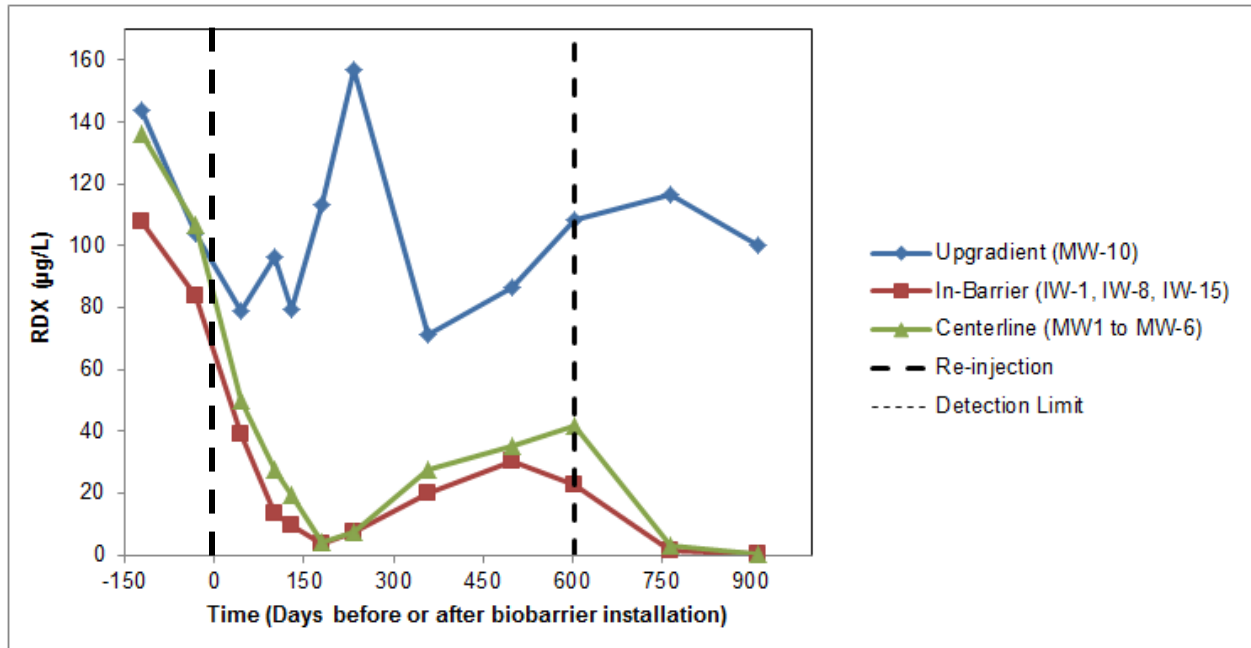
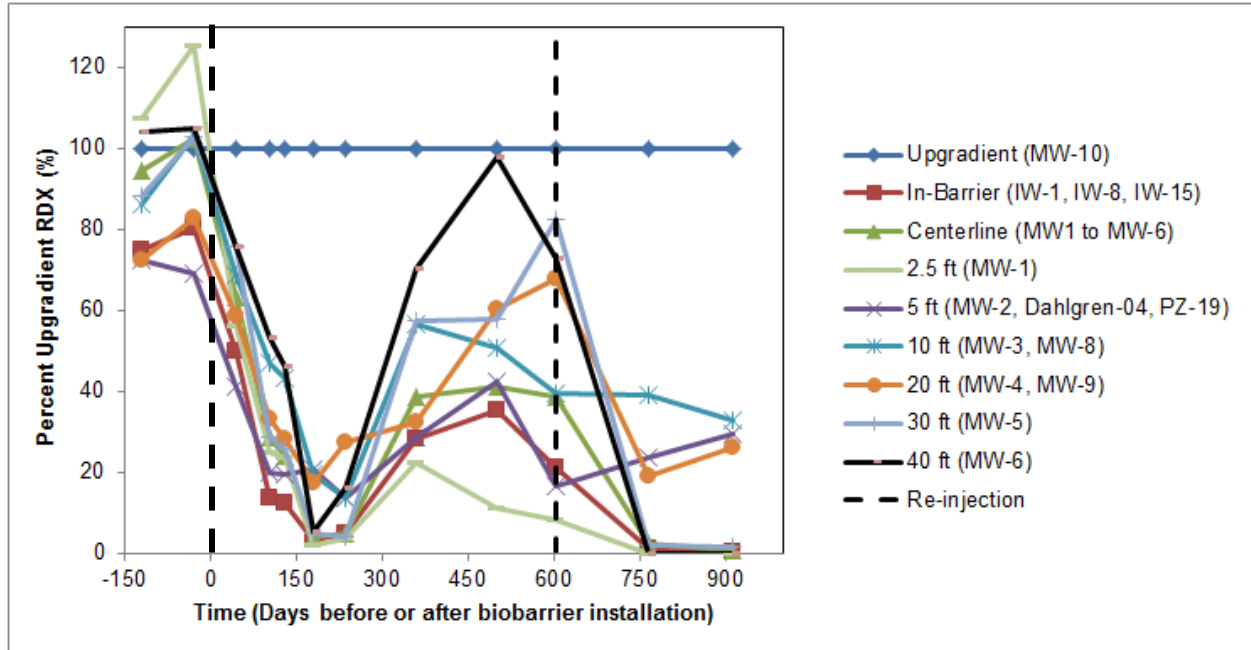

Figure 6.18. RDX concentrations at various locations in the demonstration plot relative to the upgradient concentrations over time.

All wells are represented as a function of distance from the biobarrier in panel A and the upgradient, in-barrier, and centerline downgradient wells are represented in panel B.

A



B

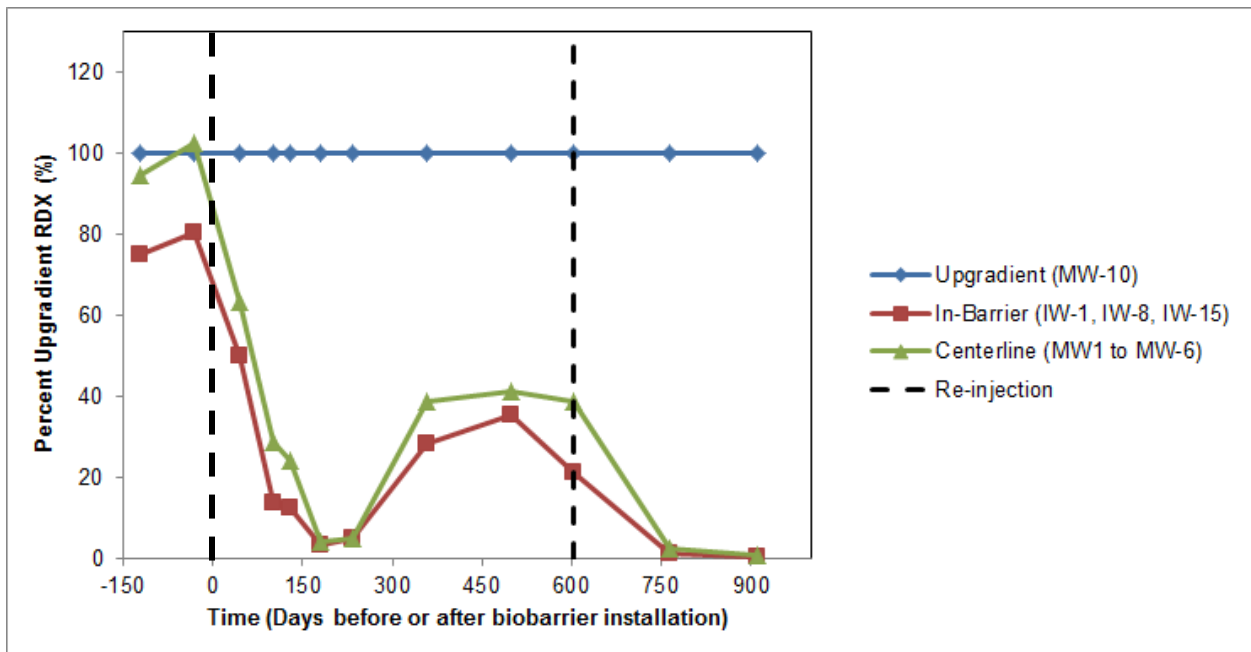

Figure 6.19. RDX metabolite concentrations groundwater over time at various locations.
 All wells are represented as a function of distance from the biobarrier.

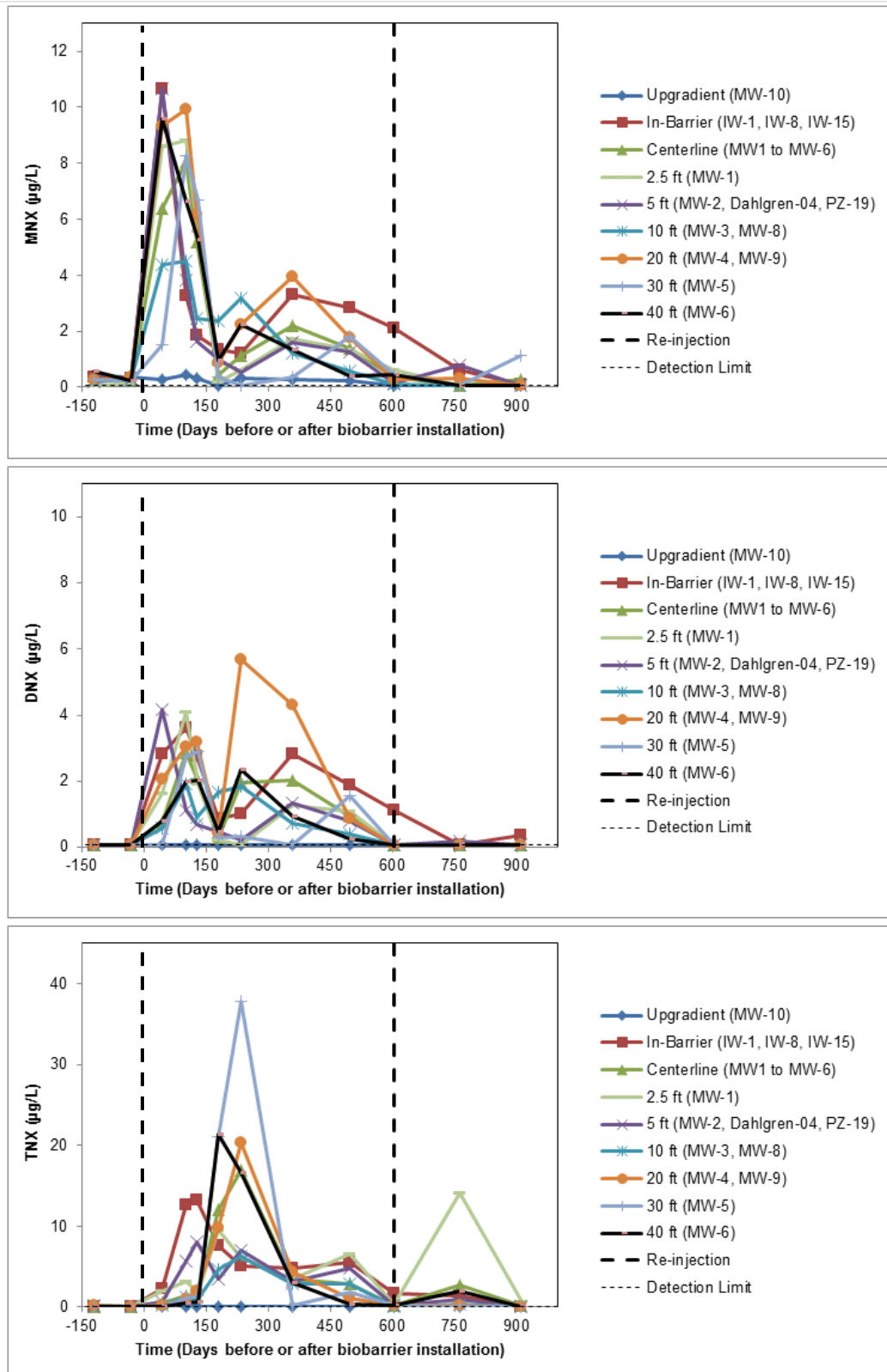

Figure 6.20. RDX metabolite concentrations groundwater over time in the barrier and along the centerline.

The upgradient, in-barrier, and centerline downgradient wells are represented.

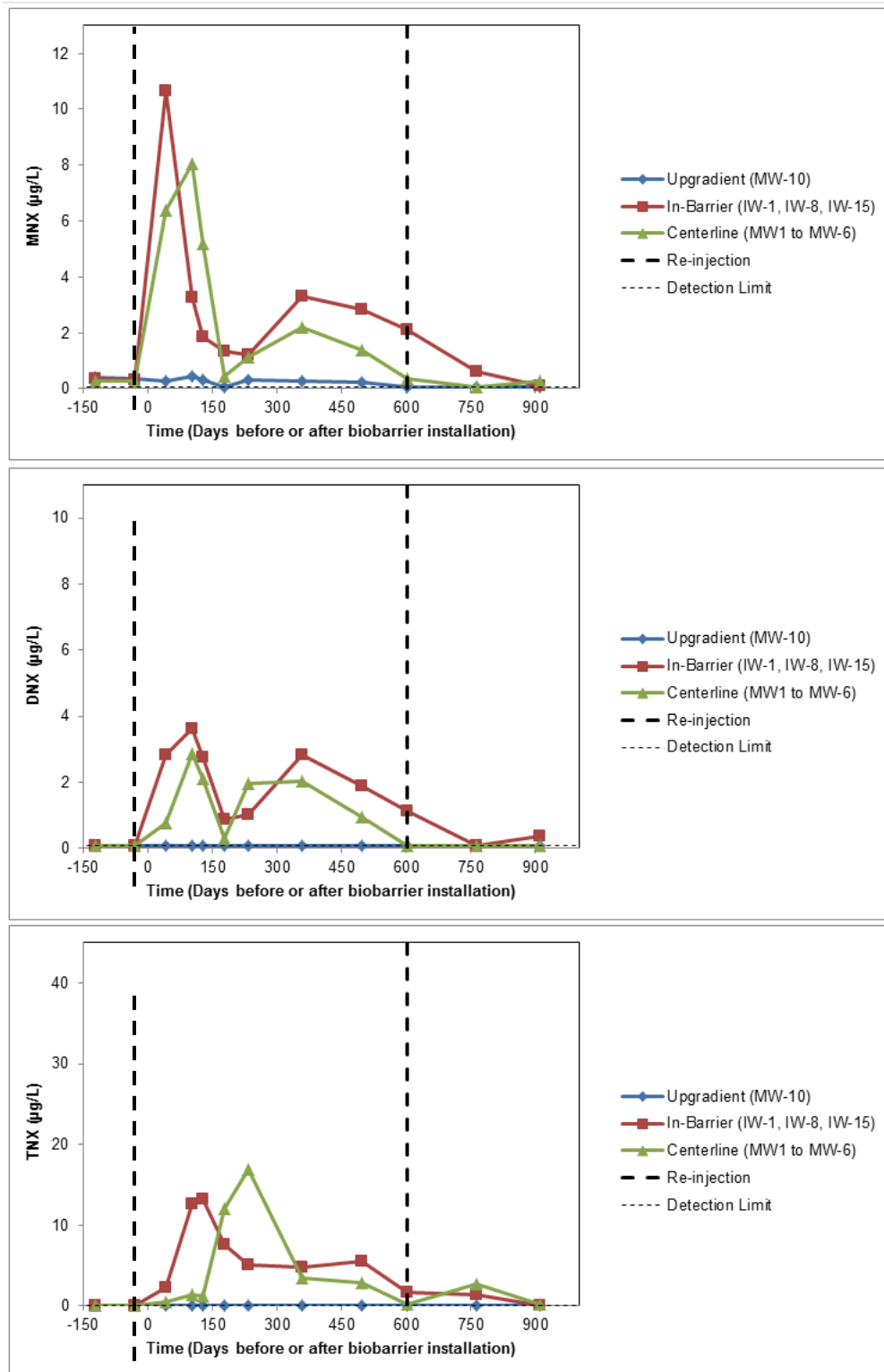
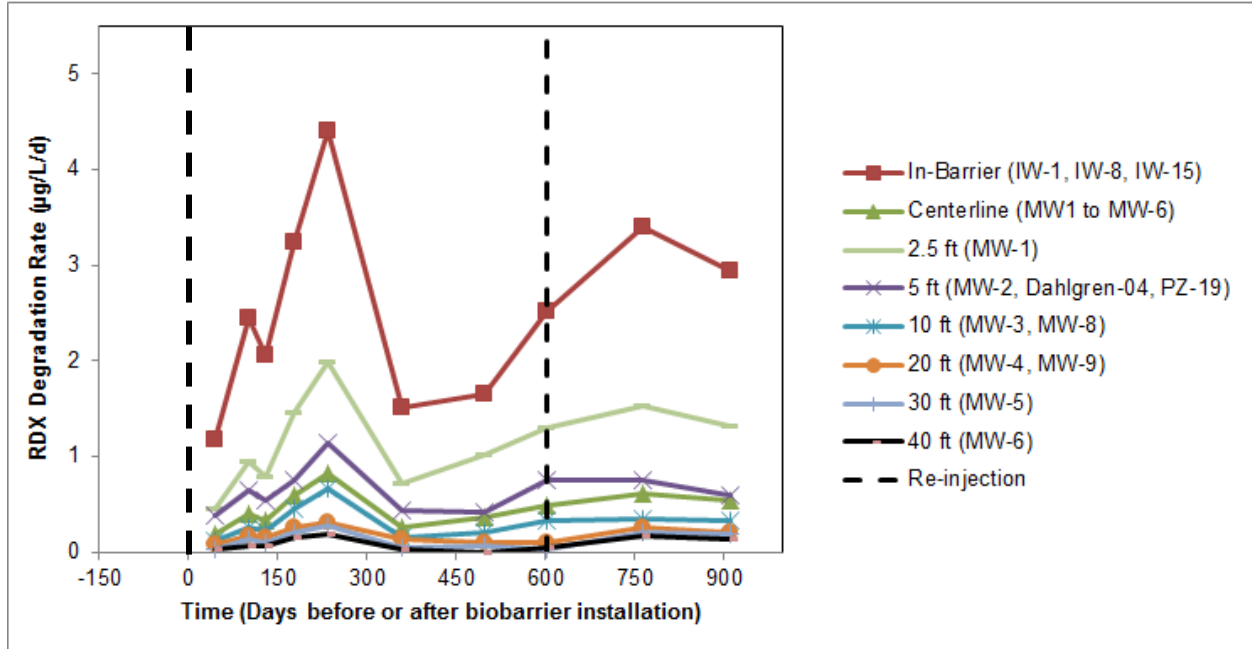

Figure 6.21. RDX degradation rates over time.

All wells are represented as a function of distance from the biobarrier in panel A and the upgradient, in-barrier, and centerline downgradient wells are represented in panel B.

A



B

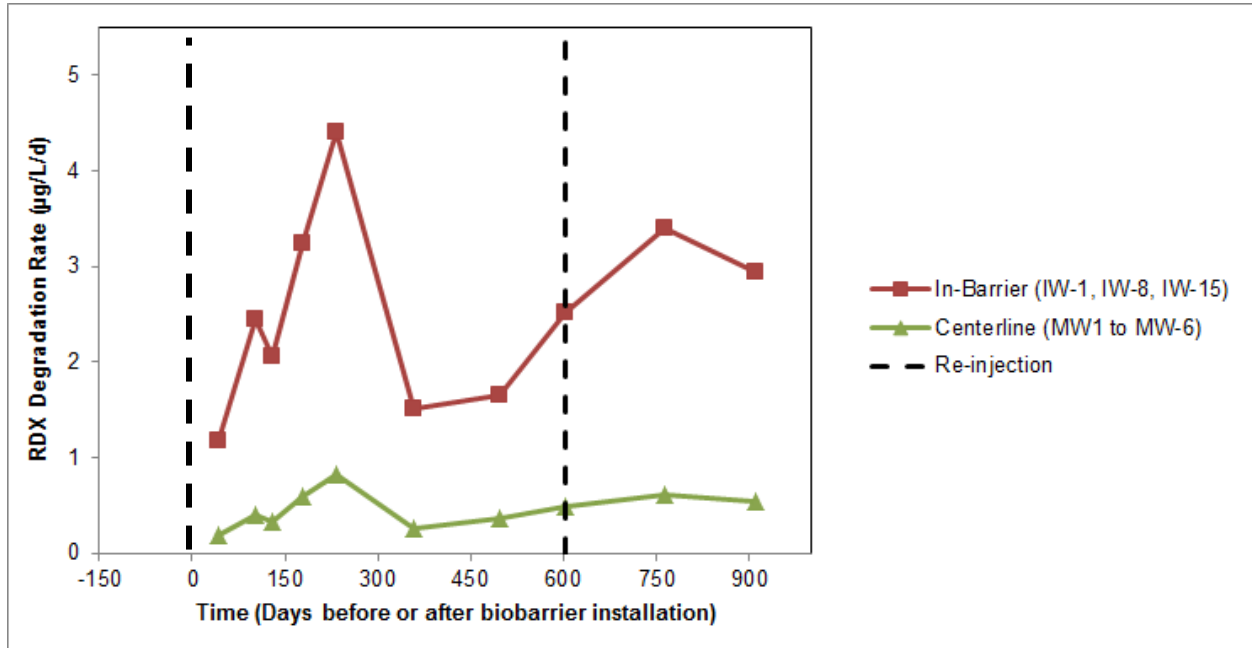

Figure 6.22. RDX degradation rate using data from upgradient well MW-10 versus all three in-barrier monitoring wells.

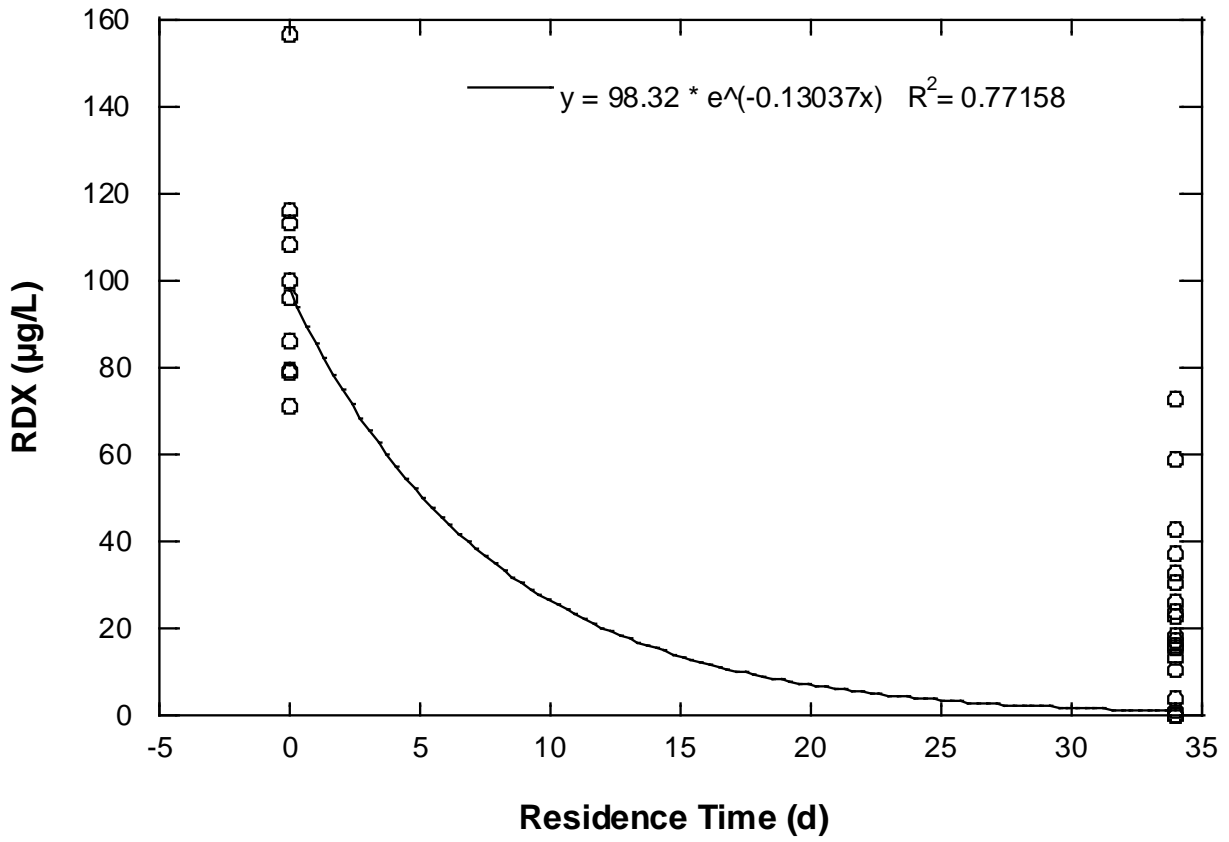
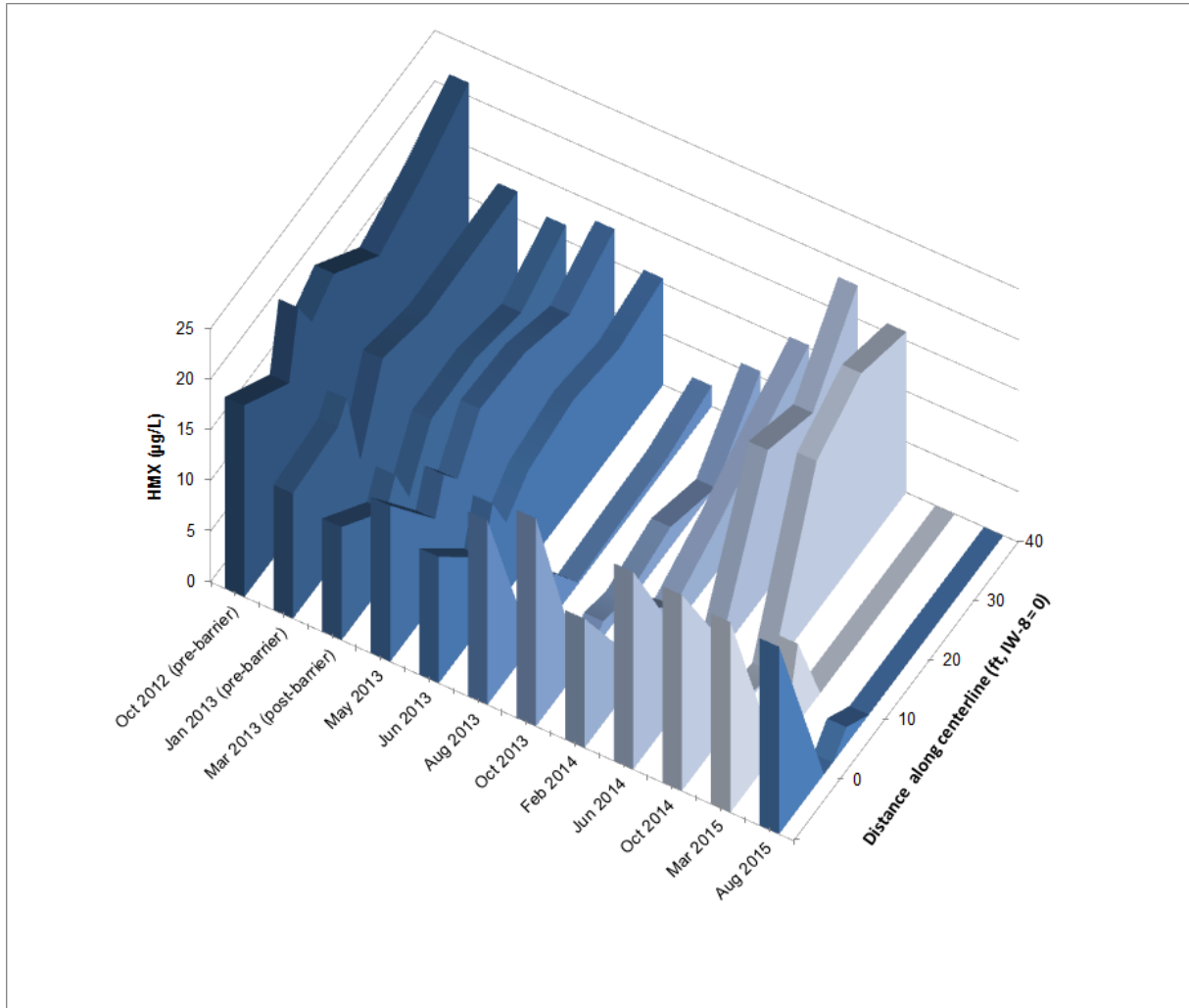

Figure 6.23. HMX along the centerline of the demonstration plot.
Emulsified oil was re-injected after the October 2014 sampling event.

A



B

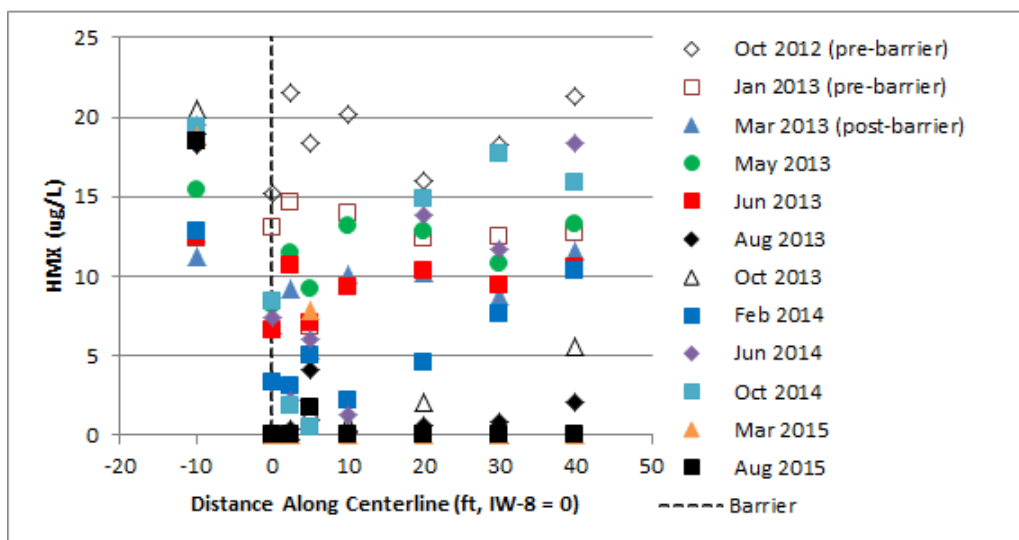
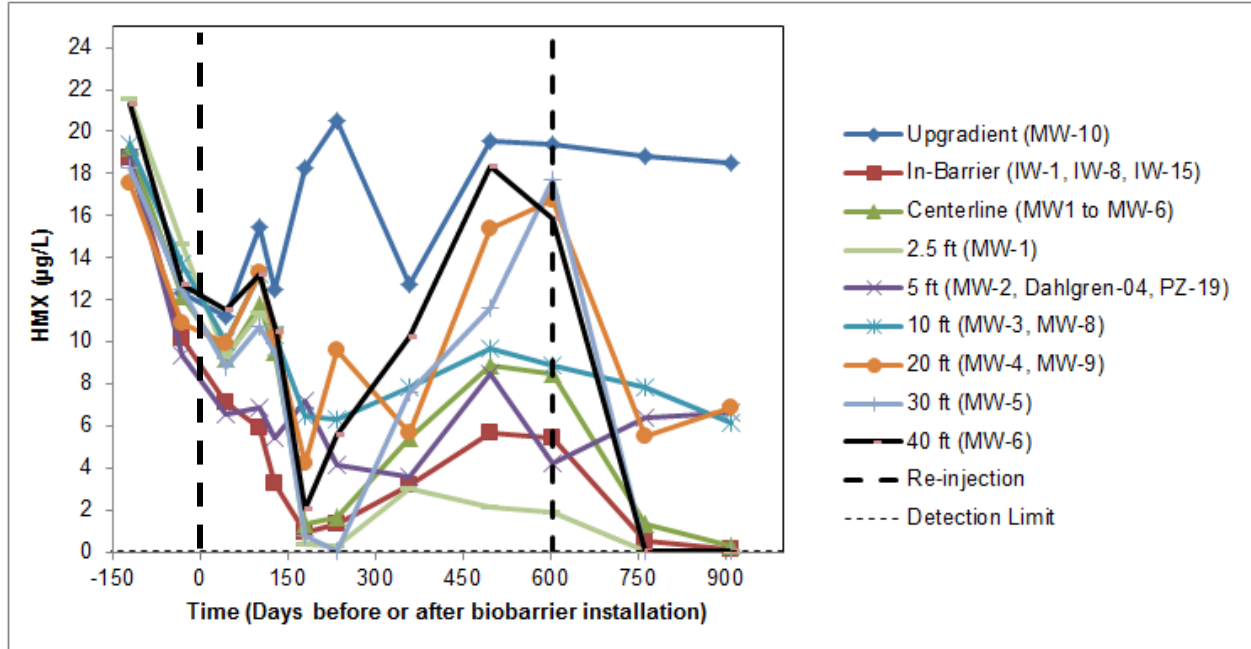

Figure 6.24. HMX concentrations groundwater over time.

All wells are represented as a function of distance from the biobarrier in panel A and the upgradient, in-barrier, and centerline downgradient wells are represented in panel B.

A



B

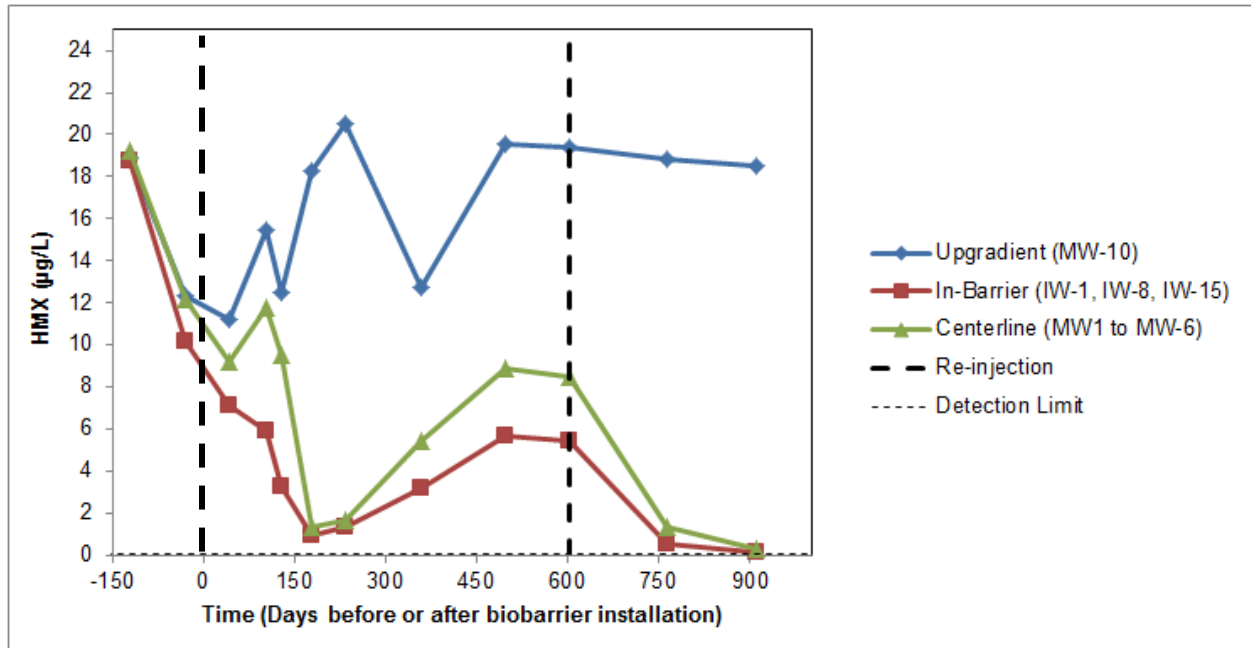
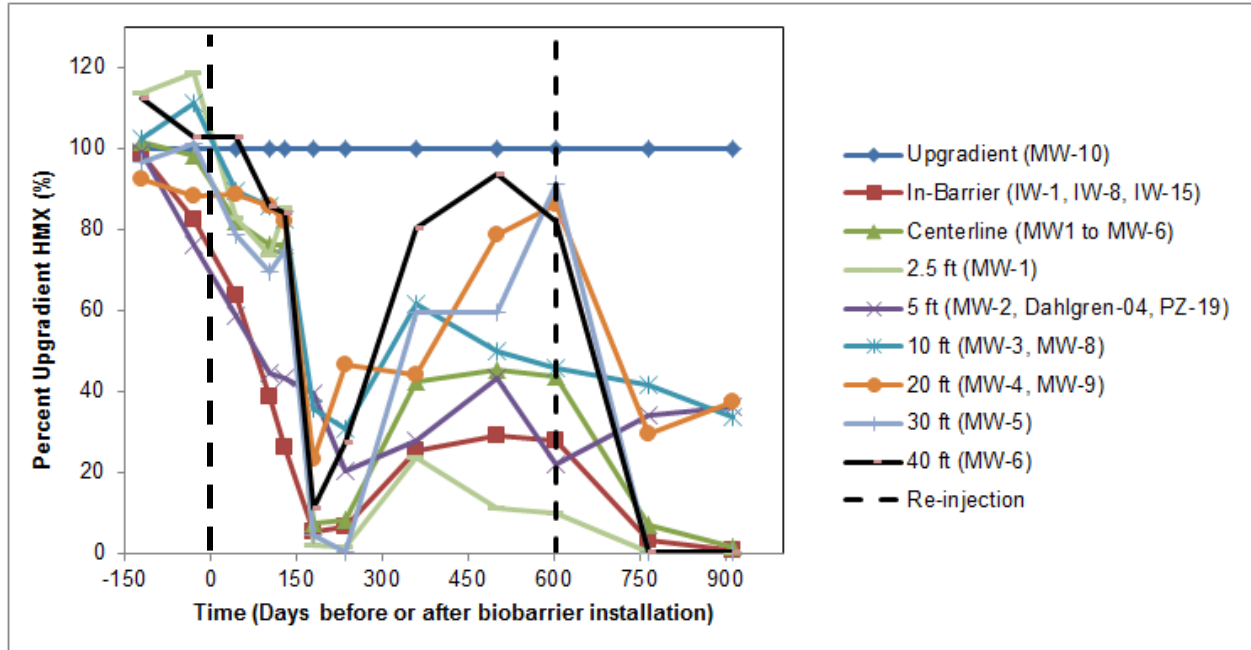

Figure 6.25. HMX concentrations at various locations in the demonstration plot relative to the upgradient concentrations over time.

All wells are represented as a function of distance from the biobarrier in panel A and the upgradient, in-barrier, and centerline downgradient wells are represented in panel B.

A



B

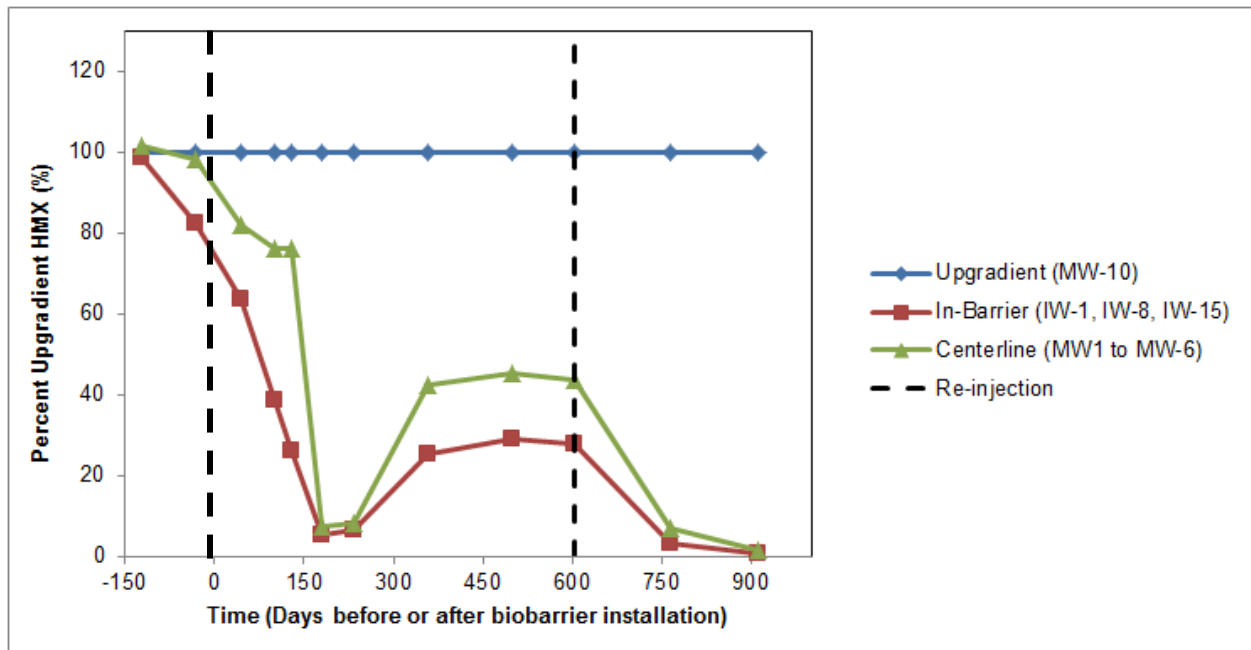
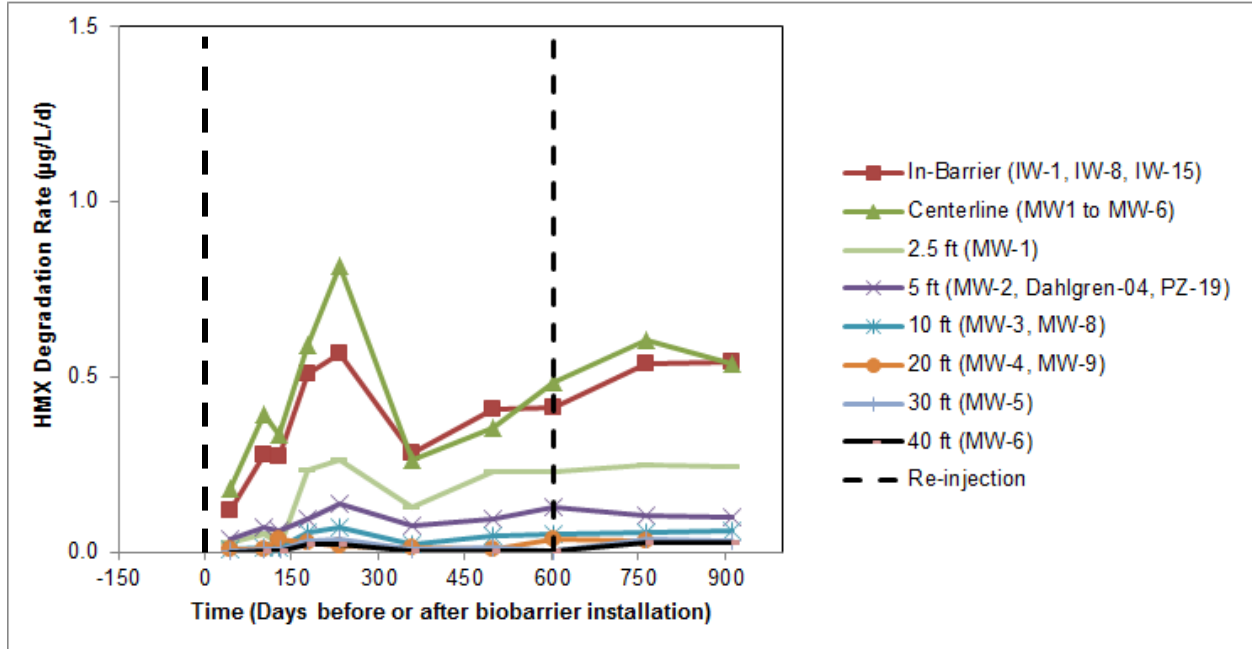

Figure 6.26. HMX degradation rates over time.

All wells are represented as a function of distance from the biobarrier in panel A and the upgradient, in-barrier, and centerline downgradient wells are represented in panel B.

A



B

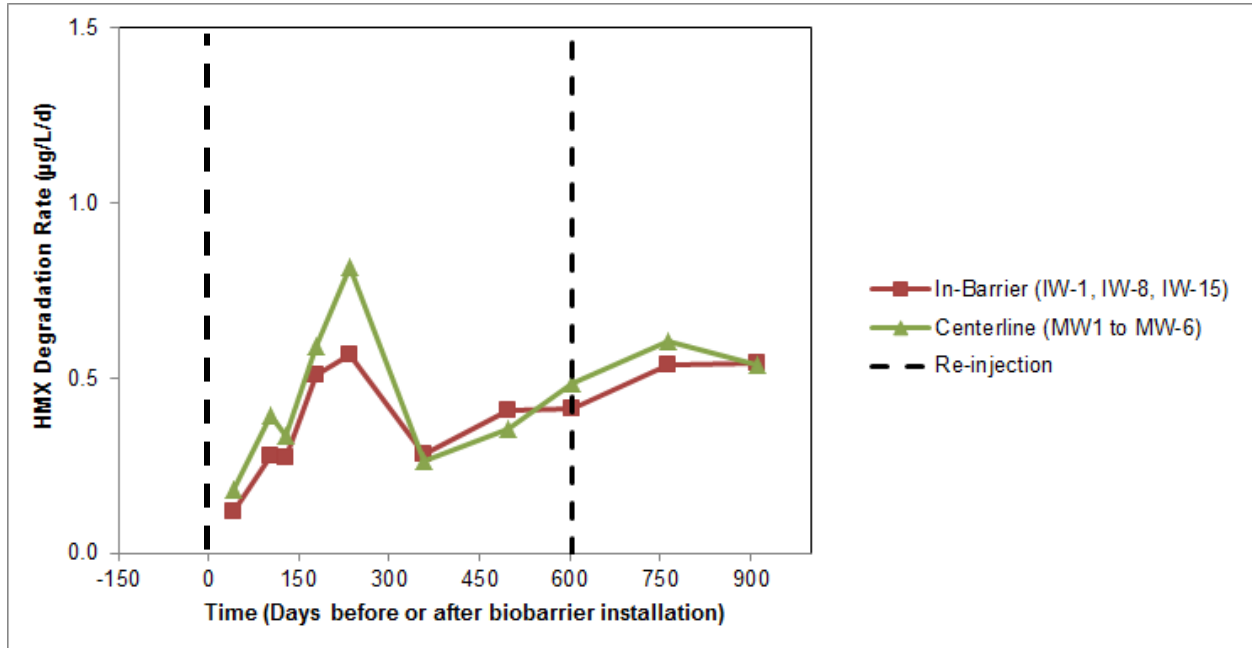

Figure 6.27. HMX degradation rate using data from upgradient well MW-10 versus all three in-barrier monitoring wells.

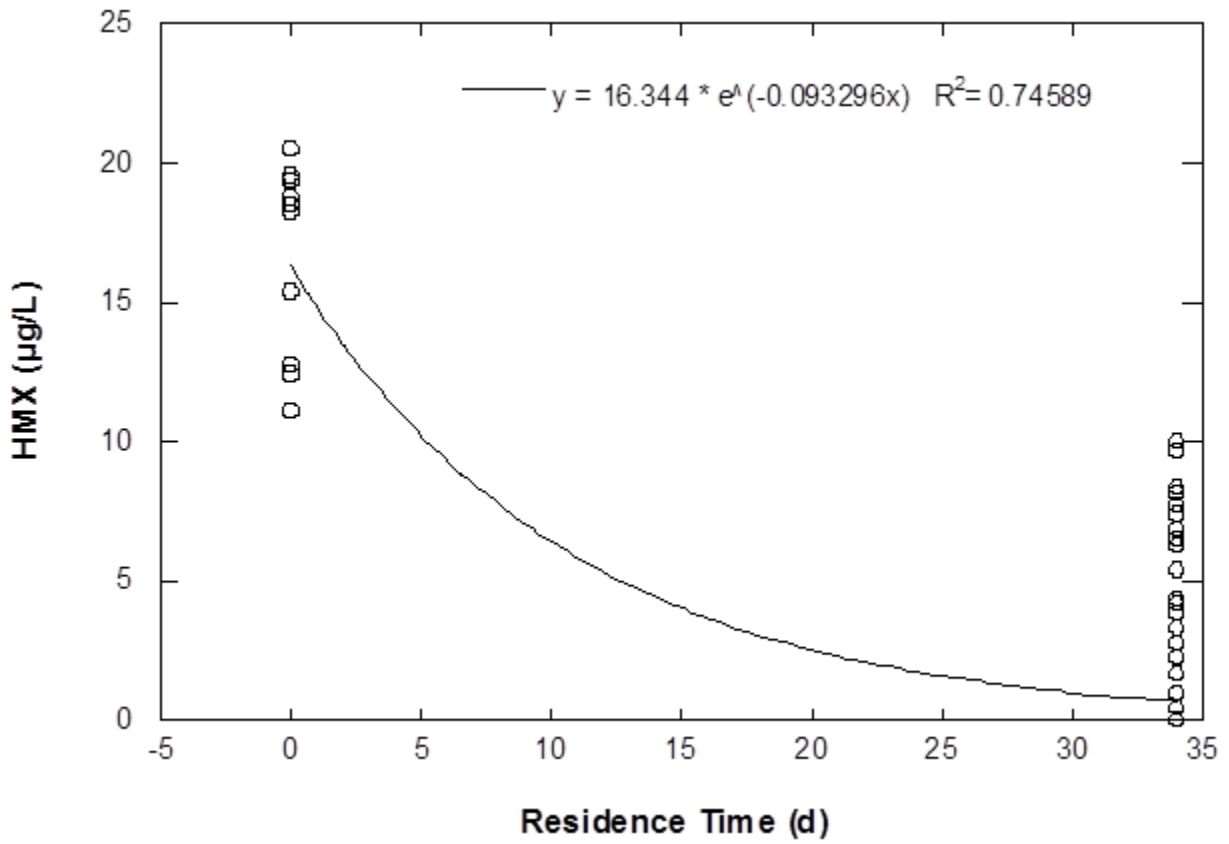
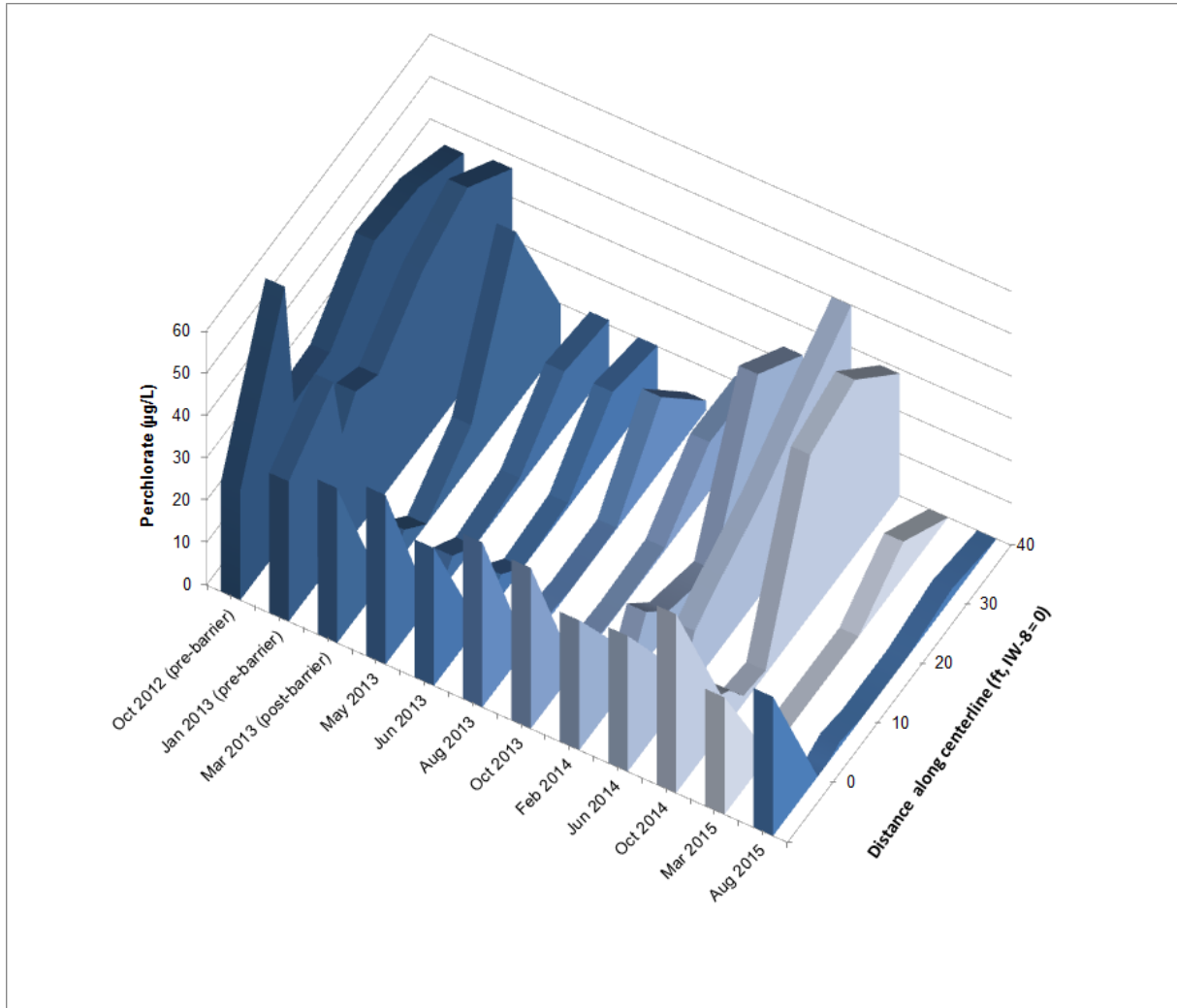

Figure 6.28. Perchlorate concentration along the centerline of the demonstration plot. Emulsified oil was re-injected after the October 2014 sampling event.

A



B

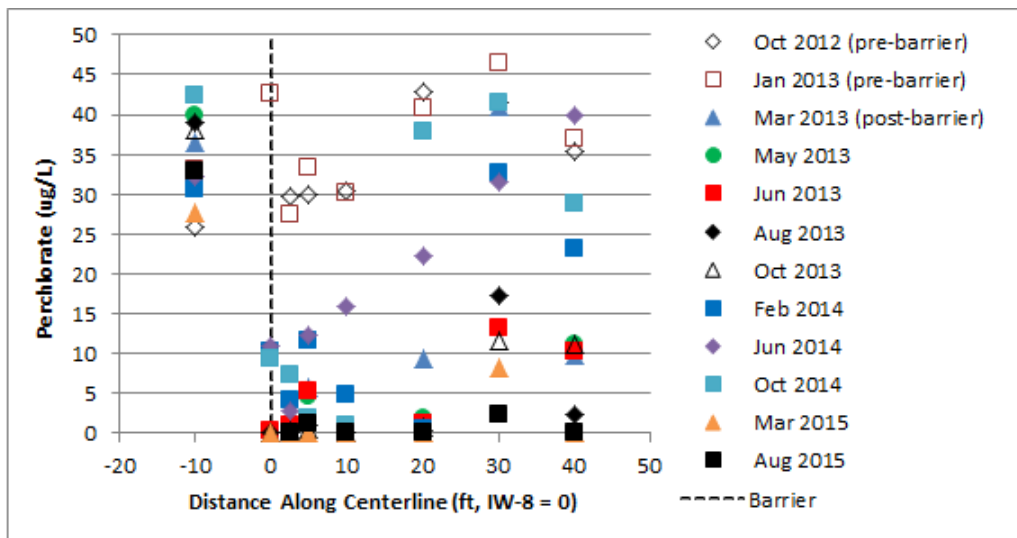
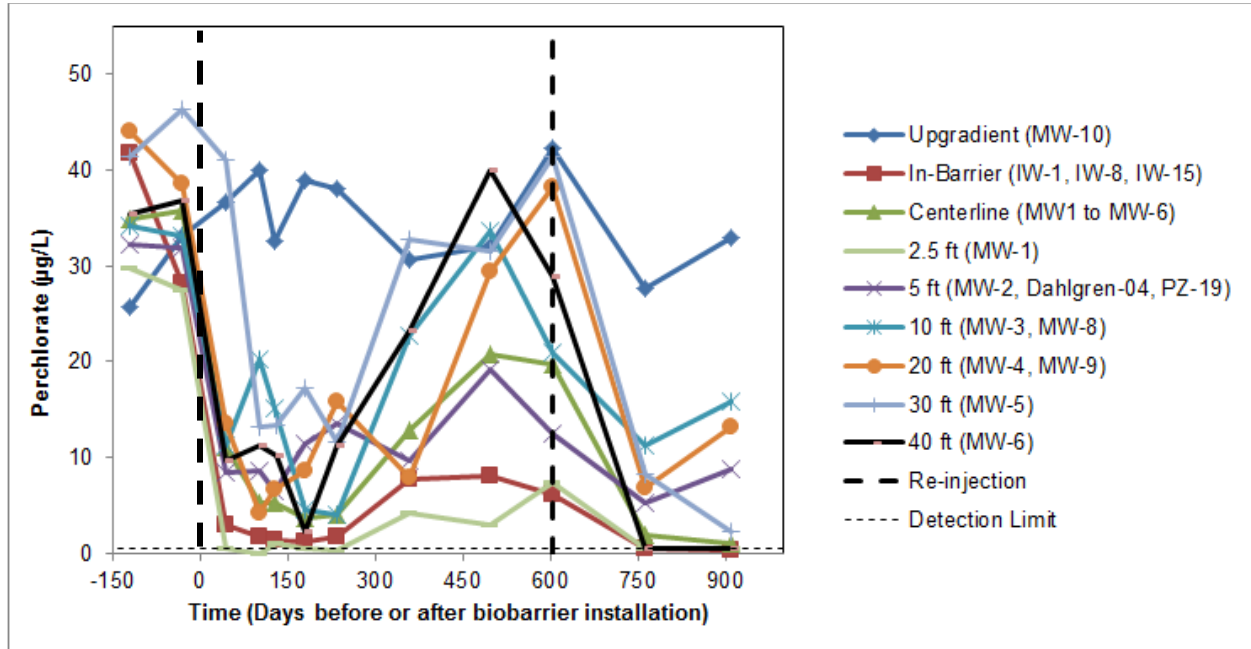

Figure 6.29. Perchlorate concentrations in groundwater over time.

All wells are represented as a function of distance from the biobarrier in panel A and the upgradient, in-barrier, and centerline downgradient wells are represented in panel B.

A



B

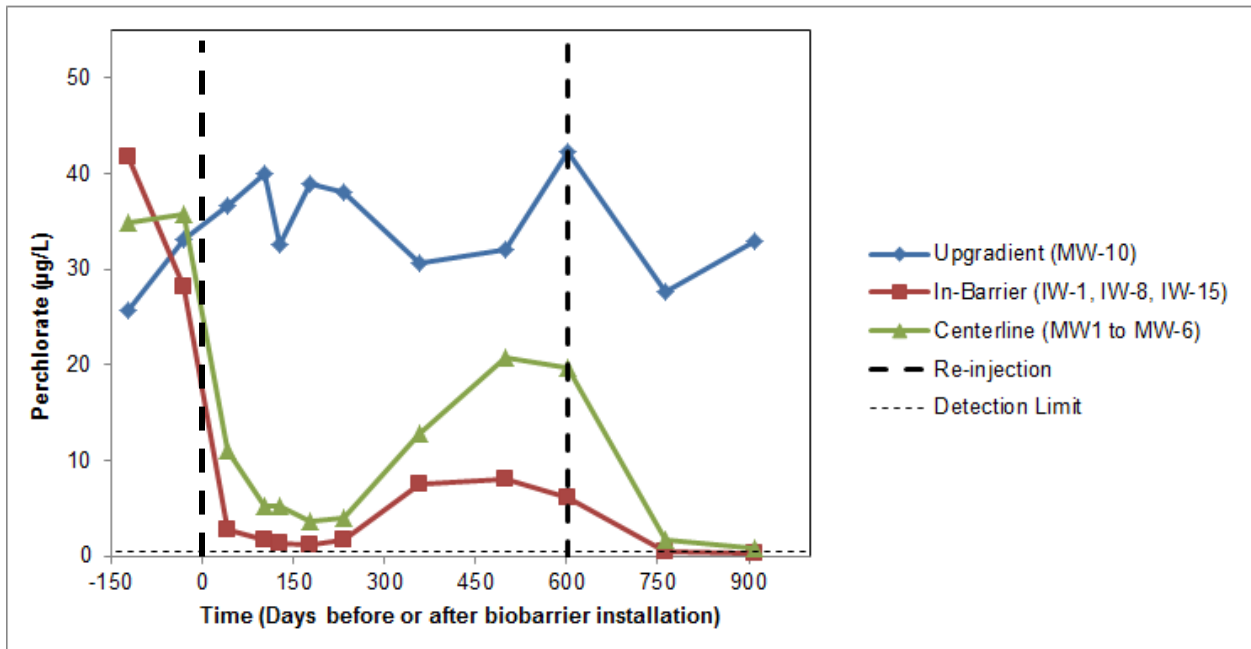
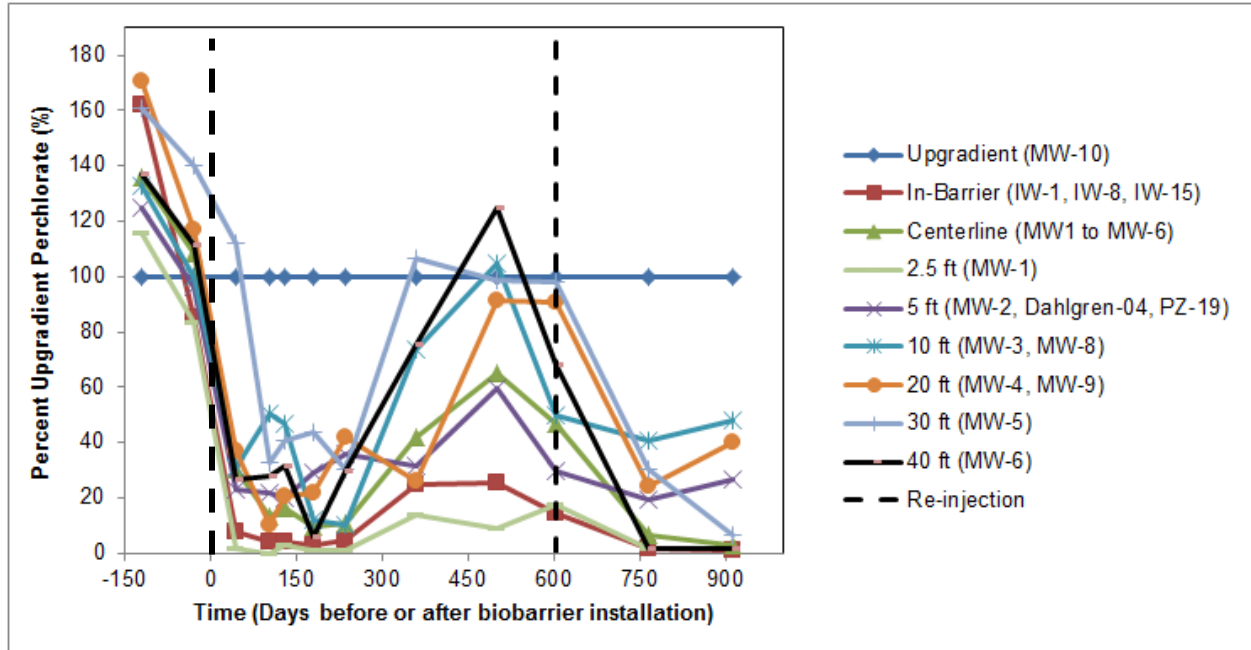

Figure 6.30. Perchlorate concentrations at various locations in the demonstration plot relative to the upgradient concentrations over time.

All wells are represented as a function of distance from the biobarrier in panel A and the upgradient, in-barrier, and centerline downgradient wells are represented in panel B.

A



B

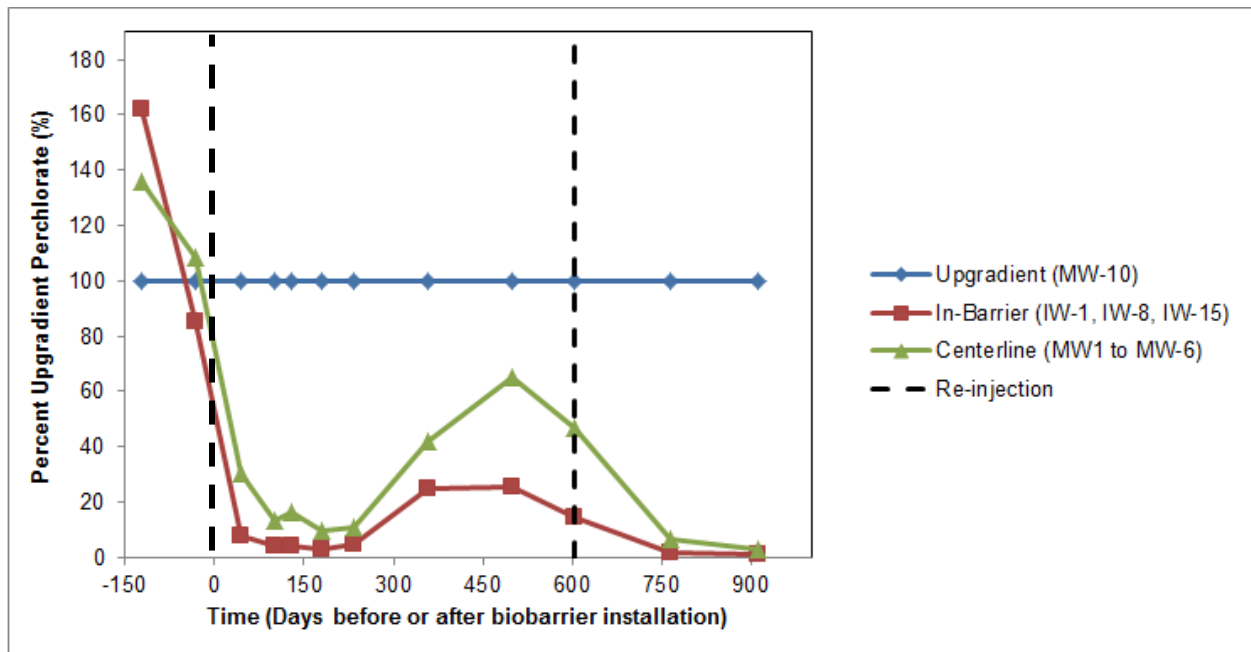

Figure 6.31. Perchlorate degradation rates over time.

All wells are represented as a function of distance from the biobarrier in panel A and the upgradient, in-barrier, and centerline downgradient wells are represented in panel B.

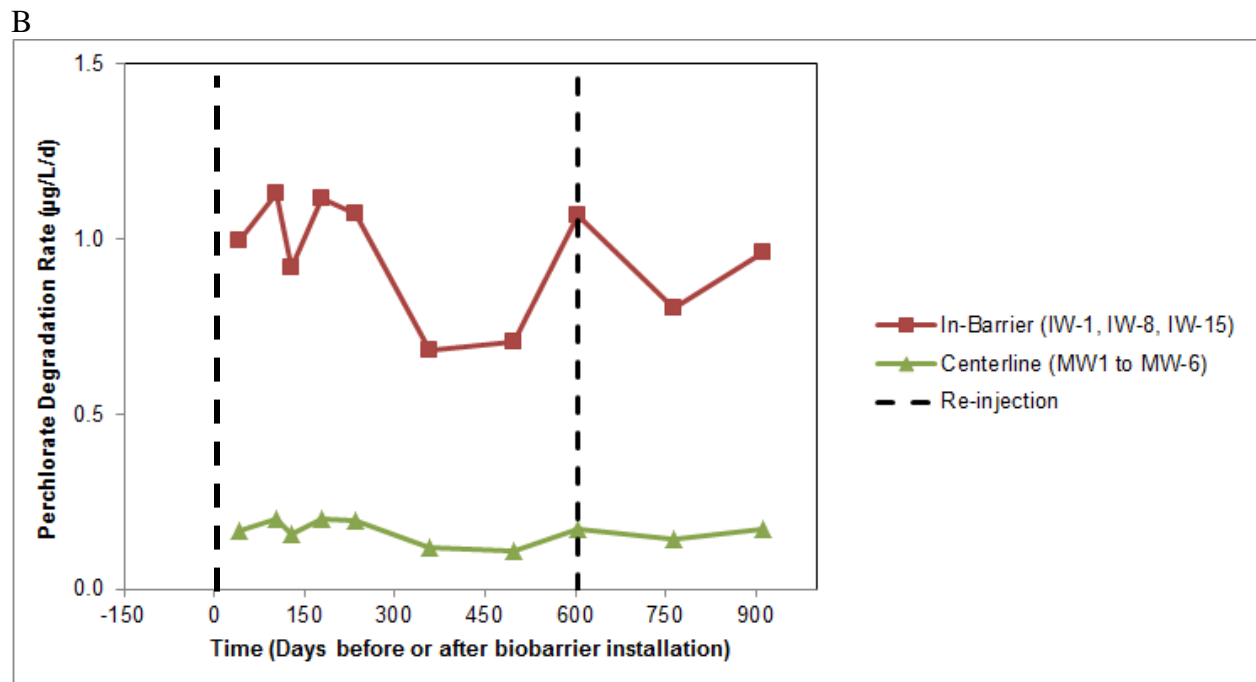
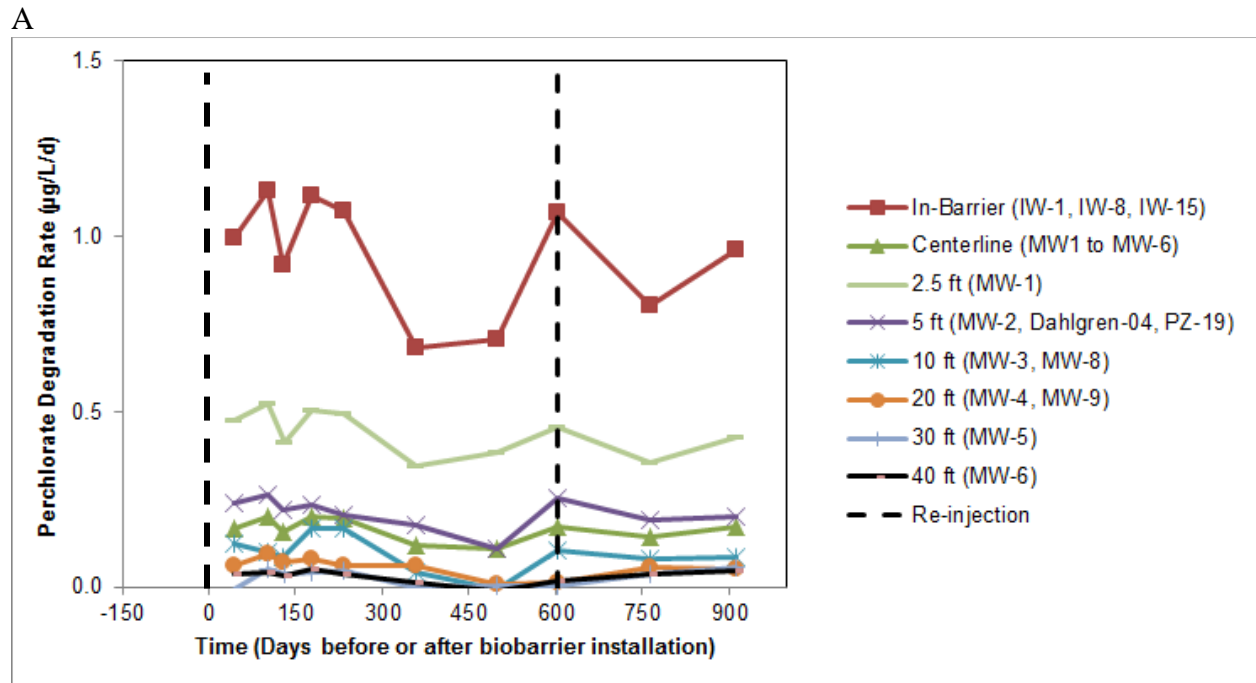
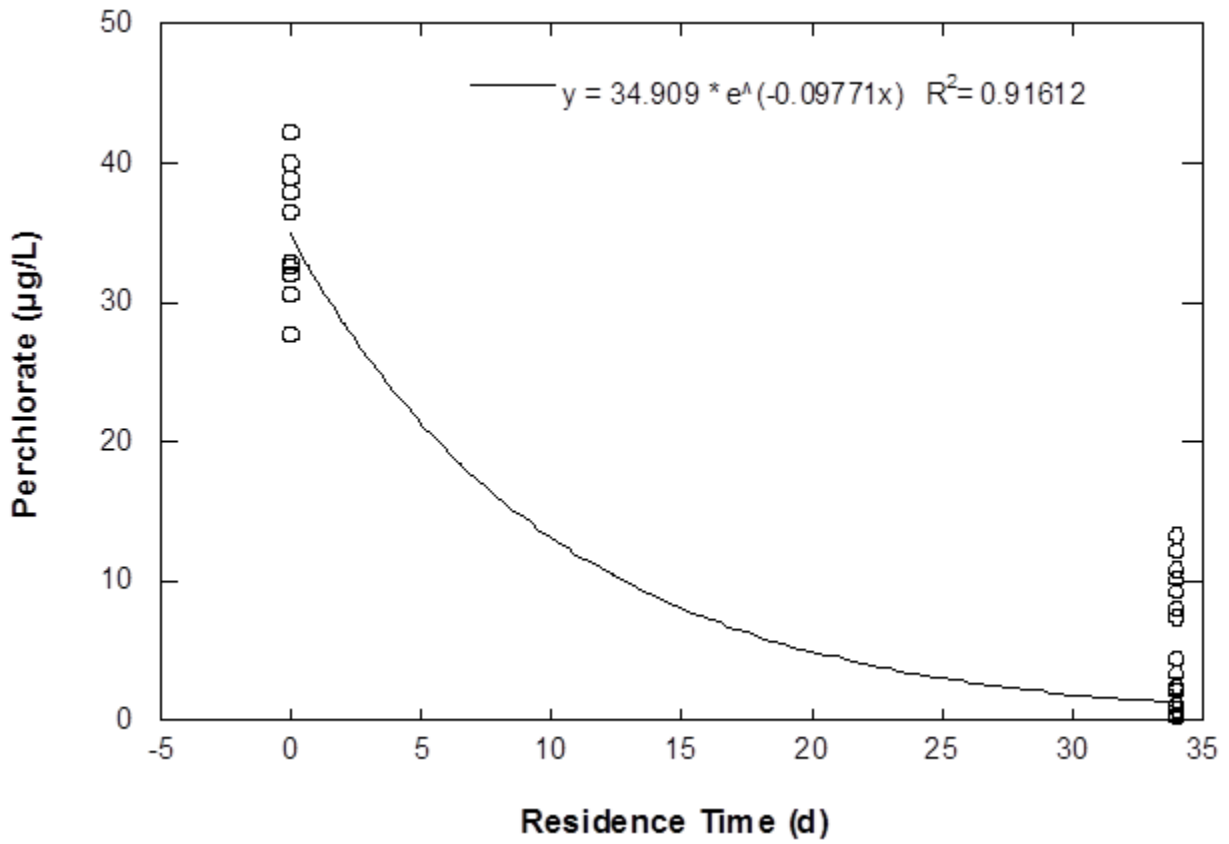

Figure 6.32. Perchlorate degradation rate using data from upgradient well MW-10 versus all three in-barrier monitoring wells.



6.3 GROUNDWATER QUALITY ANALYTES

6.3.1 Dissolved Metals

Dissolved iron, manganese, and arsenic in the site groundwater prior to the demonstration averaged $188 \pm 420 \mu\text{g/L}$ ($n = 32$), $22 \pm 26 \mu\text{g/L}$ ($n=32$), and $3 \pm 1 \mu\text{g/L}$ ($n = 32$), respectively. Upgradient concentrations in well MW-10 remained relatively stable during the demonstration, averaging $3 \pm 1 \mu\text{g/L}$ ($n = 12$) for As, $38 \pm 48 \mu\text{g/L}$ ($n = 12$) for Fe, and $7 \pm 3 \mu\text{g/L}$ ($n = 12$) for Mn.

Dissolved metals increased in response to the reducing conditions resulting from the emulsified oil injections, and were moderately variable from well to well and at each timepoint. Dissolved Fe, Mn, and As over time are presented in **Figure 6.33**, **Figure 6.34**, and **Figure 6.35**, respectively. Dissolved iron increased approximately 100-fold, averaging $16348 \pm 16064 \mu\text{g/L}$ ($n = 29$) in the in-barrier wells, and $21453 \pm 25714 \mu\text{g/L}$ ($n = 58$) in the centerline wells. Dissolved Mn concentrations did not increase as much as Fe, with in-barrier wells rising to $41 \pm 53 \mu\text{g/L}$ ($n = 29$), centerline wells rising to $35 \pm 50 \mu\text{g/L}$ ($n = 58$).

Dissolved As increased in the in-barrier wells to $17 \pm 9 \mu\text{g/L}$ ($n = 29$), and in the centerline wells to $20 \pm 22 \mu\text{g/L}$ ($n = 58$). This represents an approximately 5- to 6-fold increase over pre-demonstration concentrations. These concentrations would be expected to return to background levels downstream of the demonstration plot as the groundwater re-aerates, causing the dissolved As to oxidize and precipitate, likely forming highly insoluble mineral phases with Fe.

The most significant increase in each of the dissolved metals occurred after the second injection of emulsified oil, when a more concentrated solution was applied. This is consistent with the stimulation of higher rates of Fe and Mn reduction in the local aquifer. As in most applications where high levels of TOC are added to an aquifer, some mobilization of metals is to be expected. However, attenuation of all of these metals is anticipated downgradient as groundwater re-oxygenates.

Figure 6.33. Dissolved iron concentrations over time.

All wells are represented as a function of distance from the biobarrier in panel A and the upgradient, in-barrier, and centerline downgradient wells are represented in panel B.

A

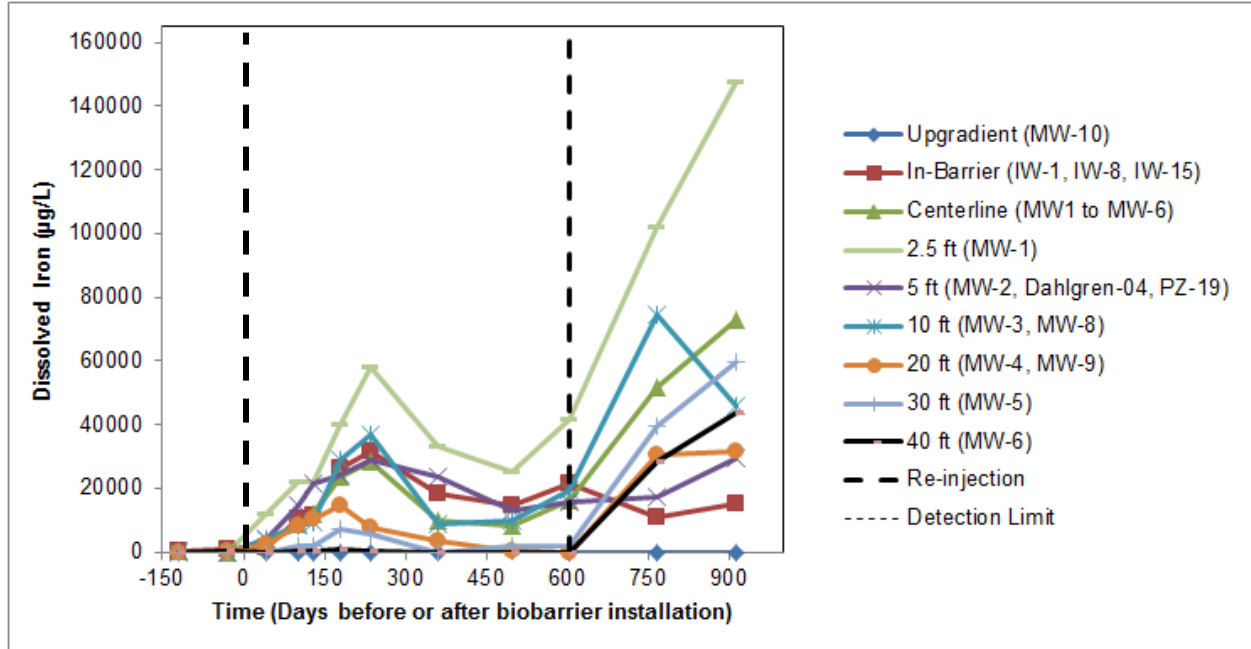

B

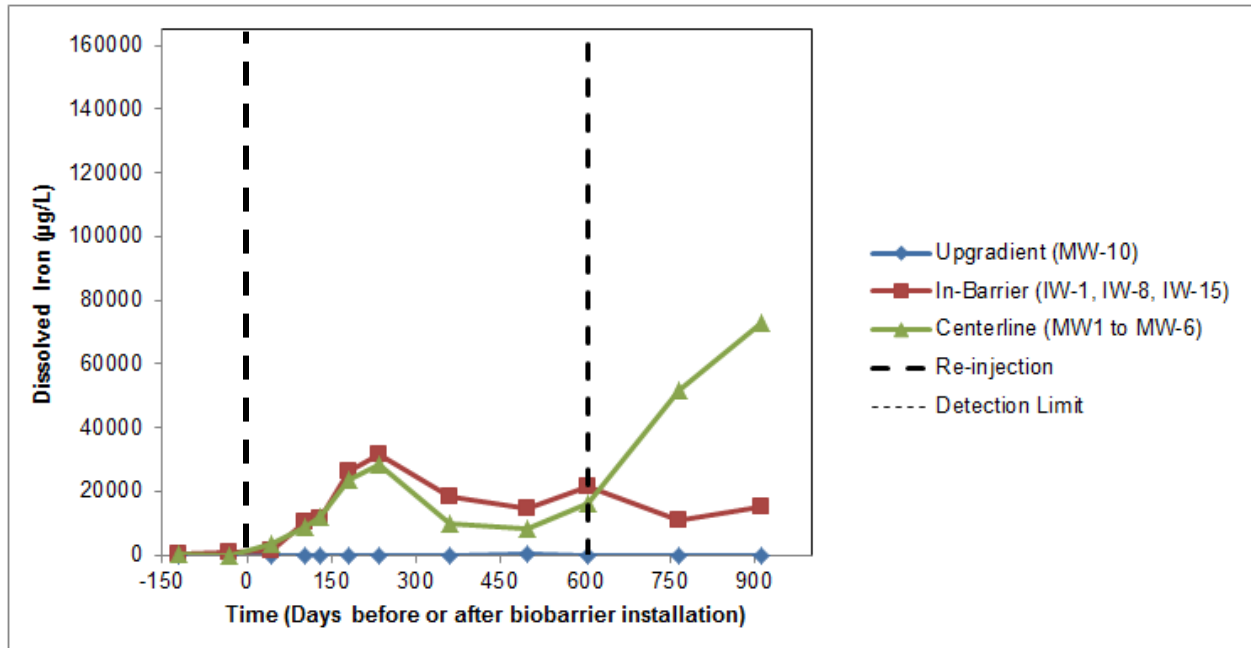
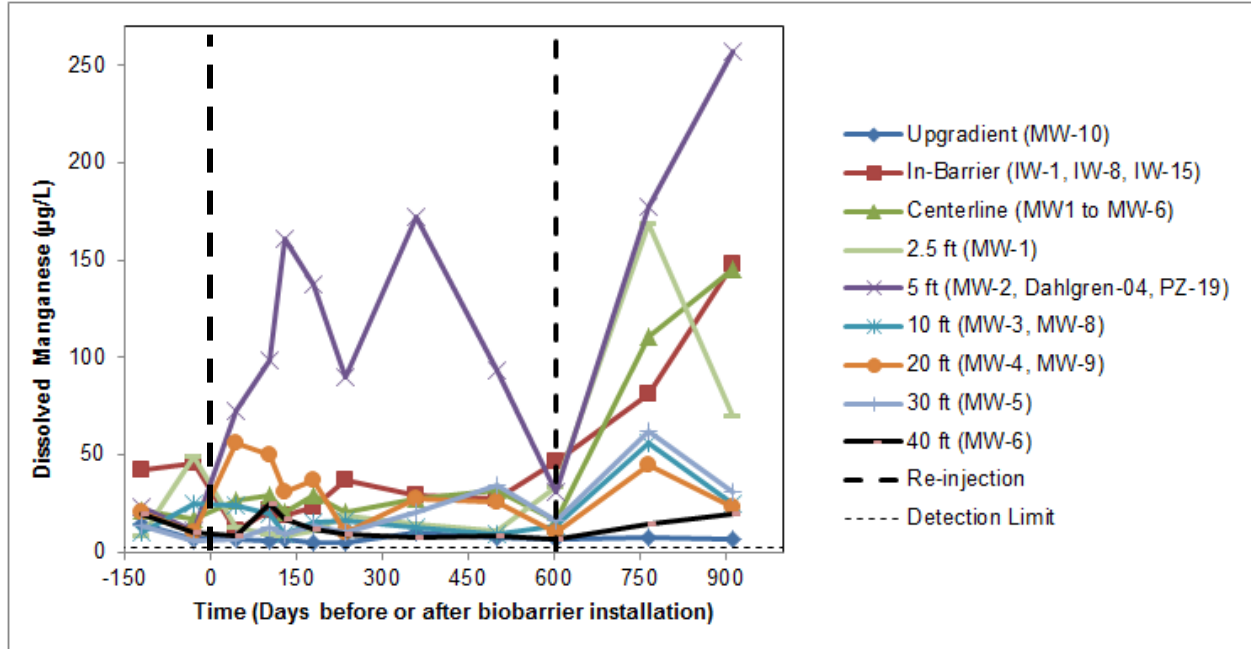

Figure 6.34. Dissolved manganese concentrations over time.

All wells are represented as a function of distance from the biobarrier in panel A and the upgradient, in-barrier, and centerline downgradient wells are represented in panel B.

A



B

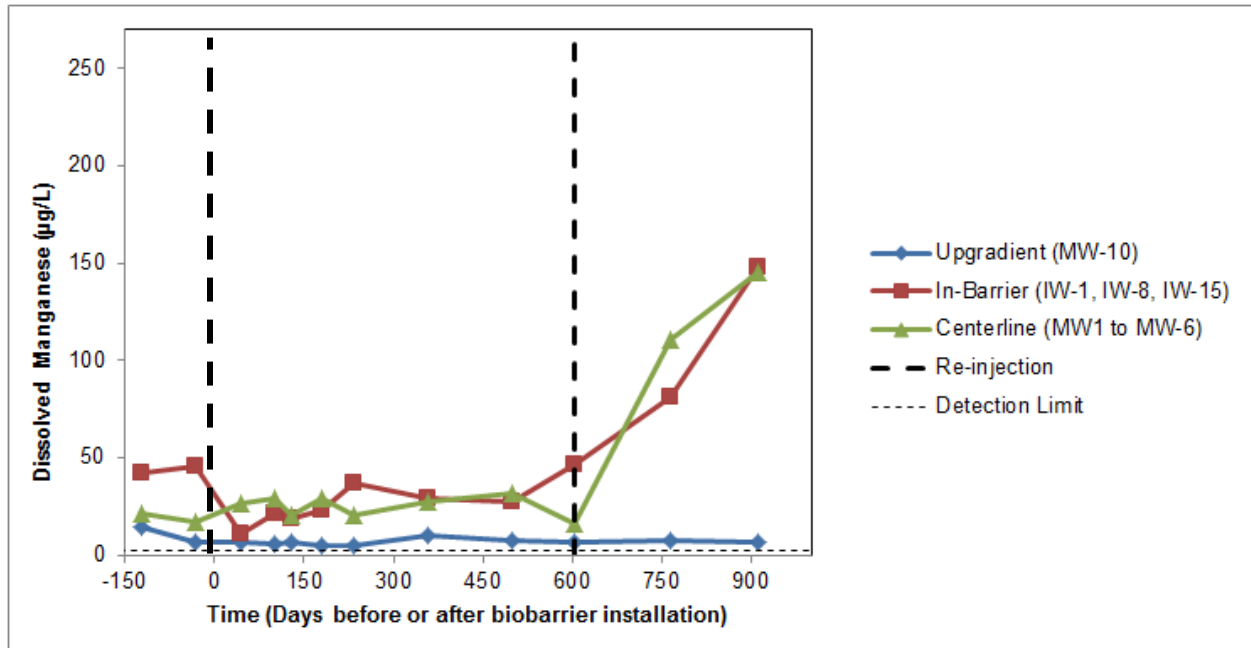
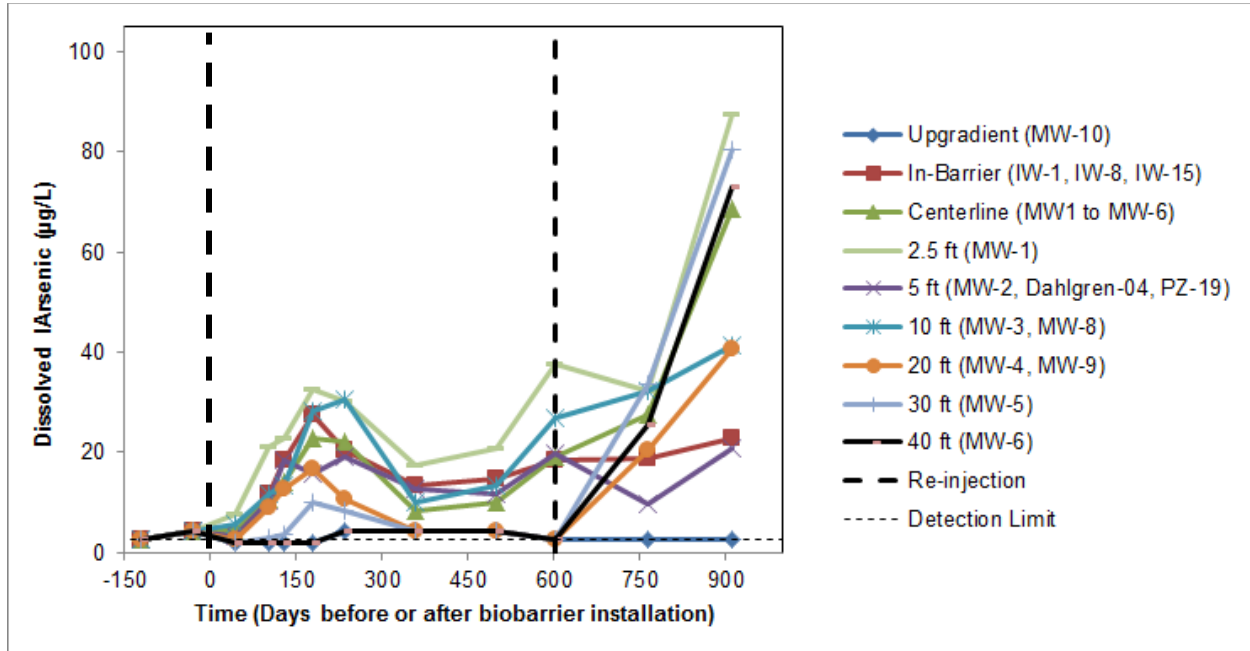

Figure 6.35. Dissolved arsenic concentrations over time.

All wells are represented as a function of distance from the biobarrier in panel A and the upgradient, in-barrier, and centerline downgradient wells are represented in panel B.

A



B

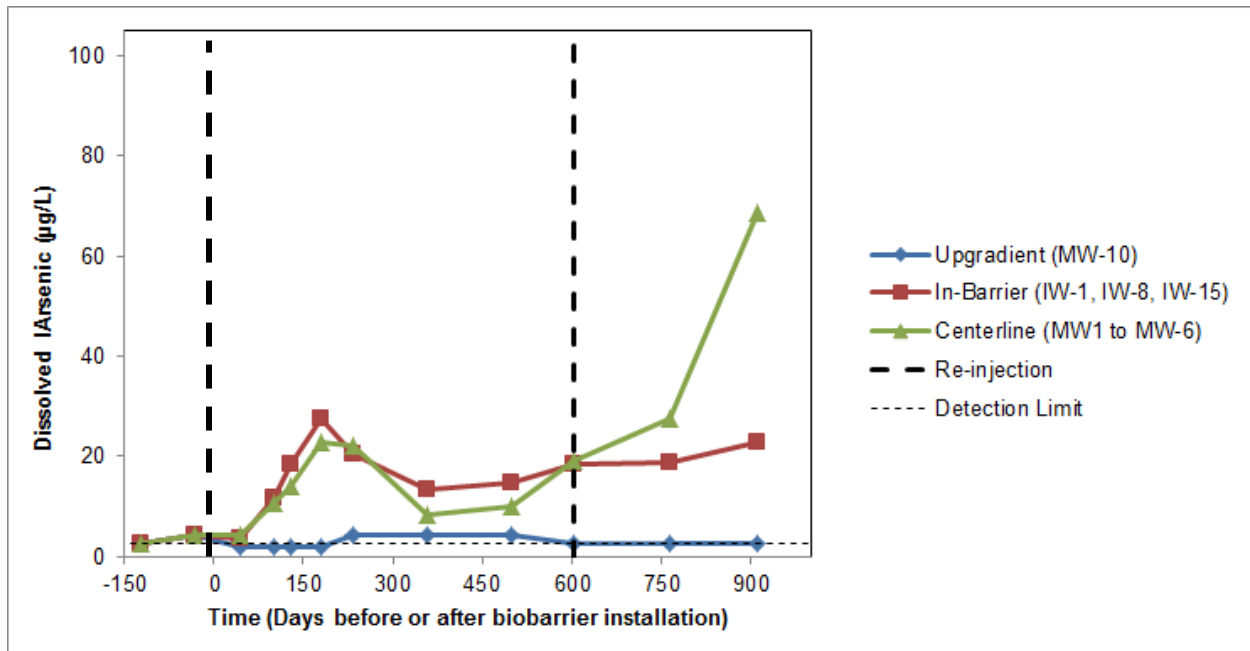

6.4 QUALITY CONTROL RESULTS

Duplicate samples were collected from a single well during each sampling event. Analytical results for perchlorate, HMX, RDX, RDX metabolites, As, and Fe were examined to determine the difference between the sample and its duplicate. Results are presented in **Table 6.2**.

The sample and duplicate collected from well MW-1 in June 2014 showed the greatest analytical variability, and did not seem to fall within the trends of the rest of data. Excluding this sample set, the percent relative standard deviation (RSD) for the main target compounds (perchlorate, HMX, and RDX) were all below 20%, as was the RSD for As. The RSD for the RDX metabolites and Fe were also less than 20% on average, but had higher variability.

Based on these data, it was concluded that the quality control objectives of the project were met.

Table 6.2. Comparison of sample and duplicate analytical results for key analytes during the demonstration.

WELL ID	DATE	DAYS	CLO4 µg/L	MNX µg/L	DNX µg/L	TNX µg/L	HMX µg/L	RDX µg/L	As µg/L	Fe µg/L
MW-4	03/25/13	43.00	9.4	3.8	0.5	0.1	10.2	51.1	3.33	1120
MW-4 DUP	03/25/13	43.00	9.5	5.0	<0.08	0.2	11.3	55.5	3.31	1070
RSD (%)			-1.1	-25.9		-18.8	-9.8	-8.3	0.6	4.6
CMOBOD02	05/23/13	102.00	34.6	<0.08	<0.08	<0.08	28.1	146.0	<2.1	<10.2
CMOBOD02 DUP	05/23/13	102.00	37.8	<0.08	<0.08	<0.08	33.0	165.3	<2.1	<10.2
RSD (%)			-8.8				-16.0	-12.4		
MW-6	06/20/13	130.00	10.2	5.3	2.0	0.6	10.5	36.6	<2.1	192
MW-6 DUP	06/20/13	130.00	12.5	5.5	2.0	0.7	11.7	38.9	<2.1	158
RSD (%)			-20.3	-3.4	2.9	-20.1	-10.3	-6.1		19.4
MW-6	08/08/13	179.00	2.3	0.95	0.46	21.38	2	6	<2.1	685
MW-6 DUP	08/08/13	179.00	2.9	1.04	0.52	18.01	1.6	5	<2.1	495
RSD (%)			-23.1	-9.5	-11.7	17.1	25.3	9.7		32.2
MW-10	10/02/13	234.00	38.0	0.33	<0.08	<0.08	21	157	<4.2	<20.4
MW-10 DUP	10/02/13	234.00	40.9	0.14	0.14	<0.08	20.6	155	<4.2	<20.4
RSD (%)			-7.4	78.3			-0.2	1.2		
PZ-30	02/04/14	359.00	43.9	0.23	<0.08	0.12	16	81	<4.2	33.2
PZ-30 DUP	02/04/14	359.00	45.3	0.23	<0.08	0.10	16	81	<4.2	<20.4
RSD (%)			-3.1	-1.2		14.8	-0.6	1.1		
MW-1	06/23/14	498.00	2.9	1.35	1.08	6.63	2	9	20.9	25100
MW-1 DUP	06/23/14	498.00	6.1	2.33	1.47	7.34	4	18	19.6	23900
RSD (%)			-71.1	-53.4	-30.5	-10.1	-52.9	-60.8	6.4	4.9
MW-10	10/06/14	603.00	42.3	<0.08	<0.08	<0.08	19	108	<2.5	<12.5
MW-10 DUP	10/06/14	603.00	41.5	<0.08	<0.08	<0.08	17	95	<2.5	<12.5
RSD (%)			1.9				14.3	13.7		
MW-4	03/16/15	764.00	<0.5	<0.08	<0.08	<0.08	<0.03	<0.03	38.6	60900
MW-4 DUP	03/16/15	764.00	<0.5	<0.08	<0.08	<0.08	<0.03	<0.03	38.8	60600
RSD (%)									-0.5	0.5
MW-4	08/11/15	912.00	<0.5	<0.08	<0.08	<0.08	<0.03	<0.03	79.2	63500
MW-4 DUP	08/11/15	912.00	<0.5	<0.08	<0.08	<0.08	<0.03	<0.03	70.8	1E+05
RSD (%)									11.2	-50.8
RSD (%)		AVG	-16.6	-2.5	-13.1	-3.4	-6.3	-7.7	3.5	15.3
		SD	23.7	44.1	16.7	18.1	23.3	23.2	4.1	13.2
RSD (%)		AVG	-8.8	7.7	-4.4	-1.8	0.4	-0.2	3.8	1.2
		SD	9.5	40.6	10.3	20.5	14.7	9.5	6.5	31.6

6.5 MICROBIOLOGICAL RESULTS

A laboratory experiment was conducted utilizing stable isotope probing (SIP) to examine the microbial community during RDX degradation in Dahlgren site groundwater and sediment slurries under different electron accepting conditions. The results summarized here are drawn from the peer-reviewed publication:

Cho, K.-C., D. G. Lee, M. E. Fuller, P. B. Hatzinger, and K.-H. Chu. 2015. Application of ^{13}C and ^{15}N stable isotope probing to characterize RDX degrading microbial communities under different electron-accepting conditions. *Journal of Hazardous Materials* 297:42-51.

The rates and dominant pathways of RDX degradation varied among the electron accepting conditions, with the most rapid and complete degradation of RDX occurring under sulfate-reducing and methanogenic conditions, and no degradation apparent under denitrifying conditions (**Figure 6-36**). No SIP was performed for nitrate reducing enrichments because RDX degradation was not observed in this case.

By using the ^{13}C -DNA fractions from the microcosms which received $^{13}\text{C}_3$ -labeled RDX as templates for cloning and sequencing, identities of active bacteria capable of using RDX and/or RDX intermediates as a carbon source were determined. As shown in **Figure 6-37**, a total of fifteen 16S rRNA sequences were derived. These sequences resided in four major clusters: *Actinobacteria* (*Eggerthella*), α -*Proteobacteria* (unclassified *Rhizobiales*), γ -*Proteobacteria* (*Pseudomonas*), and *Clostridia* (*Desulfosporosinus*). Similarly, a total of twenty seven sequences were derived from ^{15}N -DNA fractions from the microcosms receiving ring- or nitro- $^{15}\text{N}_3$ -RDX or fully-labeled $^{15}\text{N}_6$ -RDX (**Figure 6-38**). Interestingly, the clone library assembly from ^{15}N -DNA fractions was similar to that from the ^{13}C -DNA fractions. These sequences formed the three major groups in α -*Proteobacteria* (unclassified *Rhizobiales*), γ -*Proteobacteria* (*Pseudomonas*), and *Clostridia* (*Desulfosporosinus*).

Each of the major taxa of bacteria detected by ^{13}C - and ^{15}N -SIP (α -*Proteobacteria*, *Actinobacteria*, γ -*Proteobacteria* and *Clostridia*) have been previously reported to biodegrade RDX directly, or to contribute to RDX degradation in a microbial community (Andeer *et al.*, 2013; Arnett *et al.*, 2009; Bhushan *et al.*, 2004; Cho *et al.*, 2013; Cho *et al.*, 2008; Cupples, 2013; Eaton *et al.*, 2013; Jung *et al.*, 2011; Kwon *et al.*, 2014; Lee *et al.*, 2014; Lee and Brodman, 2004; Roh *et al.*, 2009) Nitrogen-fixing bacteria of the order *Rhizobiales* (in the class α -*Proteobacteria*) were detected under manganese-reducing conditions with both ^{15}N -SIP and ^{13}C -SIP, suggesting that these organisms can use RDX, or, more likely based on RDX degradation kinetics, a degradation product of RDX as a C and N source. We previously detected nitrogen-fixing *Rhizobiales* using ^{13}C -SIP (with $^{13}\text{C}_3$ -RDX) and *Azospirillum* (also a nitrogen-fixing genus) using ^{15}N -SIP in samples collected from a RDX-contaminated aquifer at Picatinny Arsenal, NJ (Cho *et al.*, 2013; Roh *et al.*, 2009). A *Rhizobium* sp. (order *Rhizobiales*) capable of biodegrading RDX was also previously isolated from a RDX-contaminated surface soil from the Picatinny Arsenal (Lee and Brodman, 2004). Moreover, nitrogen-fixing *Rhizobium* sp. and *Mesorhizobium* sp. with labeled ^{15}N -DNA were recently detected in surface soils from a Florida military training range incubated ^{15}N -RDX

(Adeer *et al.*, 2013). Thus, an increasing body of data suggests that nitrogen-fixing strains may be important members of the microbial communities involved in the biodegradation of RDX and/or RDX degradation products in the environment. However, the actual role that these organisms play (e.g., directly degrading RDX for C or N, degrading RDX metabolites, etc.), and the reason that they were detected primarily under manganese-reducing conditions (with one under sulfate-reducing conditions) in our study, remain unclear.

Actinobacteria are among the most widely studied RDX-degrading organisms, as several organisms in this phylum, including *Gordonia sp.*, *Williamsia sp.* and several *Rhodococcus spp.*, have been isolated and shown to degrade RDX in pure culture (Coleman *et al.*, 1998; Ronen *et al.*, 2008; Seth-Smith *et al.*, 2008; Thompson *et al.*, 2005). *Actinobacteria* have also been detected in communities of RDX degraders in natural environments via SIP testing (Adeer *et al.*, 2013; Cho *et al.*, 2013; Cupples, 2013; Roh *et al.*, 2009). In this study, only one sequence identified as *Actinobacteria* was detected under manganese-reducing conditions. The closest matching genus of the sequence detected, *Eggerthella*, in the family *Coriobacteriaceae*, has not previously been reported to be associated with RDX degradation. Moreover, this organism is an anaerobe, with very different physiological characteristics from the *Actinobacteria* previously reported to biodegrade RDX, most of which degrade the nitramine under aerobic or microaerophilic conditions (Fuller *et al.*, 2010).

Three sequences identified as γ -*Proteobacteria* were derived from microcosms receiving ^{13}C -labeled RDX under manganese-reducing, sulfate-reducing and methanogenic conditions, respectively. These closest matches to the three sequences (95% homology) were the known RDX degraders, *Pseudomonas fluorescens* I-C and *Pseudomonas putida* II-B (Blehert *et al.*, 1999; Park and Kim, 2000). Both *P. fluorescens* I-C and *P. putida* II-B strains transform RDX with xenobiotic reductases XenA/XenB (Fuller *et al.*, 2009) and degrade RDX via a ring-cleavage pathway. Interestingly, the *Pseudomonas sp.* were also found in the ^{15}N -fractions clone library, with three sequences in γ -*Proteobacteria* derived from microcosms receiving ring-labeled $^{15}\text{N}_3$ -RDX, and one sequence in γ -*Proteobacteria* was derived from a microcosm receiving nitro-labeled $^{15}\text{N}_3$ -RDX. The common sequences identified as *Pseudomonas sp.* from both the ^{13}C - and ^{15}N -SIP clone libraries suggest that *Pseudomonas sp.* are likely to use RDX or its metabolites as a carbon and/or a nitrogen source. These results differ from Fuller *et al.* (2009), who reported that the *Pseudomonas sp.* with xenobiotic reductases were capable of degrading RDX, but they could not utilize RDX as sole carbon or nitrogen source. It is possible that the *Pseudomonas sp.* isolated here utilized a different enzyme for RDX degradation, or that they scavenged nitrogen- or carbon-containing metabolites of RDX after the parent molecule was partially degraded by different organisms in the enrichment.

A major group of *Desulfosporosinus*, a family of sulfate-reducing bacteria, was identified from both ^{13}C -SIP and ^{15}N -SIP clone libraries. A total of nine sequences under iron-reducing, sulfate-reducing and methanogenic conditions in samples receiving $^{13}\text{C}_3$ -RDX were identified as *Desulfosporosinus*. In addition, a total of twenty two sequences were derived from microcosms under manganese-reducing, iron-reducing, sulfate-reducing and methanogenic conditions, respectively, from samples receiving ring-, or nitro- $^{15}\text{N}_3$ -RDX, and fully-labeled $^{15}\text{N}_6$ -RDX. These sequences were found to be highly similar in both ^{13}C -SIP and ^{15}N -SIP clone libraries with

the closest matches (95 to 99% homology) to the species *Desulfosporosinus lacus* (accession number: NR042202) and *Desulfosporosinus meridiei* (accession number: NR074129).

While this is the first report of a *Desulfosporosinus* sp. metabolizing RDX and/or RDX metabolites, several previous studies have revealed that sulfate-reducing bacteria, such as *Desulfovibrio* spp., are able to utilize RDX as a nitrogen source (Arnett and Adrian, 2009; Boopathy *et al.*, 1998); under anoxic conditions. Moreover, a sulfate-reducing strain with a 95% similarity to *Desulfovibrio desulfuricans*, has been observed to grow on RDX as a sole source of both carbon and nitrogen (Arnett *et al.*, 2009). The detection of *Desulfosporosinus* sp. not only under sulfate-reducing conditions, but also under iron-reducing, manganese-reducing and methanogenic conditions, is consistent with the diverse metabolism of this genus. Besides sulfate, some species can also grow using nitrate, Fe(III), or As(V) as terminal electron acceptors or by fermentative processes (Pester *et al.*, 2012). Clearly, *Desulfosporosinus* was an important organism in the degradation of RDX under a variety of electron-accepting regimens in these studies, incorporating both C and N (from ring and nitro groups) from RDX and/or RDX degradation metabolites.

Interestingly, there was little apparent overlap between the major taxa involved with RDX biodegradation in our study under Fe(III)-reducing conditions (largely *Desulfosporosinus*), and those hypothesized to be active in an RDX contaminated aquifer in Iowa under Fe(III)-reducing conditions, which were predominantly *Geobacteraceae* and *Bacteroidetes* based on results from pyrosequencing analysis and t-RFLP (Livermore *et al.*, 2013). These differences may reflect site-specific microbiology, different selective pressures based on substrates used to stimulate activity (succinate vs acetate), or methodological differences, as the pyrosequencing technique, while capable of rapidly identifying large numbers of organisms cannot specifically determine which of those organisms are actively degrading RDX. It would be interesting in future work to utilize both techniques together to compare and contrast shifts in overall microbial community dynamics (via pyrosequencing) due to bulk changes in aquifer geochemistry (e.g., due to addition of a carbon substrate to an aquifer) with dynamics of the RDX-degrading community (via SIP), which may be only a small subset of the former.

A wide variety of organisms have been identified using the ¹³C- and ¹⁵N-labeled RDX SIP approaches in this study. These data provide a better understanding of active RDX degrading microbial communities and C and N disposition in those communities under different geochemical conditions. It should be noted, however, that the isolates identified may degrade parent RDX or one of several different potential RDX intermediates (e.g., TNX) and subsequently incorporate C or N from those molecules. As noted in SIP studies with other compounds, it is not possible to conclusively discern RDX degraders from degraders of RDX metabolites (DeRito *et al.*, 2005; Radajewski *et al.*, 2003; Radajewski *et al.*, 2002). However, it is reasonable to assume that the organisms identified in the methanogenic and sulfate reducing SIP enrichments were more likely to be directly responsible for RDX degradation, given the shorter SIP incubation period (<40 days) and the relatively low percentages of persistent nitroso metabolites. In contrast, the longer SIP incubation periods (100 to 260 days), and the overall persistence of nitroso metabolites observed with the iron and manganese reducing SIP enrichments would tend to indicate that the identified sequences likely included more “scavenger” organisms that incorporated the label from RDX metabolites.

Three major groups in α -Proteobacteria (unclassified *Rhizobiales*), γ -Proteobacteria (*Pseudomonas*), and Clostridia (*Desulfosporosinus*) were present and responsible for RDX and/or RDX-intermediate degradation under various electron-accepting conditions. Some *Desulfosporosinus* species are known for their adaptable metabolism, including their ability to use not only sulfate, but also nitrate, Fe(III), or As(V) as terminal electron acceptors (Pester *et al.*, 2012). This might explain why the majority of clones detected in this study are clustered in the genus of *Desulfosporosinus* under each of the different electron-accepting conditions where RDX degradation was observed. Similarly, the frequent detection of sequences identified as *Pseudomonas* likely reflects the unique ability of this genus to use many different electron acceptors. The detection of sequences identified as *Pseudomonas* sp. from highly anaerobic enrichments (e.g., sulfate reducing and methanogenic conditions) has been reported previously (Park *et al.*, 2011; Zheng *et al.*, 2013). The detection of *Pseudomonas* sp. during this study under differing geochemical conditions, and with both C and N SIP, highlights the wide diversity of this genus, and their importance in many environmental processes.

Our data suggest that, from a remediation perspective, sulfate-reducing or methanogenic conditions are desirable for RDX treatment in order to avoid the long-term accumulation of nitroso-intermediates. The selection of carbon substrate added during biostimulation may be one means of driving the degradative processes in a favorable direction. Use of emulsified vegetable oils has been shown to generate good sulfate-reducing and methanogenic conditions, and also serves as a long-term source of short chain organic acids that may favor the growth of preferred degradative genera like *Pseudomonas*. The data also suggest, surprisingly, that some groups of bacteria, such as *Desulfosporosinus*, can play an important role in RDX degradation under a variety of different dominant electron-accepting conditions. One area for future study is better understanding of the roles of *Desulfosporosinus* and *Pseudomonas* (and closely-related species) during in situ RDX degradation.

Figure 6.36. RDX degradation and RDX metabolite formation, under different electron accepting conditions.

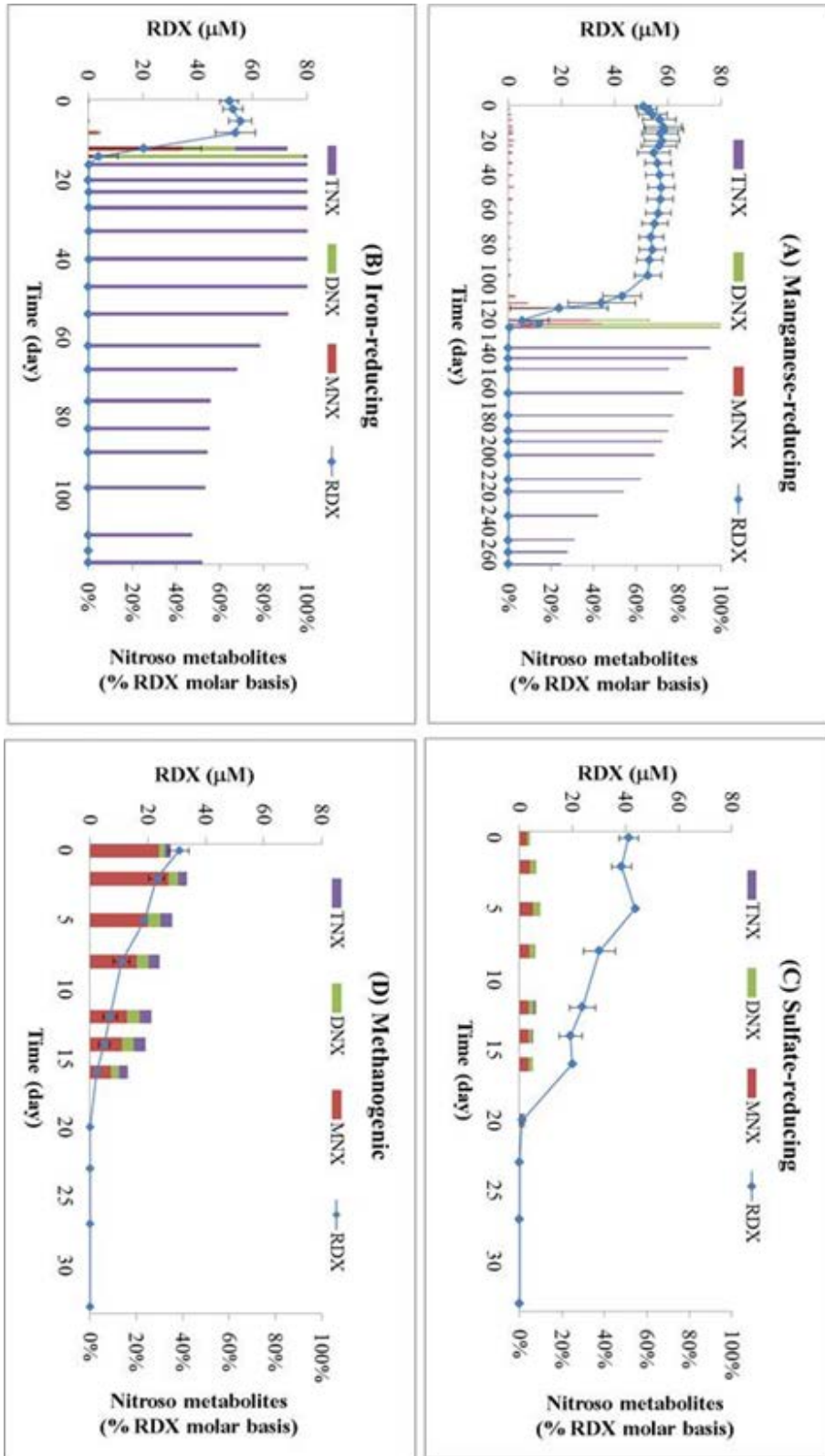
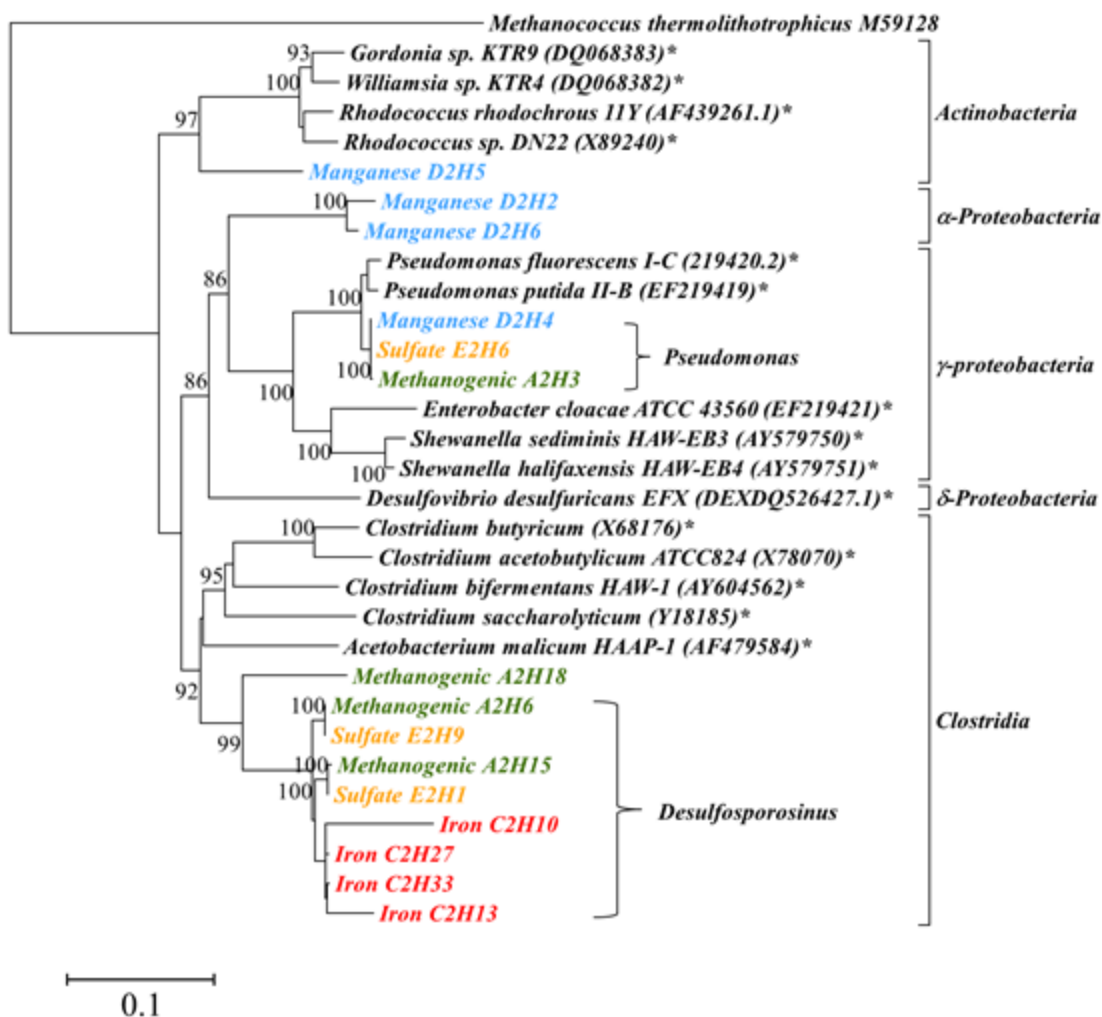
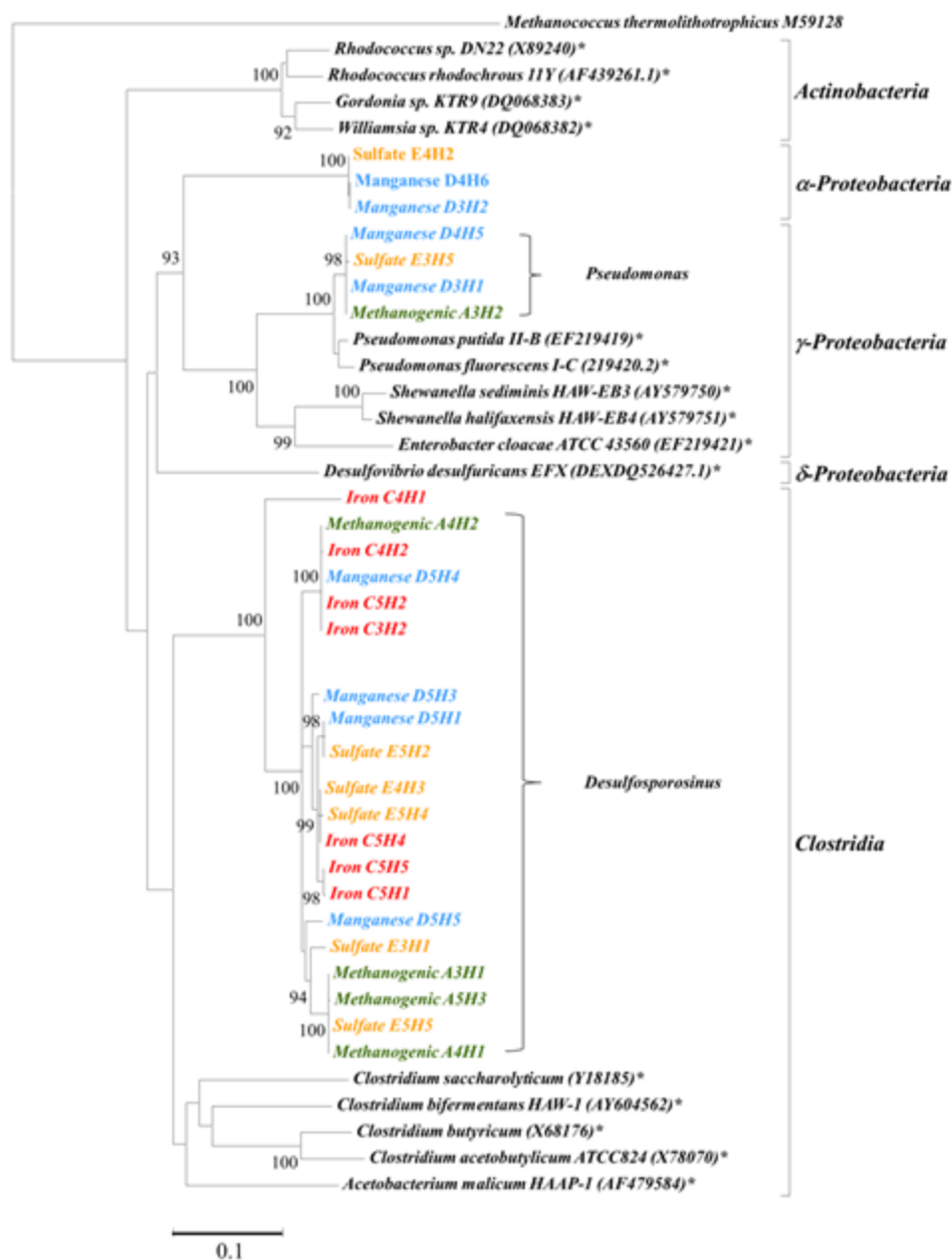

Figure 6.37. Phylogenetic tree representing 16S rRNA gene sequences derived from ¹³C-DNA fractions of microcosms receiving ¹³C3-labeled RDX under different electron acceptor conditions.



The tree was rooted with *Methanococcus thermolithotrophicus* and was constructed using the neighbor-joining algorithm. Only bootstrap values above 85% are shown (1,000 replications). Bar, 10% estimated sequence divergence. An asterisk (*) indicates a known RDX degrader.

Figure 6.38. Phylogenetic tree representing 16S rRNA gene sequences derived from ¹⁵N-DNA fractions of microcosms receiving ¹⁵N-labeled RDX (ring- or nitro-¹⁵N₃-RDX, and fully-labeled ¹⁵N₆-RDX) under different electron acceptor conditions.



The tree was rooted with *Methanococcus thermolithotrophicus* and was constructed using the neighbor-joining algorithm. Only bootstrap values above 85% are shown (1,000 replications). Bar, 10% estimated sequence divergence. An asterisk (*) indicates a known RDX degrader.

7.0. PERFORMANCE ASSESSMENT

7.1 PERFORMANCE OBJECTIVES

Performance objectives are summarized in **Table 7.1**, and detailed assessments of each performance objective are provided in **Sections 7.2** through **7.6**.

Table 7.1. Performance objective assessment.

Performance Objective	Data Requirements	Success Criteria	Results
Quantitative Performance Objectives			
Effectiveness of RDX treatment	Pre- and post-treatment contaminant concentrations in groundwater wells using EPA Method 8330.	<ul style="list-style-type: none"> Reduction in downgradient groundwater in one or more monitoring well(s) to <1.08 µg/L 	<p>SUCCESS</p> <ul style="list-style-type: none"> Wells as far as 40 ft from the barrier achieved RDX <1.08 µg/L at some point post-injection Also achieved HMX <1.08 µg/L to 40 ft downgradient at some timepoints
		<ul style="list-style-type: none"> Overall downgradient RDX reduction >95% 	<p>PARTIAL SUCCESS</p> <ul style="list-style-type: none"> In-barrier wells reached >95% reduction in RDX 50% of the demonstration period and >99% reduction for 43% of the demonstration period The averaged centerline wells (from 2.5 to 40 ft downgradient) achieved >95% reduction in RDX for 35% of the demonstration Similar removal percentages for HMX
		<ul style="list-style-type: none"> Statistical comparison: <ul style="list-style-type: none"> - Pre- and post-barrier installation - Upgradient vs. downgradient monitoring wells 	<p>SUCCESS</p> <ul style="list-style-type: none"> Over demonstration duration, upgradient RDX concentrations were statistically higher than RDX concentrations in the in-barrier wells, and in the centerline wells at the P <0.0001 Upgradient RDX was statistically higher than RDX detected 40 ft downgradient (P <0.005)

Table 7.1 (cont.)

Performance Objective	Data Requirements	Success Criteria	Results
Effectiveness of perchlorate treatment	Pre- and post-treatment contaminant concentrations in groundwater wells using EPA Method 314.0.	<ul style="list-style-type: none"> Reduction in one or more downgradient monitoring wells to <2 µg/L 	<p>SUCCESS</p> <ul style="list-style-type: none"> Wells as far as 40 ft from the barrier achieved perchlorate <2 µg/L at some point post-injection
		<ul style="list-style-type: none"> Overall downgradient perchlorate reduction >95% 	<p>PARTIAL SUCCESS</p> <ul style="list-style-type: none"> In-barrier wells reached >95% reduction in perchlorate 60% of the demonstration period centerline wells (from 2.5 to 40 ft downgradient) achieved >95% reduction in perchlorate for 48% of the demonstration
		<ul style="list-style-type: none"> Statistical comparison: <ul style="list-style-type: none"> - Pre- and post-barrier installation - Upgradient vs. downgradient monitoring wells 	<p>SUCCESS</p> <ul style="list-style-type: none"> Over demonstration duration, upgradient perchlorate concentrations were statistically higher than perchlorate concentrations in the in-barrier wells, and in the centerline wells at the P <0.0001 significance Upgradient perchlorate was statistically higher than perchlorate detected 40 ft downgradient (P <0.005)¹

¹ The statistical significance for well MW-5 (30 ft downgradient) was P = 0.0781, while that for well MW-6 (40 ft downgradient) was P = 0.0016.

Table 7.1 (cont.)

Performance Objective	Data Requirements	Success Criteria	Results
Distribution of emulsified oil	Measurement of TOC	TOC elevated in monitoring wells 2.5 ft and 5 ft downgradient	<p>SUCCESS</p> <ul style="list-style-type: none"> • TOC was greater than the background levels at 2.5 ft and 5 ft downgradient 100% and 90% of the demonstration period, respectively • Additionally, elevated TOC was detected 40 ft downgradient
Geochemical changes to create conditions necessary for contaminant degradation	Measurements of DO	DO <1 mg/L in all treatment wells	<p>SUCCESS</p> <ul style="list-style-type: none"> • DO levels <1 mg/L were measured in all treatment wells out to 40 ft downgradient more than 40% of the demonstration period • DO was <1 mg/L at 2.5 ft and 5 ft downgradient 89% and 54% of the demonstration period, respectively
	Measurements of ORP	ORP below -100 mV in all treatment wells	<p>SUCCESS</p> <ul style="list-style-type: none"> • ORP levels below -100 mV were detected in all treatment wells out to 30 ft downgradient at various timepoints during the demonstration

Longevity of biobarrier	Measurement of TOC	Elevated TOC for two (2) years after installation	<p>SUCCESS</p> <ul style="list-style-type: none"> • TOC levels above the background were observed in all wells for at least two (2) years.
	RDX concentrations in groundwater wells using EPA Method 8330.	RDX below VA Groundwater Protection Standard of 1.08 µg/L for two (2) years after installation	<p>PARTIAL SUCCESS</p> <ul style="list-style-type: none"> • One in-barrier well had RDX below the protection standard for more than two years. Three additional wells met the standard at least once during the first two years.
	Perchlorate concentrations in groundwater wells using EPA Method 314.0.	Perchlorate below VA Groundwater Protection Standard of 2 µg/L for two (2) years after installation	<p>PARTIAL SUCCESS</p> <ul style="list-style-type: none"> • Two wells had perchlorate below the protection standard for more than two years. Seven additional wells met the standard at least once during the first two years.

Qualitative Performance Objectives			
Barrier Installation	Total time for installation Feedback from field technician	<5 days for barrier installation	<p>SUCCESS</p> <ul style="list-style-type: none"> • Combined time for injection well emplacement and emulsified oil injection was less than 5 days
	Maintenance logs & time	Minimal maintenance costs	<p>SUCCESS</p> <ul style="list-style-type: none"> • No maintenance costs for injection wells once emplaced • Initial and second emulsified oil substrate costs were minimal

7.2 EFFECTIVENESS OF RDX AND PERCHLORATE TREATMENT

The effectiveness of the biobarrier technology for groundwater remediation was a function of the degree to which RDX and perchlorate concentrations decreased. Remediation success depended on the residual contamination during and after application of the treatment remedy. The overall duration of the biobarrier performance was also of interest and was quantified via extended testing.

7.2.1 Data Requirements for RDX and Perchlorate Treatment

Two rounds of baseline data were collected prior to emulsified oil injection, and ten rounds of sampling were conducted after the baseline assessment. A second emulsified oil injection was performed approximately 20 months after the initial injection. The final two sampling rounds were conducted after the second oil injection.

7.2.2 Success Assessment for RDX and Perchlorate Treatment

As summarized in **Table 7.1**, the demonstration succeeded or partially succeeded in meeting the performance assessment criteria for RDX and perchlorate remediation. HMX was also remediated to a large degree during the demonstration. Full details for RDX/HMX and perchlorate are presented in Section 6.2.1 Section 6.2.2, respectively. Summary results are presented below.

RDX Treatment.

Criteria: Reduce RDX concentrations to <1.08 µg/L in at least one downgradient well.

Assessment: Success

RDX was degraded to below the 1.08 µg/L performance criterion in multiple in-barrier and downgradient wells during the demonstration. A total of 26 samples out of the 160 samples (16%) collected from the in-barrier and downgradient wells after the initial emulsified oil injection had RDX below 1.08 µg/L. For the in-barrier wells, 13 out of 30 samples (43%) met the RDX criteria, while along the centerline (2.5 ft to 40 ft downgradient) 12 out of 60 samples (20%) met the RDX criteria.

While not a formal performance goal, HMX was degraded to below the 1.08 µg/L in multiple in-barrier and downgradient wells during the demonstration. Full details of HMX results are presented in Section 6.2.1 above. A total of 40 samples out of the 160 samples (25%) collected from the in-barrier and downgradient wells after the initial emulsified oil injection had HMX below 1.08 µg/L. For the in-barrier wells, 13 out of 30 samples (43%) had HMX below 1.08 µg/L, while along the centerline (2.5 ft to 40 ft downgradient) 19 out of 60 samples (32%) had HMX below 1.08 µg/L. At the final sampling event, in August, 2015, all of the in-barrier wells and 5/6 centerline wells had HMX below 1.08 µg/L.

Criteria: Overall reduction of RDX concentrations by 95% downgradient of barrier compared to upgradient concentrations.

Assessment: Partial Success

In-barrier wells reached >95% reduction in RDX for 50% of the demonstration period and >99% reduction for 43% of the demonstration period. The averaged centerline wells (from 2.5 to 40 ft downgradient) achieved >95% reduction in RDX for 35% of the demonstration. At the final

sampling event, in August, 2015, all of the in-barrier and centerline monitoring wells had RDX reductions >95%. Similar removal percentages were observed for HMX.

Criteria: Statistically significant difference in RDX concentrations upgradient compared to downgradient of the barrier.

Assessment: Success

One way analysis of variance (ANOVA, with Fishers Least Significant Difference post-hoc) comparing the RDX concentrations in upgradient well MW-1 to in-barrier, centerline, and various groupings of downgradient wells are present in **Table 7.2**. Over the demonstration duration, upgradient RDX concentrations were statistically higher than RDX concentrations in the in-barrier wells, and in the centerline wells ($P < 0.0001$). Upgradient RDX was statistically higher than RDX detected 40 ft downgradient ($P < 0.005$). The same general trends were observed for HMX, with upgradient concentrations statistically higher than downgradient concentrations ($P < 0.0001$) (**Table 7.3**).

Perchlorate Treatment.

Criteria: Reduce perchlorate concentrations to <2 µg/L in at least one downgradient well.

Assessment: Success

The perchlorate concentration data and discussion are presented in detail in Section 6.2.2 above. As with RDX, multiple wells achieved the 2 µg/L perchlorate level during the demonstration. A total of 60 samples out of the 159 samples (38%) collected from the in-barrier and downgradient wells after the initial emulsified oil injection had perchlorate below 2 µg/L. For the in-barrier wells, 17 out of 29 samples (59%) met the perchlorate criteria, while along the centerline (2.5 ft to 40 ft downgradient) 29 out of 60 samples (48%) met the success criteria.

Criteria: Overall reduction of perchlorate concentrations by 95% downgradient of barrier compared to upgradient concentrations.

Assessment: Partial Success

In-barrier wells reached >95% reduction in perchlorate 60% of the demonstration period. The averaged centerline wells (from 2.5 to 40 ft downgradient) achieved >95% reduction in perchlorate for 48% of the demonstration.

Criteria: Statistically significant difference in perchlorate concentrations upgradient compared to downgradient of the barrier.

Assessment: Success

One way analysis of variance (ANOVA, with Fishers Least Significant Difference post-hoc) comparing the perchlorate concentrations in upgradient well MW-1 to in-barrier, centerline, and

various groupings of downgradient wells are present in **Table 7.4**. Over the demonstration duration, upgradient perchlorate concentrations were statistically higher than perchlorate concentrations in the in-barrier wells, and in the centerline wells at the $P < 0.0001$. Upgradient perchlorate concentrations were statistically higher than perchlorate detected 40 ft downgradient ($P < 0.005$). The only outlier was well MW-5 (30 ft downgradient), for which the statistical significance was slightly higher at $P = 0.0781$.

7.2.3 Overall Assessment for RDX and Perchlorate Treatment

Overall, the demonstration successfully met the performance objectives for RDX and perchlorate treatment. Successful treatment of HMX was also observed. The plumes were essentially cutoff by the 100' emulsified oil barrier. The biodegradation of RDX and perchlorate in one area downgradient of the barrier (on the northeast side), constituting wells MW-8, MW-9, PZ-19, and PZ-30 (Figure 5-28) was slower and perchlorate and RDX did not reach the low concentrations observed in other wells. TOC was observed to increase in these wells, but in general, ORP values did not decrease as significantly as in the other wells. It is possible that these wells were partially screened in an interval that was not connected to the upgradient injection wells, and thus the sampled groundwater represented a mixture of treated and untreated water. This would be consistent with the complex geology at this location.

Table 7.2. Statistical analysis output for upgradient vs. downgradient RDX.

One Way ANOVA					
Data Table: Data 1					
Factor A: 12 Groups					
Analysis of Variance Results					
Source	DF	SS	MS	F	P
Total	143	252696	1767		
A	11	67070	6097	4.34	< 0.0001
Error	132	185626	1406		
RDX (µg/L)					
Fisher's Least Significant Difference Comparison	Mean Difference	 t 	P		
Upgradient (MW-10) vs. Avg In-Barrier	76.26	4.98	<0.0001		
Upgradient (MW-10) vs. AVG Centerline	66.33	4.33	<0.0001		
Upgradient (MW-10) vs. IW-1	60.50	3.95	0.0001		
Upgradient (MW-10) vs. IW-8	74.18	4.85	<0.0001		
Upgradient (MW-10) vs. IW-15	94.10	6.15	<0.0001		
Upgradient (MW-10) vs. 2.5 ft (MW-1)	70.16	4.58	<0.0001		
Upgradient (MW-10) vs. 5 ft (MW-2, Dahlgren-04, PZ-19)	69.71	4.55	<0.0001		
Upgradient (MW-10) vs. 10 ft (MW-3, MW-8)	53.45	3.49	0.0007		
Upgradient (MW-10) vs. 20 ft (MW-4, MW-9)	58.66	3.83	0.0002		
Upgradient (MW-10) vs. 30 ft (MW-5)	59.84	3.91	0.0001		
Upgradient (MW-10) vs. 40 ft (MW-6)	50.32	3.29	0.0013		

Table 7.3. Statistical analysis output for upgradient vs. downgradient HMX.

One Way ANOVA					
Data Table: Data for STATS					
Factor A: 12 Groups					
Analysis of Variance Results					
Source	DF	SS	MS	F	P
Total	143	5566	39		
A	11	1598	145	4.83	< 0.0001
Error	132	3967	30		
HMX (µg/L)					
Fisher's Least Significant Difference Comparison	Mean Difference	t	P		
Upgradient (MW-10) vs. Avg In-Barrier	11.30	5.05	<0.0001		
Upgradient (MW-10) vs. AVG Centerline	9.06	4.05	<0.0001		
Upgradient (MW-10) vs. IW-1	9.24	4.13	<0.0001		
Upgradient (MW-10) vs. IW-8	10.75	4.80	<0.0001		
Upgradient (MW-10) vs. IW-15	13.90	6.21	<0.0001		
Upgradient (MW-10) vs. 2.5 ft (MW-1)	10.24	4.57	<0.0001		
Upgradient (MW-10) vs. 5 ft (MW-2, Dahlgren-04, PZ-19)	9.20	4.11	<0.0001		
Upgradient (MW-10) vs. 10 ft (MW-3, MW-8)	6.51	2.91	0.0042		
Upgradient (MW-10) vs. 20 ft (MW-4, MW-9)	6.02	2.69	0.0081		
Upgradient (MW-10) vs. 30 ft (MW-5)	8.39	3.75	0.0003		
Upgradient (MW-10) vs. 40 ft (MW-6)	6.39	2.85	0.0050		

Table 7.4. Statistical analysis output for upgradient vs. downgradient perchlorate.

One Way ANOVA					
Data Table: Data for STATS					
Factor A: 12 Groups					
Analysis of Variance Results					
Source	DF	SS	MS	F	P
Total	143	30538	214		
A	11	9278	843	5.24	< 0.0001
Error	132	21260	161		
PERCHLORATE					
Fisher's Least Significant Difference Comparison	Mean Difference	 t 	P		
Upgradient (MW-10) vs. Avg In-Barrier	25.77	4.97	<0.0001		
Upgradient (MW-10) vs. AVG Centerline	21.22	4.09	<0.0001		
Upgradient (MW-10) vs. IW-1	26.40	5.09	<0.0001		
Upgradient (MW-10) vs. IW-8	22.95	4.43	<0.0001		
Upgradient (MW-10) vs. IW-15	27.99	5.40	<0.0001		
Upgradient (MW-10) vs. 2.5 ft (MW-1)	27.98	5.40	<0.0001		
Upgradient (MW-10) vs. 5 ft (MW-2, Dahlgren-04, PZ-19)	20.25	3.91	0.0001		
Upgradient (MW-10) vs. 10 ft (MW-3, MW-8)	15.31	2.96	0.0037		
Upgradient (MW-10) vs. 20 ft (MW-4, MW-9)	15.32	2.96	0.0037		
Upgradient (MW-10) vs. 30 ft (MW-5)	9.20	1.78	0.0781		
Upgradient (MW-10) vs. 40 ft (MW-6)	16.74	3.23	0.0016		

7.3 ADEQUATE DISTRIBUTION OF EMULSIFIED OIL

Homogeneous oil distribution is important to the success of biobarrier approach for RDX and perchlorate treatment.

7.3.1 Data Requirements for Oil Distribution

The distribution of emulsified oil was quantified by measuring total organic carbon (TOC) increases in the wells installed within the biobarrier. In addition, both TOC and volatile fatty acids (VFAs; breakdown products of emulsified oil) were measured in downgradient monitoring wells. Comparison of TOC levels before and after emulsified oil injection, and in upgradient and downgradient wells, was performed. Particular attention was focused on the wells immediately adjacent to the barrier, 2.5 ft and 5 ft downgradient.

7.3.2 Success Assessment for Oil Distribution

Full details of TOC results are presented in Section 6.1.4 above. As presented in **Table 7.1**, elevated TOC above background levels was observed out to 40 ft downgradient. Summary results are shown below.

TOC Distribution.

Criteria: Observe elevated TOC in downgradient wells.

Assessment: Success

The samples collected after emulsified oil injection indicated that 69% of the wells had TOC levels above the background concentration (conservatively set to 2.5 mg/L). In-barrier wells had elevated TOC levels in 97% of collected samples, whereas centerline wells had elevated TOC in 68% of collected samples. Elevated TOC was detected as far out as 40 ft downgradient from the barrier along the centerline.

VFA Detection.

A full 37% of all samples collected after emulsified oil injection exhibited acetate greater than 2 mg/L. For in-barrier and centerline wells, the percentage of samples with acetate concentrations greater than 2 mg/L was 70% and 37%, respectively. Acetate was detected above background levels (e.g., >2 mg/L) at least 20 ft downgradient of the barrier greater than 30% of the time. Acetate concentrations greater than 100 mg/L were detected up to 10 ft downgradient. Propionate and butyrate were detected less frequently (18% and 13% of all samples, respectively), and at lower concentrations than acetate.

7.3.3 Overall Assessment for Oil Distribution

The performance objective was met based on the TOC and VFA results. The emulsified oil and/or its breakdown products were well distributed through the demonstration plot, and were thus available to promote directly (by serving as an electron donor) or indirectly (by favorable changes to the groundwater chemistry) RDX and perchlorate biodegradation.

7.4 GEOCHEMICAL CHANGES

The addition of emulsified oil as an in situ biobarrier quickly create highly reducing conditions due to microorganisms consuming oxygen, nitrate, and other available electron acceptors during oxidation of oil components. The reducing conditions are necessary for degradation of explosives and perchlorate.

7.4.1 Data Requirements for Geochemical Changes

The parameters that measured to assess creation of favorable geochemical changes were (1) dissolved oxygen (DO) and (2) oxidation-reduction potential (ORP) by field meter. In addition to these parameters, other geochemical parameters were measured including pH (via field meter), anions (via EPA Method 300.0), dissolved gases (e.g., methane; EPA Method 3810) dissolved Fe, Mn, and As (via EPA Method 6010B).

7.4.2 Success Assessment for Geochemical Changes

The success criteria for measured geochemical changes were (1) dissolved O₂ <1 mg/L in all impacted downgradient wells, and (2) ORP reduced to below -100 mV in all wells throughout the demonstration. As summarized in **Table 7.1**, both criteria were met for a reasonable period of the demonstration in most of the emulsified oil impacted wells.

In addition, changes in anions and dissolved metals (Fe, Mn, and As) were used to further verify that reducing conditions were established in the emulsified oil impacted wells.

Finally, perchlorate biodegradation, and to a lesser extent, RDX/HMX biodegradation, are inhibited at low pH. This project also sought to raise the in situ groundwater pH to above 5.5 S.U. by the co-injection of a pH buffer material with the emulsified oil.

DO Levels.

Criteria: DO <1 mg/L in all treatment wells.

Assessment: Success

Full details of results are presented in Section 6.1.2 above. DO levels <1 mg/L were measured in all treatment wells out to 40 ft downgradient more than 51% of the demonstration period. DO was <1 mg/L at 2.5 ft and 5 ft downgradient 89% and 52% of the demonstration period, respectively.

ORP Levels.

Criteria: ORP below -100 mV in all treatment wells.

Assessment: Success

Full details of results are presented in Section 6.1.2 above. ORP levels below -100 mV were detected in all in-barrier and downgradient treatment wells 12% of the demonstration period, and were observed up to 30 ft downgradient at various timepoints. In-barrier wells exhibited ORP below -100 mV for 27% of the demonstration (post-emulsified oil injection).

An ORP of -100 mV is may not necessarily be required for good RDX and perchlorate removal, and RDX and perchlorate removal was observed in wells that did not or rarely reached the -100 mV criteria. Using a higher ORP of -50 mV, all in-barrier and downgradient wells met the criteria

35% of the time, while in-barrier and centerline wells met the criteria 60% and 40% of the demonstration period, respectively.

Anions.

Criteria: Reduced nitrate and sulfate concentrations in treatment wells.

Assessment: Success

Full details of results are presented in Section 6.1.5 above. Nitrate was reduced below background levels (set to 6 mg/L) in 94% of in-barrier and downgradient samples. Sulfate was reduced below background levels (set to 15 mg/L) in 84% of in-barrier and downgradient samples.

Dissolved Gases.

Criteria: Increased concentrations of dissolved methane in treatment wells.

Assessment: Success

Full details of results are presented in Section 6.1.6 above. Methane, and indicator of both labile carbon and deep reducing conditions, were above background levels (conservatively set to 5 µg/L) in 70% of in-barrier and downgradient samples. The only well in which elevated methane was not detected was side gradient well PZ-30.

Dissolved Metals.

Criteria: Increased concentrations of dissolved Fe and Mn in treatment wells.

Assessment: Success

Full details of results are presented in Section 6.3.1 above. Dissolved Fe increased above background levels (set to 500 mg/L) in 76% of in-barrier and downgradient samples. Dissolved Mn increased above background levels (set to 10 mg/L) in 77% of in-barrier and downgradient samples.

pH Levels.

Criteria: Increased pH in treatment wells.

Assessment: Success

Full details of results are presented in Section 6.1.3 above. The pH was increased above a target value of 5.5 S.U. in 56% of in-barrier and downgradient samples.

7.4.3 Overall Assessment for Geochemical Changes

The performance objective was met based on the results obtained. All direct measures (DO, ORP, pH) and indirect measures (anions, dissolved gases, dissolved metals) indicated that conditions favorable for RDX and perchlorate biodegradation were generated within the demonstration plot.

7.5 BARRIER LONGEVITY

The proposed biobarrier for groundwater remediation was expected to remain effective for a minimum of 2 years, based on groundwater flow, electron acceptor concentrations, and other variables.

7.5.1 Data Requirements for Barrier Longevity

The biobarrier longevity was judged based upon (1) the measurement of elevated TOC in the biobarrier wells, and the wells immediately downgradient and (2) reduced concentrations of RDX and perchlorate in the wells immediately downgradient of the barrier.

7.5.2 Success Assessment for Barrier Longevity

Elevated TOC.

Criteria: TOC concentrations in treatment wells remain elevated for two (2) years.

Assessment: Failure

TOC levels above the background were observed in most of the demonstration plot wells for approximately 1 year, but TOC was near background in all wells except IW-15 by Day 498 after injection. Emulsified oil consumption was more rapid than anticipated. A second injection was conducted after approximately 600 days in order to increase TOC levels in the center portion of the demonstration plot. This second injection was effective at increasing TOC and re-establishing conditions conducive to RDX and perchlorate biodegradation.

RDX and Perchlorate.

Criteria: RDX in treatment wells remains below 1.08 µg/L (VA Groundwater Protection Standard) and perchlorate below 2 µg/L for two (2) years.

Assessment: Failure

As summarized in **Table 7.1**, RDX remained below the VA Groundwater Protection Standards in in-barrier well IW-15 for the entire demonstration period (~900 days). RDX decreased at least once below the protection standard within the two year period in downgradient wells MW-2, MW-3, and in-barrier well IW-8. It should be noted that HMX was also below 1.08 µg/L at least once during the two year period in downgradient wells MW-1, MW-2, ME-3, MW-4, MW-5, MW-7, and Dahlgren -04, and in in-barrier wells IW-8 and IW-15

IW-15 and MW-7 remained below 2 µg/L for perchlorate for the entire demonstration period. Several other wells (MW-1, MW-2, MW-3, MW-4, IW-1, IW-8, Dahlgren-04) dropped below 2 µg/L initially, rose above the standard for varying periods after the initial oil injection, and then dropped back down below 2 µg/L after the second emulsified oil injection. MW-6 dropped below 2 µg/L after the second emulsified oil injection.

7.5.3 Overall Assessment for Barrier Longevity

The field results indicated that barrier longevity with was approximately 1 year based on TOC levels and slightly less than two (2) years based on maintaining RDX and perchlorate below our chosen criteria of 1.08 µg/L for RDX and 2 µg/L for perchlorate in treatment wells.

Possible reasons for the shorter treatment period are as follows:

- Groundwater elevations changed appreciably over time in the demonstration plot wells, leaving some upper regions of the aquifer exposed to oxygen for part of the demonstration period. This exposure to oxygen is likely to create a much greater demand for carbon than under saturated conditions.
- Sufficient emulsified oil may not have been added during the initial biobarrier installation to sustain good RDX and perchlorate removal for two (2) years. The initial estimate of the amount of emulsified oil to inject based on the permeable reactive barrier design tool was significantly more than the final amount added, based on discussions with the design tool developer (Dr. Robert Borden) and refinements to the design tool parameters. Because of the nature of the aquifer, with small sand seams and significant areas of impermeable clay, as well as the inability to chase injected emulsified oil with large volumes of water (due to limited range time and slow injection flow rates), we chose to use a lower initial dose of emulsified oil than the design tool recommended in order to avoid potential toxicity to bacterial cells.

7.6 EASE OF BARRIER INSTALLATION

One key objective is to minimize downtime on the active range, so minimizing the time required for biobarrier installation and operation is critical.

7.6.1 Data Requirements for Barrier Installation & Operation

The total length of time for biobarrier installation was recorded. System reliability was evaluated qualitatively by discussions with field personnel and quantitatively by evaluating total downtime for any unplanned activities (e.g., reinjection of emulsified oil, etc.) and total costs of the unplanned activities.

7.6.2 Success Assessment for Barrier Installation & Operation

The injection well installation (20 wells to ~10 ft depth, 100 feet total barrier) required one (1) day, including well finishing with in ground vaults and pipe fittings. Injection well installation was performed several months ahead of the emulsified oil injection to allow collection of baseline samples.

The initial emulsified oil injection required three (3) days, including time for collection of injectate and chaser water from existing wells, mixing of emulsified oil and pH buffer components with water, and introduction into each injection well. The second emulsified oil injection required only two (2) days. No other time requirements were noted for unplanned activities.

7.6.3 Overall Assessment for Ease of Barrier Installation

Barrier installation, oil injection (and re-injection) all required less than five (5) days. All activities were easily completed during range downtimes for other scheduled monitoring well sampling. No impacts on range activities were noted.

8.0. COST ASSESSMENT

8.1 COST MODEL

In order to evaluate the cost of a potential full-scale bioremediation program, and compare it against other remedial approaches, costs associated with various aspects of the demonstration were tracked throughout the course of the project. **Table 8.1** summarizes the various cost elements and total cost of the demonstration project. The costs have been grouped by categories as recommended in the Federal Remediation Technologies Roundtable Guide to Documenting Cost and Performance for Remediation Projects (Federal Remediation Technologies Roundtable, 1998). Many of the costs shown on this table are a product of the innovative and technology validation aspects of this project, and would not be applicable to a typical site application. Therefore, a separate “discounted costs” column that excludes or appropriately discounts these costs has been included in **Table 8.1** to provide a cost estimate for implementing this technology at the same scale as the demonstration (i.e., pilot scale).

Costs associated with the in situ bioremediation of energetic compounds demonstration were tracked from March 2011 to November 2015. The total cost of the demonstration was \$865,100, which included \$64,600 in capital costs, \$313,300 in operation and maintenance (O&M) costs, and \$487,400 in demonstration-specific costs (cost related to ESTCP requirements, site selection and characterization). A total of approximately 930 cubic yards, or 47000 gallons (assuming a 25% soil porosity) of contaminated aquifer were treated during the demonstration. This corresponds to a unit cost of approximately \$930 per cubic yard or \$18 per gallon of contaminated aquifer (**Table 8.1**). By excluding an estimated \$595,200 of research-oriented costs (primarily the costs associated with the installation and sampling of extra monitoring wells, molecular biology studies, and ESTCP reporting requirements), unit costs are estimated at approximately \$216 per cubic yard, or \$4 per gallon of contaminated aquifer for a project of this scale (**Table 8.1**).

Table 8.1. Demonstration cost components.

Cost Element	Details	Tracked Demonstration Costs	Discounted Costs¹
CAPITAL COSTS			
Groundwater Modeling	Labor	\$1,400	\$1,400
System Design	Labor	\$5,400	\$5,400
Well Installation, Development & Surveying ²	Labor	\$12,600	\$12,600
	Materials	\$200	\$4,000
	Subcontracts (driller/surveyor)	\$36,200	\$12,000
System Installation (EVO mixing and injection system)	Labor	\$4,500	\$4,500
	Equipment & Materials	\$2,500	\$2,500
	Subcontracts (electrical, Conex box/PLC)	\$0	\$0
Travel		\$1,600	\$1,600
Subtotal		\$64,400	\$44,000
OPERATION AND MAINTENANCE COSTS			
Groundwater Sampling ³	Labor	\$96,400	\$12,000
	Materials	\$6,000	\$2,500
Analytical	In-House Labor	\$62,000	\$3,800
	Outside Labs (metals & explosives ²)	\$16,000	\$12,500
System O&M (including testing & start-up)	Labor	\$68,500	\$48,000
	Materials (EVO, consumables)	\$7,200	\$7,200
Utilities	Electric	\$600	\$600
Reporting & Data Management	Labor	\$52,400	\$24,000
Travel		\$4,200	\$4,200
Subtotal		\$313,300	\$114,800
OTHER TECHNOLOGY-SPECIFIC COSTS			
Site Selection	Labor & Travel	\$19,200	\$0
Site Characterization (surface soil investigation, 2 direct-push investigations, installation of 2 monitoring wells, slug tests, pump tests)	Labor (including in-house analytical)	\$111,600	\$0
	Materials	\$1,800	\$0
	Subcontractor (driller)	\$36,200	\$0
Laboratory Microcosm and Column Testing	Labor (including in-house analytical)	\$111,700	\$0
Molecular Biology Studies	Labor (including in-house analytical)	\$28,900	\$0
	Outside Lab	\$38,800	\$0
IPR Meeting & Reporting	Labor & Travel	\$16,700	\$0
Technology Transfer (presentations, papers)	Labor & Travel	\$37,100	\$0
Demonstration Plan/Work Plan	Labor	\$22,200	\$10,000
Final Report	Labor	\$55,200	\$32,000
Cost and Performance Report	Labor	\$8,000	\$0
Subtotal		\$487,400	\$42,000
TOTAL COSTS		\$865,100	\$200,800
ESTIMATED TREATMENT VOLUME (cubic yards)		930	930
ESTIMATED TREATMENT VOLUME (gallons)		47,000	47,000
APPROXIMATE TREATMENT COST (per cubic yard)		\$930.22	\$215.91
APPROXIMATE TREATMENT COST (per gallon)		\$18.41	\$4.27

Notes:

¹Discounted costs are defined as estimated costs to implement this technology at the same scale as the demonstration. These costs do not include the technology validation aspects of the demonstrations, such as site selection, some laboratory testing, stable isotope studies, molecular biology studies, extensive groundwater sampling, demonstration reporting, interim progress reviews, and preparation of technical and cost and performance reports.

²Includes 20 injection wells. Fourteen additional monitoring wells were installed for demonstration. Three monitoring wells are assumed for discounted costing.

³ Two baseline and ten performance monitoring events were performed during the demonstration. Five sampling events are assumed for discounted costing.

8.1.1 Capital Costs

Capital costs (primarily system design and installation) accounted for \$64,600 (or 7 percent) of the total demonstration costs. As indicated in **Table 8.1**, these costs exceed what would be expected during a typical remediation project due partially to the large number of performance monitoring wells (14) installed within the relatively small (100 x 100') demonstration area.

8.1.2 O&M Costs

O&M costs accounted for \$313,300 (or 36 percent) of the total demonstration cost. These costs consisted primarily of groundwater monitoring (including analytical), systems O&M, and reporting costs. System O&M costs were \$75,700, or 9 percent of total demonstration costs. The cost of the 990 pounds of EVO added during the demonstration was \$2,500, or 0.3 percent of total demonstration costs. Treatment dosage during the demonstration is estimated at approximately 1.0 pounds of EVO per cubic yard of treated aquifer. Extensive performance monitoring activities were conducted to effectively validate this technology; including 12 groundwater sampling events (2 baseline and 10 performance).

8.1.3 Demonstration-Specific Costs

Other demonstration-specific costs (those costs not expected to be incurred during non-research-oriented remediation projects) accounted for \$487,400 (or 56 percent) of the total demonstration cost. These costs included site selection, laboratory treatability studies, molecular biology studies, ESTCP demonstration reporting and meeting (IPR) requirements, and preparation of extensive technical and cost and performance reports.

8.2 COST DRIVERS

8.2.1 General Considerations

The expected cost drivers for installation and operation of a passive groundwater recirculation and amendment delivery system for the remediation of explosives contaminated groundwater, and those that will determine the cost/selection of this technology over other options include the following:

- Depth of the plume below ground surface;
- Width, length, and thickness of the plume;
- Aquifer lithology and hydrogeology;
- Regulatory/acceptance of groundwater extraction and re-injection;
- Regulatory considerations concerning secondary groundwater impacts (i.e. metals mobilization, sulfate reduction, etc.);
- Length of time for clean-up (e.g., necessity for accelerated clean-up);
- The presence of indigenous bacteria capable of degrading explosive compounds;
- Concentrations of contaminants and alternate electron acceptors (e.g., NO_3^- , SO_4^{2-} and O_2);
- Presence of co-contaminants, such as chlorinated ethenes, or chlorinated ethanes;
- The type(s) of co-substrates determined to be effective at promoting the biodegradation of explosive compounds at a given site (i.e. those that are packaged in soluble form vs. those that need to be mixed into solution prior to injection); and
- O&M costs.

As discussed in detail in Section 5.1, microcosm screening and column treatability testing showed that a combination of emulsified oil and colloidal buffer was the most effective substrate for

promoting biological reduction of RDX, and suggested that this combination would be effective in the field for RDX as well. The EOS 550LS emulsified oil and CoBupH buffer combination were chosen as the amendments for field injection based on the laboratory tests and product availability. Costs associated with the design and procurement of the injection system used to mix and inject the substrate was relatively insignificant because little equipment was required.

8.2.2 Competing Treatment Technologies

The three other technologies (in addition to bioremediation using a carbon source such as EVO) that have been proven to treat perchlorate and nitroaromatic explosives, such as RDX in groundwater, to below regulatory levels at the field scale include:

1. Pump and treat (P&T) with standard and/or tailored GAC (Parette *et al.*, 2005)
2. Zero valent iron permeable reactive barriers (ZVI PRBs), and
3. Mulch biowall

Additional technologies, including in situ chemical oxidation using permanganate (Albano *et al.*, 2010), an electrolytic barrier (ESTCP Project ER-0519; www.SERDP.org) and in situ treatment wells (ISTWs) with granular iron placed outside of the well screens (ESTCP Project ER-0223; www.SERDP.org), have been tested at the field scale, but have failed to consistently reduce concentrations to below regulatory levels of concern.

Pump and treat technologies provide capture of contaminated groundwater, and above-ground treatment of the extracted water prior to discharge or re-injection into the subsurface. While these systems can provide protection to downgradient receptors if designed properly, they are inefficient at removing contaminant mass from a plume and/or source zone, and often require operation for decades, leading to high overall costs.

ZVI PRBs, mulch biowalls, and EVO biobarriers treat contaminated groundwater as it flows through the wall/barrier. While these approaches can provide protection to downgradient receptors, they are even less effective than P&T at removing contaminant mass from the plume and/or source zone. They may also require regular replacement as the materials (ZVI, mulch, or EVO) are used up or begin to clog, leading to contaminated groundwater flowing around or beneath the wall/barrier.

As previously discussed, bioremediation approaches can be either “active”, where distribution of amendments is achieved using groundwater recirculation, or “passive”, where distribution is accomplished during initial injection and/or via ambient groundwater flow (see Stroo and Ward, 2009). Active groundwater treatment approaches often involve pairs or groups of injection and extraction wells to recirculate groundwater and effectively distribute injected amendments within the subsurface. Passive treatment approaches generally involve injection of amendments via closely-spaced injection wells or direct-push technology. A hybrid “semi-passive” approach has also been tested, where groundwater is recirculated for a short period to distribute amendments, followed by a longer period of no groundwater recirculation (Hatzinger and Lippincott, 2012). In each of the above three approaches, a carbon source is typically added in order to promote and maintain the reducing, anoxic conditions and supply carbon needed for in situ growth of bacteria

capable of degrading target contaminants. A slow-release carbon source such as EVO is often utilized with passive treatment approaches to reduce injection frequency.

Bioremediation (either active, passive, or semi-passive approaches) can be utilized to treat source areas and diffuse plumes or as a barrier to protect downgradient receptors, whereas the three technologies discussed above (P&T, ZVI PRBs, and mulch biowalls) are typically used as barriers to protect downgradient receptors. When a bioremediation approach is used to treat contaminated groundwater clean-up times are generally substantially shorter than those associated with P&T, ZVI PRBs and mulch biowalls.

The plume characteristics and those of the local aquifer will play an important role in the cost and applicability of the above technologies for remediation of perchlorate and explosives-contaminated groundwater. For shallow groundwater plumes (less than 50 ft bgs), passive in situ options, such as installation of a PRB consisting of either injection well or direct-push applied slow-release substrates (like EVO), are likely to be a cost effective options, providing the selected substrate(s) have been shown to stimulate indigenous microorganisms capable of degrading target contaminants at the treatment site. Trench installation of mulch biowalls or ZVI PRBs may also provide cost-effective options for passively treating contaminants at the downgradient edge of groundwater plumes. For perchlorate, the a ZVI PRB is likely to promote biotic (via production of hydrogen as an electron donor) rather than abiotic degradation, as kinetics of abiotic perchlorate degradation with ZVI are very slow (Gurol and Kim, 2000; Son *et al.*, 2006). These passive systems require little O&M after installation, and have the ability to prevent plumes from spreading or leaving a site. However, they may be less suitable at sites where concerns about secondary groundwater contaminants (e.g. reduction and mobilization of Fe, Mn and As, sulfide from sulfate reduction, etc.) exist. Additionally, trench-installed barrier technologies may require ZVI replacement (ZVI PRBs) or regular rejuvenation with injections (mulch PRBs) to remain effective.

For deeper plumes (e.g. >50 ft. bgs) or those that are large or very thick, passive approaches are often not technically feasible and are cost-prohibitive (e.g., injecting passive substrates at closely spaced intervals to greater than 50 ft bgs). Active or semi-passive treatment systems may be technically and economically more attractive under these conditions. Active or semi-passive treatment approaches may also be better suited for heterogeneous geologies or sites where pH adjustment is required, as groundwater recirculation improves mixing and distribution of injected amendments within the subsurface. Longer treatment time frames, high contaminant concentrations, and secondary reactions may also present conditions favorable for utilizing an active approach, since amendment addition and mixing rates can be adjusted more easily than with passive approaches which often utilize less frequent injection of amendments at high concentrations. However, these approaches may be limited where re-injection of contaminated water with amendments is either prohibited due or subject to regulatory injection permits.

8.3 COST ANALYSIS

A thorough cost analysis of various in situ treatment approaches, including active-pumping systems, passive systems, and semi-passive designs is provided in *In situ Bioremediation of Perchlorate in Groundwater* (Krug *et al.*, 2009). These approaches are compared technically and economically with each other and with *ex situ* treatment under a variety of different contamination scenarios. The reader is referred to this chapter and others in this volume for descriptions and

economic comparisons of different in situ technologies that have shown to be capable of remediating perchlorate in groundwater. The base case and cost analysis presented in the publication referenced above were used as a template for the cost analysis of the technology tested during this demonstration, as well as the other technologies discussed above that have been proven effective at treating explosives contaminated groundwater. A cost analysis for the base case was performed for the following technologies:

1. Semi-passive biobarrier with EVO
2. Passive injection biobarrier with cheese whey
3. Passive trench mulch biowall with EVO (for additional TOC)
4. Passive trench ZVI PRB
5. Active pump and treat

The cost analyses comparing the above approaches are presented below based on a 30-year operating scenario.

8.3.1 Base Case Template

As discussed above, the general base case presented in Krug et al., (2009) is used as a template for the cost analysis of the above technologies/approaches. The base case presents a situation where a shallow aquifer, consisting of homogeneous silty sands, is contaminated with perchlorate (and for the case of this analysis RDX). The explosives-impacted groundwater extends from 10 to 40 feet bgs, along the direction of groundwater flow for 800 feet, and is 400 feet in width (**Figure 8.1**). The specific base case site characteristics, including aquifer characteristics and design parameters for each of the remedial approaches analyzed are summarized in **Table 8.2**. The costing for the template site assumes that the source zone has been treated and that there is no continuing source of groundwater contamination.

As indicated in **Table 8.2**, the base case assumes a groundwater seepage velocity of approximately 33 ft/year, and that two pore volumes of clean water will need to flush through the impacted area to achieve the cleanup objectives. However, as stated in Krug et al., (2009), there are a number of factors, such as the degree of heterogeneity of the geological media that will determine the actual number of pore volumes of clean water required to flush through the subsurface to achieve target treatment objectives. Variations in the hydraulic conductivity (K) of the aquifer materials can allow a significant fraction of the total mass of contaminants to diffuse into low K layers, and then act as an ongoing source to the higher K zones. In most geological settings, it is likely that more than two pore volumes would be required to achieve treatment objectives, thus leading to longer treatment times (and costs) for passive and P&T approaches.

The following subsections provide cost estimates for implementation of each the six treatment approaches for the base case. The cost estimates provide insight into the comparative capital, O&M, and long term monitoring costs to better identify cost drivers for each technology/ approach. Total costs and the Net Present Value (NPV) of future costs were calculated for each of treatment approaches. Future costs (O&M and long term monitoring costs) are discounted, using a 2% discount rate, to determine the NPV estimates of these costs (Office of Management and Budget, 2012). Specifically excluded from consideration are the costs of pre-remedial investigations and treatability studies, assuming the costs for these activities would be similar for each alternative.

Table 8.2. Summary of base case site characteristics and design parameters for treatment of explosives-impacted groundwater.

Design Parameter	Units					
		Semi-Passive Biobarrier (EVO)	Passive Injection Biobarrier (EVO)	Passive Trench Mulch Biowall (EVO)	Passive Trench ZVI PRB	Active Pump and Treat
Width of Plume	feet	400	400	400	400	400
Length of Plume	feet	800	800	800	800	800
Depth to Water	feet	10	10	10	10	10
Vertical Saturated Thickness	feet	40	40	40	40	40
Porosity	dimensionless	0.25	0.25	0.25	0.25	0.25
Gradient	dimensionless	0.008	0.008	0.008	0.008	0.008
Hydraulic Conductivity	ft/day	2.8	2.8	2.8	2.8	2.8
Groundwater Seepage Velocity	ft/year	33	33	33	33	33
Upgradient Combined Perchlorate & RDX Concentration	µg/L	2,000	2,000	2,000	2,000	2,000
Downgradient Combined Perchlorate & RDX Concentration	µg/L	10	10	10	10	10
Nitrate Concentration	mg/L	15	15	15	15	15
Dissolved Oxygen Concentration	mg/L	5	5	5	5	5
TNT Treatment Objective	µg/L	2	2	2	2	2
RDX Treatment Objective	µg/L	2	2	2	2	2
Assumed Number of Pore Volumes to Flush Plume	each	2	2	2	2	2
Number of Barriers	each	1	1	1	1	NA
Number of Monitoring Wells	each	10	10	10	10	10
Number of Amendment Injection Wells	each	0	30	20	0	0
Number of Groundwater Extraction Wells	each	4	0	0	0	4
Number of Groundwater Re-Injection Wells	each	5	0	0	0	0
Groundwater Travel Time to Barrier	years	24	24	24	24	NA
Years to Clean Up Groundwater	years	48	48	48	48	NA

NA - Not Applicable

Figure 8.1. Base case plume characteristics (modified from Krug et al., 2009).

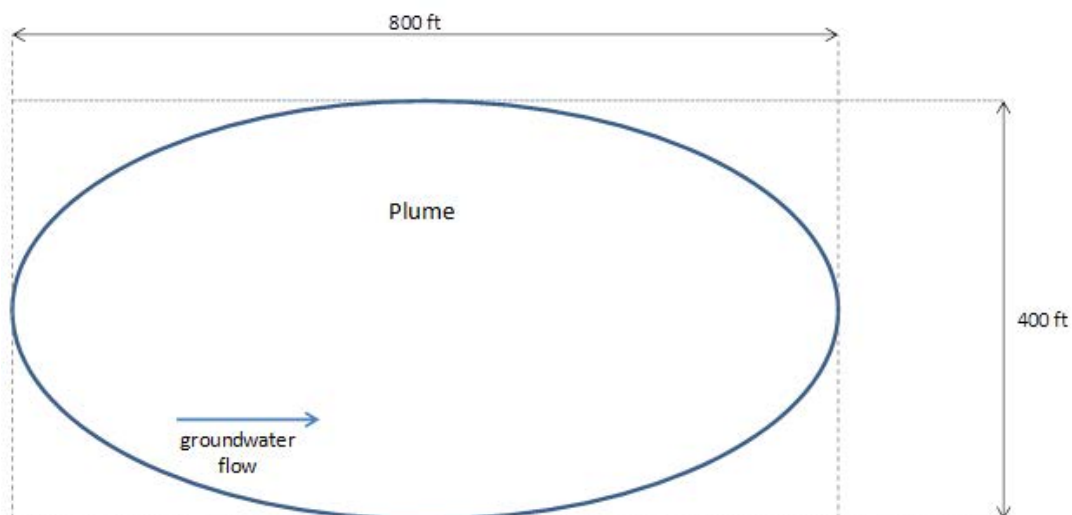

8.3.2 Semi-Passive Biobarrier

The semi-passive biobarrier alternative assumes that a series of four extraction and five injection wells will be installed at the downgradient edge and perpendicular to the axis of the plume (**Figure 8.2**). Groundwater will be recirculated between the rows of wells, and soluble cheese whey added for approximately 3 weeks, after which time the system will be shut down for a period of 9 months. The biobarrier will be operated in this semi-passive mode for a period of 30 years. This alternative also assumes 30 years of associated O&M and long term monitoring costs.

As summarized in **Table 8.3**, the estimated total costs for this alternative over 30 years are \$2,430,000 with a total NPV of lifetime costs of \$1,990,000. The capital cost including design, work plan, installation of recirculation and monitoring wells, construction of the groundwater recirculation and cheese whey mixing systems, and system start up and testing are approximately \$500,000. The NPV of the O&M is estimated at approximately \$1,060,000 for the 30 years of treatment. The O&M costs include the labor costs associated with regular rounds (every 9-10 months) of whey mixing and injection, labor for system O&M, costs for equipment repair and replacement, and cost for EVO. The NPV of the 30 years of monitoring and reporting costs is estimated to be \$430,000.

This alternative ranks second in estimated total remedy cost and second in NPV of lifetime costs (see **Table 8.8**). While this technology has relatively modest estimated capital costs, the long term O&M costs make it less attractive, especially if the system needs to operate beyond 30 years.

Figure 8.2. Semi-passive biobarrier alternative with cheese whey for plume cutoff.

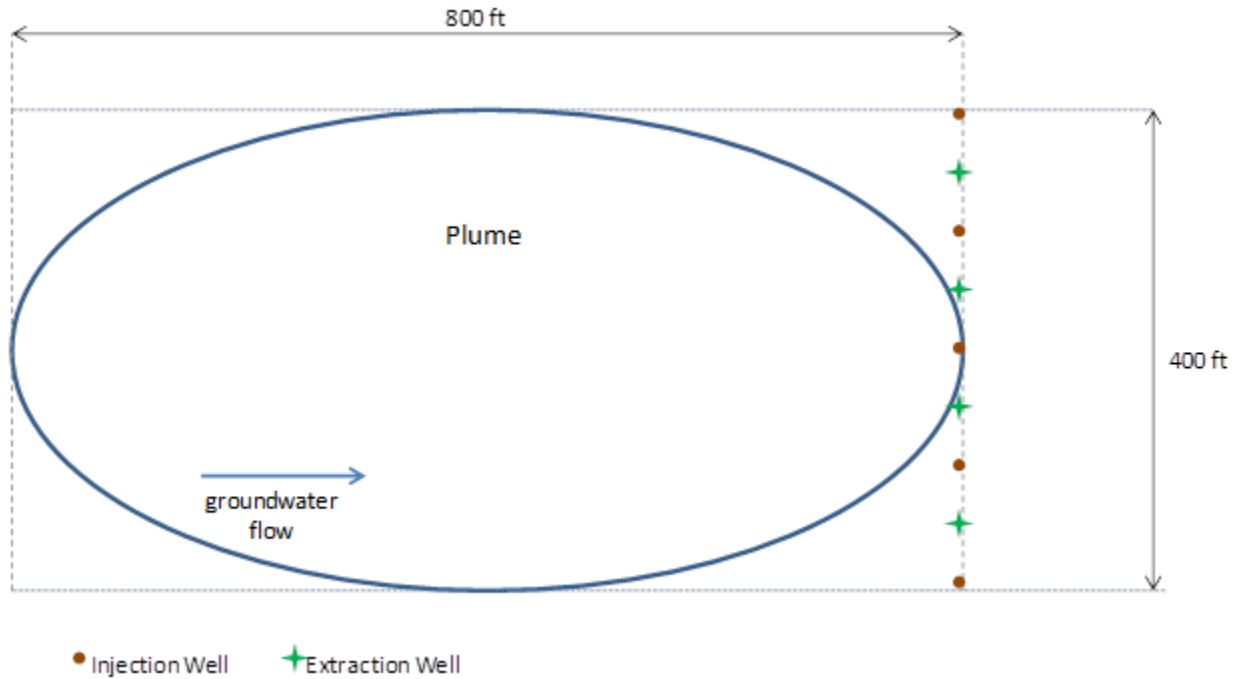

Table 8.3. Cost components for semi-passive biobarrier treatment of explosives-impacted groundwater.

	Year Cost is Incurred							NPV of Costs*	Total Costs
	1	2	3	4	5	6	7 to 30		
CAPITAL COSTS									
System Design	102,943	-	-	-	-	-	-	102,943	102,943
Well Installation	87,359	-	-	-	-	-	-	87,359	87,359
System Installation	287,790	-	-	-	-	-	-	287,790	287,790
Start-up and Testing	19,452	-	-	-	-	-	-	19,452	19,452
SUBCOST (\$)	497,544							497,544	497,544
OPERATION AND MAINTENANCE COSTS									
System Operation and Maintenance	30,007	47,048	47,048	47,048	47,048	47,048	42,482 every year	1,057,741	1,394,399
SUBCOST (\$)	30,007	47,048	47,048	47,048	47,048	47,048		1,057,741	1,394,399
LONG TERM MONITORING COSTS									
Sampling/Analysis/Reporting (Quarterly through 5 years then Annually)	40,036	40,036	40,036	40,036	40,036	13,383	12,369 every year	433,872	534,762
SUBCOST (\$)	40,036	40,036	40,036	40,036	40,036	13,383		433,872	534,762
TOTAL COST (\$)	567,587	87,084	87,084	87,084	87,084	60,431		1,989,158	2,426,706

Notes:

NPV - Net Present Value

* - NPV calculated based on a 2% discount rate

8.3.3 Passive Injection Biobarrier

The passive injection biobarrier alternative assumes that a series of 30 injection wells will be installed at the downgradient edge and perpendicular to the axis of the plume (**Figure 8.3**). An initial injection during year 1, and reinjection of EVO every 3 years after, will be performed to create a passive biobarrier. The biobarrier will be maintained for a period of 30 years. This alternative also assumes 30 years of associated O&M and long term monitoring costs.

As summarized in **Table 8.4**, the estimated total costs for this alternative over 30 years are \$2,580,000 with a total NPV of lifetime costs of \$2,060,000. The capital cost including design, work plan, installation of injection and monitoring wells, and the initial EVO injection are approximately \$390,000. The NPV of the O&M is estimated at approximately \$1,280,000 for the 30 years of treatment. The O&M costs primarily include the labor and material costs associated with regular injections (every 3 years) of EVO. The NPV of the 30 years of monitoring and reporting costs is estimated to be \$430,000.

This alternative ranks fourth in estimated total remedy cost and third in NPV of lifetime costs (see **Table 8.8**). The estimated capital costs for this approach are the lowest of the five alternatives because of the limited infrastructure required. However, the long term O&M costs associated with regular injections of EVO make this one of the more expensive alternatives, with total remedy costs second only to the pump and treat alternative. As with the other barrier approaches (including pump and treat), total remedy costs will increase if the treatment needs to extend beyond 30 years.

Figure 8.3. Passive injection biobarrier alternative with EVO for plume cutoff.

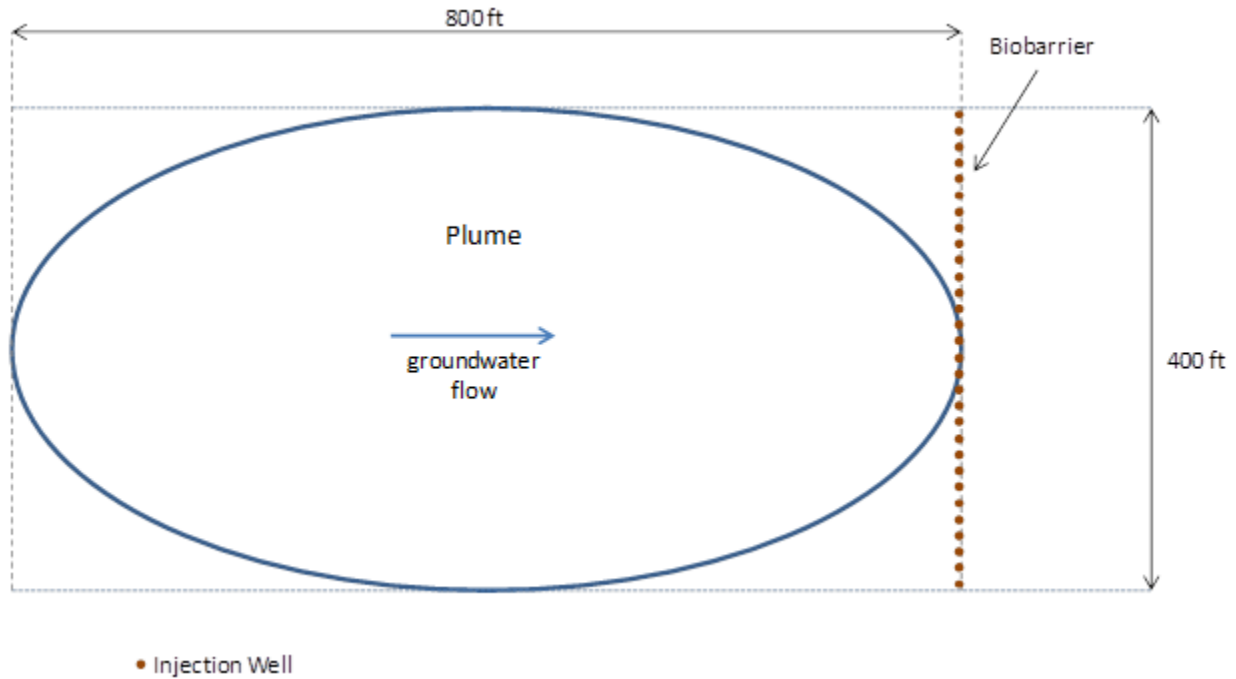

Table 8.4. Cost components for passive injection biobarrier treatment of explosives-impacted groundwater.

	Year Cost is Incurred								NPV of Costs*	Total Costs	
	1	2	3	4	5	6	7	8 to 30			
CAPITAL COSTS											
System Design	77,368	-	-	-	-	-	-	-	-	77,368	77,368
Well Installation (30 1" PVC Wells)	72,919	-	-	-	-	-	-	-	-	72,919	72,919
Substrate Injection	199,708	-	-	-	-	-	-	-	-	199,708	199,708
Start-up and Testing**	-	-	-	-	-	-	-	-	-	0	0
SUBCOST (\$)	349,996									349,996	349,996
OPERATION AND MAINTENANCE COSTS											
Substrate Injection	-	-	-	188,915	-	-	188,915	174,598 every 3 years	1,278,215	1,700,237	
SUBCOST (\$)				188,915			188,915		1,278,215	1,700,237	
LONG TERM MONITORING COSTS											
Sampling/Analysis/Reporting (Quarterly through 5 years then Annually)	40,036	40,036	40,036	40,036	40,036	13,383	13,383	12,369 every year	433,872	534,762	
SUBCOST (\$)	40,036	40,036	40,036	40,036	40,036	13,383	13,383		433,872	534,762	
TOTAL COST (\$)	390,032	40,036	40,036	228,951	40,036	13,383	202,299		2,062,083	2,584,995	

Notes:

NPV - Net Present Value

* - NPV calculated based on a 2% discount rate

** - No "Start-up and Testing" costs are included because no operating equipment is left behind following substrate injection

8.3.4 Passive Trench Mulch Biowall

The passive trench mulch biowall alternative assumes an initial installation of a mulch biowall in a trench at the downgradient edge and perpendicular to the axis of the plume (**Figure 8.4**). The mulch biowall will be installed using the one-pass trenching/installation method, and will be 400 feet long, 2 feet thick, and extend down to 40 feet bgs. The biowall will be rejuvenated 4 and 8 years after installation, and then every 3 years thereafter by injecting EVO into 20 injection wells installed within the mulch biowall. The EVO injections are required because the organics in the mulch will eventually be depleted. The biowall will be maintained for a period of 30 years. This alternative also assumes 30 years of associated O&M and long term monitoring costs.

As summarized in **Table 8.5**, the estimated total costs for this alternative over 30 years are \$2,350,000 with a total NPV of lifetime costs of \$1,860,000. The capital cost including design, work plan, mulch biowall installation, and installation of injection and monitoring wells are approximately \$390,000. The NPV of the O&M is estimated at approximately \$1,040,000 for the 30 years of treatment. The O&M costs primarily include the labor and material costs associated with injections of EVO to maintain the biowall. The NPV of the 30 years of monitoring and reporting costs is estimated to be \$430,000.

This alternative ranks lowest in estimated total remedy cost and lowest in NPV of lifetime costs (see **Table 8.8**). The estimated capital costs for this approach are higher than those of the passive injection biobarrier, because of the higher costs associated with the construction of the trench biowall relative to the costs for the initial injection of EVO. However, the long term O&M costs associated with maintaining the mulch biowall are less than those of the passive injection biobarrier, because less frequent injections (and less quantity) of EVO will be required to maintain the mulch biowall, relative to the passive injection biobarrier. As with the other barrier approaches (including pump and treat), total remedy costs will increase if the treatment extends beyond 30 years.

Figure 8.4. Passive biobarrier alternative utilizing a mulch biowall for plume cutoff.

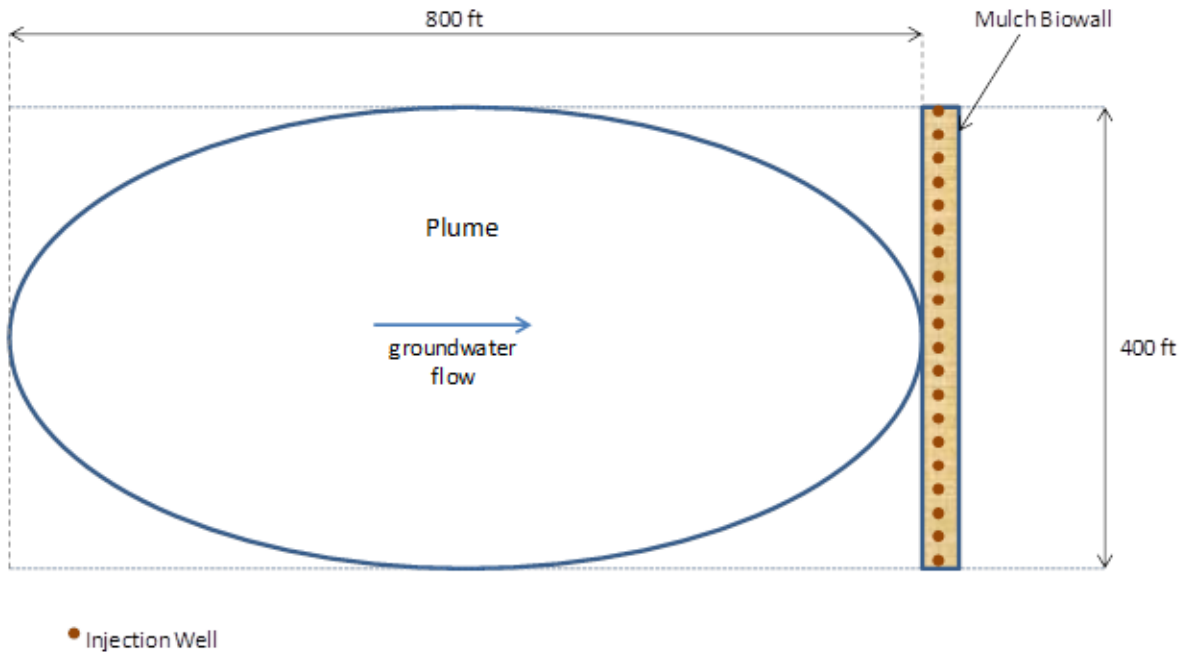

Table 8.5. Cost components for passive trench biowall treatment of explosives-impacted groundwater.

	Year Cost is Incurred									NPV of Costs*	Total Costs	
	1	2	3	4	5	6	7	8	9 to 30			
CAPITAL COSTS												
System Design	70,552	-	-	-	-	-	-	-	-	-	70,552	70,552
Well Installation	57,415	-	-	-	-	-	-	-	-	-	57,415	57,415
Trench Installation	206,676	-	-	-	-	-	-	-	-	-	206,676	206,676
Substrate Injection	56,805	-	-	-	-	-	-	-	-	-	56,805	56,805
Start-up and Testing**	-	-	-	-	-	-	-	-	-	-	0	0
SUBCOST (\$)	391,448										391,448	391,448
OPERATION AND MAINTENANCE/REAPPLICATION COSTS												
	-	-	-	157,937	-	-	-	157,937	145,968 every 3 years		1,035,595	1,421,435
SUBCOST (\$)	-	-	-	157,937	-	-	-	157,937			1,035,595	1,421,435
LONG TERM MONITORING COSTS												
Sampling/Analysis/Reporting (Quarterly through 5 years then Annually)	40,036	40,036	40,036	40,036	40,036	13,383	13,383	13,383	12,369 every year		433,872	534,762
SUBCOST (\$)	40,036	40,036	40,036	40,036	40,036	13,383	13,383	13,383			433,872	534,762
TOTAL COST (\$)	431,484	40,036	40,036	197,973	40,036	13,383	13,383	171,320			1,860,915	2,347,645

Notes:

NPV - Net Present Value

* - NPV calculated based on a 2% discount rate

** - No "Start-up and Testing" costs are included because no operating equipment is left behind following substrate injection

8.3.5 Passive Trench ZVI PRB

The passive trench ZVI PRB alternative assumes an initial installation of a ZVI PRB in a trench at the downgradient edge and perpendicular to the axis of the plume (**Figure 8.5**). The PRB will consist of 25% ZVI filings and 75% coarse sand fill mixture (v/v). Like the passive mulch biowall, the PRB will be installed using the one-pass trenching/installation method, and will be 400 feet long, 2 feet thick, and extend down to 40 feet bgs. Pricing for this alternative assumes the PRB will need to be replaced after 15 years, due to decline in ZVI reactivity and/or plugging. The PRB will be maintained for a period of 30 years. This alternative also assumes 30 years of associate O&M and long term monitoring costs.

As summarized in **Table 8.6**, the estimated total costs for this alternative over 30 years are \$2,390,000 with a total NPV of lifetime costs of \$2,080,000. The capital cost including design, work plan, ZVI PRB installation, and installation of monitoring wells are approximately \$1,010,000. The NPV of the O&M is estimated at approximately \$640,000, which is the NPV associated with the replacement of the PRB after 15 years. The NPV of the 30 years of monitoring and reporting costs is estimated to be \$430,000.

This alternative ranks third in estimated total remedy cost and fourth in NPV of lifetime costs (**Table 8.8**). The estimated capital costs for this approach are higher than those of the passive trench mulch biowall, because of the much higher costs associated with ZVI PRB material relative to the costs for the mulch biowall material. However, the long term O&M costs associated with maintaining the ZVI PRB are less than those of the mulch biowall, because no additional EVO injections are required to maintain the ZVI PRB. The total remedy costs for this alternative would increase significantly if the PRB lifespan was less than 15 years, or if treatment extended beyond 30 years.

Figure 8.5. Passive permeable reactive barrier alternative utilizing ZVI for plume cutoff.

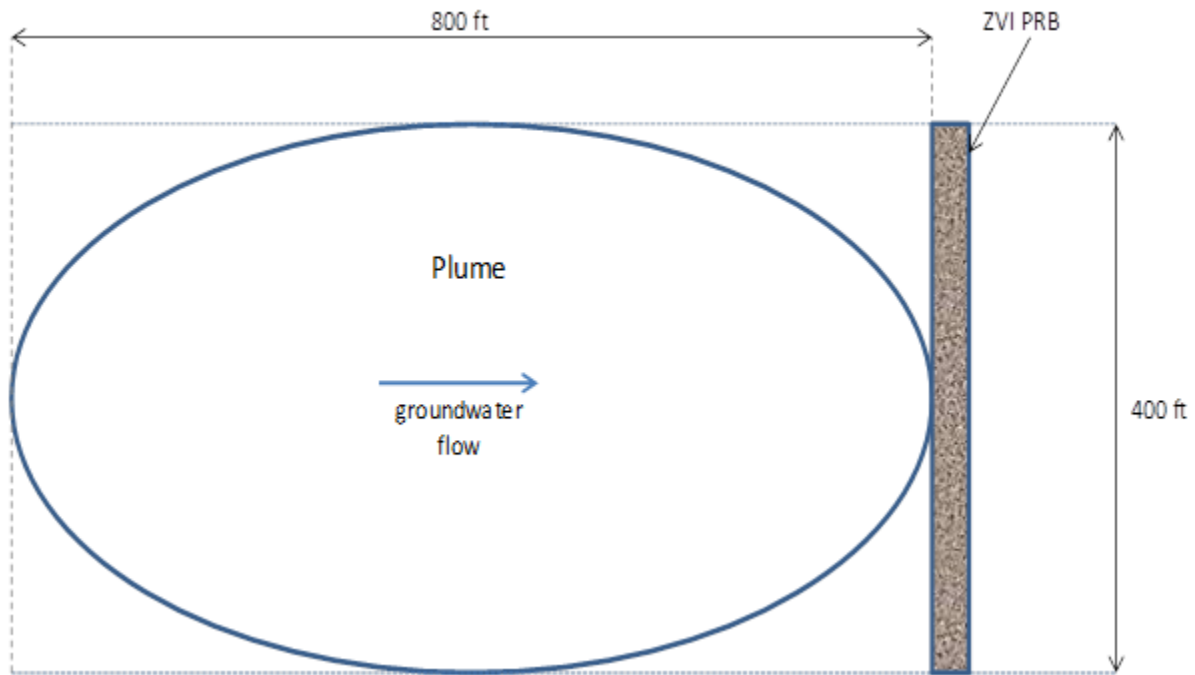

Table 8.6. Cost components for passive trench ZVI PRB treatment of explosives-impacted groundwater.

	Year Cost is Incurred							NPV of Costs*	Total Costs
	1	2	3	4	5 to 14	15	16 to 30		
CAPITAL COSTS									
System Design	70,552	-	-	-	-	-	-	70,552	70,552
Well Installation	31,469	-	-	-	-	-	-	31,469	31,469
Trench Installation	206,676	-	-	-	-	-	-	206,676	206,676
PRB Material	703,300	-	-	-	-	-	-	703,300	703,300
Start-up and Testing**	-	-	-	-	-	-	-	0	0
SUBCOST (\$)	1,011,996	-	-	-	-	-	-	1,011,996	1,011,996
OPERATION AND MAINTENANCE/REAPPLICATION COSTS									
PRB Replacement Cost	-	-	-	-	-	841,013	-	637,383	841,013
SUBCOST (\$)	-	-	-	-	-	841,013	-	637,383	841,013
LONG TERM MONITORING COSTS									
Sampling/Analysis/Reporting (Quarterly through 5 years then Annually)	40,036	40,036	40,036	40,036	12,369 every year	13,383	12,369 every year	433,872	534,762
SUBCOST (\$)	40,036	40,036	40,036	40,036		13,383		433,872	534,762
TOTAL COST (\$)	1,052,033	40,036	40,036	40,036		854,396		2,083,251	2,387,772

Notes:

NPV - Net Present Value

* - NPV calculated based on a 2% discount rate

** - No "Start-up and Testing" costs are included because no operating equipment is left behind following substrate injection

8.3.6 Active Pump and Treat

The groundwater extraction and treatment (pump and treat) system alternative would be similar to the semi-passive biobarrier system, in that a row of four extraction and five injection wells would be used to recirculate groundwater at the downgradient edge and perpendicular to the axis of the plume (**Figure 8.2**). However, in this case, the extracted groundwater would be treated above ground by passing it through a combination of standard GAC and a tailored GAC that adsorbs perchlorate more effectively (Parette *et al.*, 2005). The treated groundwater re-injected (providing hydraulic control and mass removal at the downgradient edge of the plume). The pump and treat system will be maintained for a period of 30 years. This alternative also assumes 30 years of associated O&M and long term monitoring costs.

As summarized in **Table 8.7**, the estimated total costs for this alternative over 30 years are \$3,620,000 with a total NPV of lifetime costs of \$2,910,000. The capital cost including design, work plan, installation of extraction/injection and monitoring wells, construction of the groundwater treatment system, and system start up and testing are approximately \$550,000. The NPV of the O&M is estimated at approximately \$1,930,000. The O&M costs include the labor costs associated with system O&M, costs for equipment repair and replacement, electrical costs, and cost for the replacement and disposal of the GAC. The NPV of the 30 years of monitoring and reporting costs is estimated to be \$430,000.

This alternative ranks last in both estimated total remedy cost and NPV of lifetime costs (**Table 8.8**). The estimated capital costs for this alternative are higher than those of the semi-passive alternative because of the higher costs associated with constructing a groundwater treatment system, compared to constructing an EVO delivery system. The high O&M costs associated with operating the pump and treat system are what makes this alternative the least attractive of the six alternatives. As with the other barrier approaches, total remedy costs will increase if the treatment needs to extend beyond 30 years.

Table 8.7. Cost components for extraction and treatment of explosives-impacted groundwater.

	Year Cost is Incurred							NPV of Costs*	Total Costs
	1	2	3	4	5	6	7 to 30		
CAPITAL COSTS									
System Design	102,943	-	-	-	-	-	-	102,943	102,943
Well Installation	87,359	-	-	-	-	-	-	87,359	87,359
System Installation	332,152	-	-	-	-	-	-	332,152	332,152
Start-up and Testing	28,403	-	-	-	-	-	-	28,403	28,403
SUBCOST (\$)	550,857	-	-	-	-	-	-	550,857	550,857
OPERATION AND MAINTENANCE COSTS									
System Operation and Maintenance	60,386	88,788	88,788	88,788	88,788	88,788	82,059 every year	1,927,559	2,531,700
SUBCOST (\$)	60,386	88,788	88,788	88,788	88,788	88,788		1,927,559	2,531,700
LONG TERM MONITORING COSTS									
Sampling/Analysis/Reporting (Quarterly through 5 years then Annually)	40,036	40,036	40,036	40,036	40,036	13,383	12,369 every year	433,872	534,762
SUBCOST (\$)	40,036	40,036	40,036	40,036	40,036	13,383		433,872	534,762
TOTAL COST (\$)	651,279	128,824	128,824	128,824	128,824	102,172		2,912,288	3,617,319

Notes:

NPV - Net Present Value

* - NPV calculated based on a 2% discount rate

Table 8.8. Summary of capital costs and NPV of costs for O&M and monitoring for treatment of explosives-impacted groundwater.

Alternative	Capital Costs	NPV of 30 Years of O&M Costs	NPV of 30 Years of Monitoring Costs	NPV of 30 Years of Total Remedy Costs	Total 30-Year Remedy Costs
Semi-Passive Biobarrier (EVO)	\$500	\$1,060	\$430	\$1,990	\$2,430
Passive Injection Biobarrier (EVO)	\$350	\$1,280	\$430	\$2,060	\$2,580
Passive Trench Mulch Biowall (EVO)	\$390	\$1,040	\$430	\$1,860	\$2,350
Passive Trench ZVI PRB	\$1,010	\$640	\$430	\$2,080	\$2,390
Active Pump and Treat	\$550	\$1,930	\$430	\$2,910	\$3,620

notes: All costs are in thousands of dollars

NPV - Net Present Value; current value of future costs based on a 2% annual discount rate

O&M - Operation and Maintenance

9.0. IMPLEMENTATION ISSUES

9.1 END-USER IMPLEMENTATION ISSUES

The primary end-users of this technology are expected to be DoD site managers and their contractors, consultants and engineers. The general concerns of these end users are likely to include the following: (1) technology applicability and performance under local site conditions; (2) technology scale-up; (3) secondary impacts to the local aquifer; and (4) technology cost compared to other remedial options. These implementation issues are addressed in the following sections.

9.1.1 Technology Applicability and Performance

The technology utilized during this demonstration was the injection of emulsified oil substrate and buffer via a series of injection wells to form a passive biobarrier. The development of passive approaches for groundwater treatment has evolved in large part from operational issues and high costs associated with full-time active pumping systems for in situ treatment. Moreover, there are areas like an active range, where the installation of pump-and-treat infrastructure or infrastructure to operate an active or semi-passive in situ groundwater treatment system is not practical due to ongoing activities. There are several different documents that summarize the applicability of in situ emulsified oil biobarriers and provide guidance concerning their specific application (Borden, 2007; Borden *et al.*, 2008a; Borden *et al.*, 2008b; Borden and Lieberman, 2009; Weispenning and Borden, 2008). The reader is referred to these documents for further guidance on emulsified oil application for in situ contaminant treatment.

Emulsified oil can be applied in many different configurations from source area treatment systems to cut-off barriers, like that demonstrated for this field study. The primary advantages of using a passive emulsified oil biobarrier for treatment of comingled explosives and perchlorate are as follows: (1) no permanent equipment required; (2) rapid development of anaerobic conditions suitable for reduction of both perchlorate and nitramine explosives; (3) general ubiquity of organisms capable of coupling oxidation of emulsified oil (or fatty acids produced by emulsified oils) and the reduction of RDX, HMX, and perchlorate; and (4) potentially long-lived treatment with relatively low operation and maintenance costs.

Some of the limitations of this approach include (1) cost and/or technological barriers at increased depth (beyond that easily obtained by a direct-push rig); (2) difficulty injecting emulsified oils in low permeability formations; and (3) secondary groundwater impacts. Aquifer depth is one of the limiting factors for all fully passive designs, which become increasingly expensive due to close spacing of injection points and/or technically impractical (e.g., for passive trench barriers) as the depth to the water table increases (Stroo and Ward, 2008). In addition, emulsified oils are most effectively injected in aquifers where the hydraulic conductivity exceeds 4×10^{-3} cm/sec (~ 10 ft/day), and become impractical below $\sim 1 \times 10^{-4}$ cm/sec (~ 0.3 ft/day) (Borden and Lieberman, 2009). As noted in the section 9.1.2, the hydraulic conductivity at the test plot location at NSWC, Dahlgren was toward the lower end of that recommended for emulsified oil injection.

One of the typical benefits of active in situ treatment (e.g., continuous injection of lactate) is a reduction in secondary groundwater impacts that are typical of passive approaches, such as mobilization of dissolved Fe, Mn, and As, and production and accumulation of methane gas. In a typical application of emulsified oil, Fe and Mn will be mobilized within the treatment zone to mg/L concentrations, but these metals will generally be oxidized and precipitated to background levels within a several meters downgradient of the injection wells (Hatzinger and Lippincott, 2009; Krug and Cox, 2009). Similar results are expected for methane which is usually oxidized in an aerobic aquifer via methane-oxidizing bacteria.

During this demonstration, reasonably high concentrations of Fe were observed in some of the monitoring wells after emulsified oil and buffer injection. For example, Fe was detected at 22 mg/L in MW-1 after the first injection with 4% (v:v) EOS 550LS and as high as 147 mg/L after the second injection with 9% (v:v) EOS 550LS. The higher dissolved Fe after the second injection compared to the first likely reflects the higher oil concentration applied. After the first injection, dissolved Fe never exceeded 1 mg/L in MW-6, which was 40 ft downgradient of the biobarrier, showing that the Fe re-precipitated fairly quickly as expected. Similarly, after the second injection, Fe declined to 44 mg/L at MW-6, where a DO value of 3 mg/L was detected during this sampling event. Increases in As and Mn were not as high as observed for Fe, with As reaching a maximum of 40 µg/L after the first injection, and quickly declining over time. As reached a maximum of 90 µg/L after the second higher-dose injection, but monitoring did not occur long enough to quantify As re-precipitation over time. Similarly, Mn did not exceed 350 µg/L in groundwater after first oil injection, and did not exceed 700 µg/L after the second injection. It is anticipated that Fe, Mn, and As will all re-oxidize and precipitate as groundwater becomes increasingly aerobic further downgradient of the biobarrier.

This approach proved to be very effective for remediation of explosives and perchlorate over the 30-month study, and no significant operational issues were experienced. A trade-off for this approach was the production/mobilization of some secondary groundwater contaminants, such as Fe, Mn, As and methane, as previously discussed. Because there were no drinking wells in the local area and no close downgradient receptors, these contaminants were not deemed to be an important issue. However, mobilization of such contaminants should be considered in cases where downgradient receptors are present if the receptors are close in proximity to the biobarrier.

Another implementation issue is the potential formation and accumulation of the RDX nitroso-degradation intermediates, MNX, DNX and/or TNX during anaerobic treatment. During this study, we observed only transient accumulation of these products, and only at a small molar fraction of the RDX biodegraded, so clearly the ring structure of the RDX was broken during biodegradation (Cho *et al.*, 2015). Laboratory studies conducted during the course of this project indicated that degradation of RDX under sulfate-reducing or methanogenic conditions resulted in lower formation of nitroso-intermediates than under Fe- or Mn-reducing conditions, which occur at a higher ORP. Thus, addition of emulsified oils, which tend to drive aquifers to sulfate-reducing/methanogenic conditions should reduce the persistence of these intermediates.

9.1.2 Specific Implementation Issues at the Dahlgren NSWC Site

There were a few implementation issues encountered during this field demonstration at NSWC Dahlgren that should be taken into consideration when evaluating this technology for deployment at other sites, as well as some overall considerations for passive biobarriers.

- **Plume Delineation:** The contaminant plumes at NSWC Dahlgren were not sufficiently delineated prior to this demonstration due to the limited number of monitoring wells and minimal historical data. Finalizing the location, orientation, and overall width of the biobarrier for this demonstration required the installation of thirty (30) additional temporary wells and additional groundwater collection and analysis. Adequate plume delineation should be a top priority if this technology is deployed at full-scale in order to assure that the plume is fully intercepted and that treatment goals are met.
- **Site Geology:** The local geology at NSWC Dahlgren, including seams of conducting silts and sands mixed heterogeneously (horizontally and vertically) with heavy clays also had to be considered when emplacing injection and monitoring wells. The biobarrier injection wells were closely spaced (~ 5 ft between) and the rate of injection of emulsified oil into the wells was intentionally limited to <0.3 gals/min to avoid daylighting or compromising the seals on the injection wells. The hydraulic conductivity in this area of the Dahlgren site was determined to be ~ 4.4 ft/day (1.6×10^{-3} cm/sec), which is on the lower end of that deemed suitable for emulsified oil injection. A thorough understanding of local geology and groundwater hydrology needs to be achieved to allow proper placement of injection points and assure good distribution of the emulsified oil substrate.
- **Range Type:** NSWC Dahlgren is an active testing range where explosives are regularly detonated, but live fire activities (e.g., mortar, rocket, grenade training) are not common. This allowed us to place flush-mounted injection and monitoring wells far enough from the main detonation areas to avoid any damage to the demonstration plot. The generation and occurrence of UXO was also much lower at NSWC Dahlgren than would be expected at a live fire training range. Finally, the range was usually accessible for at least three consecutive days every few months due to scheduled down time or regulatory sampling events.

This technology is amenable for use at a variety of testing and training ranges. Consideration should be given to emplacing the barrier in an area that is not likely to be impacted either directly by detonations, nor by UXO. While not feasible at all sites, emplacement of permanent, flush-mounted injection wells should be preferred over using Geoprobe injection methods, both in terms of ease of follow-on injections to maintain barrier effectiveness, but also in terms of limiting UXO clearance activities to only that needed for injection well installation. At more aggressive ranges, hardened injection well vaults may be required to protect the infrastructure.

9.1.3 Technology Scale-up.

Emulsified oils have been widely used for other applications (see references previously cited in section 9.1.1), such as treatment of chlorinated solvents, so scale-up for an application with explosives and perchlorate should not be problematic. In the case at Dahlgren, the biobarrier could

have easily been scaled from 100 ft to 300 ft or so, which would have been a full scale allocation for one of the two identified plumes. Due to the relatively low hydraulic conductivity of the groundwater aquifer at NSWC Dahlgren site, another way to implement this approach full-scale would be through the installation of a sand/gravel trench barrier cross-gradient to groundwater flow, with lines for the addition of emulsified oil. This trench system would replace the closely spaced biobarrier injection wells, and could be quickly rejuvenated with additional emulsified oil on an annual or semi-annual basis as necessary.

9.1.4 Technology Cost Compared to Other Remedial Options

The expected cost drivers for the installation and operation of a passive in situ bioremediation system for explosives and comparisons to other remedial approaches are provided in Section 8.

10.0. REFERENCES

1. Albano, J., S. D. Comfort, V. Zlotnik, T. Halihan, M. Burbach, C. Chokejaroenrat, S. Onanong, and W. Clayton. 2010. *In situ chemical oxidation of RDX-contaminated groundwater with permanganate at the Nebraska Ordnance Plant*. Ground Water Monitoring & Remediation 30:96-106.
2. Andeer, P., D. A. Stahl, L. Lillis, and S. E. Strand. 2013. *Identification of microbial populations assimilating nitrogen from RDX in munitions contaminated military training range soils by high sensitivity stable isotope probing*. Environ Sci Technol 47:10356-10363.
3. Arnett, C. M., and N. R. Adrian. 2009. *Cosubstrate independent mineralization of hexahydro-1,3,5-trinitro-1,3,5-triazine (RDX) by a Desulfovibrio species under anaerobic conditions*. Biodegradation 20:15-26.
4. Arnett, C. M., G. Rodriguez, and S. W. Maloney. 2009. *Analysis of bacterial community diversity in anaerobic fluidized bed bioreactors treating 2,4-dinitroanisole (DNAN) and n-mMethyl-4-nitroaniline (MNA) uUsing 16S rRNA gene clone libraries*. Microbes Environments 24:72-75.
5. Bell, C. F. 1996. *Hydrogeology and Water Quality of the Shallow Aquifer System at the Explosive Experimental Area, Naval Surface Warfare Center, Dahlgren Site, Dahlgren, Virginia*. U.S. Geological Survey. Report# Water-Resources Investigation Report 96-4209.
6. Bhushan, B., A. Halasz, S. Thiboutot, G. Ampleman, and J. Hawari. 2004. *Chemotaxis-mediated biodegradation of cyclic nitramine explosives RDX, HMX, and CL-20 by Clostridium sp. EDB2*. Biochem Biophys Res Commun 316:816-821.
7. Blehert, D. S., B. G. Fox, and G. H. Chambliss. 1999. *Cloning and sequence analysis of two Pseudomonas flavoprotein xenobiotic reductases*. J Bacteriol 181:6254-6263.
8. Boopathy, R., M. Gurgas, J. Ullian, and J. F. Manning. 1998. *Metabolism of explosive compounds by sulfate-reducing bacteria*. Curr Microbiol 37:127-131.
9. Boparai, H. K., S. D. Comfort, T. Satapanajaru, J. E. Szecsody, P. R. Grossl, and P. J. Shea. 2010. *Abiotic transformation of high explosives by freshly precipitated iron minerals in aqueous FeII solutions*. Chemosphere 79:865-872.
10. Borden, R. C. 2007. *Concurrent bioremediation of perchlorate and 1,1,1-trichloroethane in an emulsified oil barrier*. Journal of Contaminant Hydrology 94:13-33.
11. Borden, R. C., M. Clayton, A. M. Weispenning, T. Simpkin, and M. T. Lieberman. 2008a. *Development of a Design Tool for Planning Aqueous Phase Injection Systems*.

Users Guide. ESTCP.

<http://www.estcp.org/viewfile.cfm?Doc=ER%2D0626%2DUser%2DManual%2Epdf>

12. Borden, R. C., M. Clayton, A. M. Weispenning, T. Simpkin, and M. T. Lieberman. 2008b. Emulsion Design Tool. ESTCP. http://www.estcp.org/cs_upload/ER-0626-Toolkit/
13. Borden, R. C., and M. T. Lieberman. 2009. *Passive bioremediation of perchlorate using emulsified edible oils*. p. 155-175. In H. F. Stroo and C. H. Ward (ed.), *In Situ Bioremediation of Perchlorate in Groundwater*, Springer New York, New York, NY.
14. Borden, R. C., C. E. Zawtocky, and M. T. Lieberman. 2002. *Edible Oil Barriers for Treatment of Perchlorate Contaminated Groundwater*. Environmental Security Technology Certification Program (ESTCP). Report# ER-0221.
15. Bouwer, H. 1989. *The Bouwer and Rice slug test-An update*. *Groundwater* 27:304-309.
16. Bouwer, H., and R. C. Rice. 1976. *A slug test for determining hydraulic conductivity of unconfined aquifers with completely or partially penetrating wells*. *Water Resources Research* 12:423-428.
17. Cho, K.-C., D. G. Lee, M. E. Fuller, P. B. Hatzinger, and K.-H. Chu. 2015. *Application of ¹³C and ¹⁵N stable isotope probing to characterize RDX degrading microbial communities under different electron-accepting conditions*. *J Hazard Mater* 297:42-51.
18. Cho, K.-C., D. G. Lee, H. K. Roh, M. E. Fuller, P. B. Hatzinger, and K.-H. Chu. 2013. *Application of ¹³C-stable isotope probing to identify RDX-degrading microorganisms in groundwater*. *Environ Pollut* 178:350-360.
19. Cho, Y.-S., B.-U. Lee, and K.-H. Oh. 2008. *Simultaneous degradation of nitroaromatic compounds TNT, RDX, atrazine, and simazine by Pseudomonas putida HK-6 in bench-scale bioreactors*. *Journal of Chemical Technology & Biotechnology* 83:1211-1217.
20. Coleman, N. V., D. R. Nelson, and T. Duxbury. 1998. *Aerobic biodegradation of hexahydro-1,3,5-trinitro-1,3,5-triazine (RDX) as a nitrogen source by a Rhodococcus sp., strain DN22*. *Soil Biol Biochem* 30:1159-1167.
21. Comfort, S. D., P. J. Shea, T. A. Machacek, and T. Satapanajaru. 2003. *Pilot-scale treatment of RDX-contaminated soil with zerovalent iron*. *Journal of Environmental Quality* 32:1717-1725.
22. Cozzarelli, I. M., J. S. Herman, M. J. Baedeker, and J. M. Fischer. 1999. *Geochemical heterogeneity of a gasoline-contaminated aquifer*. *Journal of Contaminant Hydrology* 40:261-284.

23. Crocker, F. H., K. J. Indest, and H. L. Fredrickson. 2006. *Biodegradation of the cyclic nitramine explosives RDX, HMX, and CL-20*. Appl Microbiol Biotechnol 73:274-290.
24. Cupples, A. M. 2013. *RDX degrading microbial communities and the prediction of microorganisms responsible for RDX bioremediation*. Int Biodeterior Biodegrad 85:260-270.
25. DeRito, C. M., G. M. Pumphrey, and E. L. Madsen. 2005. *Use of field-based stable isotope probing to identify adapted populations and track carbon flow through a phenol-degrading soil microbial community*. Applied and Environmental Microbiology 71:7858-7865.
26. Eaton, H., J. Durringer, L. Murty, and A. Craig. 2013. *Anaerobic bioremediation of RDX by ovine whole rumen fluid and pure culture isolates*. Appl Microbiol Biotechnol 97:3699-3710.
27. ESTCP. 2006. Project ER-0221 Final Report: Edible Oil Barriers for Treatment of Perchlorate-Contaminated Groundwater. <http://www.estcp.org/Technology/upload/ER-0221-FR-01-2.pdf>
28. Farhan, Y. H., and P. B. Hatzinger. 2009. *Modeling the biodegradation kinetics of perchlorate in the presence of oxygen and nitrate as competing electron acceptors*. Bioremediat J 13:65-78.
29. Federal Remediation Technologies Roundtable. 1998. *Guide to Documenting Cost and Performance for Remediation Projects*. EPA 542-B-98-007. Washington, D.C. <http://www.epa.gov/tio/download/frtr/costperf98.pdf>.
30. Fetter, C. W. 1988. *Applied Hydrology*. Second Edition. Macmillan Publishing, New York.
31. Fournier, D., A. Halasz, J. Spain, P. Fiurasek, and J. Hawari. 2002. *Determination of key metabolites during biodegradation of hexahydro-1,3,5-trinitro-1,3,5-triazine with Rhodococcus sp. strain DN22*. Appl Environ Microbiol 68:166-172.
32. Freedman, D. L., and K. W. Sutherland. 1998. *Biodegradation of hexahydro-1,3,5-trinitro-1,3,5-triazine (RDX) under nitrate-reducing conditions*. Water Sci Technol 38:33-40.
33. Fuller, M. E., P. B. Hatzinger, C. W. Condee, and A. P. Togna. 2007. *Combined treatment of perchlorate and RDX in ground water using a fluidized bed reactor*. Ground Water Monitoring & Remediation 27:59-64.
34. Fuller, M. E., J. Hawari, and N. Perreault. 2010. *Microaerophilic degradation of hexahydro-1,3,5-trinitro-1,3,5-triazine (RDX) by three Rhodococcus strains*. Lett Appl Microbiol 51:313-318.

35. Fuller, M. E., J. Kruczek, R. L. Schuster, P. L. Sheehan, and P. M. Ariento. 2003. *Bioslurry treatment for soils contaminated with very high concentrations of 2,4,6-trinitrophenylmethylnitramine (tetryl)*. *Journal of Hazardous Materials B* 100:245-257.
36. Fuller, M. E., K. McClay, J. Hawari, L. Paquet, T. E. Malone, B. G. Fox, and R. J. Steffan. 2009. *Transformation of RDX and other energetic compounds by xenobiotic reductases XenA and XenB*. *Appl Microbiol Biotechnol* 84:535-544.
37. Geosyntech. 2002. *In Situ Bioremediation of Perchlorate-Impacted Groundwater*. Environmental Security Technology Certification Program (ESTCP). Report# ER-1164.
38. Gregory, K. B., P. Larese-Casanova, G. F. Parkin, and M. M. Scherer. 2004. *Abiotic transformation of hexahydro-1,3,5-trinitro-1,3,5-triazine by Fe^{II} bound to magnetite*. *Environ Sci Technol* 38:1408-1414.
39. Griest, W. H., A. J. Stewart, R. L. Tyndall, J. E. Caton, C. H. Ho, K. S. Ironside, W. M. Caldwell, and E. Tan. 1993. *Chemical and toxicological testing of composted explosives-contaminated soil*. *Environmental Toxicology and Chemistry* 12:1105-1116.
40. Gurol, M. D., and K. Kim. 2000. *Investigation of perchlorate removal in drinking water sources by chemical methods*. p. 99-107. In E. T. Urbansky (ed.), *Perchlorate in the Environment*, Springer US, Boston, MA.
41. Halasz, A., and J. Hawari. 2011. *Degradation routes of RDX in various redox systems*. p. 441-462. In *Aquatic Redox Chemistry*, American Chemical Society,
42. Harkins, V. R., M. T., C. Heintz, and K. Rainwater. 1999. *Aerobic biodegradation of high explosives, Phase I - HMX*. *Bioremediat J* 3:285-290.
43. Hatzinger, P., and J. Diebold. 2009. *In Situ Bioremediation of Perchlorate in Groundwater*. Environmental Security Technology Certification Program (ESTCP). Report# ER-200224.
44. Hatzinger, P., and D. Lippincott. 2012. *In Situ Bioremediation of Energetic Compounds in Groundwater*. Environmental Security Technology Certification Program (ESTCP). Report# ER-200425.
45. Hatzinger, P. B. 2005. *Perchlorate Biodegradation for Water Treatment*. *Environmental Science & Technology* 39:239A-247A.
46. Hatzinger, P. B., J. Diebold, C. A. Yates, and R. J. Cramer. 2006. *Field demonstration of in situ perchlorate bioremediation in groundwater*. p. 311-341. In B. Gu. and J. C. Coates (ed.), *Perchlorate: Environment Occurrence, Interactions, and Treatment*, Spinger, New York.

47. Hatzinger, P. B., and D. L. Lippincott. 2009. *Technology Demonstration Summary Report: In situ Bioremediation of Perchlorate in Area 11 Alluvium Groundwater*. U.S. Army Corps of Engineers. Report#
48. Hawari, J., S. Beaudet, A. Halasz, S. Thiboutot, and G. Ampleman. 2000. *Microbial degradation of explosives: biotransformation versus mineralization*. Applied Microbiology and Biotechnology 54:605-618.
49. Jung, C. M., F. H. Crocker, J. O. Eberly, and K. J. Indest. 2011. *Horizontal gene transfer (HGT) as a mechanism of disseminating RDX-degrading activity among Actinomycete bacteria*. J Appl Microbiol 110:1449-1459.
50. Kim, D., and T. J. Strathmann. 2007. *Role of organically complexed iron(II) species in the reductive transformation of RDX in anoxic environments*. Environ Sci Technol 41:1257-1264.
51. Krug, T. A., and E. E. Cox. 2009. *Semi-passive in situ bioremediation*. p. 135-154. In H. Stroo and C. H. Ward (ed.), *In Situ Bioremediation of Perchlorate*, Springer, New York.
52. Krug, T. A., C. Wolfe, R. D. Norris, and C. J. Winstead. 2009. *Cost analysis of in situ perchlorate bioremediation technologies*. p. 199-218. In H. Stroo and C. H. Ward (ed.), *In Situ Bioremediation of Perchlorate*, Springer, New York.
53. Kwon, M. J., N. Wei, K. Millerick, J. Popovic, and K. Finneran. 2014. *Clostridium geopurificans strain MJ1 sp. nov., a strictly anaerobic bacterium that grows via fermentation and reduces the cyclic nitramine explosive hexahydro-1,3,5-trinitro-1,3,5-triazine (RDX)*. Curr Microbiol 1-8.
54. Lee, B.-U., M.-S. Choi, and K.-H. Oh. 2014. *Comparative analysis of explosive RDX-induced proteomes in the Pseudomonas sp. HK-6 wild-type strain and its rpoH mutant strain*. Biotechnol Bioprocess Eng 18:1224-1229.
55. Lee, S. Y., and B. W. Brodman. 2004. *Biodegradation of 1,3,5-Trinitro-1,3,5-triazine (RDX)*. Journal of Environmental Science and Health, Part A: Toxic/Hazardous Substances & Environmental Engineering 39:61-75.
56. Livermore, J. A., Y. O. Jin, R. W. Arnseth, M. LePuil, and T. E. Mattes. 2013. *Microbial community dynamics during acetate biostimulation of RDX-contaminated groundwater*. Environ Sci Technol 47:7672-7678.
57. Michalsen. 2015. *Bioaugmentation for Aerobic Bioremediation of RDX-Contaminated Groundwater*. Environmental Security Technology Certification Program (ESTCP). Report# ER-201207.

58. Michalsen, M. M., R. Weiss, A. King, D. Gent, V. F. Medina, and J. D. Istok. 2013. *Push-pull tests for estimating RDX and TNT degradation rates in groundwater*. *Groundwater Monitoring & Remediation* 33:61-68.
59. Newell, C. 2008. *Treatment of RDX & HMX Plumes Using Mulch Biowalls*. Environmental Security Technology Certification Program (ESTCP). Report# ER-0426.
60. Office of Management and Budget. 2012. *Discount Rates for Cost Effectiveness, Lease, Purchase, and Related Analysis*. http://www.whitehouse.gov/omb/circulars/a094/a94_appx-c.
61. Oh, S. K., P. C. Chiu, and D. K. Cha. 2008. *Reductive transformation of 2,4,6-trinitrotoluene, hexahydro-1,3,5-trinitro-1,3,5-triazine, and nitroglycerin by pyrite and magnetite*. *J Hazard Mater* 58:652-655.
62. Parette, R., F. S. Cannon, and K. Weeks. 2005. *Removing low ppb level perchlorate, RDX, and HMX from groundwater with cetyltrimethylammonium chloride (CTAC) pre-loaded activated carbon*. *Water Res* 39:4683-4692.
63. Park, H. S., I. Chatterjee, X. Dong, S.-H. Wang, C. W. Sensen, S. M. Caffrey, T. R. Jack, J. Boivin, and G. Voordouw. 2011. *Effect of sodium bisulfite injection on the microbial community composition in a brackish-water-transporting pipeline*. *Applied and Environmental Microbiology* 77:6908-6917.
64. Park, H. S., and H. S. Kim. 2000. *Identification and characterization of the nitrobenzene catabolic plasmids pNB1 and pNB2 in Pseudomonas putida HS12*. *J Bacteriol* 182:573-580.
65. Pester, M., E. Brambilla, D. Alazard, T. Rattei, T. Weinmaier, J. Han, S. Lucas, A. Lapidus, J.-F. Cheng, L. Goodwin, S. Pitluck, L. Peters, G. Ovchinnikova, H. Teshima, J. C. Detter, C. S. Han, R. Tapia, M. L. Land, L. Hauser, N. C. Kyrpides, N. N. Ivanova, I. Pagani, M. Huntmann, C.-L. Wei, K. W. Davenport, H. Daligault, P. S. G. Chain, A. Chen, K. Mavromatis, V. Markowitz, E. Szeto, N. Mikhailova, A. Pati, M. Wagner, T. Woyke, B. Ollivier, H.-P. Klenk, S. Spring, and A. Loy. 2012. *Complete genome sequences of Desulfosporosinus orientis DSM765T, Desulfosporosinus youngiae DSM17734T, Desulfosporosinus meridiei DSM13257T, and Desulfosporosinus acidiphilus DSM22704T*. *Journal of Bacteriology* 194:6300-6301.
66. Puls, R. W., and M. J. Barcelona. 1995. *Low-Flow (Minimal Drawdown) Ground-Water Sampling Procedures*. EPA. Report# EPA/540/S-95/504.
67. Radajewski, S., I. R. McDonald, and J. C. Murrell. 2003. *Stable-isotope probing of nucleic acids: a window to the function of uncultured microorganisms*. *Current Opinion in Biotechnology* 14:296-302.

68. Radajewski, S., G. Webster, D. S. Reay, S. A. Morris, P. Ineson, D. B. Nedwell, J. I. Prosser, and J. C. Murrell. 2002. *Identification of active methylotroph populations in an acidic forest soil by stable-isotope probing*. *Microbiology* 148:2331-2342.
69. Roh, H., C.-P. Yu, M. E. Fuller, and K.-H. Chu. 2009. *Identification of hexahydro-1,3,5-trinitro-1,3,5-triazine (RDX)-degrading microorganisms via ¹⁵N-stable isotope probing*. *Environmental Science and Technology* 43:2505–2511.
70. Ronen, Z., Y. Yanovich, R. Goldin, and E. Adar. 2008. *Metabolism of the explosive hexahydro-1,3,5-trinitro-1,3,5-triazine (RDX) in a contaminated vadose zone*. *Chemosphere* 73:1492-1498.
71. Schaefer, C. E., M. E. Fuller, C. W. Condee, J. M. Lowey, and P. B. Hatzinger. 2007. *Comparison of biotic and abiotic treatment approaches for co-mingled perchlorate, nitrate, and nitramine explosives in groundwater*. *Journal of Contaminant Hydrology* 89:231-250.
72. Seth-Smith, H. M. B., J. Edwards, S. J. Rosser, D. A. Rathbone, and N. C. Bruce. 2008. *The explosive-degrading cytochrome P450 system is highly conserved among strains of Rhodococcus spp.* *Appl Environ Microbiol* 74:4550-4552.
73. Son, A., J. Lee, P. C. Chiu, B. J. Kim, and D. K. Cha. 2006. *Microbial reduction of perchlorate with zero-valent iron*. *Water Research* 40:2027-2032.
74. Stroo, H. F., and C. H. Ward, (eds) 2008. *In Situ Bioremediation of Perchlorate in Groundwater*. Springer, 248 pp.
75. Thompson, K. T., F. H. Crocker, and H. L. Fredrickson. 2005. *Mineralization of the cyclic nitramine explosive hexahydro-1,3,5-trinitro-1,3,5-triazine by Gordonia and Williamsia spp.* *Appl Environ Microbiol* 71:8265-8272.
76. URS. 2007. *Spring 2007 Groundwater Monitoring Report for the Open Burn/Open Detonation Unit, Naval Surface Warfare Division Dahlgren, Dahlgren, Virginia*. URS Group Inc., Oak Ridge, TN.
77. URS. 2010. *Groundwater Flow and Transport Modeling Report, Explosives Experimental Area, Naval Surface Warfare Center Dahlgren (Draft Report)*. URS Group Inc., Oak Ridge, TN.
78. USGS. 2010. Slug Test Spreadsheet. <http://pubs.usgs.gov/of/2002/ofr02197/>
79. Van Aken, B., J. M. Yoon, and J. L. Schnoor. 2004. *Biodegradation of nitro-substituted explosives 2,4,6-trinitrotoluene, hexahydro-1,3,5-trinitro-1,3,5-triazine, and octahydro-1,3,5,7-tetranitro-1,3,5-tetrazocine by a phytosymbiotic Methylobacterium sp. associated with poplar tissues (Populus deltoides x nigra DN34)*. *Applied and Environmental Microbiology* 70:508-517.

80. Wade, R., J. L. Davis, A. H. Wani, and D. Felt. 2010. *Biologically Active Zone Enhancement (BAZE) for In Situ RDX Degradation in Ground Water*. Environmental Security Technology Certification Program (ESTCP). Report# ER-200110.
81. Wang, C., L. Lippincott, and X. Meng. 2008. *Kinetics of biological perchlorate reduction and pH effect*. Journal of Hazardous Materials 153:663-669.
82. Weeks, K. R., S. C. Veenstra, D. L. Hill, and B. P. Gregson. 2003. *A study of treatment options to remediate explosives and perchlorate in soils and groundwater at Camp Edwards, Massachusetts*. Remediation 13:131-143.
83. Weispenning, A. M., and R. C. Borden. 2008. *A design tool for planning emulsified oil-injection systems*. Remediation Journal 18:33-47.
84. Zhang, C., R. C. Daprato, S. F. Nishino, J. C. Spain, and J. B. Hughes. 2001. *Remediation of dinitrotoluene contaminated soils from former ammunition plants: soil washing efficiency and effective process monitoring in bioslurry reactors*. Journal of Hazardous Materials 87:139-154.
85. Zheng, X., Y. Su, X. Li, N. Xiao, D. Wang, and Y. Chen. 2013. *Pyrosequencing reveals the key microorganisms involved in sludge alkaline fermentation for efficient short-chain fatty acids production*. Environmental Science & Technology 47:4262-4268.