



**US Army Corps
of Engineers®**
Engineer Research and
Development Center

Dredging Operations and Environmental Research Program

Mass Balance, Beneficial Use Products, and Cost Comparisons of Four Sediment Treatment Technologies Near Commercialization

Trudy J. Estes, Victor S. Magar, Daniel E. Averett,
Nestor D. Soler, Tommy E. Myers, Eric J. Glisch and
Damarys A. Acevedo

March 2011



Mass Balance, Beneficial Use Products, and Cost Comparisons of Four Sediment Treatment Technologies Near Commercialization

Trudy J. Estes, Daniel E. Averett, Tommy E. Myers, and Damarys A. Acevedo

*Environmental Laboratory
U.S. Army Engineer Research and Development Center
3909 Halls Ferry Road
Vicksburg, MS 39180-6199*

Eric J. Glisch

*U.S. Army Engineer District, New Orleans
7400 Leake Avenue
New Orleans, LA 70118*

Victor S. Magar and Nestor D. Soler

*ENVIRON International Corporation
333 West Wacker Drive, Suite 2700
Chicago, IL 60606-2872*

Final report

Approved for public release; distribution is unlimited.

Abstract: The concept of contaminated sediment treatment producing a useful product has emerged in recent years, motivated by the cost of sediment disposal and by recognition of sediment as a resource rather than a waste. Contaminated sediment presents unique challenges for treatment, however, due to the character and complexity of the matrix, and the logistics and economics involved in coupling the process with a dredging operation. The objectives of this document are to capture the technical status of several promising treatment technologies of this type, to describe the process efficiency in terms of mass balance, to understand pre-treatment and post-treatment processing requirements, and to estimate full scale implementation costs at a scale compatible with a dredging operation. Overall, the document overlays a consistent and transparent structure on the comparative evaluation with the objective of providing an equivalent basis for comparison between these and other candidate treatment processes, such that it has utility of remediation to project managers and others engaged in technology selection efforts. Relying on publicly available demonstration reports, the following technologies were evaluated in depth: JCI/Upcycle rotary kiln thermal treatment/light-weight aggregate (LWA); Cement-Lock[®] technology/cement; Minergy[®] glass furnace technology/glass aggregate; and BioGenesisSM sediment washing process/manufactured soil.

DISCLAIMER: The contents of this report are not to be used for advertising, publication, or promotional purposes. Citation of trade names does not constitute an official endorsement or approval of the use of such commercial products. All product names and trademarks cited are the property of their respective owners. The findings of this report are not to be construed as an official Department of the Army position unless so designated by other authorized documents.

DESTROY THIS REPORT WHEN NO LONGER NEEDED. DO NOT RETURN IT TO THE ORIGINATOR.

Contents

Figures and Tables	vii
Preface	x
Unit Conversion Factors	xii
Summary	xiii
1 Introduction	1
Background	1
<i>What is the issue?</i>	1
<i>Purpose and relevance to the remediation project manager</i>	2
<i>What's in this report?</i>	2
Major technology development programs	3
Overview of technology types	4
General considerations for technology selection	5
<i>Pretreatment requirements</i>	5
<i>Decontamination or treatment efficiency</i>	5
<i>Residuals treatment requirements</i>	6
<i>Mass balance—challenges and limitations</i>	6
<i>Environmental dredging compared to navigation dredging</i>	9
<i>Capacity and scale up</i>	9
<i>Economics</i>	10
<i>Safety and public acceptability</i>	11
<i>Approval and permitting requirements</i>	12
Technology evaluation measures	12
2 Technology Briefs	15
General information	15
JCI/Ucycle Rotary Kiln brief	17
<i>Synopsis</i>	17
<i>Applicability</i>	17
<i>Engineering considerations</i>	17
<i>Developmental status</i>	19
<i>Performance</i>	20
<i>Residuals and byproducts</i>	25
<i>Beneficial use end product</i>	25
<i>Cost</i>	25
<i>Technology references/reports</i>	28
<i>Technology points of contact</i>	28
Cement-Lock® brief	29
<i>Synopsis</i>	29
<i>Applicability</i>	29

<i>Engineering considerations</i>	30
<i>Developmental status</i>	31
<i>Performance</i>	32
<i>Residuals and byproducts</i>	38
<i>Cost</i>	40
<i>Technology references/reports</i>	41
<i>Technology points of contact</i>	41
Minergy glass furnace technology (GFT) brief	42
<i>Synopsis</i>	42
<i>Applicability</i>	42
<i>Engineering considerations</i>	43
<i>Developmental status</i>	46
<i>Performance</i>	46
<i>Residuals and byproducts</i>	51
<i>Beneficial use end product</i>	53
<i>Cost</i>	53
<i>Technology references/reports</i>	53
<i>Technology points of contact</i>	54
BioGenesis SM Sediment Washing Technology brief	54
<i>Synopsis</i>	54
<i>Applicability</i>	55
<i>Engineering considerations</i>	55
<i>Developmental status</i>	58
<i>Performance</i>	60
<i>Residuals and byproducts</i>	67
<i>Beneficial use end product</i>	69
<i>Cost</i>	69
<i>Technology point of contact</i>	71
3 Mass Balance Evaluations	72
JCI/Upcycle Rotary Kiln mass balance	72
<i>Operational description</i>	72
<i>Mass balance</i>	76
<i>Technical issues</i>	81
<i>JCI/Upcycle rotary kiln capacity</i>	83
<i>JCI/Upcycle rotary kiln residuals</i>	83
<i>Beneficial use product</i>	84
Cement-Lock [®] mass balance	86
<i>Operational description</i>	86
<i>Mass balance</i>	87
<i>Technical issues</i>	93
<i>Cement-Lock[®] capacity</i>	94
<i>Cement-Lock[®] residuals</i>	94
<i>Beneficial use product</i>	95
Minergy glass furnace technology mass balance	96
<i>Operational description</i>	96

<i>Mass balance</i>	97
<i>Technical issues</i>	103
<i>Minergy GFT capacity</i>	108
<i>Minergy GFT residuals</i>	108
<i>Beneficial use product</i>	109
BioGenesis SM Sediment Washing Technology mass balance	109
<i>Operational description</i>	109
<i>Mass balance</i>	112
<i>Technical issues</i>	129
<i>BioGenesisSM capacity</i>	131
<i>BioGenesisSM residuals</i>	131
<i>Beneficial use product</i>	132
4 Cost Evaluation	133
Scope	133
<i>General</i>	133
<i>Contents of the chapter</i>	134
Baseline cost items	136
<i>Capital costs</i>	136
<i>Operating costs</i>	138
Evaluation of costs provided by the technology developers	140
<i>General considerations</i>	140
<i>Rotary kiln technology - reported costs</i>	141
<i>Cement-Lock[®] technology - reported costs</i>	142
<i>Minergy glass furnace technology - reported costs</i>	144
<i>BioGenesisSM sediment washing - reported costs</i>	144
<i>Data gaps and adjusted costs</i>	147
<i>Summary</i>	151
Cost sensitivity	151
Use of the normalized cost estimates	152
5 Commercialization Potential	153
JCI/Upcycle Rotary Kiln	153
Cement-Lock [®]	154
Minergy	154
Biogenesis SM	155
Obstacles to commercialization	155
6 Comparative Process Summary	157
7 Conclusions	165
Maximum scale of demonstrations to date:	165
Processing Issues	165
Treatment Efficiency/Effectiveness	166
Cost	167
Looking forward	168

References	170
Appendix A: Major Technology Development Programs.....	175
Appendix B: JCI/Ucycle Rotary Kiln Mass Balance.....	180
Appendix C: Cement-Lock® Mass Balance.....	197
Appendix D: Minergy Mass Balance	206
Appendix E: BiogenesisSM WRDA NYNJ Harbor Demonstration Mass Balance.....	215
Appendix F: BioGenesisSM VENICE DEMONSTRATION MASS BALANCE MASS BALANCE	225
Report Documentation Page	

Figures and Tables

Figures

Figure 1. Process efficiency accounting for a rotary kiln process (Continued)	7
Figure 2. Rotary kiln (from NJDOT project update sheet)	17
Figure 3. JCI/Upcycle rotary conceptual kiln pre-treatment flow diagram.	18
Figure 4. JCI/Upcycle rotary kiln process flow diagram.	19
Figure 5. Cement-Lock® demo plant (Mensingher 2008a)	29
Figure 6. Diagram for Process flow diagram for cement-Lock® treatment.	30
Figure 7. Pilot-scale glass furnace (USEPA 2004).....	42
Figure 8. Pretreatment processes for glass furnace technology.....	44
Figure 9. Process flow diagram for minergy glass furnace technology.....	45
Figure 10. Biogenesis SM commercial scale, Keasby, NJ (Stern et al. 2009)	54
Figure 11. Process flow diagram for BioGenesis SM sediment washing-NYNJH Project.	56
Figure 12. Process flow diagram for BioGenesis SM sediment washing-Venice Project.	57
Figure 13. Process flow diagram for Biogenesis® 2006 demonstration-Keasby, NJ (Biogenesis Washing BGW, et al. 2009).	59
Figure 14. Rotary kiln materials mass balance based on 100 units dry sediment solids treated.	77
Figure 15. Fate of arsenic in rotary kiln (total mass basis).	79
Figure 16. Fate of mercury in rotary kiln (total mass basis).	80
Figure 17. Fate of benzo(a)pyrene in rotary kiln.	80
Figure 19. Cement-Lock® materials mass balance based on 100 mass units dry sediment solids treated.	89
Figure 20. Fate of arsenic mass in Cement-Lock® process.	89
Figure 21. Fate of lead mass in Cement-Lock® process.....	90
Figure 22. Fate of mercury mass in Cement-Lock® process.....	90
Figure 23. Fate of total PCB mass in Cement-Lock® process.....	91
Figure 24. Fate of total PAH mass in Cement-Lock® process.	91
Figure 26. Fate of arsenic mass in Minergy GFT process.....	104
Figure 27. Fate of barium mass in Minergy GFT process.....	104
Figure 28. Fate of chromium mass in Minergy GFT process.....	105
Figure 29. Fate of mercury mass in Minergy GFT process.	105
Figure 30. Fate of total PCB mass in Minergy GFT process.	106
Figure 31. BioGenesis SM materials balance for NYNJ pilot demonstration.....	114
Figure 32. Materials mass balance for Venice sediments (Numbers 1-4 indicate 4 batches, each from a different site).	115
Figure 33. Fate of total copper in BioGenesis SM process for NYNY Harbor (1999 pilot).....	119
Figure 34. Fate of total mercury in BioGenesis SM process for NYNY Harbor (1999 pilot).....	120

Figure 35. Fate of fluoranthene in BioGenesis SM process for NYNY Harbor (1999 pilot).	121
Figure 36. Fate of total PAHs in BioGenesis SM process for NYNY Harbor (1999 pilot).	121
Figure 37. Fate of total arsenic in BioGenesis SM process for Venice sediments.....	123
Figure 38. Fate of total lead in BioGenesis SM process for Venice sediments.	123
Figure 39. Fate of total mercury in BioGenesis SM process for Venice sediments.	124
Figure 40. Total metals fate for four Venice sediments.	124
Figure 41. Fate of total PAHs in BioGenesis SM process for Venice sediments.	125
Figure 42. Grain size distribution in feed and product streams for four Venice sediments	126
Figure 43. Fate of total hydrocarbons in BioGenesis SM process for Venice sediments.....	127
Figure 44. Solids mass balance – thermal technologies.	160

Tables

Table S1. Treatment technology characteristics and scale	xv
Table S2. Summary of decontamination and overall treatment efficiencies calculated on a total contaminant mass balance basis.....	xvii
Table S3. Adjusted cost estimates ¹	xxii
Table 1. Comparisons of treatment mechanisms beneficial use products and area requirements for selected processes.....	15
Table 2. Comparisons of operational characteristics for selected processes	16
Table 3. Rotary kiln process stages.	18
Table 4. Percent contaminant mass extractable by TCLP.....	24
Table 5. JCI/Ucycle process residuals—character and relative magnitude.	26
Table 6. Cement-Lock [®] process stages	30
Table 7. Average Ecomelt [®] generator stage efficiencies for contaminants of concern during extended duration tests with Passaic River sediments.....	36
Table 8. Decontamination efficiencies for contaminants of concern during extended duration tests with Passaic River sediments.	37
Table 9. Cement-Lock [®] process residuals—character and relative magnitude.....	39
Table 10. Minergy glass furnace technology process stages.....	44
Table 11. Glass Furnace Technology process residuals—character and relative magnitude.	52
Table 12. BioGenesis SM process stages.....	56
Table 13. Mass balance efficiencies for BioGenesis SM NYNJH pilot study.....	63
Table 14. Mass balance efficiencies for BioGenesis SM Venice pilot demonstration.....	64
Table 15. Stage efficiencies for BioGenesis SM unit processes during NYNJH pilot study.	65
Table 16. BioGenesis SM process residuals—character and relative magnitude	68
Table 17. Sampling and testing matrix for Rotary Kiln treatment stages and process streams ⁶	73
Table 18. Sampling and testing matrix for Cement-Lock [®] treatment stages and process streams.....	88
Table 19. Average activated carbon capture efficiencies for contaminants of concern during extended duration tests with Passaic River sediments.....	95

Table 20. Results of compression strength tests comparing Ecomelt® blended concrete (40%) to neat Portland cement concrete ¹ .	96
Table 21. Sampling and testing matrix for Minergy GFT treatment stages and process streams.	99
Table 22. Minergy Corporation glass aggregate marketing chemical and physical property analysis.	110
Table 23. Sampling and testing matrix for Biogenesis Venice demonstration treatment stages and process streams.	113
Table 24. Sampling and testing matrix for Biogenesis NYNJH Pilot (part 1 of 3).	116
Table 25. Sampling and testing matrix for Biogenesis NYNJH Pilot (part 2 of 3).	117
Table 26. Sampling and testing matrix for Biogenesis NYNJH Pilot (part 3 of 3).	118
Table 27. Demonstration projects used by the technology developers for scaling up cost estimates to full scale.	136
Table 28. Technology developer cost estimating basis and assumptions.	137
Table 29. Reported cost from technology developers.	140
Table 30. <u>Capital</u> cost estimate comparisons (cost line items \$/yd ³).	148
Table 31. <u>Operating</u> cost estimate comparisons (Continued).	149
Table 32. Qualitative cost sensitivity analysis.	152
Table 33. Thermal technologies - material and contaminant mass as percent of incoming material and contaminant mass in filter cake feed.	158
Table 34. Biogenesis SM - Material and contaminant mass as percent of incoming sediment feed mass – Venice demonstration mass balance.	161
Table A1. Sediment treatment research and development programs	175
Table A2. Technologies demonstrated under the ARCS Program	177
Table A3. Technologies demonstrated under the WRDA program (USEPA Region 2, USACE NY District, and BNL)	178

Preface

This report is directed at U.S. Army Corps of Engineers (USACE) and U.S. Environmental Protection Agency (USEPA) project managers having responsibility for management of contaminated sediments, as well as those in other agencies and the private sector involved with contaminated sediment management or technology development. The concept of contaminated sediment treatment producing a useful product has emerged in recent years, motivated by the cost of sediment disposal and by recognition of sediment as a resource rather than a waste. Contaminated sediment presents unique challenges for treatment, however, due to the character and complexity of the matrix, and the logistics and economics involved in coupling the process with a dredging operation. The objectives of this document are to capture the technical status of several promising treatment technologies of this type, to describe the process efficiency in terms of mass balance, to understand pre-treatment and post-treatment processing requirements, and to estimate full-scale implementation costs at a scale compatible with a dredging operation. In addition, this document attempts to identify the technical, logistical, economic, policy, and regulatory obstacles to commercialization. Overall, the document lays the foundation for more consistent and transparent technology documentation and comparison, essential to potential technology consumers.

The USEPA Technology Office of Superfund Remediation and Technology Innovation (OSRTI) Technology Assessment Branch and the USACE Dredging Operations and Environmental Research Program (DOER) funded preparation of this report. Dr. Trudy J. Estes, Daniel E. Averett, Dr. Tommy E. Myers, and Damarys A. Acevedo, Environmental Engineering Branch, Environmental Laboratory (EL), Engineer Research and Development Center (ERDC); Mr. Eric J. Glisch, U.S. Army Engineer District, New Orleans; and Dr. Victor S. Magar and Nestor D. Soler, ENVIRON International Corporation, prepared the report. Linda Fiedler and Steve Ells, USEPA OSTRI, and Kelly Madalinski, Port of Portland (formerly with USEPA), provided oversight and management for the USEPA. Dr. Todd S. Bridges, EL Senior Scientist and DOER Program Manager, provided program oversight for ERDC.

Technical review of the manuscript for ERDC was provided by Dr. Heather M. Smith, EL, and Norman R. Francingues, Jr., Consultant. Also acknowledged are constructive comments received from Michael Mensinger, Gas Technology Institute; Al Hendricks, Volcano Partners, LLC; John Sontag, Jr., Biogenesis Enterprises, Inc.; and Jay Derman, P.E.

The work was performed under the direct supervision of Deborah Felt, Chief, Environmental Engineering Branch, and Dr. Richard E. Price, Chief, Environmental Processes and Engineering Division, ERDC, and under the general supervision of Dr. Elizabeth Fleming, Director, EL, ERDC.

COL Kevin J. Wilson was ERDC Commander and Executive Director.
Dr. Jeffery P. Holland was ERDC Director.

Unit Conversion Factors

Multiply	By	To Obtain
acres	4,046.873	square meters
British thermal units (International Table)	1,055.056	joules
cubic feet	0.02831685	cubic meters
cubic yards	0.7645549	cubic meters
degrees Fahrenheit	$(F-32)/1.8$	degrees Celsius
feet	0.3048	meters
gallons (U.S. liquid)	3.785412 E-03	cubic meters
inches	0.0254	meters
microns	1.0 E-06	meters
miles (U.S. statute)	1,609.347	meters
pounds (mass)	0.45359237	kilograms
pounds (mass) per cubic foot	16.01846	kilograms per cubic meter
pounds (mass) per cubic inch	2.757990 E+04	kilograms per cubic meter
pounds (mass) per square foot	4.882428	kilograms per square meter
square feet	0.09290304	square meters
pounds (mass) per square inch	6.894757	kilopascal
square inches	6.4516 E-04	square meters
square miles	2.589998 E+06	square meters
square yards	0.8361274	square meters
tons (2,000 pounds, mass)	907.1847	kilograms
yards	0.9144	meters

Summary

Purpose

Highly contaminated sediments dredged from waterways, either for remediation purposes or to maintain navigation channels, present significant short- and long-term management challenges. Treatment of dredged material, while theoretically desirable, has proven to be difficult to implement for various reasons. In this document the performance of four technologies sufficiently developed to be near commercialization was evaluated in depth. All of the technologies evaluated here have the potential for producing a beneficial use product in conjunction with treatment of contaminated sediment. Information from multiple project demonstration reports was synthesized. Mass balances were reconstructed from available raw data to verify performance and identify contaminant removal mechanisms.

This document attempts to impose a consistent and transparent structure on the comparative evaluation, from mass balance to cost estimating, such that it has utility for technology selection efforts, taking into account process requirements and their associated impacts on logistics and economics, and considerations for full-scale implementation.

Approach

Technology briefs were prepared for each technology, highlighting the major processes and considerations. Process flow diagrams (PFD) were developed to reflect pre-treatment processes required for integration with a dredging operation and waste streams produced by the complete process. More detailed technology evaluations included:

- Materials and contaminant mass balances, reconstructed on the basis of data obtained from published reports
- Performance evaluations, based on the reconstructed mass balances
- Current year adjustment of cost estimates reported by the vendors and comparison to a uniform set of assumptions and cost factors

The technologies selected for evaluation met the following criteria:

- Applied to contaminated sediments
- Demonstrated at pilot scale or greater in a technology verification program
- Having potential for commercialization or nearing commercialization
- Treating or immobilizing contaminants (metals and organics)
- Generating a product suitable for beneficial use
- Potential for scalability and mobility

Strictly physical technologies, such as solid separation, were not included since these address only volume reduction, not contaminant destruction or immobilization. Also, the operations utilized in solidification and stabilization are commonly practiced and non-proprietary options for immobilization technology are well developed.

Three of the technologies included here are thermal technologies and one is a physical-chemical technology. The technologies and their beneficial use products were:

- Rotary kiln thermal treatment/light-weight aggregate (LWA)
- Cement-Lock® technology/cement
- Minergy® glass furnace technology/glass aggregate
- BioGenesisSM sediment washing technology/manufactured soil

Current technology configurations and scale

Features and scale for the four technologies are summarized in Table S1. These technologies have been used to treat dredged materials in demonstration projects for relatively small volumes, to date. The thermal technologies primarily decontaminate sediment with a heating unit operating at temperatures of 1400 to 1600°C (2600 to 2900°F), followed by processes to control air emissions. The sediment washing technology operates at ambient temperature, and includes several physical and chemical operations designed to separate and collect less contaminated sediment particles and to desorb contaminants from sediment particles so that metals can be transferred to the aqueous phase, and organic contaminants chemically oxidized. Table S1 shows that the maximum demonstrated processing rate for the Biogenesis process (30 m³/hr) is more than 40 times greater than the demonstrated processing rate for the thermal technologies to date.

Table S1. Treatment technology characteristics and scale

Characteristic	JCI/Ucycle Rotary Kiln	Gas Technology Institute Cement-Lock®	Minergy® Glass Furnace	Biogenesis SM Sediment Washing
Process type	Thermal	Thermal	Thermal	Physical-chemical
Treatment mechanisms – organics	Thermal decomposition, volatilization	Thermal decomposition, volatilization	Thermal decomposition, vitrification, volatilization	Phase transfer, particle separation, oxidation, filtration, carbon adsorption
Treatment mechanisms - metals	Immobilization, volatilization, incidental dilution	Immobilization, volatilization, incidental dilution	Immobilization, volatilization	Phase transfer, particle separation, chelation, filtration, carbon adsorption
Beneficial use product	Lightweight aggregate	Ecomelt® (blended cement (mixed with Portland cement), electrical power	Glass aggregate, electrical power	Base material for manufactured topsoil
Sediment (in situ volume) treated at maximum demonstrated processing rate	3.1 m ³ (4.0 yd ³)	34 m ³ (44 yd ³)	12 m ³ (16 yd ³)	11,000 m ³ (15,000 yd ³)
Maximum demonstrated processing rate (sediment – in situ volume)	0.03 m ³ /hr (0.04 yd ³ /hr)	1 m ³ /hr (1 yd ³ /hr)	0.02 m ³ /hr (0.03 yd ³ /hr)	30 m ³ /hr (40 yd ³ /hr)
Pretreatment requirements	Debris removal, dewatering, drying	Debris removal, crushing, dewatering (if hydraulically dredged), drying	Debris removal, dewatering, removal of metal objects, drying	Debris removal, screening (integral to process)
Treatment unit operations (at commercial scale)	Hammermill dryer, kiln, extruder (pellitizer), secondary combustion, baghouse, scrubber, crusher	Dryer, kiln, granulator, grinder, secondary combustion, heat recovery, generators, lime baghouses, carbon baghouses	Dryer, glass furnace, quench tank, grinder, heat exchangers, packed tower scrubber, particulate collector, carbon bed	Mixers, flotation, collision chambers, cavitation/oxidation, hydrocyclones, screens, filter presses, centrifuges, carbon columns, sand filters
System inputs	Air, fuel, water, shale, sodium hydroxide (scrubber)	Air, fuel, modifiers, water, lime (baghouse)	Fuel, oxygen, flux, lime (dewatering), water	Water, surfactants, oxidizers, chelants, polymers
Process residuals	Debris, offgases, particulates, wastewater	Debris, offgases, particulates, wastewater, spent carbon	Debris, offgases, particulates, wastewater, spent carbon	Debris, treated wastewater, fine-grained solids

Treatment efficiency

Treatment efficiency (or percent removal) and decontamination are terms often used interchangeably as a measure of the contaminant reduction achieved in the treated solids. However, a process may be highly efficient in terms of removing contaminants from the sediment without being efficient in terms of contaminant destruction. Overall process efficiency (total output vs. total input), stage efficiency (stage output vs. stage input, *or “where in the process”* the treatment is occurring), and decontamination efficiency (final sediment concentration vs. initial sediment concentration) have important distinctions. Each has different implications with respect to overall environmental impact, utility of additional treatment stages, magnitude of residuals, and contaminant levels in the final sediment product. Also important is distinguishing contaminant immobilization, contaminant destruction, and simple phase transfer of contaminants, the latter process resulting in residuals that must be managed. Process efficiencies were calculated for each process on the basis of these definitions to facilitate comparison on an equivalent basis. The capability of each technology in terms of efficiency must be weighed against the allowable residual concentrations for a particular site.

A summary of the overall efficiencies and decontamination efficiencies for each process and a representative list of contaminants are presented in Table S2. Residual contaminants in products and waste streams result in a lower overall process efficiency as compared to the decontamination efficiency, which simply considers the comparison of raw (untreated) material to the product (treated) material. Some of the process waste streams, such as bag house solids or wastewater, can potentially be recycled through the process to reduce residuals. In some cases, however, wastewater streams may require additional treatment or may be released to a public sewer system without further treatment. Contaminants in gases from the thermal processes can be controlled but not completely eliminated. Handling, treating, managing, and transporting residual streams are important cost considerations.

The thermal technologies are effective for treatment of most organics and metals at a wide range of contaminant concentrations. Treatment mechanisms include thermal destruction of organic contaminants, immobilization of metals in the crystalline solid product, and incidental volatilization to the offgas stream of both organics and metals. However, some contaminants may remain leachable at minimal levels in the

aggregate product. Limitations to the thermal technologies include high capital cost and scale of the equipment, limiting mobility and thus requiring a significant and sustained supply of raw material in the vicinity of a permanent installation for long-term operation and capital cost recovery. The technologies are also energy intensive. Sediment feed materials for thermal technologies must undergo varying levels of pre-treatment, including removal of both large and small metallic debris, dewatering, and drying to low moisture content prior to feeding to the core thermal processing unit.

Table S2. Summary of decontamination and overall treatment efficiencies calculated on a total contaminant mass balance basis

Contaminant	JCI/Ucycle Rotary Kiln		Gas Technology Institute Cement-Lock®		Minergy® Glass Furnace		Biogenesis SM Sediment Washing (1999 Demo)	
	Decon. Efficiency	Overall Efficiency	Decon. Efficiency	Overall Efficiency	Decon. Efficiency	Overall Efficiency	Decon. Efficiency	Overall Efficiency
Arsenic	44	37	54	54	100	99	61 ^a	-1 ^a
Barium	66	65	-5.7	-5.8	-270	-270		
Cadmium	100	59	94	94	100	99	76 ^a	8 ^a
Chromium	93	78	38	38	-31	-31	82 ^a	11 ^a
Lead	95	69	93	93	100	99	74 ^a	5 ^a
Mercury	98	61	>99	97	81	80	95 ^a	40 ^a
Zinc	92	78	87	87			71 ^a	22 ^a
Benzo(a)pyrene	100	85	100	>99			55	55
Anthracene	100	85	100	100			100	98
Chrysene	100	85	100	100			57	57
Fluoranthene	100	81	100	>99			70 ^a	51 ^a
Napthalene	100	75	100	100			100	100
Total PAHs	100	82	100	>99			66	61
Total PCBs	100	84	>99	>99	>99	>99	>99	54
Total Dixoins/ Furans	>99	84	>99	>99	>99	100	>99	79
DDT Metabolites	100	85	100	100			56	16
Total SVOCs					100	100		

Note that these contaminants were not specifically targeted as they were already below criteria. According to the vendor higher efficiency may be possible if process chemicals are specifically tailored to removal of these contaminants.

Physical separation as a volume reduction method is a mature technology. Contaminated fractions are removed from the sediment by selective removal of specific size or density fractions, typically the fines and humic fractions, thus leaving a “washed” coarse fraction. BioGenesisSM Sediment Washing is a proprietary technology that modifies traditional physical separation by adding unit operations designed to disaggregate sediment particles and chemically oxidize organic chemicals. The goal of the BioGenesisSM process is to achieve some treatment of the fine fraction, rather than simply separating the fines from the coarse for separate disposal.

Limitations of the BioGenesisSM sediment washing process include generation a treated wastewater stream requiring disposal or permitted discharge, and limited effectiveness (compared to thermal technologies) in terms of physical/chemical oxidation of organic contaminants. Although less pre-treatment of feed material is required for this process, highly contaminated sediments or sediments with contaminants recalcitrant to this type of treatment may require multiple passes through the system, requiring longer cycle times or additional processing units to maintain throughput, resulting in increased capital and operational costs. Treatment mechanisms include physical/chemical oxidation of organic materials and contaminants, solubilization of particulate associated contaminants and separation of more highly contaminated particulates as part of the wastewater stream. Incidental volatilization of metals and organics may also occur. Capital and energy costs for this technology are expected to be lower than the thermal technologies, however, and the technology may be more amenable to modularization to increase mobility.

The degree of contaminant reduction was lower for the sediment washing technology than for the thermal technologies, and, based on pilot studies, was attributed more to volatilization, solubilization of contaminants and separation of fine solids than to contaminant destruction through the cavitation/oxidation process. PAHs proved somewhat recalcitrant to the oxidation process. Additional bench testing was done on Passaic River sediments (Biogenesis Washing BGW, LLC and MHW Americas, Inc. 2009) to address this issue. In the most successful test, micro-flotation was added to augment removal of detritus from mineral sediment particles. The process was successful in separating a concentrated detritus fraction with PAH concentrations approximately 329 percent that of the incoming sediment. How much PAH reduction was attributable to

cavitation/oxidation, and whether further reduction with refinement of the flotation step is possible are interesting questions that remain to be addressed. Whether flotation would be successful in removing a coarse condensed carbon phase is also an unknown. Additional process modifications, such as an upflow separator, might be required as a cleaning step for such sediments. The modification has not been demonstrated on a larger scale.

Because phase transfer is the principal mechanism of removal for metals and for at least a portion of the organic contaminants in the sediment washing technology, the wastewater stream undergoes chemical/physical treatment prior to discharge under recent modifications to the process. Unless the treated wastewater can be recycled in the BiogenesisSM process, the volume is anticipated to be of a much greater magnitude than the effluent produced in conjunction with the thermal technologies. The dewatering requirement of the thermal technologies will result in a filtrate that will also require management.

Technology selection

General considerations for treatment technology selection include the following:

- Pretreatment requirements
- Decontamination or treatment efficiency
- Residuals treatment and/or disposal requirements
- Potential for beneficial use of treated sediment
- Capacity and scale up
- Economics
- Safety and public acceptability
- Approval and permitting requirements

The best technology choice for a given site will require careful evaluation of the efficiency achievable (and required) for a given suite of contaminants and bulk sediment concentrations, coupled with careful cost analysis taking into account all of the processes integral to the operation, as well as costs associated with management of the residuals. Because contaminated sediments generally contain multiple contaminants, achieving equal efficiency for all contaminants is particularly challenging. Based on the results presented in this document, PCBs, PAHs, dioxins, and other organic contaminants were effectively treated by the thermal technologies. PAHs

proved to be recalcitrant to the sediment washing technology although improved methods of separating natural organic material from the sediment were identified in subsequent bench testing (Biogenesis Washing BGW, LLC and MHW Americas, In. 2009). Combining treatment types to improve efficiency might be an effective approach where a diverse suit of contaminants is present and sequential treatment proves advantageous, although the combined cost could be prohibitive.

Cost is a significant driver for dredging of all contaminated sediment projects. Presently, treatment appears to be most applicable to those sites where environmental remediation is taking place and treatment provides a viable alternative to off-site disposal. Where significant up-front capital investment for a permanent facility is required, however, material supply cannot be episodic in nature. This requires consistent funding streams either from a large cleanup site or dredging occurring within reasonable proximity to the plant, the capability of processing a variety of readily available wastes, or a modular technology that can “follow the funding stream.” Even if the supply issues are addressed successfully, sufficient value and consistent demand for the beneficial use product also will be required.

The lack of long-term environmental and performance data may initially present an impediment to market acceptance of the treatment products. One strategy that might be employed is to incorporate use of the products as part of an overall site remediation plan. Sites at which a combination of remedies will be employed, including removal and capping, may provide the best opportunity. Decontaminated sediment produced from more contaminated sediments could be incorporated as part of the capping material for portions of the site. Long-term monitoring is normally a part of the remedy specified for such sites, and this would provide the opportunity to obtain performance data for these products in a beneficial use application. Some analytical cost savings could be realized in this manner, raw materials required for capping reduced, and off-site disposal costs eliminated. This could ultimately provide a stepping stone to a niche for these technologies.

Cost

While all of the technologies demonstrated under the validation programs were required to provide cost estimates for operation at full scale, a standardized template or format for determining estimated costs was not

provided. Baseline assumptions differed considerably from one technology to another. As a consequence, direct comparisons of the cost estimates provided for the different technologies were difficult. In most cases, vendor cost estimates for a full-scale operation were based on an annual volume of 380,000 m³ (500,000 yd³) (as specified by New York and New Jersey sponsors) and continuous operation of the processing plant over a period of 10 to 20 years. The effect of a reduction in the amount of dredged material or possible interruption of the transport of dredged material to the processing facility was not necessarily factored into the unit cost. Interruptions of dredging due to seasonal restrictions, project funding, weather, contractual issues, and other circumstances will likely occur.

All baseline costs were extracted from vendor reports. For at least some of these demonstrations, one objective specified by New York and New Jersey sponsors was to demonstrate that sediment could be treated for under \$46/m³ (\$35/yd³), and this seems to be reflected in the resulting cost estimates. Reported treatment costs and expected revenues were therefore evaluated in this report for the purposes of:

- a. Formulating standardized conditions and assumptions, which can be used for an impartial comparative evaluation;
- b. Identifying potential costs not previously provided by the developers;
- c. Comparing costs and revenues of the treatment alternatives; and
- d. Developing a qualitative analysis of cost sensitivity to various operational/cost factors.

Treatment technology costs were adjusted to include the capital and operating costs that were not provided by the technology developer. The costs of items were estimated based on catalog prices, expert opinion, industrial engineering standards, and estimates provided for the other technologies. Table S3 provides the adjusted cost estimates for the various treatment technologies.

Benefit (potential revenues from the sale of beneficial use product) were based on market value of competing materials not associated with the presence of contaminants. Likely a performance history will have to be established before the full value of the beneficial use products can be realized.

Table S3. Adjusted cost estimates¹

Parameter	Rotary Kiln	Cement-Lock®	Minergy	BioGenesisSM
Total unit costs per in situ m ³ (yd ³)	\$120.28 (\$91.82)	\$132.52 (\$101.16)	\$93.99 (\$71.75)	\$68.11 (\$51.99)
Total cost minus benefits (potential revenues) per in situ m ³ (yd ³)	\$73.44 (\$56.06)	\$52.12 (\$39.79)	\$92.80 (\$70.84)	\$53.30 (\$40.69) ²

¹All costs were updated to December 2009 \$ using the *Engineering News Record* Construction Cost Index.

² Personal communication. August 23, 2010. John Sontag, Jr., Vice President, Director of Engineering, Biogenesis Enterprises, Inc., West Chester, PA.

The reader should not use the costs presented in this report as absolute costs, but instead should use them to provide relative comparisons of technology cost and performance. Actual costs must be determined on a site-by-site basis, and may be influenced by economies of scale, permitting and regulatory requirements, transportation costs for dredged material and residuals, disposal costs, permitting and regulatory requirements, sediment matrix effects, contaminant types and concentrations, market value of the beneficial use products, and technology maturity.

Some of the thermal technologies are capable of co-processing other waste streams along with sediment. The waste streams may provide calorific value, which can offset fuel costs, as well as providing value as a materials modifier. The result of such co-processing of mixed waste streams with sediment is potentially an improvement in the economics of the technology that may not be reflected by the cost estimates reported herein.

Current technology status

From the perspective of sediment volume treated, the demonstrations described in this document for thermal technologies have been limited to pilot scale, although some of the equipment may have been of sufficient scale to serve as part of a full-scale plant. The Biogenesis demonstration completed in 2006 consisted of all the components of a full-scale system and was operated at a full-scale processing rate (190,000 m³/year (250,000 yd³/year)), but continuous operations were limited to a few days at a time. There have been no subsequent sustained, full-scale sediment treatment operations and to date, the scale at which the technologies have been demonstrated is far less than the normal production rate of a commercial dredging operation.

There has been no further sediment treatment activity by JCI/Upcycle for the rotary kiln option since the 2000 pilot demonstration.¹ Although there reportedly is still a group interested in the use of the technology to process sediment, the premise of the technology developer was to use existing kiln operations. Although there are still some kilns operating in the New York area, whether there is still interest in processing sediment is unknown. The regulatory aspects related to permitting are expected to be significantly more difficult with respect to siting a new kiln, as compared to an existing one and this could be a key issue.

At this time, Minergy is not being actively marketed as a sediment treatment. Originally a subsidiary of Wisconsin Energy, the technology was sold in mid-2009 to a private concern², which is presently in the process of starting up the business. The company, which will again be known as Minergy Corp., is planning to pursue opportunities for sewage sludge treatment in Europe, but may have a future interest in this area³.

The controlling interest in Cement-Lock® was purchased in 2007 from the Gas Technology Institute by a private concern Volcano Partners, which has reportedly redesigned and re-engineered the concept to bring it up to commercial readiness⁴.

¹ Personal Communication. January 13, 2010. Jay Derman, Professional Engineer, Londonville, NY.

² Personal Communication. January 12, 2010. Bob Paulson, Senior Environmental Consultant, Wisconsin Energy Corporation, Milwaukee, WI.

³ Personal Communication. January 12, 2010. Craig Cameron, Co-owner, Minergy Corporation, Woodland Hills, CA.

⁴ Personal Communication. January 13, 2010. Al Hendricks, Managing Member, Volcano Partners, LLC, Mayland, FL.

1 Introduction

Background

What is the issue?

Highly contaminated sediments dredged from waterways, either for remediation purposes or to maintain navigation channels, present significant short- and long-term management challenges. Environmental organizations and other stakeholders generally favor treating contaminated sediments to destroy or remove contaminants, rather than long-term containment. Justification for pursuing treatment alternatives includes the following:

- National Contingency Plan (40CFR300.430) preference for reduction of toxicity, mobility, and volume through treatment for remediation projects
- Enhanced long-term environmental protection
- More sustainable alternative as disposal sites approach capacity
- Opportunity to transform contaminated sediments into a resource material that can be used beneficially and that has market value to offset cleanup costs

Treatment, while theoretically desirable, has proven to be difficult to implement for various reasons, including:

- Complexity of the sediment matrix and the presence of multiple contaminants
- Logistical issues, including disparate treatment and dredge production rates, large staging area and storage requirements, treatment plant siting restrictions, lack of treatment mobility
- Cost and logistics of dredged material transportation, process pretreatment and management of secondary waste streams generated during treatment
- Treatment cost versus cost of disposal
- Limited beneficial use opportunities for some decontaminated sediment products, market uncertainty for products, and the lack of a uniform treatment standard

- High initial capitalization costs coupled with short-term, intermittent or scattered demand
- Uncertainty regarding technology performance and cost

Purpose and relevance to the remediation project manager

This is intended to be a practical document providing an independent evaluation of the process performance reported by technology vendors of four processes that potentially produce beneficial products from contaminated sediment. The report synthesizes the information from multiple, comprehensive, project demonstration reports. This document attempts to impose a consistent structure on the comparative evaluation, from mass balance to cost estimating, such that it has utility for technology selection efforts, taking into account process requirements and their associated impacts on logistics and economics. Specifically, this document is intended to objectively assess the maturity, applicability and commercialization of these four treatment technologies demonstrated on contaminated sediments, by:

- Consolidating the mass balance information in a transparent manner
- Identifying any inconsistencies and data gaps in the process evaluations
- Providing a critical evaluation of the conclusions that can be drawn from the mass balances with respect to process efficiency
- Establishing a cost estimating template inclusive of pretreatment and residuals management
- Addressing logistical considerations for full scale implementation
- Presenting this information in a comparative fashion

What's in this report?

This report evaluates four technologies thought to be sufficiently developed to be commercialized. All of these technologies have the potential for producing a beneficial use product in conjunction with treatment of contaminated sediment. Chapter 2 contains technology briefs highlighting the major processes and considerations. Process flow diagrams (PFD), developed to reflect pre-treatment processes required for integration with a dredging operation and waste streams produced by the complete process, are included in Chapter 2. More detailed technology evaluations follow in Chapter 3 and include:

- Materials and contaminant mass balances, reconstructed on the basis of data obtained from published reports
- Performance evaluations, based on the reconstructed mass balances

Cost estimates are provided in Chapter 4 and include both estimated costs reported by the vendors and a template providing a uniform set of assumptions and cost factors.

Major technology development programs

To understand the “state of the practice” with respect to sediment treatment, it is helpful to examine the history of technology development. The majority of technical development appears to have been conducted under one of the five following federal and state programs:

- Superfund Innovative Technology Evaluation Program (SITE)
- Assessment and Remediation of Contaminated Sediment Program (ARCS)
- Contaminated Sediment Treatment Technology Program (CoSTTEP)
- Water Resources Development Act (WRDA) Sediment Decontamination Demonstrations
- New Jersey Department of Transportation’s Office of Maritime Resources (NJDOT/OMR) Sediment Technology Decontamination Demonstration Program

A brief description of each of these programs is provided in Appendix A. Despite the progress made in these demonstration programs over the course of more than 20 years, issues still remain that impede progress toward commercialization, including:

- Limited demonstrated scale
- Persistent logistical issues
- Cost uncertainty

In 2006-2007, however, two larger scale demonstrations were conducted in conjunction with the Passaic River remedial investigation. These offered the opportunity for a significant step towards commercialization for the two technologies evaluated (BioGenesisSM Sediment Washing Technology and Gas Technology Institute’s Cement-Lock[®]).

Overview of technology types

The goal of the first phase of this effort was to capture process demonstration histories and available performance data for selected technologies having the potential to treat sediments and produce beneficial products from contaminated sediments. As a first step, a search of the literature was conducted to identify technologies meeting the following criteria:

- Applied to contaminated sediments
- Demonstrated at pilot scale or greater in a technology verification program
- Having potential for commercialization or nearing commercialization
- Treating or immobilizing contaminants (metals and organics)
- Generating a product suitable for beneficial use
- Potential for scalability and mobility
- Sufficient data and information available in the public domain to facilitate analysis

Six technologies were evaluated in the first phase, representing one or more thermal, sediment washing and physical/chemical treatment technologies. The technologies and their beneficial use products were:

- Rotary kiln thermal treatment/light-weight aggregate (LWA)
- Cement-Lock® technology/Ecomelt® (cement)
- Minergy glass furnace technology/glass aggregate
- BioGenesisSM sediment washing technology/manufactured soil
- Solidification/stabilization technology/construction fill
- Harbor Resource Environmental Group, Inc. (HREG)/construction fill

Strictly physical technologies, such as solid separation, were not included since these address only volume reduction, not contaminant destruction or immobilization. Also, the operations utilized in solidification and stabilization are commonly practiced and non-proprietary options for immobilization technology are well developed.

The Harbour Resource technology, which combines chemical oxidation with stabilization, was considered initially. However, results of the demonstration conducted under the New Jersey Department of Transportation (NJDOT) Sediment Decontamination Demonstration Project did not demonstrate consistent effectiveness (NJDOT 2010).

Therefore, only the first four of the six technologies listed above were selected for comprehensive evaluation. Overall treatment performance was evaluated for each of the four technologies presented in this report. Process flow descriptions were developed in the context of the overall treatment operation, addressing mass balance, sediment decontamination, and reported residuals. Mass balance calculations were used to quantify mass removal efficiencies and to track contaminant fate. Vendor input was solicited to verify information and refine the initial analysis, which was based solely on published data. Data from the most recently documented demonstrations also were obtained from two of the vendors.

General considerations for technology selection

Pretreatment requirements

Technologies differ with respect to pretreatment requirements for the feed. All technologies will require removal of large-scale debris and sediment solids that are too large to pass through system pumps or that are too abrasive for specific pieces of equipment. Thermal technologies typically also require the moisture content of the feed to be reduced in dewatering and drying steps. The complexity of pretreatment requirements has the potential to significantly influence the cost of treatment, and should always be considered in any alternatives analysis where sediment treatment is being considered. These costs were not always reported in project reports, further complicating cost comparisons.

Decontamination or treatment efficiency

Some technologies may effectively treat the sediment without actually removing or destroying the contaminants. Through a variety of chemical reactions, contaminants can be immobilized in the treated sediment matrix such that they do not readily leach or volatilize, are not bioavailable, and therefore do not represent a significant environmental or human health risk. In other cases, the sediment is treated by transferring contaminants from the solid (sediment) phase to an aqueous phase, as in sediment washing, or to the gas phase, as in thermal desorption. In all cases, there may be some incidental contaminant losses or dilution in addition to contaminant reduction due to “treatment.”

Treatment efficiency (or percent removal) and decontamination are terms often used interchangeably as a measure of the contaminant reduction

achieved in the treated solids. As was implied in the preceding paragraph, however, a process may be efficient in terms of removing contaminant from the sediment without being efficient in terms of contaminant destruction. This report distinguishes between overall process efficiency (total output vs. total input), stage efficiency (stage output vs. stage input, *or* “*where in the process*” the treatment is occurring), and decontamination efficiency (final sediment concentration vs. initial sediment concentration). Each has different implications with respect to overall environmental impact, utility of additional treatment stages, magnitude of residuals, and contaminant levels in the final sediment product. To the extent practicable, this report also distinguishes between contaminant immobilization, contaminant destruction, and simple phase transfer of contaminants, the latter process resulting in residuals that must be managed.

Figure 1 provides an example of the different input and output streams for the overall process, for a single stage, for an offgas treatment stack, and for calculation of decontamination efficiency. This figure illustrates the importance of capturing data from all process streams in order to completely account for material and contaminant fate, and to provide a complete picture of how and where treatment is occurring.

Residuals treatment requirements

Processes that generate secondary process streams, such as wastewater or spent sorbent, are said to generate residuals. All treatment technologies produce some residuals, and these process streams also may require treatment and/or some type of controlled disposal. Processes that destroy or immobilize contaminants produce less residual than those that transfer contaminants from the sediment phase to another phase. Cost to manage residuals should be considered in feasibility evaluations. The physical characteristics of the residuals, such as grain size or water content, should be factored into the environmental suitability determination for managing residuals.

Mass balance—challenges and limitations

To describe the fate of contaminants in a treatment process, the movement of solid and liquid materials through the system must be considered in conjunction with the changes in contaminant mass or concentration. Contaminant reduction that might otherwise be ascribed to treatment may

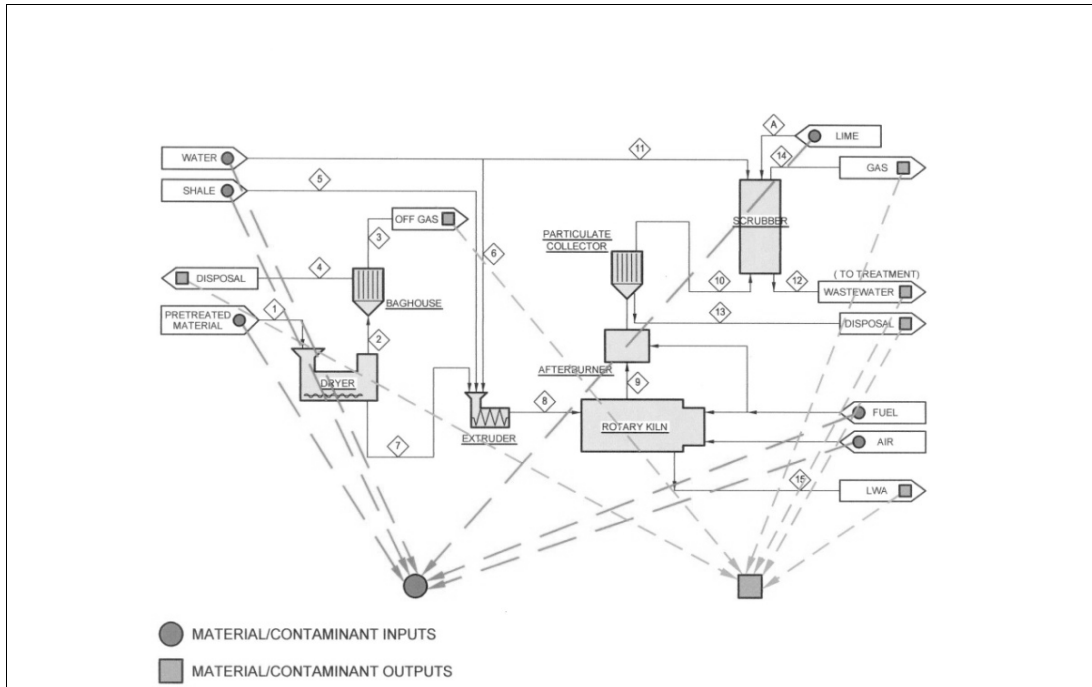

(a) Overall process efficiency—total inputs vs. outputs for the treatment system

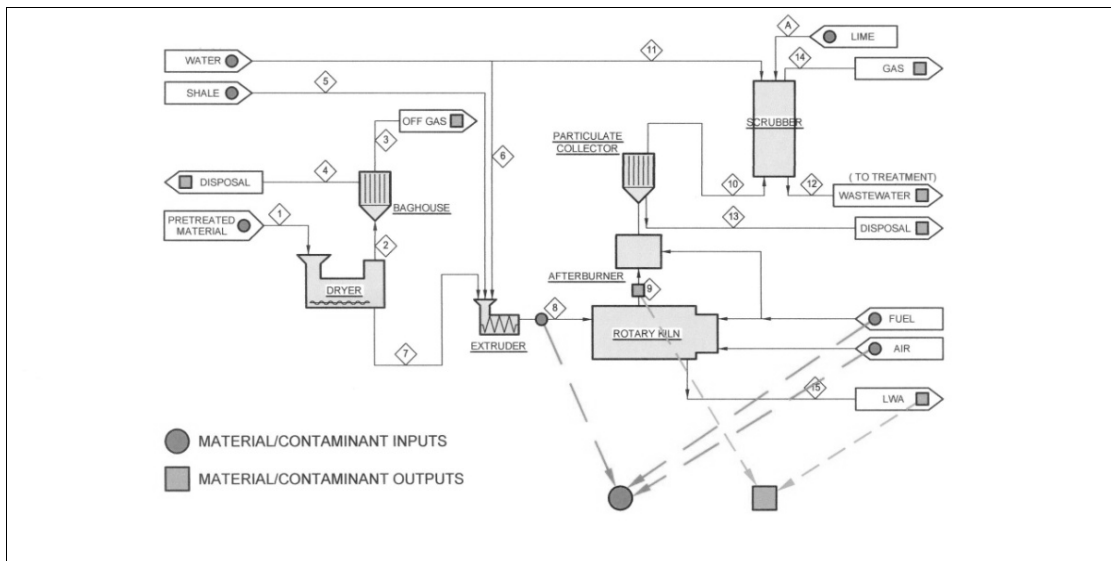

(b) Stage efficiency—e.g. inputs vs. outputs for the rotary kiln unit operation

Figure 1. Process efficiency accounting for a rotary kiln process (Continued)

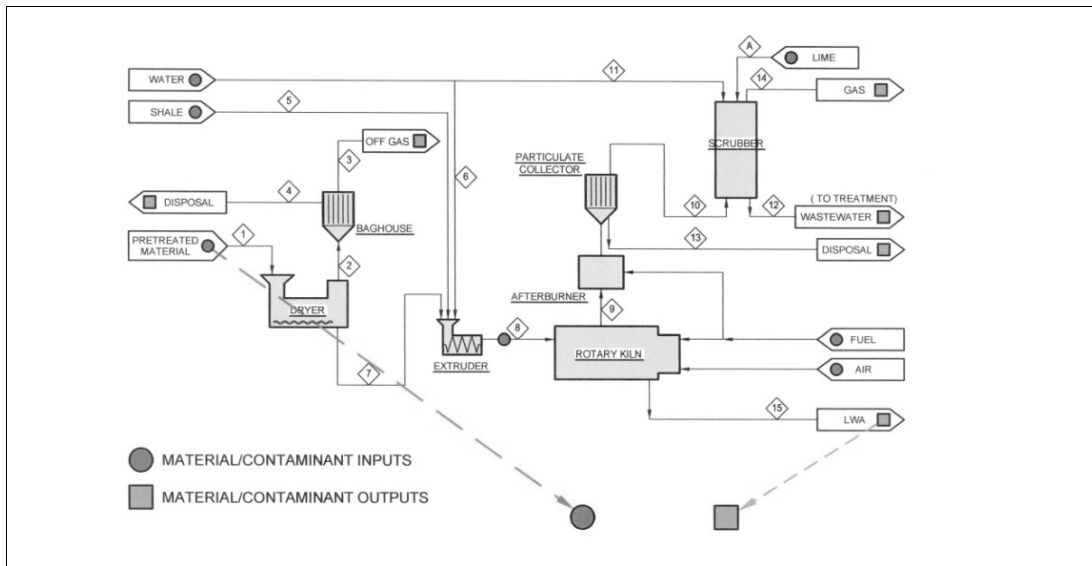

(c) Decontamination efficiency –feed contaminants vs. product contaminants

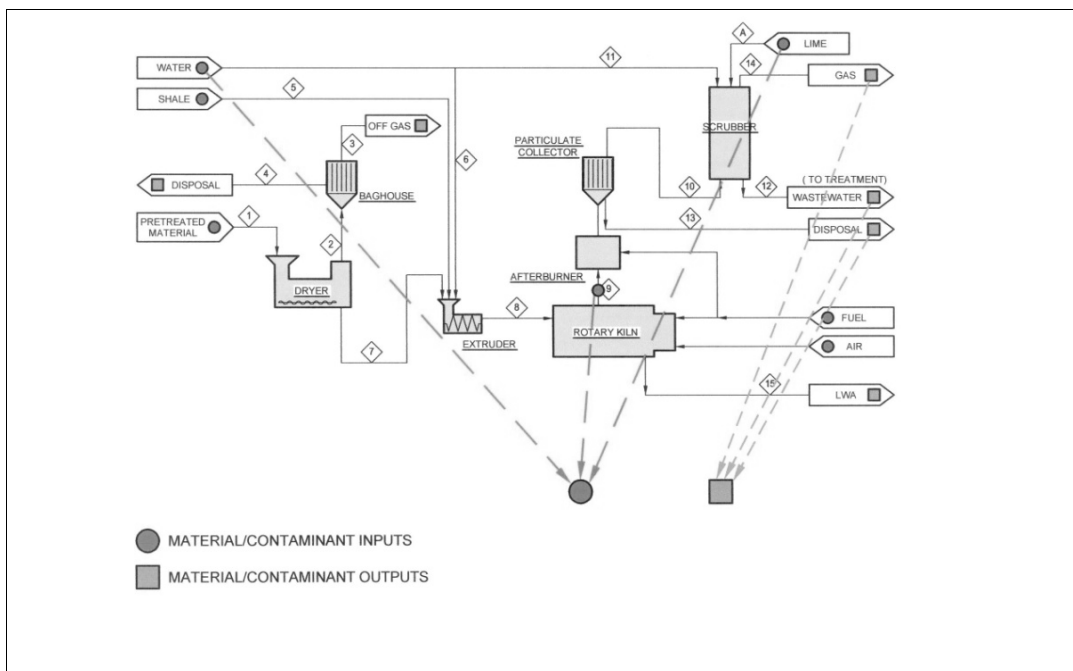

(d) Stack efficiency—stack contaminants vs. contaminants after emission controls

Figure 1. (Concluded)

be found to be due to loss of a particular size fraction of the solids, to transfer from the solid phase to the aqueous phase, or even to analytical limitations. Accounting for these different loss mechanisms is integral to understanding the manner in which treatment is achieved and the actual efficiency of the process. Obtaining data that fully account for all material and contaminant coming into, passing through, and leaving the system

can be challenging. Contaminants may be present at concentrations too low to detect but if the process stream is large enough (such as thermal offgases, for example), this may still represent a significant mass loss. Because one cannot follow a single sample through a treatment process, monitoring the actual effect of the process is hampered by the difficulty in discriminating between treatment effects and simple variability of the feed. For continuous processes, comparison of average sample properties for multiple samples taken over an extended period of time may provide the best indication of process performance. Representative sampling is integral to obtaining the best data possible and is always difficult, but especially so when dealing with slurries that have a tendency to settle in process vessels, or even while flowing through pipes, and offgas streams. Sampling points and method of capture should take material behavior into consideration.

Environmental dredging compared to navigation dredging

Navigational dredging is practiced worldwide to remove sediment as efficiently and economically as possible to maintain waterways for recreational, national defense, and commercial purposes (U.S. Environmental Protection Agency (USEPA) 2005). Use of the term “environmental dredging” has evolved in recent years to characterize dredging performed specifically for the removal of contaminated sediment from a waterbody for purposes of sediment remediation (USEPA 2005, Palermo et al. 2008). Environmental dredging is intended to remove sediment contaminated above certain action levels while minimizing the spread of contaminants to the surrounding environment during dredging (National Research Council (NRC) 1997). This report considers application of the four selected treatment technologies for sediment removed by both environmental dredging and navigation dredging.

Capacity and scale up

Capacity and scale up considerations for navigation dredging differ from those for environmental (remediation) dredging. Navigation dredging is typically conducted over a few weeks or months each year, often at different locations from year to year, at a production rate that far exceeds the capacity of any treatment technology developed to date. These conditions require a treatment technology to have high capacity while being either relatively mobile, or having a method of distributing loads over time, such as a centrally located plant convenient to multiple projects and perhaps capable

of processing multiple types of materials. Large capacity plants are not typically mobile, however, nor are they economical without a sustained and continuous feed supply, factors which impede the establishment of sediment treatment as a viable commercial operation.

Environmental dredging operations, particularly for Superfund sites, usually involve a finite volume that will be treated as a single project and that are smaller total volumes than navigation sites. For example, USEPA (2010) reports that of 60 Tier 1 Superfund sites, the volume of sediment removed was less than 38,000 m³ (50,000 yd³) at 50 percent of the areas, while the volume exceeded 800,000 m³ (1,000,000 yd³) at only 10 percent of the areas <http://www.epa.gov/superfund/health/conmedia/sediment/data.htm>. In contrast, the Corps of Engineers dredged more than 130 million m³ (170 million yd³) in Fiscal Year 2009 nationwide for navigation maintenance purposes (USACE IWR 2010 <http://www.ndc.iwr.usace.army.mil/dredge/dredge.htm>).

While typical navigation dredge production rates may range from 800 to 1500 m³/day (1,000 to 2,000 yd³/day), an environmental dredge may produce only 80 to 400 m³/day (100 to 500 yd³/day). Even at this reduced production rate, the environmental dredge may be limited to operating at 40 to 50 percent of capacity in order to keep the scale of land-based operations reasonable. Significant surge capacity and/or storage areas are typically required to address this disparity.

Economics

While all of the technologies demonstrated under the validation programs were required to provide cost estimates for operation at full scale, direct comparisons are difficult. Baseline assumptions differ considerably from one technology to another. The period of capital cost recovery, annual production, and assumptions regarding revenues produced from the sale of beneficial use product vary greatly. Further, what has often been missing from cost projections are costs associated with pretreatment, cost impacts of reduced dredge production, impact of intermittent or short-term feed supply and cost to treat and dispose of residuals. These are not insignificant issues. An estimate of the "integrated" cost of the treatment process, inclusive of these factors and derived from the same baseline, is needed for each of these technologies. Establishing a template for equivalent and realistic cost comparison is one of the objectives of this document.

The reader should not use the costs presented in this report as absolute costs, but instead should use them to provide relative comparisons of technology cost and performance. Actual costs must be determined on a site-by-site basis, and may be influenced by economies of scale, permitting and regulatory requirements, disposal and transportation costs for residuals, permitting and regulatory requirements, sediment matrix effects, contaminant types and concentrations, market value of the beneficial use products, and technology maturity.

Safety and public acceptability

Concerns regarding public health, safety, and comfort are common to all treatment technologies. Depending upon the type and degree of contamination, accidental inhalation, ingestion and skin contact with the raw sediments prior to or during processing can be a cause of concern for workers on site. Although the real versus perceived risk associated with exposure may be considerably different, potential for contaminant transport off-site is usually of concern to the general public, as are aesthetics, and impacts on property values and local traffic. The public will require reassurance of the safety of the process through analysis, testing, real-time monitoring, and adequate resolution of other issues.

Risks associated with all technologies include potential for contaminant losses through fugitive dust, volatile emissions, wastewater releases, incidental system failures and long-term leaching or volatilization from products. Sediments may produce toxic gases, such as hydrogen sulfide, during processing. Rowe, Klein, and Jones (1999) provide an evaluation of potential occupational, public, and environmental health risks from dredging, transporting, and treating contaminants in New York/New Jersey Harbor sediments. Appropriate gas monitoring devices, alarms, and ventilation systems may be required, particularly in enclosures, to ensure worker and community safety. Increased traffic in the vicinity of the treatment plant may pose a hazard, and certainly a nuisance, in some locations.

Hazards specific to thermal treatment technologies include high temperature zones within the plant, and potential for release of combustible gas mixtures from fuel supply lines, kilns, and afterburners. The normal equipment cool-down period may be as much as 24 hr. Multiple process trains would enable safe operation during equipment downtime. Redundant system safety shutoffs, gas monitoring devices, alarms, ventilation systems,

containment to restrict flow of fluid releases, or of the molten material in the event of catastrophic failure, elevated work platforms, emergency quench water and explosion-proof equipment can be employed to address these hazards as required by federal, state, and local regulations.

The sediment washing process evaluated here utilizes extremely high pressure (70,000 kPa (10,000 psi)) nozzles in conjunction with strong oxidants. Structural failure of pressurized lines is a potential risk. Even minor leaks can cause injury at these pressures. There is potential for chemical exposure to oxidants and lime during normal handling or as a result of equipment failure. Both solid and liquid forms may present contact, inhalation, and ingestion hazards. Solids in powdered form (such as activated carbon) pose the additional risk of asphyxiation due to oxygen depletion in the air. Forced ventilation, specialized storage and handling procedures, containment, spill kits, shower stations, personal protective equipment and emergency response plans should address these risks adequately.

Approval and permitting requirements

USEPA (1994, 2005) provide a partial list of federal environmental laws and regulations potentially applicable to a sediment remediation project. Permits may be required for specific remedial activities or for discharges that may result from these activities. For some regulations, the permitting and enforcement authority has been transferred to the state. Many states have additional laws and regulations that may be applicable to sediment remediation activities and to beneficial use of treated sediments. For example, the Great Lakes Commission (2004) developed a regional framework for upland beneficial uses of dredged material, which includes a compilation of applicable regulations from the Great Lakes states.

Technology evaluation measures

The selected technologies were compared based on a set of parameters adapted from EPA Region IX's technology evaluation protocol. The parameter list developed for this effort includes:

- Applicability--target contaminants/concentration ranges
- Engineering considerations
 - Pre- and post- treatment requirements
 - Continuous or batch operation

- Footprint
- Problems encountered
- System sensitivity to disruption/intermittent operations
- Capacity
- Developmental status
- Performance
 - Contaminant and material mass balance
 - Contaminant fate and removal mechanisms
 - * Phase transfer
 - * Immobilization
 - * Destruction
 - Effectiveness/efficiency
 - Nature and magnitude of process residuals
- Residuals and byproduct formation
- Beneficial use products
- Cost/economics

The following are some insights on the importance of these criteria.

In order to focus this effort on technologies that might reasonably be selected by a project manager, only technologies thought to be near commercialization were selected for evaluation. Applicability to the contaminants present at a site is an obvious selection factor. While there may be applications for contaminant-specific technology types, most contaminated sediments contain a mixture of contaminants, requiring a treatment technology capable of treating both organic compounds and metals. In addition, some technologies may be more effective on sediments with low to moderate contaminant levels, while others are equally effective for sediments with high contaminant concentrations. The level of efficiency needed versus the cost to achieve that level of efficiency is generally a consideration. Treating to a level suitable for beneficial use requires a different level of performance than treating to a level that will allow less restrictive and less costly disposal. All of the technologies considered here were demonstrated on multiple contaminant types.

The potential for formation of toxic treatment byproducts is obviously of concern to the communities where these technologies will be deployed, to regulators who permit the process, and to the project manager, who may have to manage residuals and protect against uncontrolled releases. Staging area requirements vary and may influence cost as well as applicability.

Having ample room to provide necessary surge capacity or equipment for slurry thickening, for example, can have a significant effect on the plant throughput; this in turn impacts dredge operating efficiency. Significant incompatibility of scale anywhere in the system (from dredge to product), potentially translates to increased cost.

Reliability of the processes considered is a factor difficult to assess at this stage of development. Most of the demonstrations encountered various problems, as would be expected, in growing the technologies from bench to pilot or larger scale. Long-term performance data are simply not available. Documenting conditions that were particularly problematic, however, is expected to be helpful to the remediation project manager in considering suitability for a particular site or material. The first two questions that are typically posed are, “How efficient is the technology?” and “How much does it cost?” Unfortunately, these are not simple questions to answer, but this report endeavors to evaluate the efficiency of the technologies on an equivalent basis, from the perspective that would be important to a consumer of the technology, and to extrapolate the cost data provided to facilitate unit cost comparisons. The results of those efforts follow in the Technology Briefs and Mass Balance Evaluation sections (Chapters 2 and 3) and the Cost Evaluation section (Chapter 4).

2 Technology Briefs

General information

Three of the technologies included here are thermal technologies, and one is an ambient temperature, physical-chemical technology. Tables 1 and 2 provide a concise comparative summary of the major technology characteristics. Of the technologies listed, three have undergone multiple bench-, pilot-, or large-scale trials on contaminated sediments (Cement-Lock[®], Minergy and BioGenesisSM). Only the most significant or most recent demonstrations (for which reports were available) are referenced in Table 2, however, as these best reflect the current developmental status of the technologies. A more complete history of each technology's development is captured in references to previous demonstrations and testing which are provided in this chapter and Chapter 3.

Table 1. Comparisons of treatment mechanisms, beneficial use products, and area requirements for selected processes.

Technology	Process Type	Treatment Mechanism		Beneficial Use Product	Operation	Footprint
		Organics	Metals			
JCI Upcycle/ Rotary Kiln	Thermal	Thermal decomposition, volatilization	Immobilization, volatilization, dilution ¹	Lightweight aggregate	Continuous	2300 m ² (0.6 acre) (Pre-treat)
Cement-Lock [®]	Thermal	Thermal decomposition, volatilization	Immobilization, volatilization, dilution ¹	Ecomelt [®] (cement additive), EcoAggMat (aggregate), Power	Continuous	4046 m ² (1 acre) (process module)
Minergy	Thermal	Thermal decomposition, volatilization	Immobilization, volatilization	Glass aggregate, electrical generation potential	Continuous	4645 m ² (1.1 acres)
BioGenesis SM	Physical-chemical	Oxidation, cavitation, phase transfer	Particulate separation and phase transfer	Soil	Continuous	8250 m ² (2 acres) (projected)

¹ Incidental dilution may occur as a result of blending dredged material with additional solid materials to enhance the physical properties of the product.

Table 2. Comparisons of operational characteristics for selected processes.

Technology	Mobility	Demonstrated Scale	Demonstrated Capacity	Pretreatment Requirements	System Inputs	Process Residuals
JCI Upcycle/ Rotary Kiln	Not mobile	3.06 m ³ (¹) (4 yd ³ (¹))	Hammermill dryer – 22.7 kg/hr (50 lb/hr) filter cake Kiln – 19.4 kg/hr (42.8 lb/hr) pelleted feed rate	Removal of large debris and +12.7 mm (½-in) materials, dewatering, (drying integral to process)	Air, fuel gas, water, shale, sodium hydroxide (scrubber)	Debris, offgases and particulates, scrubber wastewater,
Cement-Lock®	Potentially modular, scalable, barge mounted	89.3 metric tons(²) (100 tons(²)), 28.6 metric-tons(²) (32 tons(³))	0.45 metric tons/hr (0.5 ton/hr)	Removal of large debris and +50.8 mm (2-in) materials, dewatering, drying	Air, fuel gas, modifiers, water, lime (scrubber)	Debris, offgases and particulates, spent carbon
Minergy	Not mobile	Sediment <7.65 m ³ (<10 yd ³), sewage and paper plant sludge – 1160 metric tons/day(⁴) (1300 tons/day(⁴))	Plant – 383 dry metric tons (500 dry tons) sewage sludge/day, 153 metric tons/day (200 tons/day) glass aggregate production	Removal of large and small debris and metal objects, dewatering, (drying integral to process)	Lime (dewatering), oxygen, fuel gas, flux, water	Debris, offgases and particulates, scrubber wastewater, spent carbon
BioGenesis SM	Semi-Mobile ⁸	497 m ³ (⁵) (650 yd ³ (⁵)) 329 m ³ (⁶) (430 yd ³ (⁶)), 11,500 m ³ (⁷) (15,000 yd ³ (⁷))	Pilot - rate 29.8 m ³ /hr(⁵) (39 yd ³ /hr (⁵)) 15.3 m ³ /hr (20 yd ³ /hr) @32% solids by weight (⁶), Full sale rate 29.8 m ³ /hr(⁷) (39 yd ³ /hr (⁷))	Removal of large debris and +6.35 mm (¼-in) materials	Water, surfactants, oxidizers (hydrogen peroxide, sodium percarbonate), polymers (dewatering)	Debris, wastewater

1 Stratus Petroleum site sediments, 2001

2 Stratus Petroleum site sediment, International Matex Tank Terminal, Bayonne, NJ 2005

3 Passaic River sediments extended duration tests, International Matex Tank Terminal, Bayonne, NJ. Dec 2006 & May 2007

4 Fox Valley Glass Aggregate Plant, Neenah, WI

5 Stratus Petroleum - Newark Terminal Site located in Newark, New Jersey on upper Newark Bay, lower Passaic River

6 Port of Venice, Porto Marghera, Venice, Italy, Winter 2003/2004

7 Raritan River, Arthur Kill and Passaic River sediments, Bayshore Recycling facility, Kearny, NJ 2006

<http://www.state.nj.us/transportation/airwater/maritime/dresediment.shtm> (accessed 01-11-10)

8 Equipment is transportable, but would require some site set-up

JCI/Upcycle Rotary Kiln brief

Synopsis

This thermal technology utilizes a rotary kiln, a mature and commercially available process that is durable and able to incinerate wastes over a wide range of sizes and composition. Lightweight aggregate (LWA) products are generated by heating certain types of clay, shale, slate, or other materials in the rotary kiln (Figure 2). Temperatures in the kiln exceed 1400° C (2500°F) and cause the materials to expand or "bloat" as organics volatilize. The process results in a light, porous product that retains its physical strength when cooled.

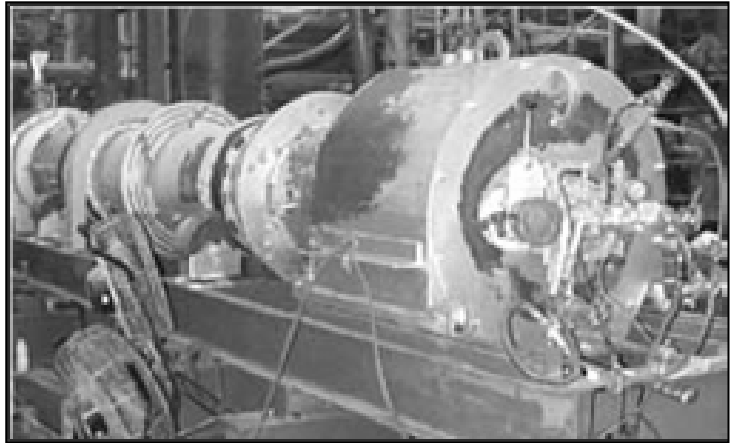

Figure 2. Rotary kiln (from NJDOT project update sheet).

Applicability

The rotary kiln technology, like all thermal technologies, should be effective for treatment of most organics and metals at a wide range of contaminant concentrations. Some contaminants may remain leachable at minimal levels in the LWA product, however (see process efficiency discussion). Whether a thermal technology represents the best choice for a particular site will depend upon the site-specific treatment objectives (what efficiency is really needed?). Where contaminant concentrations are relatively low, other non-thermal treatment options may be sufficiently effective and less energy-intensive.

Engineering considerations

The integrated treatment process consists of two distinct phases: (i) particle size reduction and dewatering of the raw feed, and (ii) the rotary kiln or treatment phase (Table 3, and Figures 3 and 4). Drying is integral to the proprietary process as configured, but may be an external process. In the size reduction stage, debris and solids larger than 12.7 mm (½-in.) (gravel, and cobbles) are removed or separated from the sand and fine fraction. Where mechanical dewatering is employed and a significant sand fraction is present, sand may also be separated from the fines and allowed

Table 3. Rotary kiln process stages.

Stage	Function	
Non-Proprietary Stages	Grizzly (or comparable)	Removal of oversize particles and debris
	Screen and filter press (or comparable)	Separation and removal of sand, dewatering of fines
Proprietary Stages	Dryer	Further reduction of water content in dewatered fines (filter cake)
	Extruder	Addition of shale (raw material) and water (to optimize water content), extrusion as pelletized feed for kiln
	Kiln	Contaminant volatilization, thermal decomposition of organic compounds, immobilization of metals in melt
	Offgas treatment	Secondary combustion, particulate collection, sodium hydroxide addition as pH modifier (lime may be added for mercury control)

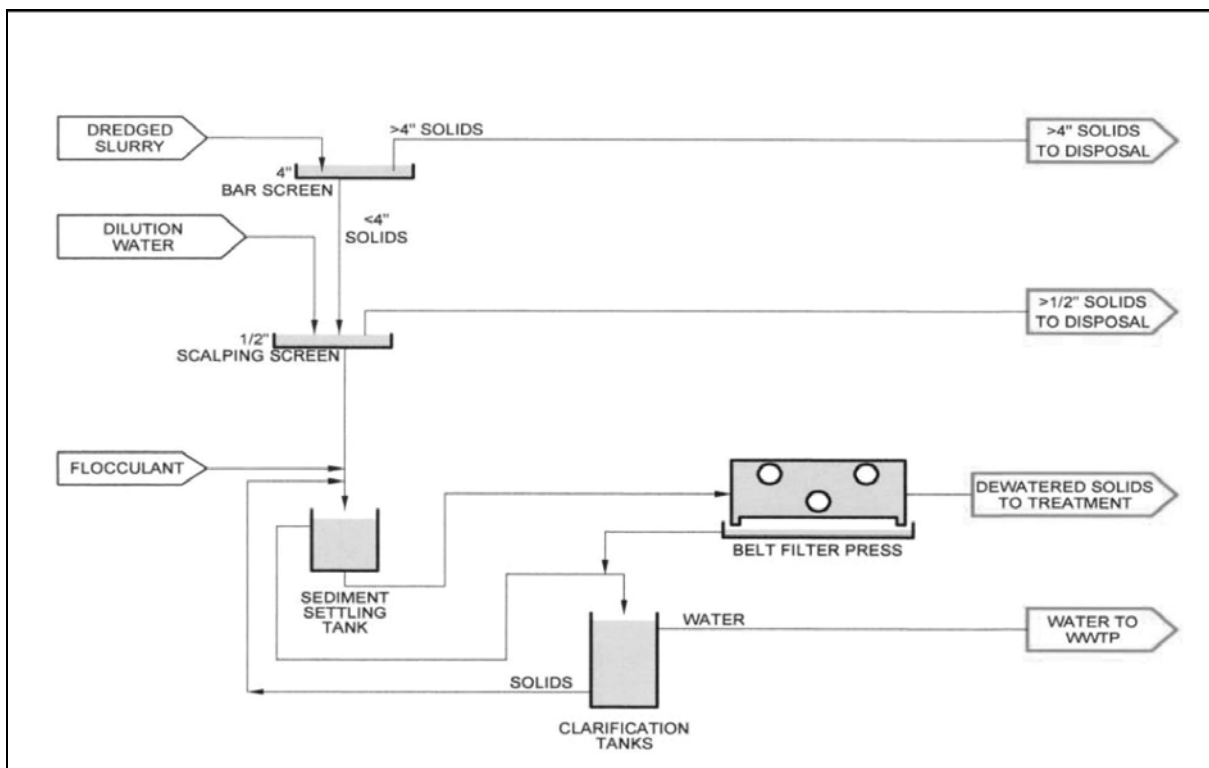

Figure 3. JCI/Ucycle rotary conceptual kiln pre-treatment flow diagram.

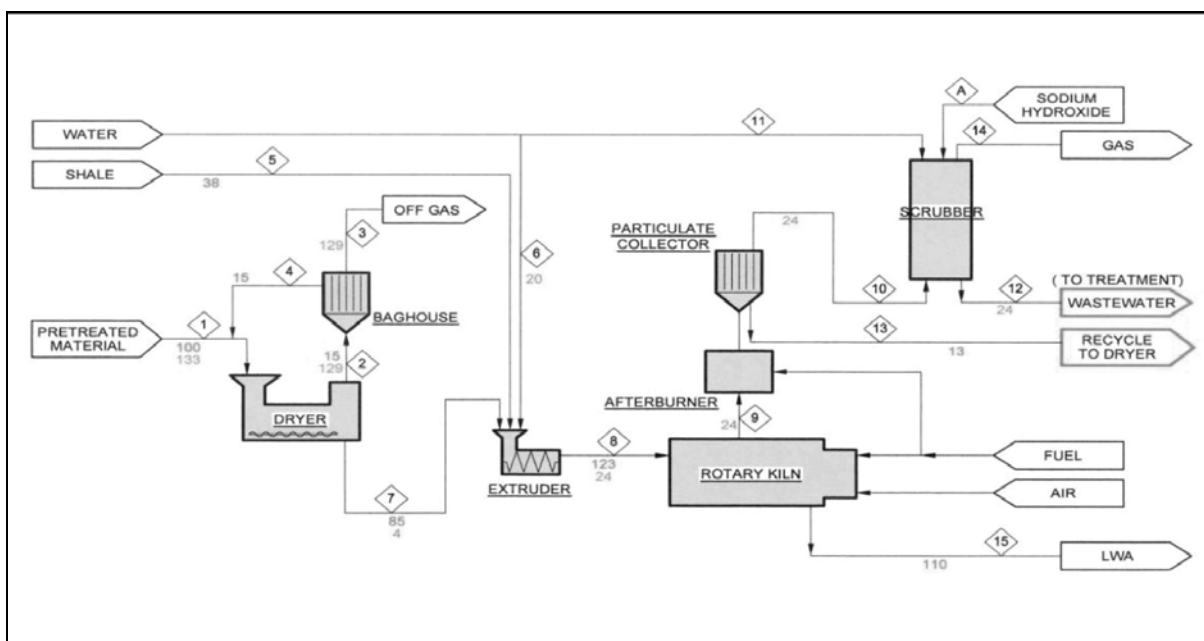

Figure 4. JCI/Ucycle rotary kiln process flow diagram.

to dewater by gravity, and the fine fraction is mechanically dewatered. The oversized materials are cleaned and disposed of as appropriate, and the dewatered fines, or fines recombined with sand, are fed to the system.

The rotary kiln process is a continuous operation. Processing interruptions are detrimental to equipment due to the extreme thermal stresses that result, and may also contribute to undesirable product variations (JCI Ucycle Associates, LLC 2002). Sufficient staging and storage area is therefore required to assure continuous feed. Storage area requirements are dictated by the respective dredging and dewatering production rates and the achievable kiln feed rates at full scale.

Developmental status

Pilot Demo (2000) - The process was demonstrated on sediments from the Stratus Petroleum site in New Jersey, as part of comparative technology demonstrations conducted by the NJDOT.¹ Although the pilot scale demonstration was promising and larger scale demonstrations were planned, no subsequent demonstrations have been conducted to date. A 2004 project update sheet is also available on the NJDOT site.²

¹ <http://www.state.nj.us/transportation/airwater/maritime/dresediment.shtml>

² <http://www.state.nj.us/transportation/airwater/maritime/pdf/upcycleupdate.pdf>

Performance

Contaminant fate/treatment mechanisms

Mass balance data for the June 2000 pilot study were reported in JCI Upcycle Associates LLC (2002)¹. Review of the mass balance data suggests both incidental loss mechanisms and contaminant mass reduction attributable to treatment processes. Incidental losses account for contaminant mass removed from the feed sediment due to processes that accompany the primary treatment unit but are not the principal treatment mechanism.

Incidental contaminant reduction and losses

Based on pilot test results, some contaminants may evidence as much as 15 to 20 percent contaminant mass loss in the dewatering phase, possibly attributable to incidental volatilization. (In the pilot study, benzo-a-pyrene, fluoranthene, mercury are examples of this loss.) A percentage of more readily soluble contaminants also may be lost to the filtrate in this phase, with amounts ranging from 4 to 23 percent observed for metals in the pilot testing. Concentrations of organic compounds in filtrate were largely non-detect or below quantitation limits, suggesting minimal losses, although trace levels of some dioxin/furans were detected. Some contaminants also may be lost in the drying step, due to volatilization or particulates lost to the off-gas stream. Volatiles, metals, and combustion byproducts passing through the afterburner may be captured in the gas scrubber downstream of the kiln, minimizing losses to the atmosphere.

Some contaminant dilution will be achieved due to the addition of shale to the dewatered sediment feed. Shale was added to enhance the properties of the LWA product, but the rotary kiln can produce an LWA using 100% dredged material. In the pilot test, the feed ratio was 70% dewatered sediment to 30% shale (by weight). Based on this feed ratio, up to 23 percent reduction of contaminant concentration in product may be attributable to dilution (assuming no incoming contaminants with the shale).

¹ <http://www.state.nj.us/transportation/airwater/maritime/pdf/upcyclefinalrpt.pdf>

Treatment mechanisms

Thermal decomposition of organic contaminants occurs in the rotary kiln, where materials are tumbled to enhance contact with hot burner gases, and also in the afterburner, where volatile organics lost to the offgas stream are incinerated.

Residual metals are largely immobilized in the product matrix, though some may be slightly leachable under favorable conditions.

Capacity

Demonstrated capacity - 2000 Pilot Demo – 3.1 m³ (4 yd³) total volume treated, 19.4 kg/hr (42.8 lb/hr kiln feed rate).

Projected Capacity – 380,000 m³ (500,000 yd³) (in situ)/year (based on economies of scale assumed to be requisite to economic sustainability (JCI Upcycle Associates, LLC 2002). Projected baseline throughput of separation and dewatering plant: 1419 L/min (375 gpm) at 10% solids per 2.79 m² (30 ft²) of “primary dewatering module separation panel” (inclined screens). Projected LWA production rate of 12.5-19.6 metric tons/hr (14-22 tons/hr to support a 380,000 m³/year (500,000 yd³/year throughput, subject to corresponding kiln capacity).

Efficiency/effectiveness

Most of the technology demonstration reports included estimates of process efficiency, and values can be found for the rotary kiln technology in the documents referenced in the section titled “Technology references/reports.” However, in order to provide an equivalent basis for technology comparisons, process efficiencies consistent with the definitions provided in the section titled “Mass balance-challenges and limitations” were calculated as part of the analysis presented in this document. The data and mass balance evaluation are more fully discussed in the section titled “JCI/Upcycle Rotary Kiln mass balance” and Appendix B. A synopsis of resulting efficiencies is incorporated here.

Overall efficiency: Overall process efficiency reflects not only the efficiency of treatment but also the magnitude of all residuals. Overall process efficiency was calculated as in Equation 1, where *Mass* is contaminant mass:

$$E_{overall} = \frac{\sum Mass_{in} - \sum Mass_{out}}{\sum Mass_{in}} * 100 \quad (1)$$

Contaminant mass inputs:

- Filter cake (total concentrations)
- Shale (total concentrations)
- Scrubber water (total¹ concentrations)

Contaminant mass outputs:

- Aggregate (total and Toxicity Characteristic Leaching Procedure (TCLP) leachable concentrations)
- Baghouse solids (total concentrations)
- Ceramic filter solids (total concentrations)
- Scrubber liquor (total² concentrations)
- Offgases (in this case, mass lost to the vapor phase could not be calculated due to data limitations)

Stage efficiency: Efficiency of the kiln treatment was calculated as for overall efficiency, assuming:

Contaminant mass inputs:

- Feed pellets (from extruder) (total concentrations)

Contaminant mass outputs:

- Ceramic filter solids (total concentrations)
- Aggregate (TCLP leachable concentrations)
- Offgases (neglected in this case)

With some exceptions, overall efficiency for metals based on extractable mass in the aggregate and total mass in process waste streams, ranged from 59 to 88 %³; mercury efficiency was 64 %, likely reflecting the tendency of

¹ The report does not clearly specify whether reported concentrations are total or dissolved fraction. Scrubber liquor appears to have been digested, however, which suggests that those results reflect total metals concentrations. Total concentrations would be desirable for this computation.

² *Ibid.*

³ Where TCLP contaminant mass exceeded residual contaminant mass in the aggregate, the residual mass was used in calculating efficiency.

this metal to volatilize. Most semi-volatile compounds were non-detect in the pelletized feed. For those having at least one positive identification in both input and output streams, overall efficiency ranged from 75 to 85 percent with the exception of bis(2-ethylhexyl) phthalate, where output mass was greater than input mass. Measured polychlorinated biphenyl (PCB) mass yielded an 84% overall efficiency. Significant PCBs mass loss (14.6%) was attributed to dust lost during the hamermill drying step prior to the kiln.

Kiln stage efficiency for most polynuclear aromatic hydrocarbons (PAHs) ranged from 97 to 100 percent. Exceptions included phenanthrene (45 percent), fluoranthene (92 percent) and naphthalene (higher in kiln output than in kiln input). Kiln stage (not including the afterburner) efficiency for total PCBs was 57 percent. Excluding mercury, stage efficiency for metals (reflecting effective immobilization) ranged from 46 to 99 percent (with output exceeding input for cadmium) based on the lesser of total mass or TCLP leachable mass (where TCLP results were available for particulates). Kiln stage efficiency for mercury was approximately 46 percent, again reflecting the tendency of this metal to volatilize to the offgas stream. Full-scale equipment could include additional controls in the secondary combustion chamber and the baghouse for capture of mercury in the offgases.¹

Decontamination efficiency: The reduction in contaminant mass in the sediment was estimated by comparing input mass of the process feed (filter cake) to both residual and (TCLP) leachable contaminant mass in the aggregate. Based on residual mass, decontamination efficiency ranged from 27 to 100% for metals, and was effectively 100% for all organics. Because metals are immobilized but not destroyed, the absence of metals from aggregate digestions is evidence of material variability or incidental losses to other process streams rather than treatment per se. Based on leachable contaminant mass, however, decontamination efficiency ranged from 94 to 100 percent for TCLP metals.

Contaminant extractability: TCLP testing was employed to evaluate the potential mobility of residual contaminants in the aggregate. TCLP extractions of the aggregate reflected measurable concentrations of metals, while herbicides, pesticides, PCBs, volatile organic compounds (VOCs) and

¹ Personal Communication. 2010. Jay Derman, Professional Engineer, Loudonville, NY.

semi-volatiles (SVOCs) were all non-detect. TCLP metals measured in LWA were reported to be below criteria, however TCLP metals were also below criteria in the filter cake (dewatered process feed). Fewer TCLP results were provided for filter cake than for aggregate, limiting the number of comparisons that could be made between treated and untreated material to four metals. Comparative results expressed as the percent mass fraction of contaminant extractable for filter cake and aggregate are given in Table 4. The fraction extractable in the aggregate was approximately an order of magnitude lower than in the filter cake for arsenic and was effectively zero for chromium and mercury. The fraction of barium and lead extractable in the aggregate was approximately five times higher than in the filter cake, however.

Table 4. Percent contaminant mass extractable by TCLP.

Contaminant	Filter Cake	Aggregate
Arsenic	19.8	1.07
Barium	1.87	11.4
Cadmium	8.12	ND
Chromium	0.03	ND
Copper	a	2.64
Iron	a	7.00
Lead	0.22	1.0
Magnesium	a	3.79
Manganese	a	3.37
Mercury	0.03	ND
Nickel	a	3.12
Potassium	a	14.3
Selenium	0	ND ^b
Zinc	a	32.0
^a Missing filter cake TCLP. ^b Non-detect in aggregate, measurable in TCLP extract.		

Contaminants present in the shale could in some cases be responsible for higher residual concentrations of metals in the aggregate, but should not result in higher TCLP concentrations if the metals were effectively immobilized.

Residuals and byproducts

Assuming the LWA is sufficiently decontaminated to permit beneficial use, the process residuals requiring management include those listed in Table 5. Hydrogen sulfide (H₂S) generation was not an issue for this demonstration but has been problematic with other fully housed dewatering operations, requiring use of protective equipment or specialized ventilation and monitoring systems (sulfide content of sediment will be a factor). Measurable concentrations of mercury, sulfur dioxide (SO₂), nitrous oxides (NO_x), carbon monoxide (CO), and VOCs were detected in the dryer offgases, along with low, but measurable, concentrations of PCDDs and PCDFs. No SVOCs were reported. Emissions from the dryer outlet would likely be captured as part of the overall offgas treatment in a full-scale process, and would be managed as part of that process stream. Reported scrubber emissions, which represent the contaminant releases to atmosphere from the offgas stream, included measurable concentrations of several metals, VOCs, some SVOCs, PCBs, chlorine, SO₂, NO₂, and CO. During normal operations all scrubber liquor and wash water could likely be recycled within the plant, minimizing or eliminating wastewater production.

Beneficial use end product

A light-weight aggregate (LWA) product results from the heating and expansion of the shale/sediment feed pellets in the kiln. More product specifications are provided in the mass balance chapter and in the final report from the pilot process demonstration.¹ The vendor reports that there is an identified market for 820,000 metric tons (mtons) (900,000 tons) of lightweight aggregate in the Northeastern US area,² although no further specifics were provided. The commercial value of lightweight aggregate is reported in one reference at \$55 to \$83/mton (\$50 to \$75/ton) (Seager and Gardner 2005).

Cost

Normalized cost (December 2009 cost basis):

- exclusive of revenues: \$91.82
- inclusive of estimated revenues \$56.06.

¹ <http://www.state.nj.us/transportation/airwater/maritime/pdf/upcycleupdate.pdf>

² <http://www.state.nj.us/transportation/airwater/maritime/pdf/upcycleupdate.pdf>

Table 5. JCI/Upcycle process residuals—character and relative magnitude.

Stage		Residual	Magnitude	Detected Parameters																					
				Metals	PCBs	SVOCs	VOCs	Halogens	Chlorine	Ammonia	Herbicides	Pesticides	SO _x	NO _x	CO	H ₂ S	PCDDs/PCDFs	TCLP Volatiles	TCLP Semi volatiles	TCLP Metals	MEP Metals	Suspended Particulate	Condensable Particulate	Total Particulate	
Pretreatment	Debris Removal	Debris	Not reported																						
		Wash water	Not reported, could be recycled within process	P ³	P ³	P ³	P ³			P ³	P ³	P ³				P ³								A	
	Dewatering	Filtrate	No volume reported. Could be recycled within process for slurry dilution or wash-water.	X ¹	P ³	P ³	P ³			P ³	P ³	P ³			P ³	P ³									
		Volatile Emissions	See final report for mass production rates by contaminant	A ²	P ³	P ³	P ³			P ³					P ⁴										
Offgas Treatment	Dryer	Volatile Emissions	See final report for mass production rates by contaminant	X ⁷	P ³	P ³	X						X	X	X		P ³								
		Particulate	0.5 kg/metric ton (1 lb/ton) of the dewatered solids coming into the dryer lost to the offgases	X	X	X					P ³	P ³					X								
	Baghouse/Ceramic Filter Catch	Sediment Particulates	0.26% of feed pellets to rotary kiln lost to baghouse/filter catch	X ⁸	ND	X ⁵	X ⁵					ND	ND				X	X ⁵	ND	X	X				

Stage	Residual	Magnitude	Detected Parameters																						
			Metals	PCBs	SVOCs	VOCs	Halogens	Chlorine	Ammonia	Herbicides	Pesticides	SO _x	NO _x	CO	H ₂ S	PCDDs/PCDFs	TCLP Volatiles	TCLP Semi volatiles	TCLP Metals	MEP Metals	Suspended Particulate	Condensable Particulate	Total Particulate		
Offgas Treatment	Scrubber	Wastewater	0.1 lb/lb dewatered solids for pilot. May be reduced by recycle.	X ⁶	X ⁶	X ⁶																			A
		Volatile Emissions	See final report for mass production rates by contaminant. As demonstrated, approx 1 lb water (as vapor)/ lb filter cake processed through dryer and kiln collectively	X ⁹	X ⁹	X ⁹	X	ND	X	ND			X	X	X		X						X	X	X
		Spent Carbon	Not demonstrated but possibly required at full scale for control of byproducts and fugitive contaminant emissions																						

P Potential, if present in sediment
X Detected at measurable concentrations
A Assumed to be an operative contaminant loss mechanism
ND Non detect
1 As demonstrated, As, Mn and Hg exceeded WQC in filtrate, but testing demonstrated not at toxic levels. Filtrate concentrations represent from 1.5% (Hg) to 23% (Ni) of bulk metals mass in-situ.
2 For Hg, over 20 % Hg mass unaccounted for after dewatering step
3 Some volatile losses possible if present
4 May be generated with exposure of sulfide-bearing sediments
5 Limited number of constituents detected
6 From 0 to 2 percent of incoming filter cake metals mass
7 Approximately 10% of incoming filter cake mercury mass
8 Particulate associated metals mass <2 % of filter cake metals mass, except for Pb (13 %) and Cd (30 %)
9 Less than 0.03% total metals, 1% PCBs, up to 10% PAHs

Reported costs were provided by the vendor, and reflect estimates of full-scale operation based on results of the pilot demonstration. Reported costs are predicated on a 380,000 m³ (500,000 yd³) (in situ waterway sediment) annual treatment volume, and a 30-year operating (capitalization) period. The reported unit cost includes an estimate for “dewatering and kiln processing.” The cost for LWA processing including all required pollution control was not included since the business model envisioned using existing LWA facilities. The cost of LWA processing and of revenue from product sales accrued to the LWA facility. More detailed information regarding the basis of the reported unit cost is included in Chapter 4 (Cost Evaluation).

Normalized unit cost reflects the incorporation of missing cost elements to provide an equivalent basis for comparison to other technologies. Cost estimates for this and the other technologies evaluated here had to be reconstructed based on the same capacity and capitalization assumptions and including all processing and operating cost elements. The procedure by which these “normalized” unit cost estimates were developed, and the sensitivity of the unit cost estimates to major cost factors (plant capacity, energy, residuals treatment, labor, capital and operating costs, and assumed beneficial use product value) are also more fully described in Chapter 4.

Technology references/reports

JCI/Upcycle Associates, LLC 2002. “Final Summary Report, Sediment Decontamination and Beneficial Use Pilot Project”, Prepared for New Jersey Department of Transportation, Office of Maritime Resources, Project AO#9350203 and United States Environmental Protection Agency – Region 2, through Brookhaven National Laboratory, Contract Number 48172, Upton, NY.

New Jersey Department of Transportation. 2004. *Sediment Decontamination Demonstration Program Project Update for Upcycle Associates, LLC*. Office of Maritime Resources. Last Updated: February, 2004”, <http://www.nj.gov/transportation/airwater/maritime/pdf/upcycleupdate.pdf>

Technology points of contact

Jay Derman, P.E.
P.O. Box 11369
Loudonville, NY 12211
518-463-0905
jderman@nycap.rr.com

Cement-Lock® brief

Synopsis

The Cement-Lock® technology pictured in Figure 5 is a proprietary thermo-chemical remediation technology that converts contaminated sediment into end product material that can be used as a partial replacement for cement in the production of concrete. In the Cement-Lock® process, a mixture of sediment and modifiers is charged to a rotary kiln (the “Ecomelt® Generator”), which is the core of the treatment process. The integrated treatment process consists of two distinct phases: (i) solid separation (size reduction), dewatering and drying of the raw feed, and (ii) the rotary kiln (treatment) phase.

Table 6 summarizes the principal unit operations in each of these phases. A process flow diagram for the Cement-Lock® technology is provided in Figure 6. Prior to treatment, debris and solids typically larger than 50 mm (2 in.) (gravel and cobbles) are removed or separated from the sand and fine fractions. Oversized materials are cleaned and disposed of as appropriate. For mechanically dredged sediment, the bulk sediment is dewatered and dried, and subsequently blended with modifiers and fed to the kiln (or “Ecomelt® Generator”) as shown in Figure 6. For hydraulically dredged sediment, separation of the sand would normally be necessary prior to mechanical dewatering of the fines, and the dewatered materials would then be recombined, blended with modifiers, and fed to the kiln. The system has a footprint of approximately 4,000 m² (1 acre), is potentially modular, and could be barge-mounted for mobility.

Applicability

Cement-Lock®, a thermal technology, is applicable to sediments with a wide range of contaminant concentrations. Kiln residence times and temperatures (1,400 to 1,500 °C (2,600 to 2,700 °F)) are sufficient to achieve thermal destruction of most organics and immobilization of heavy metals (Rehmat et al. 1999 a, 1999b). Volatile metal species and thermal breakdown products generated in the process must be captured from the



Figure 5. Cement-Lock® demo plant (Mensinga 2008a)

Table 6. Cement-Lock® process stages

Stage		Function
Non-Proprietary Stages	Grizzly (or comparable)	Removal of oversize and debris
	Crusher	Reduction of particle size to <50 mm (<2 in). ¹
	Dryer	Water content reduction of crushed feed ¹
Proprietary Stages	Ecomelt® Generator	Contaminant volatilization, thermal decomposition of organic compounds, immobilization of metals in melt
	Secondary Combustion Chamber	Further contaminant destruction in offgases
	Ecomelt® Granulator	Cooling, granulation of the melt
	Grinder	Size reduction of melt
	Heat recovery, lime injection, , baghouse filter, carbon column	Offgas cooling, with lime injection as SO _x and HCl adsorbent, particulate collection and contaminant (Hg) sorption

¹ For hydraulically dredged material, a dewatering step would be required in order to reduce the water content of the sediment prior to crushing, drying, and blending with modifiers.

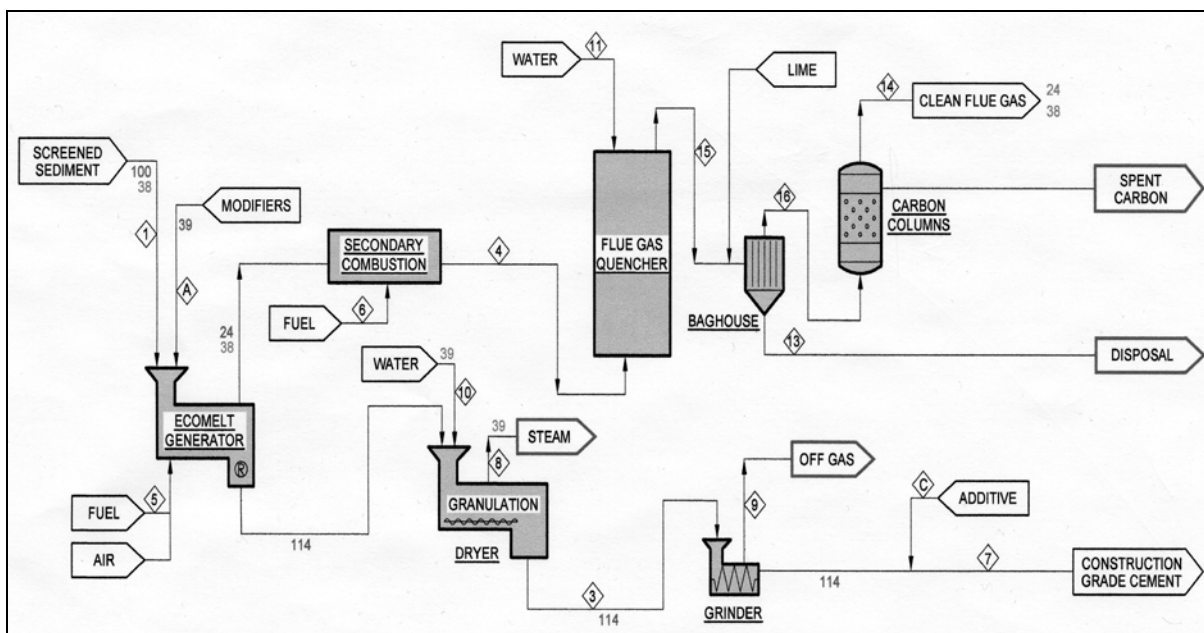

Figure 6. Process flow diagram for Cement-Lock® treatment.

off gases before discharge to the atmosphere. As with the Rotary Kiln, some contaminants may remain leachable at minimal levels in the cement product. Less energy-intensive treatment options may achieve sufficient decontamination in sediments having low contaminant concentrations, although the magnitude of process residuals generated must also be

considered. For example, sediment washing is a low energy process but generates a relatively large wastewater stream, which must be managed.

Engineering considerations

In the Cement-Lock[®] process, a sediment-modifier mixture is charged to a rotary kiln or Ecomelt[®] Generator that is maintained at a temperature of 1,400 to 1,500 °C (2,600 to 2,700 °F) through the combustion of natural gas or other fuels. Nonvolatile heavy metals present in the sediment are immobilized in the melt. The melt is quenched with water, which also granulates the material.

To ensure complete destruction of any residual organic compounds, flue gas from the Ecomelt[®] Generator flows to the secondary combustion chamber (SCC). The flue gas exiting the SCC is rapidly cooled to prevent the formation of dioxin or furan precursors. Powdered lime (CaO) is injected into the cooled gas to capture sulfur oxides and hydrogen chloride. Volatile heavy metals, such as mercury, are removed from the flue gas via a fixed bed of activated carbon or via the injection of powdered activated carbon directly into the flue gas, which could be collected in another bag house. This spent lime mixture and activated carbon must be removed from the flue gas stream, containerized, and disposed of in a proper manner.

Developmental status

The Cement-Lock[®] technology has been applied to the decontamination of dredged sediment in pilot-scale tests using sediment dredged from rivers and harbors of New York and New Jersey. In 1996, a pilot study was conducted by the Institute of Gas Technology and BNL, in which approximately 2.3 m³ (3 yd³) of sediment from Newtown Creek estuary in New York was processed through a Cement-Lock[®] pilot plant (Mensing 2008b).

A Cement-Lock[®] technology pilot test (Phase I) and demonstration test (Phase II) were conducted with dredged sediment collected from the navigational channels of the New York and New Jersey Harbors. Phase I of the pilot test, including planning, construction, permitting and the pilot spanned June 2000 through December 2005. The pilot testing was conducted over the period from December 2003 to March 2005. Approximately 91 mtons (100 tons) of dewatered sediment dredged from the

Stratus Petroleum Refinery Site in upper Newark Bay was treated. However, continuous operations were not possible due to problems with the material feeding and slag discharging components of the demonstration plant (Mensingher 2008a).

In 2006, as part of Phase II, confirmation tests were conducted on Upper Newark Bay sediments. Feed rate of sediment and modifier mix was 860 kg/hour (1,900 lb/hr) and 4.6 mtons (5.1 tons) of Stratus Petroleum sediment and modifiers were processed. An Extended Duration Test was also conducted in Phase II during December 2006 and May 2007 on Passaic River sediments. During the 2006 Extended Duration Test, a total of 15 mtons (16.5 tons) of Passaic River sediment (in situ sediment volume 20 m³ (26 yd³)) were processed through the demonstration plant at rates averaging 680 kg/hr (1,500 lb/hr) sediment. The May 2007 test processed 14 m³ (18 yd³) sediment over 16 hr of processing time. However, during the Extended Duration Test, slag accumulated in the drop-out box and plugged the slag discharge, requiring premature termination of the testing. Total Phase II processing time was less than 48 hr.

The persistence of slag accumulation and challenges associated with balancing throughput and slag management in the kiln would need to be resolved before full-scale implementation of the Cement-Lock[®] process; for example, the drop-out box configuration would need to be redesigned to allow continuous slagging and production of the pozzolanic Ecomelt[®] product. If operated in the non-slagging mode, the material is sintered, not melted, and a construction aggregate or geotechnical fill material called EcoAggMat is produced. Optimized Cement-Lock[®] operations will be configured to produce Ecomelt[®].

Performance

Contaminant fate/treatment mechanisms

Mass balance data for this technology were available from results of the pilot study initiated in 1996, conducted by Institute of Gas Technology and BNL (Mensingher 2008b) and the more recent Passaic River extended duration test detailed in Mensinger (2008a). Mass balance data for the extended duration tests are reviewed in Chapter 3 and Appendix C and provide insight into both incidental loss mechanisms and contaminant mass reduction attributable to treatment processes.

Incidental contaminant reduction and losses

Mass balance calculations were performed on trace metals and organic contaminants from the Cement-Lock® technology Extended Duration Tests in 2007 and 2008. Incidental losses of organic and inorganic contaminants during the Cement-Lock® treatment process can generally be attributed to volatilization or loss of particulates to the off-gas stream.

Results showed that mercury and lead were volatilized during thermal processing. Approximately 60% of the mercury mass and 93% of the lead mass could not be accounted for in the Ecomelt®, granulator vapor, or flue gas. Although the carbon was not analyzed for contaminants due to logistical difficulty in collecting a representative sample, estimates of flue-gas mercury mass before and after the carbon were reduced by 92%, suggesting some of the mercury was sorbed and could have been accounted for had the carbon been analyzed. The difference in lead mass before and after the carbon was 7.4%. The mass balance for other metals, including arsenic, barium, cadmium, silver, and zinc, also suggested a lack of accountability. Some metals may have condensed onto the metal parts of the plant, or become associated with particles that deposited in the system. In addition, due to lead's moderate volatility, some mass likely remained in the high-temperature treatment units, such as the secondary combustion chamber. Some metal mass may have condensed on the powdered lime in the bag house, but samples collected from the bag house were not collected.

For the non-volatile metals chromium and nickel, 38% and 20% of the feed mass was not accounted for in the Ecomelt® and waste streams, respectively. Most of the mass for these metals reported to the Ecomelt® product. The remaining mass is expected to reside in offgas particulate material, which would be captured downstream in the air pollution control equipment. There may be some losses of contaminants to the wastewater stream due to solubilization during dredging and dewatering, but no data were available for these stages of the process.

Treatment mechanisms

Through the Cement-Lock® technology, organic contaminants are treated by thermal decomposition, which occurs in the Ecomelt® Generator and in the secondary combustion chamber. Volatiles, metals, and combustion byproducts passing through the afterburner may be captured in the gas scrubber, particulate collector, and activated carbon bed downstream of

the kiln, reducing losses to the atmosphere. Residual metals are largely immobilized in the product matrix, though some may be slightly leachable under favorable conditions. Some recalcitrant organics may also be leachable, though likely to a lesser degree.

Capacity

Demonstrated capacity. The demonstrated capacity of the Cement-Lock[®] technology includes the 1996 pilot study, in which approximately 2.3 m³ (3 yd³) of sediment from Newtown Creek estuary in New York was processed through a Cement-Lock[®] pilot plant. Approximately 430 kg (940 lb) of Ecomelt[®] product was generated during approximately 40 hr of sediment and modifier feeding. (Mensing 2008b).

Phase I of the Cement-Lock[®] technology pilot test in 2005 treated approximately 91 mtons (100 tons) of dewatered sediment from upper Newark Bay and modifiers were processed through the plant in slagging mode (18 mtons (20 tons)) and non-slagging mode (73 mtons (80 tons)) to produce approximately 1.8 mtons (2.0 tons) of Ecomelt[®] and 48 mtons (53 tons) of EcoAggMat (Ecological Aggregate Material). The plant was operated at a sediment processing rate of 454 kg/hr (1,000 pounds/hr) or (0.4 m³/hour (0.5 yd³/hr)) during both slagging and non-slagging modes. The nominal throughput capacity of this demonstration plant without any process enhancement was estimated to be 7,600 m³/year (10,000 yd³/year) or approximately 1.0 m³/hr (1.3 yd³/hr).

As part of Phase II, confirmation tests were conducted in 2006, in which 4.6 mtons (5.1 tons) of upper Newark Bay sediment-modifier mixture were fed into the demonstration plant at a rate of 454 kg/hr (1,000 lb/hr) or 0.25 m³/hr (0.33 yd³/hr). During the Extended Duration Tests, also conducted in Phase II, a total of 28.7 mtons (31.6 tons) of Passaic River sediment and modifiers, which is equivalent to approximately 34 m³ (44 yd³) of sediment in situ, were processed through the demonstration plant at rates up to 0.8 m³/hr (1 yd³/hr) (Mensing 2008b).

Projected capacity. A commercial scale Cement-Lock[®] module could be sized to treat 96,000 m³/year (125,000 yd³/year); therefore, four or five processing modules would be needed to achieve a treatment capacity of 380,000 m³/year (500,000 yd³/year) for a full-scale Cement-Lock[®] plant (Mensing 2008b).

Efficiency/effectiveness (2006-2007 Phase II Demonstration)

Overall efficiency. Overall process efficiency reflects not only the efficiency of treatment but also the magnitude of all residuals. The mass of total metals, lead, and total PCBs unaccounted for following treatment via the Cement-Lock® technology was 54%, 93%, and 99.9%, respectively. While organic compounds such as PCBs were likely destroyed during thermal treatment, lead and other metals not immobilized in the melt would be expected to be associated with particulates in the offgases. However, particulates from the offgas treatment system were not analyzed and contaminant mass in this process stream could not be evaluated.

Contaminant mass inputs:

- Dewatered sediment (total concentrations)
- Modifiers (total concentrations)
- Granulator quench water (total concentrations)
- Fuel and air for heating (total concentrations)

Contaminant mass outputs:

- Ecomelt® or EcoAggMat product (total or leachable concentrations¹)
- Dryer condensate (total concentrations)
- Particulates captured by emission control (total concentrations)
- Spent activated carbon (total concentrations)
- Flue gas (total concentrations)
- Granulator vapor (total concentrations)
- Ecomelt® Grinder offgas (for commercial plant) (total concentrations)

Stage efficiency. Samples collected from the raw feed to the Ecomelt® generator, samples from residual (total contaminant) and leachable fractions of the quenched Ecomelt® product, and the flue gas between the generator and the carbon column were used to determine the treatment efficiency for the Ecomelt® generator stage of the Cement-Lock® Technology. Contaminant data for particulates lost to the offgases or captured by the bag house were not available; therefore, the stage efficiency calculated here is likely an overestimate.

¹ Using leachable concentrations in the aggregate reflects overall efficiency with respect to all contaminants potentially being released from the process to the environment. For organic contaminants which can be destroyed by the process, using total concentrations to calculate overall efficiency reflects the degree to which the process achieved contaminant destruction and capture.

As shown in Table 7, the stage efficiencies for the Ecomelt® generator based on the above process streams and total concentrations in the Ecomelt® were 60% for mercury, 99.9% for total PCBs, 93% for lead, and 54% for total metals. These values reflect the degree of immobilization of metals and the degree of destruction of organic compounds, but do not account for losses to offgas particulates. Using the TCLP leachable fractions for these efficiencies improved the efficiency substantially for chromium, nickel and total metals, but did not impact mercury, which was largely volatilized or destroyed. The majority of the TCLP analyses were below detection limit for metals, and TCLP analyses were not conducted for PCB or dioxin compounds.

Table 7. Average Ecomelt® generator stage efficiencies for contaminants of concern during extended duration tests with Passaic River sediments.

Analyte	Stage efficiencies (Total analyses-Ecomelt® product)	Stage efficiencies (TCLP leachate-Ecomelt® product)
Total metals ¹	54%	99%
Mercury	60%	60
Lead	93	99.9%
Total PCBs	99.9	NA

¹ Total of As, Ba, Cd, Cr, Co, Cu, Hg, Mn, Ni, Pb, Se, Ag, and Zn

Contaminant mass inputs:

- Solids from drier (total concentrations)
- Modifiers (no data available)
- Fuel and air for heating (no data available)
- Granulator quench water (total concentrations)

Contaminant mass outputs:

- Quenched Ecomelt® or EcoAggMat product (total and TCLP leachable concentrations)
- Flue gas from Ecomelt® generator (total concentrations)
- Granulator vapor (total concentrations)
- Particulates in flue gas from Ecomelt® generator (not available)

Contaminant mass capture efficiencies of the activated carbon bed were also determined for the 2006 and 2007 Extended Duration Tests by taking flue gas samples upstream and downstream of the activated carbon bed.

Average mass capture efficiencies for mercury and total PCBs were 92% and 61%, respectively, while the activated carbon bed was less efficient at capturing total metals, including lead. (PCB capture efficiency by the carbon bed for the December 2006 runs averaged 99% removal; whereas the May 2007 runs demonstrated less than 46% removal.) Lower metals removal efficiencies in the carbon bed may be due to the association of the metals with particulates in the offgas stream, or to the lower affinity of carbon for metals (as compared to organic compounds).

Decontamination efficiency. During the Cement-Lock[®] technology Extended Duration Tests in December 2006 and May 2007, samples of the sediment feed materials and Ecomelt products were collected and analyzed for concentrations of contaminants of concern to determine decontamination efficiencies. The reduction in contaminant mass was estimated by comparing mass in the raw feed to both residual and leachable mass in the quenched Ecomelt[®] product from the granulator. The decontamination efficiencies for various contaminants from these demonstration tests are presented in Table 8. Decontamination efficiencies were greater than 93% for mercury, lead, and total PCBs, while the decontamination efficiency for total metals was 54% based on total concentrations and 99% based on TCLP leachates¹. Concentrations of PAHs in TCLP leachates were all below detection.

Table 8. Decontamination efficiencies for contaminants of concern during extended duration tests with Passaic River sediments.

Analyte	Decontamination efficiencies (Total mass-Ecomelt [®] product)	Decontamination efficiencies (TCLP leachate mass-Ecomelt [®] product)
Total metals ¹	54%	99%
Mercury	99.6%	100%
Lead	93%	100%
Total PCBs	99.99%	NA
1) Total of As, Ba, Cd, Cr, Co, Cu, Hg, Mn, Ni, Pb, Se, Ag, and Zn		

Contaminant extractability. Ecomelt[®] product from the December 2006 Extended Duration Tests was subjected to TCLP and the Synthetic Precipitation Leaching Procedure (SPLP) to determine if Ecomelt[®] samples leached any of the priority metals above regulatory limits. TCLP results were below detection limits for most priority metals and none of

¹ Implies a substantial percentage of the incoming metals were present in the melt, but only a small percentage was leachable.

the Ecomelt® samples leached any priority metals above TCLP regulatory limits. The SPLP results showed that most analyses were below detection limits for priority metals, but one sample exceeded the New Jersey Ground Water Quality Criteria limit for manganese and three exceeded for lead. Similarly, TCLP results from Cement-Lock® cement product produced during the 1996 pilot study using Newtown Creek estuary sediments showed that none of the priority metals leached above TCLP regulatory limits.

Residuals and byproducts

Table 9 summarizes the process residual characteristics and magnitude for the Cement-Lock® technology. Assuming the treated sediment is sufficiently decontaminated to permit unrestricted disposal or beneficial use, the process residuals requiring management include debris removed in the pretreatment step, spent lime-salt-sulfur mixture from the bag house, and spent carbon from the carbon columns downstream of the bag house, all of which would need to be properly disposed.

Based on the 1996 pilot study conducted with sediment from Newtown Creek estuary and the Extended Duration Tests conducted with Passaic River sediments in December 2006 and May 2007, carbon columns may not provide sufficient treatment of the offgases. Flue gas at the activated carbon bed outlet was analyzed for SO₂, NO_x, CO and VOCs. The oxygen concentration in the first test of both the December 2006 and May 2007 sampling was below the 5% level needed to reduce CO emissions, leading to elevated CO emissions during these tests. Nitrogen oxides measurements indicate that NO_x reduction equipment may need to be installed into a commercial-scale Cement-Lock® treatment facility to achieve and maintain lower NO_x emissions.

Beneficial use end product

There are two modes of operation for the Cement-Lock® technology, slagging and non-slagging, each producing a distinct beneficial use product. In slagging mode, the decontaminated dredged sediment is converted into a proprietary product called Ecomelt®, which is pulverized and mixed with either hydrated lime or Portland cement to create a blended cement product. Tests were conducted on a batch of concrete prepared in which Ecomelt® from the Passaic River sediments replaced 40% of the Portland cement normally required (Mensing 2008a, 2008c). Results from compressive strength, drying shrinkage, chloride

Table 9. Cement-Lock® process residuals—character and relative magnitude.

Stage	Residual	Magnitude	Detected Parameters																					
			Metals	PCBs	SVOCs	VOCs	Halogens	Chlorine	Ammonia	Herbicides	Pesticides	SO _x	NO _x	CO	H ² S	PCDDs/PCDFs	TCLP Volatiles	TCLP Semi volatiles	TCLP Metals	MEP Metals	Suspended Particulate	Condensable Particulate	Total Particulate	
Pretreatment	Debris removal	Debris	Screened to <2 in. to remove oversized debris																					
	Dryer	Volatile emissions ⁶	Combined with Ecomelt dryer gases for treatment. Then, those gases are discharged to the atmosphere.																					
		Particulate	Not reported.																					
		Condensate	Not reported. Condensate collected and returned to the Heat Recovery Boilers through a condensate pump.																					
Offgas Treatment	Baghouse	Sediment particulates	X	A	A										X	P	P	P	P				A	
		Volatile emissions ⁶	X ^{2,5}	X	X	X ¹	P		P ³	P ³	P ³	X	X	X ⁴	P	P ³					A	A		
		Spent carbon	A	A	A	A									A	P	P	P	P					
		Volatile emissions & particulates	P ²	X	X	P ³			P ³	P ³				P	X ³						A			

P Potential, if present in sediment
 X Detected at measurable concentrations
 A Assumed to be an operative contaminant loss mechanism
 ND Non detect
 1 Not available for 1996 Pilot Study
 2 Some volatile losses possible if Hg is present
 3 Some volatile losses possible if present
 4 CO emissions were elevated during the first Extended Duration Test Dec 2006 and May 2007 since O₂ concentration was below the 5% level needed to reduce CO emissions
 5 Hg detected at low but measurable concentrations. Pb also detected at measurable concentrations.
 6 The presence of priority air pollutants must be controlled at a commercial-scale facility
 7 This might have been caused by torn or rupture of the bags in the baghouse.

permeability, and elasticity measurements indicated that concrete made with the 40:60 Ecomelt[®]-Portland cement blend is likely to perform favorably in general construction applications (Mensinger 2008a). Specific results from these tests are provided in the mass balance chapter.

Under non-slugging mode, the sediment is converted to EcoAggMat, which can be beneficially used without further treatment, as fill or as a partial replacement for sand in concrete. EcoAggMat was described as coarse grained and lumpy with a low specific gravity (1.85). It can be used as a partial replacement (up to 50% by volume) for sand in mortars based on geotechnical testing reported by Mensinger and Sheng (2006).

Cost

Normalized, exclusive of revenues: \$101.16 (Dec 2009 cost basis)

Normalized, inclusive of estimated revenues \$39.79 (Dec 2009 cost basis)

Mensinger (2008a) conducted an economic evaluation and assessment of processing dredged sediment through a commercial-scale Cement-Lock[®] treatment facility, assuming a capacity to decontaminate 380,000 m³ (500,000 yd³) dredged sediment per year, and produce 220,000 mtons (243,000 tons) of Ecomelt[®] product per year. Cement-Lock[®] is an energy-intensive, high-temperature thermal technology, thus the cost of operation is sensitive to the cost of fuel used. For the economic evaluation conducted by Mensinger, a natural gas cost of \$8.84/million kJ (\$9.33/million Btu) was used, which is based on the average natural gas cost from April 2007 to March 2008. Based on this assumption, and the assumption used for total equipment and installation costs, a break-even tipping fee (the price Cement-Lock[®] must charge to cover the net cost of treatment) of \$52/m³ (\$40/yd³) of dredged sediment was determined. The Ecomelt[®] product was assigned a value of \$94 per mton (\$85 per ton), which is approximately 85% of the cost of Portland cement (\$101 in March 2007). The cost analysis allowed a value for the Ecomelt[®] product and power generation of \$78/m³ (\$60/yd³).

A more thorough cost analysis of the Cement-Lock[®] treatment technology is presented in Chapter 4. The cost analysis in Chapter 4 addresses capital and operational costs needed to carry out all the pre-treatment and treatment activities that may have not been included in the reported costs provided by Mensinger (2008a), and provides a comparison of the costs

associated with the Cement-Lock® treatment technology and the other technologies. Based on that analysis, a net unit cost of \$132/m³ (\$101/yd³) (Dec 2009 basis) was estimated for the Cement-Lock® process exclusive of revenues from beneficial use product and \$52/m³ (\$40/yd³) (Dec 2009 basis) , inclusive of revenues from sale of beneficial use product.

Technology references/reports

Mensingher, M. C. 2008a. *Sediment Decontamination Demonstration Program - Cement-Lock® Technology, Final Report: Phase II Demonstration Tests with Straus Petroleum and Passaic River Sediments.*

Mensingher, M. C. 2008b. *Cement-Lock® Technology for Decontaminating Dredged Estuarine Sediments, Final Project Report.* GTI Project Number 15372.

Mensingher, M. C. 2008c. *Cement-Lock® Technology for Decontaminating Dredged Estuarine Sediments, Topical Report on Beneficial Use of Ecomelt® from Passaic River Sediment at Montclair State University, New Jersey.*

Mensingher, M. C., and T. R. Sheng. 2006. *Demonstration Program: Cement-Lock® Technology Phase I Pilot Test. Final Report.* Submitted to New Jersey Department of Transportation, Office of Maritime Resources. Trenton, NJ.

Technology points of contact

Mr. Michael C. Mensinger
Gas Technology Institute
1700 South Mount Prospect Road
Des Plaines, IL 60018
847-768-0602

mike.mensingher@gastechnology.org

Commercializing company

Mr. Al Hendricks
Volcano Partners, LLC
557 North Wymore Road
Suite 100
Maitland, FL 32751
407-492-9731
jmtwah@aol.com

Minergy glass furnace technology (GFT) brief

Synopsis

Minergy's glass furnace technology (GFT) is a vitrification process developed for the treatment of sediments contaminated with heavy metals and/or organic compounds. After thermal drying to remove most of the water in the sediment, the solids are melted at high temperature (1600°C (2900°F)) in a refractory-lined melter (Figure 7) producing a glass aggregate and effectively encapsulating metals and destroying organic contaminants.

Flux materials are added to control melt temperatures and improve the qualities of the molten glass. The molten glass is quenched to produce a glass aggregate, which is reportedly suitable for beneficial uses such as hot mix asphalt, construction fill, cement substitute, and ceramic floor tiles. Additional size reduction and classification may be required to meet some reuse specifications. Emission controls to remove particulates, sulfur and nitrogen oxides, and residual contaminants from the flue gases are an essential part of the process.

Applicability

The Minergy GFT technology, like other thermal technologies, should be effective for treatment of most metals and organics, including PCBs and PAHs, at a wide range of contaminant concentrations. As a vitrification technology, GFT forms glass by melting silica in the feed material. Most sediments have mineralogical characteristics suitable for this purpose. The Fox River sediment used for a pilot demonstration of this technology contained 60 to 80 percent silt with lesser amounts of sand and clay (0 to 40 percent each) (USEPA 2004).

Although vitrification has been tested on estuarine sediment, salinity may be a limiting factor due to corrosive effects of sodium chloride volatilized during the melting process, and potential for salt deposits in the off-gas system. McLaughlin et al. (1999) recommend removing salt (85% removal for sediment from Newtown Creek, NY) from saline sediment by washing



Figure 7. Pilot-scale glass furnace (USEPA 2004)

prior to vitrification, but the practicality of this is site-specific. Because the thermal technologies require a very dry feed, any water introduced to the sediment will subsequently have to be removed, and effective dilution of pore water will require large volumes of fresh water. Sequential pore water exchange on a filter press is another alternative that requires less water and could be done as an integral part of the dewatering process. However, an extended contact time is required to allow diffusion of salt from sediment pores, and the pore water may need to be exchanged several times to remove all residual salt. To operate as a pseudo-continuous flow process, equipment redundancy (multiple presses in parallel) would also be required and would be quite costly.

Engineering considerations

The pre-treatment and proprietary stages of the Minergy process are described in Table 10 and illustrated in Figures 8 and 9. The pretreatment stages will consist of equipment to remove both large and small debris and to dry and condition the material for the process. Metallic debris, such as nuts and bolts, is of particular concern and may need to be removed magnetically (USEPA 2004). Moisture content of the feed going to the dryer must not exceed 50%. Dredged material will need to be screened and, if slurried, dewatered to meet these requirements. In addition, material blending may be required to improve workability of the wet sediment, to optimize mineral composition of the feed, and to control temperatures during the process.

The core Minergy process consists of a melter adapted for the application from existing glass furnace technology, quench tank, off-gas collection/treatment system, and associated material handling equipment (Table 10 and Figure 9). Numbered process streams in Figure 9 represent streams for which contaminant data was available to support the mass balance. Sediment enters the dryer at a maximum 50% moisture content (M.C.), where it is further dried at 180 °C (356 °F) and discharged at an M.C. less than 10 percent. The dried sediment is then conveyed to the melter, which is fueled with oxygen and natural gas.

Table 10. Minergy glass furnace technology process stages.

Stage		Function
Non-Proprietary Stages	Grizzly (or comparable)	Removal of oversize materials and debris
	Screen and filter press (or comparable)	Fine debris removal, sand separation, and mechanical dewatering of fines
	Dryer	Thermal water content reduction of melter feed
	Blending equipment	Addition of dried sediment to optimize water content and improve handling characteristics.
Proprietary Stages	Glass Furnace (refractory-lined rectangular melter)	Contaminant volatilization, thermal decomposition of organic compounds, immobilization of metals in melt. (Flux is added to the charger for the melter.)
	Quench Tank	Cooling the melt
	Screw Conveyor	Extract and de-water the frit glass from the quench tank
	Grinder	Size reduction of melt
	Gas Cooling Section, Wet Scrubber, Particulate Control, Carbon Filter	Collection of particulates from offgases, and capture of fugitive contaminants

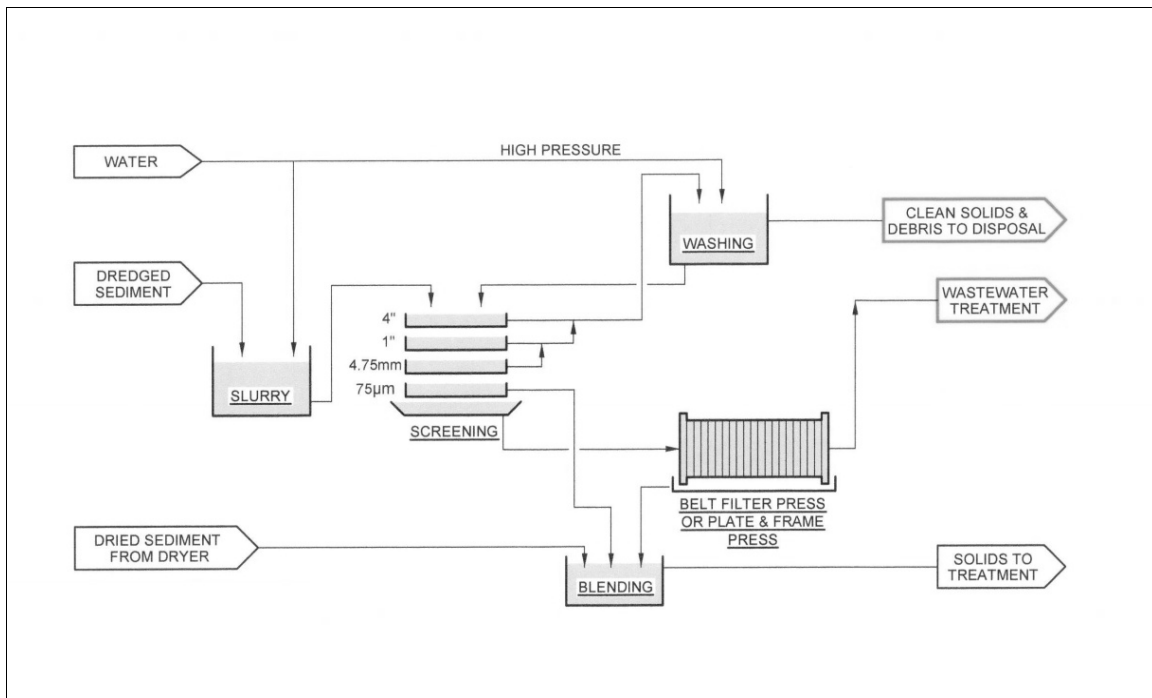

Figure 8. Pretreatment processes for glass furnace technology.

Developmental status

Minergy GFT is relatively mature, having been adapted from a similar process being used at full scale for the recycling of paper mill wastewater solids and sewage sludge. The glass furnace is commonly used for glass manufacturing, and the supporting unit processes for materials handling and emission controls are well-developed industrial processes. A full-scale plant constructed for treatment of wastewater solids generated by paper mills became operational in January 1998 (www.Minergy.com). However, full-scale sediment treatment by the Minergy GFT process or other vitrification processes has not been demonstrated as of this writing.

Pilot demonstration. The GFT was demonstrated at pilot scale under the SITE program in 2001 (USEPA 2004). For the pilot test, 64 mtons (70 tons) (roughly 50 m³ (70 yd³)) of mechanically dewatered sediment were set aside during dredging in the Fox River. The test consisted of separate dryer and melter tests. The dryer pilot test used a Holoflite[®] dryer, with an approximate capacity of 6.4 kg/hr (14 lbs/hr) wet sediment. Drying for the pilot scale melt was performed in a drum oven with a capacity of twelve 0.21-m³ (55-gal) drums. The pilot glass furnace melter accommodated a feed rate of 91 kg/hr (200 lb/hr) dried sediment.

Performance

Contaminant fate/treatment mechanisms

Mass balance data for the Fox River Pilot Demonstration reported by the USEPA SITE program (USEPA 2004) indicated that both incidental loss mechanisms and contaminant mass reduction and immobilization mechanisms were attributable to the GFT process. The mass balance is reviewed in more detail in Chapter 3.

Incidental contaminant reduction and losses

Contaminants may be lost in the pre-treatment steps for the GFT. Because all process streams were not characterized by mass and concentration during the pilot scale demonstration, the magnitude of these losses cannot be estimated reliably. Some soluble contaminants would be expected to be lost in the filtrate from the belt filter press used to dewater the river sediment prior to drying and processing. The gases produced by the thermal drying step will also release volatile contaminants from the sediment as well as some contaminated particulates. These losses can be controlled by water

treatment and offgas treatment, such as by integrating the dryer emissions with the flue gas control system for the melter. Flue gases from the melter are treated to condense volatile metals, to capture particulates, to scrub combustion by-products, and to adsorb residual hydrocarbons and metals. These processes are effective, but a small fraction of the contaminants will escape the off-gas treatment system. Particulates captured from the off-gas stream could be fed back through the system as an alternative to separate disposal.

Treatment mechanisms

The GFT reduces the toxicity of the dredged-and-dewatered sediment by destroying organic contaminants and incorporating hazardous, inorganic constituents into a glass matrix, resistant to leaching. The glass furnace destroys organic contaminants by heating to 1600°C (2900°F) in the presence of oxygen; thereby oxidizing the organic materials. Inorganic materials, and some residual organic compounds, are bound into the molten glass and retained after cooling and solidifying. An almost three-fold volume reduction of sediment to glass aggregate was observed during the SITE demonstration (USEPA 2004).

Capacity

Demonstrated capacity - The GFT demonstrated at pilot scale under the SITE program in 2001 (USEPA 2004) treated 64 mtons (70 tons) of mechanically dewatered material at a processing rate of 91 kg/hr (200 lb/hr).

Projected capacity - While a large-scale operation would not likely be mobile due to the weight of the equipment, the GFT is scalable through the use of appropriately sized melters or multiple units in parallel. Minergy has developed estimated processing costs for plants with capacity ranging from 220-1600 mtons (240-1800 tons)/day dredged and dewatered sediment (91-680 mtons (100-750 tons)/day glass aggregate production).

Effectiveness/efficiency

The demonstration report (USEPA 2004) for the Minergy SITE demonstration included estimates of process efficiency for various contaminants. These estimates were calculated by subtracting the output concentration from the input concentration and dividing by the input

concentration. However, to provide an equivalent basis for technology comparisons, process efficiencies consistent with the definitions provided in the section titled “Mass balance-challenges and limitations” were calculated as part of the analysis presented in this document. The following represents the independent efficiency evaluation conducted for this report, using data contained in the demonstration reports, and reconstructed materials and contaminant mass balances. Overall and Stage efficiencies were defined in the section titled “Efficiency/Effectiveness.

Overall efficiency. Overall efficiency is defined in Equation 1 presented earlier in this chapter. For the Minergy process, the following data are needed to calculate overall efficiency.

Contaminant mass inputs:

- Dewatered sediment, usually a filter cake (total concentrations)
- Flux material (total concentrations)
- Scrubber water (total concentrations)
- Quench water (total concentrations)
- Fuel and air for direct heating (total concentrations)

Contaminant mass outputs:

- Glass aggregate (leachable concentrations)
- Dryer condensate (total concentrations)
- Dryer dust (total concentrations)
- Particulates captured by emission control (total concentrations)
- Scrubber liquor blowdown (total concentrations)
- Spent activated carbon (total concentrations)
- Flue gas (total concentrations)
- Quench water exchange (total concentrations)

Overall efficiency for the pre-treatment and treatment steps could not be determined because the dryer dust and condensate were not sampled during the Fox River demonstration. However, the overall efficiency beginning with the treatment part of the process train could be assessed. Based on the mass balance detailed in Chapter 3, the glass furnace technology demonstrated an overall efficiency of 99.998% for total PCBs, the primary contaminant of concern. The metals arsenic, barium, cadmium, chromium, mercury, lead, and selenium were detected in the

feed to the melter, but barium, chromium, lead and selenium were the only metals found above detection limits in the glass aggregate, and all metals and PCBs were below detection in glass aggregate leachates prepared by the American Society for Testing and Materials (ASTM) Standard Test Method for Shake Extraction of Solid Waste with Water (D3987-99) (ASTM 1999) and by the Synthetic Precipitate Leaching Procedure (SPLP) (EPA Method 1312) (USEPA 1996). Trace amounts of the metals (except for selenium) were found in the cooling tower water. The overall efficiency ranged from minus 270% for barium to 99% for arsenic, cadmium, and mercury (assuming a value of 0 where all replicate analyses for a sampling point are below the detection limit).

Stage efficiency—melter. Efficiency of the melter was calculated based on the streams entering and exiting the melter.

Contaminant mass inputs:

- Solids from drier (total concentrations)
- Flux material (total concentrations)
- Fuel and air for direct heating (total concentrations)

Contaminant mass outputs:

- Glass aggregate (leachable concentrations)
- Flue gas from melter (total concentrations)
- Quench water exchange (total concentrations)

The melter stage efficiency for PCBs is the same as the overall efficiency value (99.998%). The leachate metal concentrations were below detection, as well as the analyses for the flue gas from the melter and the quench tank water (except for barium); therefore, the stage efficiency for metals based on leachable concentration (except barium) was 100%. Stage efficiency for barium was 98.5%. The stage efficiency based on total concentrations for metals was negative for barium, chromium, and selenium (indicating more mass was measured in the outgoing process streams than in the incoming streams) and ranged from 80 to 100% for arsenic, cadmium, mercury, and lead.

Stage efficiency—dryer. Efficiency of the pretreatment drying step for the Fox River sediment was determined in a separate drying test using a Holoflite® disk dryer.

Contaminant mass inputs:

- Wet (after belt filter press) sediment (total concentrations)

Contaminant mass outputs:

- Dried sediment (total concentrations)
- Dryer condensate (total concentrations)
- Dryer dust (total concentrations)

The dryer efficiency calculation for PCBs yielded a 22% decrease in PCB mass during the drying process (based on the Minergy drying data). The metal mass balance for the dryer (based on the Hazen drying data) showed metal masses in the dried sediment within +/- 20% of the input.

Decontamination efficiency. The reduction in contaminant mass in the sediment solids was estimated by comparing input mass for each contaminant to the residual and leachable contaminant mass for the aggregate. Based on residual mass, the PCB decontamination efficiency for the glass aggregate product was 99.9986%. Metals decontamination efficiency was 100% for arsenic, cadmium, and mercury because these metals were reported as below detection in aggregate or leachates. Decontamination efficiency for lead was 80%. Since metals can be immobilized, but not destroyed, metals mass unaccounted for was thought attributable to either losses in the waste streams, deposits on the walls of the equipment, or material variability. The mass of barium was 2.6 times greater in the aggregate than in the sediment feed and chromium mass was 31% higher in the system output, which was attributed to material variability.

Contaminant extractability. Contaminant extractability was determined using the Synthetic Precipitate Leaching Procedure (SPLP) and American Society of Testing and Materials (ASTM) water leach analyses performed on glass aggregate. PCB and metal analytes were below the analyte detection limit for both tests (USEPA 2004). Crushed aggregate subjected to leaching analysis also indicated no contaminants are expected to leach

from the glass material over time. However, companion leach tests for the sediment or melter feed were not available for comparison, nor were there data for the more aggressive TCLP test.

Residuals and byproducts

Residuals from this process include coarse debris removed upstream of the dewatering process and metallic debris removed upstream of the kiln, wastewater from the mechanical dewatering process, condensate from the thermal drying operation, cooling and scrubbing blowdown wastewater, particulate matter collected on the flue gas filters, spent activated carbon, and quench water discharges. These streams will require treatment, disposal or permitted discharge. Interstate Technology and Regulatory Council (2005) and Brandon and Price (2007) provide risk-based screening values that may be appropriate for comparison to the process residuals. As discussed in the section titled "Residuals treatment requirements," the physical characteristics of the residuals should be factored into the environmental suitability determination.

Table 11 presents process residuals in terms of their character and relative magnitude. Dioxins (PCDDs) and furans (PCDFs) are recognized byproducts of combustion processes. Pre- and post-dryer sediment, off-gases and condensate were analyzed for PCDDs and PCDFs. Data for dryer air samples were given as a mass rather than a concentration and reportedly were unreliable due to contamination of the off-gas stream with dust. PCDDs and PCDFs were found at measurable concentrations in the dried feed sediment and in flue gases. All but two post-carbon treatment flue gas samples were non-detect, indicating these compounds were effectively removed in the carbon filter. Analyses for the highly toxic 2,3,7,8-TCDD in the flue gas and the post-carbon gas were less than the detection limit (0.002-0.012 ng/dscm). PCDDs and PCDFs were measured in process-generated dust and in some glass aggregate SPLP leachate samples. These data indicate that PCDDs and PCDFs were present in the sediment prior to treatment, and that they were still present (generally at lower concentrations) after treatment. Whether the presence of these compounds following treatment is a result of persistence or generation during processing by the transformation of PCBs cannot be determined from the information available.

Table 11. Glass Furnace Technology process residuals—character and relative magnitude.

Stage	Residual	Magnitude	Detected Parameters																				
			Metals	PCBs	SVOCs	VOCs	Halogens	Ammonia	Herbicides	Pesticides	SO _x	NO _x	CO	H ₂ S	PCDDs/PCDFs	TCLP Volatiles	TCLP Semi volatiles	TCLP Metals	MEP Metals	Suspended Particulate	Condensable Particulate	Total Particulate	
Pretreatment	Debris removal	Debris	Not reported																				
		Wash water	P	P	P	P	P	P	P	P					P					P			
	Dewatering	Filtrate	P	P	P	P	P	P	P	P					P					P			
		Volatile emissions	P ²	P ³	P ³	P ³			P ³	P ³	P ³			P	P ³								
	Dryer	Volatile emissions	See SITE report for concentrations by contaminant																				
Off-gas particulate		A	A	A																X	A	A	
Condensate		X	X	X										X ⁴						A			
Kiln	Quench tank	Wastewater	X ¹	X	X										P					A			
		Volatile emissions	P ²	P ³	P ³	P ³			P ³														
Offgas Treatment	Baghouse/ Ceramic filter catch	Sediment particulates	X	A	A					P ³					X	P	P	P	P				
	Scrubber	Wastewater ⁷ (blowdown)	X ⁶	X	A															A			
		Volatile emissions ⁵	P ²	X	X	P ³	P		P ³	P ³	P ³	A	A	A	P	P ³					A	A	A
		Spent carbon	A	A	A	A								A	P	P	P	P					

P Potential, if present in sediment
 X Detected at measurable concentrations
 A Assumed to be an operative contaminant loss mechanism
 ND Non detect
 1 Only Ba was detected at measurable concentrations
 2 Some volatile losses possible if Hg is present
 3 Some volatile losses possible if present
 4 PCDDs and PCDFs were present in the sediment prior to treatment
 5 Post carbon gas
 6 Se and Ag were non detect
 7 Contaminants were expected to be more concentrated after the second run because the system was configured as a recirculating loop and expected to be more diluted after the fourth and sixth run because the system was configured with fresh water.

Beneficial use end product

The glass aggregate is potentially usable for construction fill, roadbed construction, concrete additives, blended cements, asphalt paving, blasting grit, ceramic floor tiles, and asphalt shingle granules. Bulk density, iron oxide concentration, crystal silica content, calcium oxide, hardness, and particle size are common criteria for several uses. More detailed information on the properties of the product is included in Chapter 3.

Cost

Normalized, exclusive of revenues: \$71.75 (Dec 2009 cost basis)

Normalized, inclusive of estimated revenues \$70.84 (Dec 2009 cost basis)

An estimated unit cost of approximately \$51/m³ (\$39/yd³) (+50 percent - 30 percent accuracy) (USEPA 2004) was developed based on the outcome of the SITE pilot demonstration. This cost was based on the following assumptions: 24 hr per day, 350 days per year operation, over a 15-year project period, with a total project volume of 1.14 to 8.57 million mtons (1.26 to 9.45 million tons) of contaminated sediment over the life of the project. No market recovery for the product was assumed. The estimated unit cost of \$51/m³ (\$39/yd³) represents just the thermal processing costs. Material pretreatment, wastewater treatment, land acquisition, site prep, mobilization, demobilization, and site restoration were costs not included. Energy costs were based on prevailing rates at the time of the analysis, and would be expected to be higher now. According to the vendor (USEPA 2004), " areas where scale-up economies could be realized include the potential lower energy costs per ton of sediment treated, reduced sampling and analysis once treatment efficiencies have been established, and automation of some processes."

Technology references/reports

McLaughlin, D. F., S. V. Dighe, D. L. Keairns, and N. H. Ulerich. 1999. Decontamination and beneficial use of dredged estuarine sediment: The Westinghouse plasma vitrification process. Presented at 19th Western Dredging Association (WEDA XIX) Annual Meeting and Conference and 31st Texas A&M University Dredging Seminar (TAMU 31). Louisville, Kentucky. May 15-20, 1999. (PDF file).

¹ 2003 year cost basis

Minergy Corporation. 2002. Final report sediment melter demonstration project. Prepared for Wisconsin Department of Natural Resources. Madison, Wisconsin.

Minergy Corporation. 2003. Supplemental sediment handling characterization report—Glass furnace technology. Prepared for Wisconsin Department of Natural Resources. Madison, Wisconsin.

U.S. Environmental Protection Agency (USEPA). 2004. Minergy Corporation glass furnace technology evaluation--Innovative technology evaluation report. Office of Research and Development, National Risk Management Research Laboratory. Cincinnati, OH.

Technology points of contact

Minergy Corporation¹
21900 Marylee St.
#252
Woodland Hills, CA 91367
Craig Cameron
818-401-5255

Minergy Corporation
1512 S. Commercial St.
Neenah, WI 54956
(920) 727-1919
E-mail: info@minergy.com

BioGenesisSM Sediment Washing Technology brief

Synopsis

The BioGenesisSM Sediment Washing Technology is a proprietary process that uses impact forces inside a collision chamber to strip contaminants from the surface of sediment particles, and a physical-chemical oxidation process to oxidize organic chemicals (Figure 10). The goal of the BioGenesisSM technology is to strip contaminants and naturally occurring organic material (biofilm)



Figure 10. BioGenesisSM commercial scale, Keasby, NJ (Stern et al. 2009)

¹ Wisconsin Electric recently sold Minergy to this private owner. The GFT demonstration project described in this report was performed by Wisconsin Electric.

from the surface of the solid particles. Contaminants sorbed to the individual, fine-grained solid particles and the biomass stripped from solid particles are transferred to the aqueous phase and removed the wastewater treatment step. The remaining solids may be used beneficially as a component for the manufacture of top soil. The cavitation /oxidation unit process is intended to contribute to the destruction of organic contaminants and biomass segregated from the sediment particles. Hydrogen peroxide, an oxidizing agent, is added to the sediment slurry upstream of the cavitation system. Cavitation occurs when air bubbles created in the slurry implode. According to BioGenesis Enterprises, Inc., the implosion created by cavitation enhances the ability of the oxidizing agent to break down organic molecules into carbon dioxide and water.

Applicability

The BioGenesisSM Sediment Washing Technology is an ambient temperature sediment treatment process, applicable to a range of contaminants and contaminant concentrations. The reduction of contaminant concentrations in the treated sediment is dependent on operating conditions, type of contaminant, initial sediment contaminant concentrations, and sediment properties. A continuous water supply is required; however, water is recycled within the process to reduce the volume of fresh water needed. High contaminant concentrations may require multiple processing steps to achieve the desired level of contaminant reduction. Table 12 summarizes the treatment steps making up the BioGenesisSM technology.

Engineering considerations

This technology is designed to disaggregate particles and remove sorbed contaminants and organic matter from sediment solids. Particle separation processes separate the larger particles from the smaller particles.¹ Organic materials and organic contaminants associated with the fine fraction are treated using chemical-physical oxidation processes. The primary treatment processes consist of particle separation, followed by cavitation and chemical oxidation, and dewatering of coarse and fine fractions, and blending of treated coarse materials and fines (Figures 11 and 12).

¹ The coarse fraction of sediment is often assumed to be less contaminated than the fine fraction. Where a coarse organic fraction is present, or where the coarse fraction particulates are coated with organics or oil and grease, this may not be true. This issue is given further treatment in discussion of the Passaic River sediment testing for this technology.

Table 12. BioGenesisSM process stages.

Stage		Function
Non-Proprietary Stages	Grizzly (or comparable)	Removal of oversized material
	Vibrating screen	Separation and removal of debris and coarse material (6.4 mm (>0.25 in.))
Proprietary Stages	Pre-processor (BioGenesis SM chemical (surfactant) addition and mixing)	Disaggregate sediment particles and outer layer of contaminants
	Aeration, flotation, and skimming	Float and remove lighter organics
	Collision chamber (sediment washer)	Apply high pressure impact technology to remove adsorbed contaminants from sediment particles and transfer into water phase
	Oxidant addition, mixing, and cavitation/oxidation	Oxidize desorbed organic contaminants under (localized) increased temperature and pressure
	Hydrocyclone/dewatering screen	Solid-liquid separation to collect treated coarse grained product
	Filter press and/or centrifuge	Dewater treated sediment for beneficial use
	Water treatment	Remove contaminants from centrate/filtrate

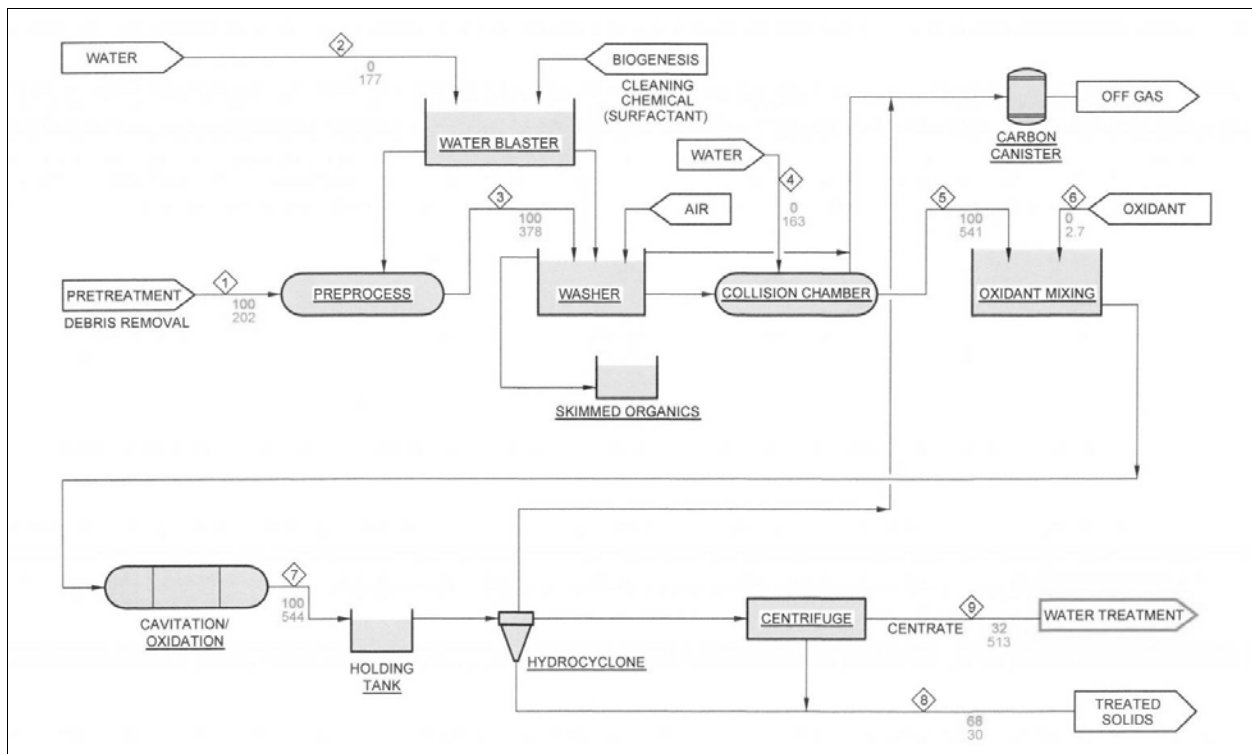

Figure 11. Process flow diagram for BioGenesisSM sediment washing-NYNJH Project.

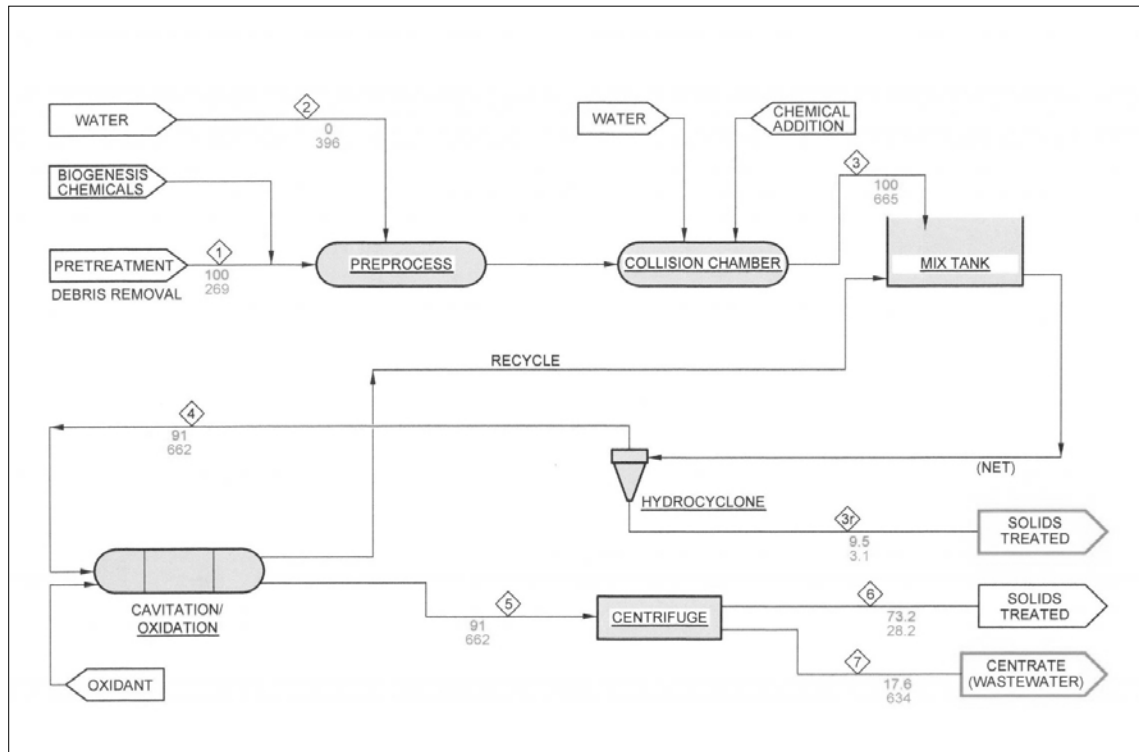

Figure 12. Process flow diagram for BioGenesisSM sediment washing-Venice Project.

A continuous water supply is needed for the preprocessing and collision chamber stages, where surfactants, chelating agents, and defoamers may be added and high pressure water jets are used to break apart sediment particles and strip organic material from the sediment particles. The volume of fresh water is reduced by recycling liquid streams within the process.

Wastewater generated by the process will contain solubilized metals and floatable organic materials with varying levels of associated contaminants. This is potentially a relatively large waste stream that may require appropriate onsite storage, treatment, and permitted disposal. Depending on the specific contaminants and concentrations present, disposal in an industrial sewer may be a possibility. Disposal to a surface water body will likely require additional treatment of the wastewater in order to assure water quality criteria will be met.¹

¹ The most recent (2006) configuration for the BioGenesisSM process includes wastewater treatment as an integral component of the technology.

Solid residuals resulting from this technology, including debris from screening facility and sludge from wastewater treatment, will require disposal and onsite storage until disposal.

Developmental status

The BioGenesisSM Sediment Washing Technology has undergone bench scale and pilot scale testing using contaminated sediments from various sources. Under the WRDA Sediment Decontamination Demonstration Program and Brookhaven National Laboratory (BNL), the BioGenesisSM Sediment Washing Technology underwent testing at a New York/New Jersey Harbor site. During the Phase 1 pilot testing, 500 m³ (700 yd³) of dredged material was used from the Stratus Petroleum Corporation – Newark Terminal Site located in Newark, New Jersey on the upper Newark Bay, lower Passaic River (BioGenesis and Weston 1999). The purpose of the pilot demonstration project was to evaluate the effectiveness of the BioGenesisSM Sediment Washing Technology and to collect design data for scale-up activities.

A pilot demonstration of the BioGenesisSM Sediment Washing Technology was conducted in Venice, Italy, in the winter of 2003-2004 (Biogenesis Italia, LLC, et al. 2005). During this demonstration project, approximately 330 m³ (430 yd³) of sediment were dredged from the canals in Porto Marghera, Venice, Italy, and transported in four separate batches to the pilot site. The sediment was treated in a series of pilot test runs on each batch, and the reduction in metals and organics concentrations were measured.

In 2006, a full-scale demonstration test of sediment treatment using the BioGenesisSM Sediment Washing Technology was conducted on sediment dredged from the lower Passaic River (Biogenesis Washing BGW, LLC, and MWH Americas, Inc. 2009). The process flow changed somewhat from earlier configurations as seen in Figure 13. Additions to the process included new grain size separation and dewatering operations, as well as a wastewater treatment system. Approximately 11,000 m³ (15,000 yd³) of dredged sediment was treated at a demonstration facility in Keasbey, NJ. Processing rate for this demonstration was 31 m³/hr (40 yd³/hr) or 190,000 m³ (250,000 yd³/year). The purpose of this demonstration project was to determine the effectiveness of the decontamination process and collect engineering data needed for a full-scale design of a sediment treatment facility. Bench testing was also conducted in conjunction with

this demonstration to evaluate process modifications to improve removal efficiencies for PAHs. Results from this demonstration project are discussed in this report. However, information to prepare or review a mass balance for this demonstration was not reported, limiting analysis by the approach suggested by this report.

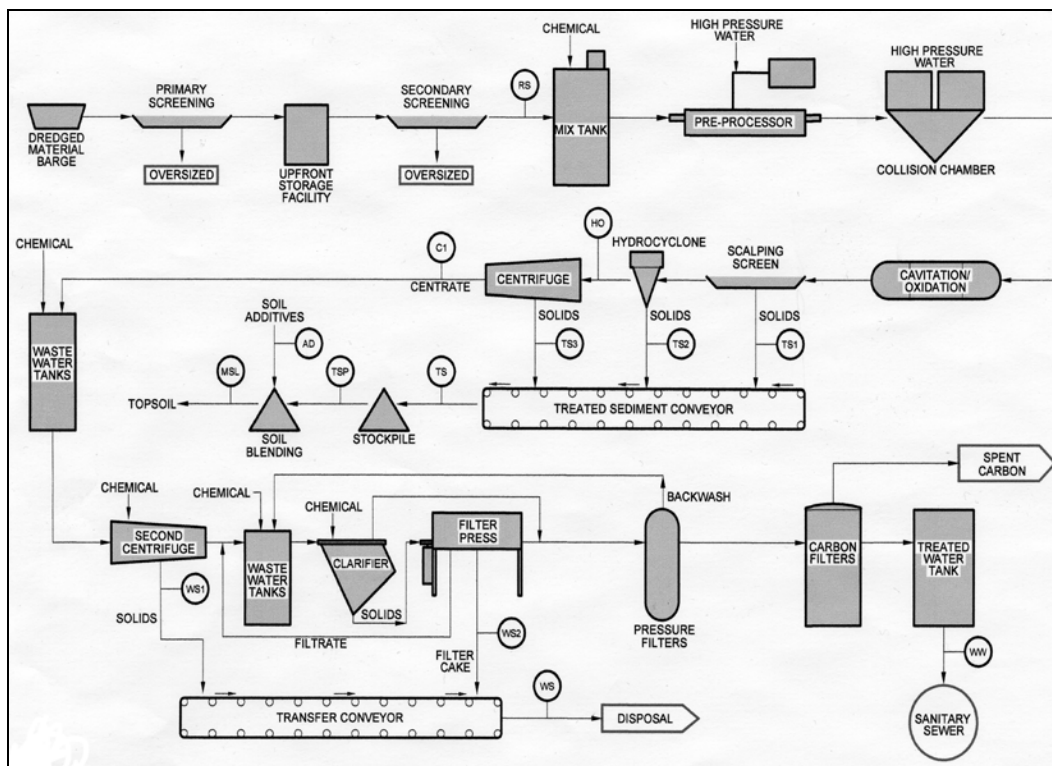

Figure 13. Process flow diagram for Biogenesis® 2006 demonstration-Keasby, NJ (Biogenesis Washing BGW, et al. 2009).

A bench scale treatability test on soil and sediment samples from the Housatonic River—Rest-of-River site was conducted in fall 2007 to evaluate the removal of PCBs from the contaminated river sediment using BioGenesisSM. Sediment samples were collected from three river locations representing a range of physical characteristics (fine grain, coarse grain, and soil). The bench-scale equipment was designed to perform tests on a limited volume of material (typically 1.1×10^{-2} to 1.9×10^{-2} m³ (3 to 5 gal) for each run. Three validation test runs were conducted on the three sediment types to evaluate the effects of multiple treatment cycles on PCB concentrations, where treated solids from the liquid/solid separation step were recombined and processed two additional times (Biogenesis 2008).

Performance

Contaminant fate/treatment mechanisms

Mass balance data for the New York/New Jersey Harbor (NYNJH) and Venice pilot demonstrations using the BioGenesisSM Sediment Washing Technology (Biogenesis Italia, LLC, et al. 2005, BioGenesis Enterprises, Inc., and Roy F. Weston, Inc. 1999) demonstrate contaminant mass reduction attributable to both incidental loss mechanisms and treatment processes. Mass balance calculations performed for the NYNJH pilot tests results and the Venice pilot, are presented in Appendices E and F, respectively.

Incidental contaminant reduction and losses

Incidental losses identified for this process would be largely associated with contaminant and material losses in the pretreatment stages and volatilization at various stages of the process. Contaminants solubilized to post-processing wastewater represent one of the intended contaminant reduction mechanisms and would not be considered incidental losses.

Mass balance calculations performed on the NYNJH pilot test results show differences between the mass of the divalent metals in the untreated sediments and the combined mass of metals in the centrate and treated sediments was typically less than 10%, suggesting a relatively low incidental loss for divalent metals.

Mercury is much more volatile than most divalent metals, and can volatilize in organic (i.e., methylated) or inorganic states, but cannot be destroyed by oxidation. Only 60% of the mercury inlet mass was measured in the liquid and solid outlets, suggesting that a portion of the mercury mass was likely volatilized during the treatment process. Only 57% and 49% of the benzo[a]pyrene mass and fluoranthene inlet mass was recovered in the outlet, but this could be attributable to either incidental loss through volatilization or to physico-chemical oxidation. However, because most of the PAH losses occurred in the pretreatment step for oil and grease removal, PAH removal is attributed primarily to the pretreatment process, not the cavitation/oxidation process.

Treatment mechanisms

The BioGenesisSM Soil/Sediment Washing Technology employs multiple treatment processes to achieve particle separation and contaminant removal and destruction. Metals treatment is accomplished by phase transfer from the solid phase to the aqueous phase and loss of some metals contaminated particulates to the wastewater stream. Organic contaminants may also be solubilized to some extent and transferred to the aqueous phase, or oxidized through the physico-chemical oxidation processes in the system. The solid and liquid phases are then separated, at which point the wastewater can either be recycled through the system or undergo treatment for disposal.

Capacity

Demonstrated capacity. At the NYNJH site, 500 m³ (700 yd³) of dredged material was used for the pilot demonstration of the BioGenesisSM Sediment Washing Technology. Trial runs to establish operating parameters for individual components of the process consumed approximately 440 m³ (580 yd³) of material. The validation runs for this demonstration treated four batches of approximately 5.6 m³ (7.3 yd³) each at a rate of 28 m³/hr (36 yd³/hr). During the pilot testing conducted in Venice in Italy approximately 330 m³ (430 yd³) of sediment was collected and the pilot test was conducted at process flow rates ranging from 13–20 m³/hr (17–26 yd³/hr). The NJ full-scale demonstration project treated 30 m³/hr (40 yd³/hr) or 190,000 m³/year (250,000 yd³/year).

Projected capacity. Future phases of the NYNJH pilot project include the application of the BioGenesisSM Treatment Technology to sediment decontamination on 190,000 m³/year (250,000 yd³/year) of dredged material from the NY/NJ Harbor, with the ultimate goal of a commercial-scale facility capable of decontaminating 380,000 m³ (500,000 yd³) of dredged material per year.

Based on the results from the Venice pilot demonstration project, the treatment process was scaled up to a full-scale conceptual design, which assumed a design criteria process flow rate of 34 m³/hr (45 yd³/hr) sediment at 32% dry solids.

Efficiency/effectiveness

Overall efficiency. Overall process efficiency reflects the efficiency of treatment and also the magnitude of all residuals. This efficiency is calculated with Equation 1 presented earlier.

Contaminant mass inputs:

- Dredged sediment feed (total concentrations)
- Process water additions at preprocessor, collision chamber, and cavitation/oxidation unit (total concentrations)
- BioGenesisSM chemicals (total concentrations)

Contaminant mass outputs:

- Coarse-grained hydrocyclone underflow (total concentrations)
- Centrifuge solids (total concentrations)
- Centrifuge wastewater or centrate (total concentrations)
- Off-gases (total concentrations)
- Spent carbon used for emission control (total concentrations)

Overall efficiencies calculated for the NYNJH project are presented in Table 13. Since the overall efficiency takes into account all of the residual streams and the process basically separates the metals into liquid and solids fractions, a total accounting of the metals mass would yield 0% overall efficiency based on total (digested) concentrations. About 13% of the mass for the aggregated metals list was lost in the process—a reasonably good closure for the mass balance. However, 40% of the mercury was lost during processing. The overall efficiency for the organics ranged from 53 to 79% where contaminant classes were summed. The efficiency for the two individual PAHs listed were in the same range. Data for off-gases and spent carbon were not available to discount losses due to vaporization.

Table 14 summarizes mass balance efficiencies for four sediments investigated for the Venice pilot project. Overall efficiencies range from negative percentages, indicating that there was more contaminant in the output mass than in the input mass, to 66%. Batch 4 showed increased mass for all the contaminants. The project report (Biogenesis Italia, LLC, et al. 2005) suggested that residual sediment built up in the equipment was not completely removed by the cleaning procedure employed after each batch.

Table 13. Mass balance efficiencies for BioGenesisSM NYNJH pilot study.

Contaminant	Overall efficiency	Decontamination efficiency	Fraction of input in centrifuge solids	Fraction of input in centrate (total and dissolved)
Chromium ¹	11.3%	82.3%	17.7%	71.0%
Lead ¹	4.7%	73.7	26.3	69.0
Nickel ¹	-8.2%	52.9%	47.1%	61.0%
Zinc ¹	22.5%	71.3%	28.6%	48.9%
Mercury ¹	39.8%	95.4%	4.6%	55.6%
Benzo(a)pyrene	54.5%	54.5%	45.5%	0.0%
Fluoranthene	51.0%	69.5%	30.5%	18.5%
Total Metals	12.7%	75.0%	25.0%	62.2%
Total PAHs	61.2%	66.3%	33.7%	5.1%
Total PCBs (Homologues)	53.4%	99.8%	0.2%	46.4%
Total Dioxins/Furans	78.9%	99.9%	0.1%	21.0%

¹ Metals concentrations in sediment feed met New Jersey criteria and were not targeted for treatment in this study.

Stage efficiency

Stage efficiencies were calculated around each of the four major operations for the NYNJH pilot —preprocessor, collision chamber, cavitation/oxidation unit, and centrifuge. Calculated efficiencies for selected contaminants are shown in Table 15. A more thorough description of contaminated reduction following each BioGenesisSM treatment step is provided in Chapter 3, Mass Balance Evaluations.

Results from the 1999 NYNJH pilot study indicate that total metals mass is initially reduced during the pre-processing phase, tends to increase following the collision chamber, but then is reduced following the cavitation/oxidation process and increases during the final liquid/solid separation step. The increase in metals at various steps is difficult to explain, but may be attributable to material variability or perhaps to liberation of metals from the primary minerals due to decomposition of the particulates, although the latter seems unlikely in the absence of aggressive acids. For metals, most of the reduction is associated with a redistribution of metal mass, with some incidental volatilization. As a result, the metals are concentrated in the centrate solids following

Table 14. Mass balance efficiencies for BioGenesisSM Venice pilot demonstration.

Contaminant	Overall efficiency	Decontamination efficiency	Fraction of input in centrifuge solids	Fraction of input in centrate (solid)	Fraction of input in centrate (dissolved)
Batch 1: PC4					
Chromium	1.4%	43%	54.9%	40.5%	1.1%
Copper	22.8%	74%	25.2%	50.9%	0.3%
Lead	5.7%	68%	30.6%	10.9%	51.6%
Mercury	-10.9%	63%	35.5%	70.9%	3.5%
Nickel	-46.4%	-3%	101.6%	37.6%	5.8%
Zinc	-14.8%	36%	61.1%	7.7%	43.5%
Total PAHs	32.0%	36%	63.4%	3.8%	0.1%
Batch 2: PC2					
Chromium	10.2%	67%	32.5%	56.5%	0.2%
Copper	16.5%	69%	30.0%	52.6%	0.2%
Lead	11.5%	78%	21.0%	32.2%	34.2%
Mercury	7.3%	65%	34.8%	57.6%	0.0%
Nickel	-0.8%	56%	42.7%	48.2%	8.8%
Zinc	-29.7%	73%	26.1%	66.3%	36.3%
Total PAHs	49.9%	51%	48.4%	1.0%	0.2%
Batch 3: PC3					
Chromium	-42.1%	5%	91.6%	46.9%	0.0%
Copper	66.3%	86%	13.4%	19.8%	0.0%
Lead	9.8%	63%	35.9%	15.1%	37.9%
Mercury	21.8%	47%	51.9%	25.5%	0.0%
Nickel	-86.4%	-43%	137.1%	33.4%	10.4%
Zinc	-179.0%	-118%	208.3%	5.8%	55.7%
Total PAHs	47.4%	49%	50.3%	1.9%	0.0%
Batch 4: PC1					
Chromium	-219.0%	-26%	114.6%	192.4%	0.9%
Copper	-171.7%	47%	48.3%	217.9%	0.8%
Lead	-1097.0%	-97%	182.4%	621.3%	378.7%
Mercury	-164.1%	43%	55.2%	207.4%	0.0%
Nickel	-238.6%	-33%	118.3%	173.7%	31.7%
Zinc	-710.9%	-178%	253.5%	233.8%	298.6%
Total PAHs	-71.5%	-25%	123.8%	46.3%	0.0%

Table 15. Stage efficiencies for BioGenesisSM unit processes during NYNJH pilot study.

Contaminant	Preprocessor efficiency	Collision chamber efficiency	Cavitation/oxidation efficiency	Centrifuge efficiency
Chromium	35.2%	-46.3%	37.0%	-48.4%
Lead	28.4%	-31.5%	32.0%	-48.9%
Nickel	-0.8%	-15.5%	16.8%	-11.7%
Zinc	24.6%	-27.8%	21.6%	-2.5%
Mercury	28.9%	-5.8%	30.0%	-14.3%
Benzo(a)pyrene	35.6%	-23.4%	8.6%	37.4%
Fluoranthene	52.1%	-21.8%	4.0%	12.6%
Total Metals	29.8%	-37.4%	28.5%	-26.5%
Total PAHs	49.9%	-16.8%	3.7%	31.0%
Total PCBs (A1254 + A1260)	35.7%	-61.6%	1.0%	-19.8%

treatment. Results from the 1999 NYNJH study show that for PAH compounds, almost all of the contaminant concentration reductions occur in the pre-processor stage, rather than in the cavitation/oxidation unit.

Efficiencies at each stage of the Venice project could not be calculated because contaminants were not analyzed at each stage. The contaminant mass was available for the hydrocyclone underflow. The discussion in Chapter 3 shows that generally less than 5% of the contaminant mass reported to the coarse material removed by the hydrocyclone. The contaminant mass in the centrifuge solids, the centrate solids, and the centrate dissolved fraction is shown for each contaminant in Table 15. These data show that the output contaminant mass is split between the centrifuge cake and the liquids released from the centrifuge. A relatively small fraction of the centrate contaminant mass is dissolved in the centrate. For PAHs, most of the output mass remained in the centrifuge solids.

Decontamination efficiency. The treatment efficiency of the BioGenesisSM Sediment Washing Technology for various contaminants of concern is dependent on a variety of conditions, including initial sediment contaminant concentrations, sediment properties such as grain size distribution and total organic carbon content, and operating conditions of the process equipment, such as chemical addition rates. Decontamination efficiencies for the NYNJH pilot were calculated for various contaminants

based on the mass balance in Appendix E and are shown in Table 13. These efficiencies represent the contaminant mass in the feed material removed by the process when compared to the contaminant mass in the centrifuge solids or cake. It does not include the contaminant mass transferred to the liquid phase by the process, nor the solids in the centrate. The relatively high percentages—ranging from 53 to 95% for metals and 54 to 99.9% for organics—suggest the overall process effected some treatment of the sediment feed material.

Decontamination efficiency data were also collected for the Venice pilot project by measuring contaminant mass in the raw untreated sediment, the treated sediment from the hydrocyclone, which served to remove coarser material (sand and fine sand) prior to cavitation/oxidation, and treated sediment from the centrifuge, which typically consisted of silt and some clay. Decontamination efficiencies are listed in Table 14. Efficiencies observed for metals were as high as 86%. The decontamination efficiencies for batches 1, 2, and 3 ranged from 36 to 59% for PAHs.

Contaminant extractability

Dredged material from the New York/New Jersey Harbor site was stabilized with Portland cement to meet structural fill requirements and sampled using the Multiple Extraction Procedure (MEP) to determine if concrete samples leached any contaminants above regulatory limits. MEP results showed extractions of organic compounds, including semivolatile organics, pesticides, PCBs, furans, and dioxins, were typically below detection limits. MEP results for priority metals were also generally below detection limits, and the stabilized sediment sample typically did not leach any priority metals above New Jersey Ground Water Quality Criteria. However, cement stabilization is not part of the proprietary procedure, and may have been equally effective without the proprietary sediment washing steps. The leachability of stabilized materials also cannot be taken to be representative of the leachability of treated materials without this additional step. The value of this testing in terms of process evaluation is therefore questionable.

During the New Jersey Full-Scale Demonstration Project, decontaminated sediment from the Lower Passaic River was used to manufacture topsoil for placement at Montclair State University. The manufactured topsoil was tested using the Toxicity Characteristic Leaching Procedure and results indicated the topsoil would not leach the residual inorganic contaminants

above regulatory levels.¹ Although this is likely more representative of the leaching behavior of the treated sediment than the TCLP results from the cement-stabilized sediment, in the absence of testing of the treated, but unamended, sediment, it is not possible to assess what the leaching behavior would be as a result of the treatment alone.

Residuals and byproducts

Process residuals are summarized in Table 16. Assuming wastewater produced as part of the pretreatment step can be recycled to slurry the sediment, process residuals requiring management will include debris removed from the sediment during pretreatment, wastewater sludge, and the wastewater generated from the final liquid/solid separation step. At least part of the wastewater can be reused in the facility. Given that phase transfer is the principal mechanism of metals removal from the sediment, and the lack of clear evidence of the efficacy of the oxidation unit, the centrate wastewater stream can be expected to be concentrated in solubilized metals and possibly organic contaminants, as well as fine solids. Some level of treatment is expected to be necessary before the wastewater could be discharged to a receiving water body as a permitted discharge. Additional treatment required before discharge to a wastewater treatment facility will depend on the quality of the wastewater and the specific facility requirements. Some onsite storage may be required in order to manage both the debris and wastewater process streams.

The 1999 NYNJH pilot demonstration generated approximately 1128 m³ (298,000 gal) of wastewater (approximately 2.1 m³ wastewater/m³ sediment treated), which was disposed at Passaic Valley Sewerage Commission facilities. Solids content of the centrate was approximately 6%.

Based on the full-scale conceptual design criteria for the Venice facility (Biogenesis Italia, LLC, et al. 2005), for a process flow rate of 34 m³/hr (45 yd³/hr) of sediment, approximately 47.6 m³/hr of wastewater was assumed to be generated (300,000 gal per day, or a ratio of approximately 1.4 m³ wastewater/m³ sediment).

¹ Personal Communication. April 23, 2010. John Sontag, Vice President, Director of Engineering, Biogenesis Enterprises, West Chester, PA.

Table 16. BioGenesisSM process residuals—character and relative magnitude.

Stage	Residual	Magnitude	Detected Parameters																				
			Metals	PCBs	SVOCs	VOCs	Halogens	Chlorine	Ammonia	Herbicides	Pesticides	SO _x	NO _x	CO	H ² S	PCDDs/PCDFs	TCLP Volatiles	TCLP Semi volatiles	TCLP Metals	MEP Metals	Suspended Particulate	Condensable Particulate	Total Particulate
Pre-treatment	Debris Removal	Oversize debris	Screened to 1/4" to remove oversized debris. The volume of oversized debris was very small.																				
		Coarse solids (>0.25 in.)	Not reported																				
		Wash water	P	P	P	P	P		P	P	P					P					P		
Collision Chamber	Carbon Cannister	Off-gases	P ²	P ³	P ³	P ³				P ³	P ³	P ³			P	P ³							
		Spent carbon	A	A	A	A										A	P	P	P	P			
Dewatering	Centrifuge	Solids	X ^{1,2}	X ⁴	P ¹	P ¹										P	P	P	P	P			
		Centrate	X ^{1,2}				X	X	X			X	X									X	

P Potential, if present in sediment
 X Detected at measurable concentrations
 A Assumed to be an operative contaminant loss mechanism
 ND Non detect
 1 Possible if open tank configuration as depicted in process flow diagrams
 2 Some volatile losses possible if Hg is present
 3 Some volatile losses possible if present
 4 PCBs were only analyzed on Batch 3.

Beneficial use end product

The BioGenesisSM Sediment Washing Technology process is designed to produce an end product that can be applied towards construction fill, building blocks, landfill cover material, or brownfields redevelopment. For the full-scale demonstration, decontaminated sediment was combined with organic material to form a manufactured soil. Depending on compliance with necessary (federal, state, or local) standards, manufactured soil may be used for landscaping along highways, industrial parks, or for residential areas. Although revenue from the sale of topsoil could be used to offset the dredging and decontamination fees, the greater cost advantage is likely achieved through reduced transport and disposal requirements. The specific use of the end product from this technology may vary based on site-specific treatment efficiency and environmental regulations.

Whether treatment achievable with the BioGenesisSM technology is sufficient to meet beneficial use requirements will depend in part on the starting concentrations of the sediment and the requirements for the specific application. In New York State, for example, the cleanup objective for beneficial use of soils requires PCB concentrations less than 1 mg/g for restricted residential or commercial uses, 25 mg/kg for restricted industrial uses, and 0.1 mg/kg for unrestricted use (New York State Department of Environmental Conservation 2006). Achieving these standards on the basis of the 60-90% removal decontamination efficiencies reported in Table 14 limits the range of potential starting concentrations and depends on the nature of the source sediment (i.e., particle size distribution, water content, and organic carbon content). Subsequent testing of a proposed process modification targeting removal of PCBs suggests higher decontamination efficiencies for organic contaminants may be attainable, but this process modification has only been tested at bench scale to date. This testing is discussed in more detail in Chapter 3 (Housatonic Rest of the River Bench Study).

Cost^{1,2}

Normalized, exclusive of revenues: \$51.99/yd³ (Dec 2009 cost basis)

Normalized, inclusive of estimated revenues – \$40.69/yd³

¹ Costs referenced to December 31, 2004 in report.

² Year cost basis not specified, but assumed to be 2009 based on the date of publication of the report.

As part of the pilot scale project in Venice, Italy, a cost estimate for a full-scale plant was developed, assuming a process flow rate of approximately 31 m³/hr (40 yd³/hr). The planning-level cost was estimated to be \$80/m³ (\$61 / yd³) (Biogenesis Italia, LLC, et al. 2005).

More comprehensive unit costs including capital, overhead, and operating costs were provided for the most recent demonstration (BioGenesis Washing BGW, LLC, and MHW Americas, Inc. 2009) and ranged from \$77/m³ (\$59/yd³) for a 31 m³/hr (40 yd³/hr) facility, and \$67/m³ (\$51/yd³) for a 61 m³/hr (80 yd³/hr) facility (BioGenesis Washing BGW, LLC, and MHW Americas, Inc. 2009). These costs “represent a total “tipping cost” for the decontamination and beneficial use of dredged material, from the offloading of the sediment from the delivery barges to the marketing and beneficial use of the manufactured soil,” but did not assume a value for revenues generated from the sale of the material (BioGenesis Washing BGW, LLC, and MHW Americas, Inc. 2009). Biogenesis¹ provided an estimated net value for manufactured soil product from the 2006 demonstration \$11.30/yd³ sediment. These estimates are consistent with the normalized costs developed in Chapter 4, Technology references, and reports.

BioGenesis. 2008. BioGenesisSM Sediment Washing Technology Bench-Scale, Treatability Study Report, Housatonic River-Rest-of-River Site. March.

BioGenesis Enterprises, Inc., and Roy F. Weston, Inc. 1999. BioGenesisSM Sediment Washing Technology Full-Scale, 40 yd³/Hour Sediment Decontamination Facility For the NY/NJ Harbor, Final Report On The Pilot Demonstration Project, December 1999, Submitted to Brookhaven National Laboratory Under BNL Contract No. 725044.

BioGenesis Italia, LLC, MHW Americas, Inc., and Jan de Nul, NV. 2005. Pilot Scale Demonstration Project of the BioGenesisSM Sediment Decontamination Process, Autorità Portuale di Venezia, Porto Marghera, Venice, Italy. Springfield, VA.

Stern, Eric A., Keith W. Jones, W. Scott Douglas, Huan E. Feng, Nicolas L. Clesceri. 2009. “New York/New Jersey Ex Situ Sediment Decontamination Program (1994-2008).” *Remediation of Contaminated Sediments—2009. Proceedings of the Fifth International Conference on Remediation of Contaminated Sediments* (Jacksonville, Florida; February 2–5, 2009). G.S. Durell and E.A. Foote (Conference Chairs), Battelle Memorial Institute, Columbus, OH.
www.battelle.org/sedimentscon

¹ Personal Communication. August 23, 2010. John Sontag, Jr., Vice President, Director of Engineering, Biogenesis Enterprises, Inc., West Chester, PA.

BioGenesis Washing BGW, LLC, and MHW Americas, Inc. 2009. Demonstration Testing
And Full-Scale Operation Of The BiogenesisSM Sediment Decontamination
Process, Keasby, NJ. Springfield, VA.

Technology point of contact

Mr. John Sontag, Jr.
BioGenesis Enterprises, Inc.
1390 Beau Drive
Westchester, PA 19380
610-436-6393

3 Mass Balance Evaluations

JCI/Upcycle Rotary Kiln mass balance

Operational description

The integrated treatment process consists of two distinct phases: (i) pretreatment, consisting of size reduction (through solid separation) and dewatering of the raw feed, and (ii) treatment (kiln) phase. In the pretreatment phase, debris and solids larger than 1.3 cm (0.5 in.) (gravel, and cobbles) are removed and the sand and fine sediment fraction dewatered. For illustrative purposes, a non-proprietary solid separation and mechanical dewatering treatment train is depicted in Figure 3, although the technology that was demonstrated included proprietary components.

After dewatering, filter cake and shale are dried and ground, then blended. Water is added to optimize moisture content and the blend is then extruded as pelleted feed for the kiln.

The major components of the pilot rotary kiln system are shown in Figure 4, and include a feed mechanism, a rotary kiln with integrated product cooler, and an air pollution control system comprised of an afterburner, a ceramic filter collector, and a recirculating wet scrubber. Off-gases from the dryer are passed through a baghouse to capture particulates. In the demonstration, there was no thermal treatment or capture of contaminants from the dryer off-gases, but at full scale it is expected that all off-gas particulate and contaminant capture would be combined into one pollution control system.

In Figure 4, process streams for which contaminant mass data were available are numbered, and correspond to column headings in the complete mass balance summary provided in Appendix B. Table 17 summarizes the process streams as stage inputs and outputs, and indicates which samples were analyzed for a given contaminant. This summary table is intended to provide sources of the information for ready reference, show how sampling varied from one demonstration to another (where there have been multiple demonstrations), what process streams were (or were not) accounted for, and illustrate any inconsistencies in chemical analysis that complicated mass balance reconstruction.

Table 17. Sampling and testing matrix for Rotary Kiln treatment stages and process streams⁶ (continued)

Parameters	Dewatering					Dryer				Baghouse			Extruder			
	In		Out			In		Out		In	Out		In			Out
	Raw Dredged Sediment ⁶	Water	Dewatered fines (<75um)	Filtrate (to disposal)	Dewatered coarse and debris	Dewatered Fines	Natural Gas/Supplemental Fuel	Dried Sediment	Offgases	Dryer Offgases	Particulates	Offgases (gas phase)	Dried Sediment	Shale	Water	Extruded pellets
Percent moisture	X															
Percent solids	X															
Particle size distribution	X															
Condensable particulate																
Suspended particulate																
Total suspended solids				X												
Total particulate								X	X ¹							
Contaminant concentration																
TCLP results																X ²
MEP results																
TOC	X			X									X			
Metals	X		X	X									X		X	
Mercury	X		X	X				X		X			X		X	
PCBs	X		X												X	
SVOCs	X		X	X											X	
VOCS	X			X				X							X	

Table 17. (Continued)

Halogens														X		X
Dioxins/Furans	X		X	X					X			X				X
Pesticides	X		X	X												X
Herbicides	X															X
Total hydrocarbons												X				
NO _x									X			X				
SO ₂									X			X				
CO									X			X				
Cl ₂																
Ammonia																
Cyanide	X															
Parameters	Rotary Kiln				Afterburner				Particulate Collector			Scrubber				
	In		Out		In		Out		In	Out		In		Out		
	Extruded pellets	Fuel	Air	Light Weight Aggregate	Offgases	Offgases	Fuel	Combusted Offgases	Combusted Offgases	Ceramic Filter Catch (particulates)	Offgases (gas phase)	Offgases (gas phase)	Water	Lime	Offgases (Gas Phase)	Scrubber Liquor (Wastewater)
Percent moisture																
Percent solids																
Particle size distribution																
Condensable particulate					X	X ¹					X	X			X	
Suspended particulate											X	X			X	

Table 17. (Concluded)

Total suspended solids																	
Total particulate										X	X				X		
Contaminant concentration																	
TCLP results	X ²			X ³						X ²							
MEP results				X ⁴						X							
TOC										X							
Metals	X			X	X ⁵	X ⁵				X	X ⁵	X ⁵	X		X ⁵	X	
Mercury	X			X						X	X	X	X		X	X	
PCBs	X			X	X	X				X	X	X			X		
SVOCs	X			X	X	X				X	X	X			X		
VOCS	X			X	X	X				X	X	X			X		
Halogens	X	X		X	X	X					X	X	X		X	X	
Dioxins/Furans	X			X	X	X				X	X	X			X		
Pesticides	X			X						X							
Herbicides	X			X						X							
Total hydrocarbons					X	X									X		
NO _x					X	X					X	X			X		
SO ₂					X	X					X	X			X		
CO					X	X					X	X			X		
Cl ₂					X	X					X	X			X		
Ammonia					X	X					X	X			X		
Cyanide																	
¹ Grey text indicates an input stream that is the same as the preceding output stream ² Volatiles and semi-volatiles ³ Volatiles, semi-volatiles and metals, including mercury ⁴ Metals, including mercury ⁵ Including CrVI ⁶ JCI/Upcycle (2002)																	

Mass balance

The purpose of the mass balance evaluation is to determine the fate of the contaminants in each stage of the process in order to:

- Determine where and by what mechanisms treatment is occurring
- Evaluate the adequacy of the data in providing a complete accounting of contaminant fate
- Verify reported process performance
- Estimate the magnitude of process residuals

In the rotary kiln demonstration, roughly 2.2 m³ (3 yd³) of as-dredged sediment was prepared for processing in the kiln. Samples were taken from solid, liquid and gas phase process streams at various points in the system and analyzed for properties and constituents listed in Table 17. Discrete grab samples were taken of fuel oil, shale, scrubber makeup water and scrubber liquor, and composite samples were taken of ceramic filter catch and aggregate product.

Material flow through the system was reconstructed based on reported feed rates and other information. Where multiple samples were taken for a process stream, the average concentration was used in reconstructing the contaminant mass balance. Complete mass balance tables are included in Appendix A.

Materials mass balance

Pre-treatment - Approximately 2,950 kg (6,504 lb) of filter cake at 57% moisture content plus 18,000 gal of water were produced by the dewatering process. The production of 68 m³ (18,000 gal) of water resulted from adding dilution water to the as dredged sediment to facilitate screening out debris greater than 13 mm (0.5 in.) and optimizing the water content for feed to the belt filter press. Based on optimization studies during the pilot study, a solids concentration of 5 to 10 percent solids in the filter press feed was projected to produce a filter cake with 55% solids. The filter cake produced for feeding to the kiln was reported as 43% solids by weight (JCI/Ucycle Associates, LLC 2002).

Treatment - Figure 14 illustrates the relative mass of solids and water entering and leaving the treatment system in the 2001 demonstration. (Note: this graph represents only external process streams for which

materials mass balance data were reported.) Solids and water lost from the dryer stage and from the kiln stage reflect vapor and particulates lost to the off-gases. The figures reflect that approximately 15% of the dewatered solids coming into the dryer are lost to the off-gases, the feed circuit, and handling. Also lost are 10% of the pelleted solids coming into the kiln, primarily due to ignition of organic matter. These values can be used to approximate the magnitude of solid residuals produced for a given treatment volume. The addition of shale prior to extrusion increased the mass of the solids going to the kiln by 38%, contributing to the reduction in contaminant concentration of the processed sediment (by dilution). In this case, the addition of shale reduced contaminant concentrations in the feed by approximately 30% prior to treatment in the kiln. Contaminant mass going to the kiln would not be affected unless the shale contains some incidental contaminants, however. These factors illustrate the importance of documenting the movement of contaminant and material mass throughout the process such that the mechanisms of contaminant reduction and implications with respect to residuals production are understood.

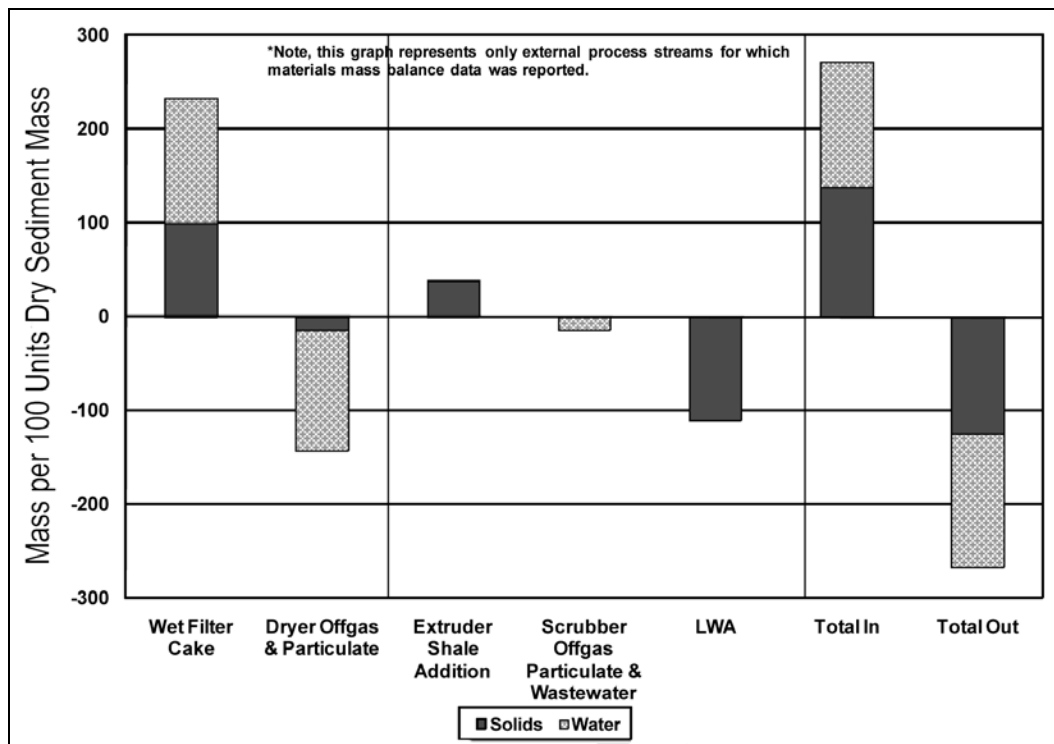

Figure 14. Rotary kiln materials mass balance based on 100 units dry sediment solids treated.

Contaminant mass balance

Pre-treatment – Available data for the pre-treatment phase is insufficient to fully account for fate of contaminants in this stage of the process. Contaminant loss with oversized materials is largely associated with the sediment coating these materials, for example, but perhaps could be quantified through capture and analysis of sediments and water generated from the debris washing process. JCI/Upcycle Associates, LLC (2002) reported very small amounts (less than 19 L (5 gal)) of debris retained on the 13-mm (0.5-in.) screen for the 3 m³ (4 yd³) of material treated. Any contaminant loss at this stage could be attributable to solubilization, solids losses, material variation, or volatilization.

Based on contaminant concentrations measured in dredged sediment, dewatered filter cake and filtrate, it appears that on average less than 1% of the metals were lost to solubilization in the dewatering phase, with a maximum of 3.76% (magnesium). Almost 40% of the mercury is unaccounted for in this stage of the process, suggesting significant volatile losses here. For the remaining metals, from 2 to 27% of the mass was unaccounted for, with five metals having greater mass observed in the filtrate and filter cake than in the dredged sediment. Loss of volatile contaminants would be expected to occur through normal handling and pre-treatment processes and would be difficult to quantify unless the off-gas stream was monitored.

Treatment - Overall, mass unaccounted for may be attributable to contaminant destruction, losses through volatilization or solubilization, immobilization in the product, material and analytical variability, and unsampled or unanalyzed process streams. Chances of closing the mass balance are best where all process streams have been sampled and analyzed for the same constituents, but material variability and analytical limitations will still complicate data interpretation.

Metals are most easily followed through the process. Leachable concentrations can be determined through TCLP extractions or other established leach test protocols and total concentrations through acid digestion of solids, including the produced aggregate. Organics concentrations, however, must be determined using a form of extraction and essentially represent a leachable rather than total concentrations where the analysis of the aggregate is concerned. The aggregate can be ground, providing more contact area available to the solvents used for

organics extraction, but there is really no way to measure all of the residual organics imbedded in the aggregated particulates themselves; their fate must be inferred by coupling what is known about the contaminant properties with what is known about the removal mechanisms based on the available data.

The resulting contaminant mass balance is illustrated for selected parameters in Figures 15-18. For the entire process (taking into account all input and output streams as previously described in Chapter 2), total metals mass unaccounted for in the mass balance ranged from approximately 30% (nickel) to 82% (silver) (based on total metals mass). Based on the lesser of total or extractable metals mass, metals mass unaccounted for ranged from 64% (mercury) to 88% (potassium). For the PAHs, with the exception of bis(2-ethylhexyl)phthalate, mass unaccounted for ranged from 75% to 85% and was presumed destroyed. For the PCBs, 84% of the mass was unaccounted for in the output streams and presumed destroyed. For dioxins and furans, from 84 to 85% of incoming contaminant mass in the filter cake was unaccounted for and presumed destroyed. Approximately 15% of all contaminants lost from the system are associated with the assumed particle loss from the dryer.

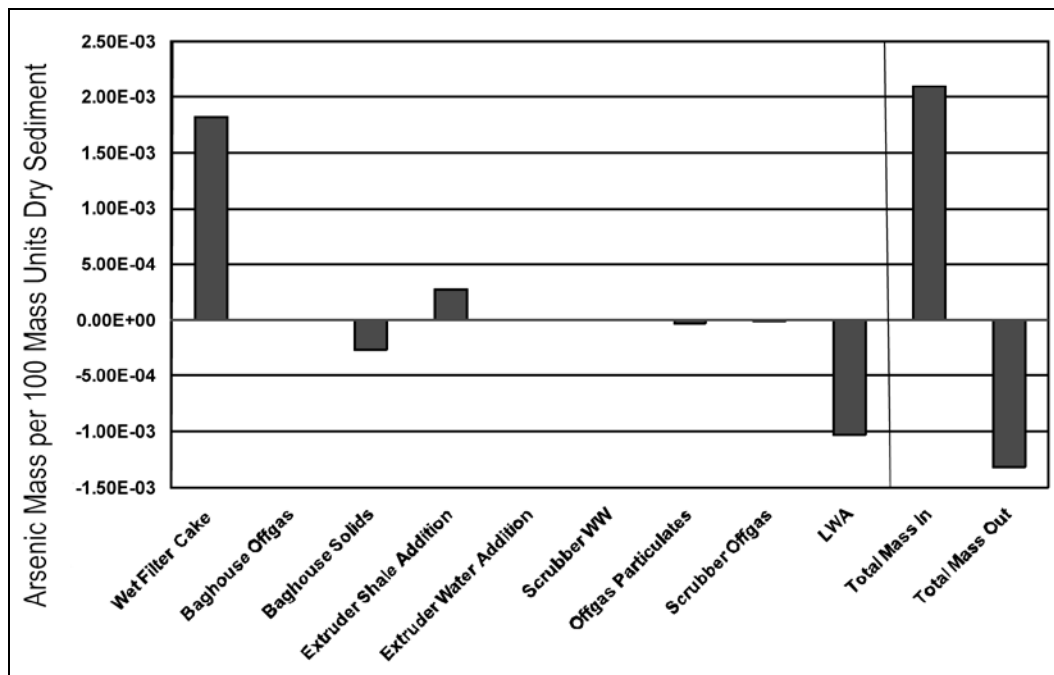

Figure 15. Fate of arsenic in rotary kiln (total mass basis).

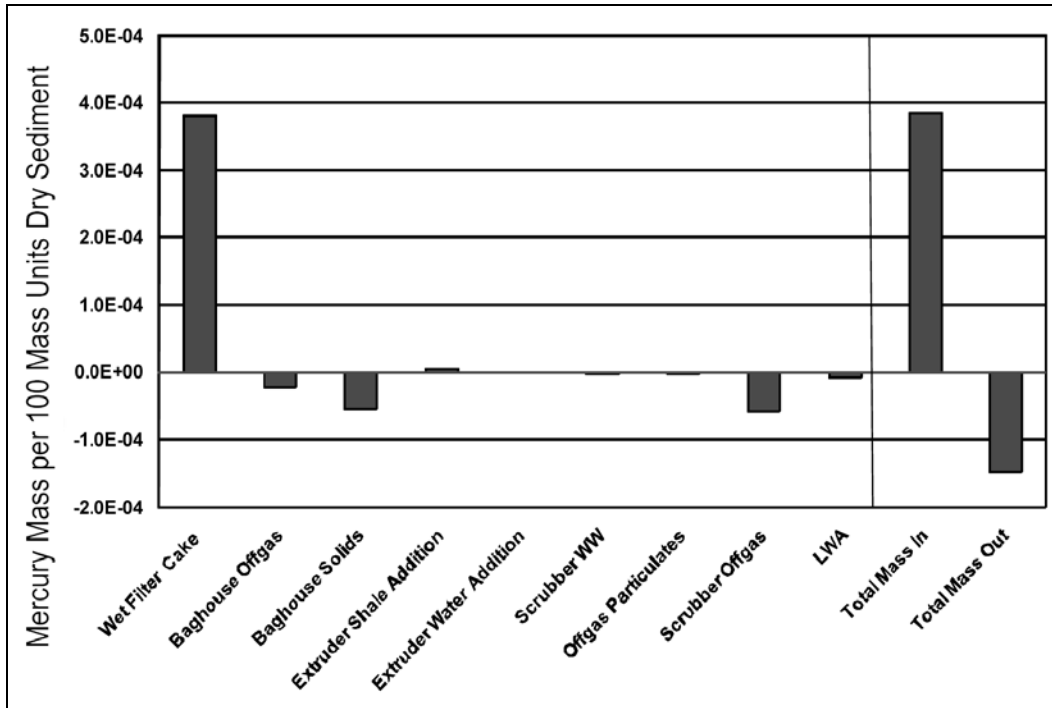

Figure 16. Fate of mercury in rotary kiln (total mass basis).

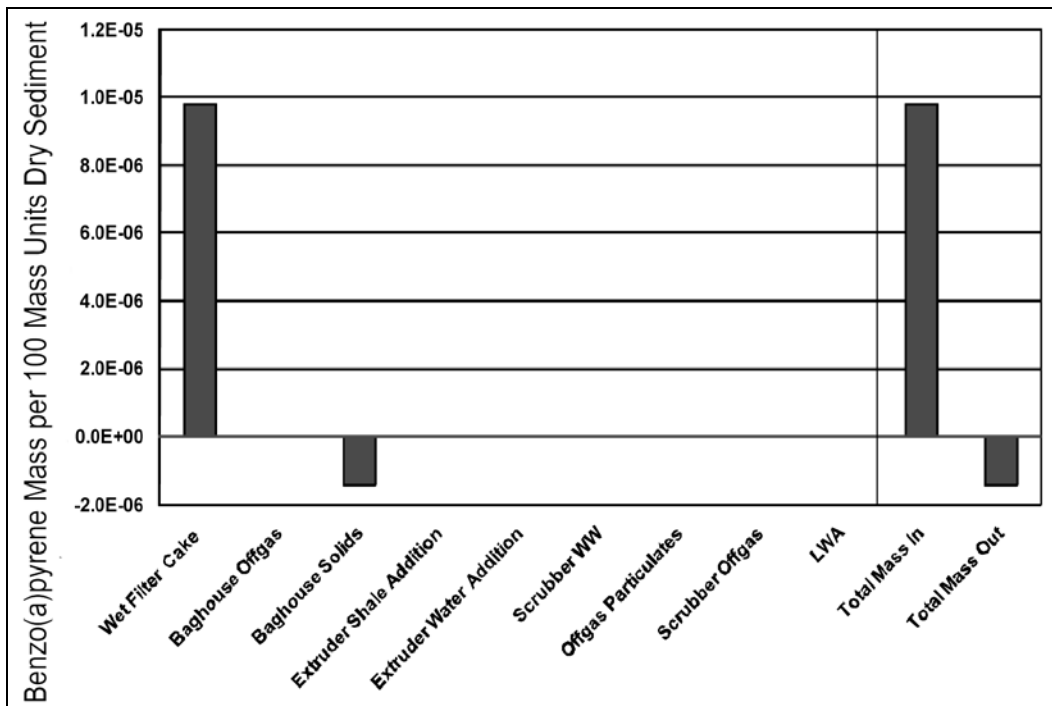

Figure 17. Fate of benzo(a)pyrene in rotary kiln.

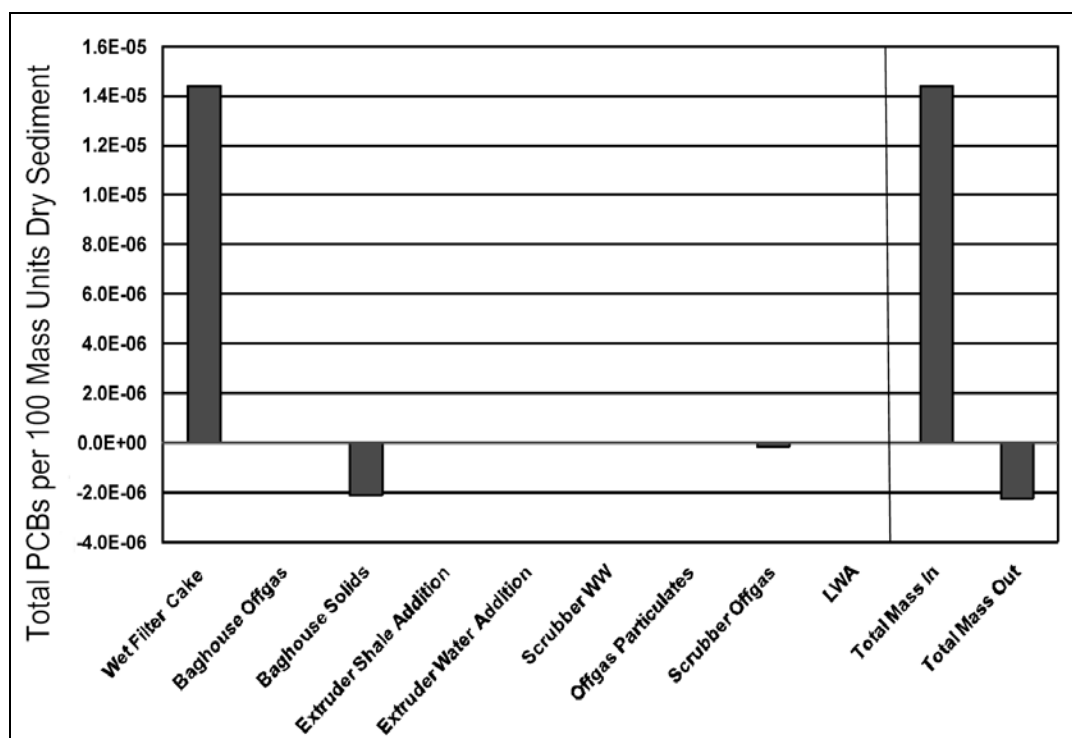

Figure 18. Fate of total PCBs in rotary kiln.

Technical issues

Mass balance issues

Not all contaminants were measured in all process streams (Table 17), limiting the analytes for which a full mass balance analysis could be done. PCBs, for example, were measured in the incoming sediment and dewatered sediment fines, but not in the filtrate or dewatered coarse fraction. PCBs were measured in the feed pellets but not in the added shale, dryer off-gases, dryer off-gas particulates, or dried filter cake. PCBs were measured in the aggregate, but not in the scrubber liquor.

From an operational standpoint, failure to characterize all inflows and outflows may not be a significant issue, as long as the contaminant concentrations in the treated sediment (produced LWA) are lower than the concentrations allowable for the designated beneficial use, and as long as residuals generation and capture are not unacceptable. Also, some contaminants, such as sulfur dioxide and nitrogen oxides, would be generated by the thermal process so there is probably no need to measure them upstream of the kiln. However, failure to measure input and output of other contaminants at each step leaves the actual fate of the contaminants subject to interpretation and conjecture in some cases. Further, the

mechanism of removal and the contribution of each unit operation may be difficult to determine. As an example, TCLP metals were measured in the dewatered sediment and the produced aggregate, but were either not measured or not reported for the feed pellets (an intermediate material handling step preceding the kiln). As a result, the reduction in leachability attributable to the pelletizing process, where a potentially diluting material is added to the sediment and the composite compressed into a hard pellet, could not be distinguished from the reduction in leachability achieved through the thermal process.

Analytical issues

Analysis was conducted according to EPA methods. Conventional toxicity characteristic leaching procedure (TCLP) and multiple extraction procedure (MEP) were applied for VOC, SVOC, and metal extraction analysis from the aggregate product. Total residual metals concentration was also measured in the aggregate product, although in some cases the mass measured using TCLP exceeded residual mass measured in the aggregate.

Leaching tests are satisfactory for evaluation of potential for leaching of residual contaminants from the aggregate, but insufficient to account for contaminant mass incorporated in the aggregate matrix. Definitive accounting of metals present requires acid digestion of the aggregate. As previously stated, there is no corresponding procedure for measurement of encapsulated organic compounds not extractable with solvents.

Operational Issues

The sediment must be dried and ground to the extent that it is fine and free-flowing prior to mixing with the shale for extrusion. A hammermill dryer/grinder was employed for this purpose. Problems were encountered with sticking and material build-up in the hammermill inlet chute and in the hammermill. This was resolved by mixing already dried material recovered from the baghouse with the incoming feed on an approximate 1:1 ratio.

Careful and complete debris removal is required in order to facilitate hydraulic offloading of mechanically dredged material, and as preparation for the dewatering processes. In situ debris removal will likely be required followed by a scalping process upstream of the dewatering equipment.

Hydraulic offloading of the mechanically dredged sediments proved to be cleaner and faster than mechanical offloading, avoiding concerns related to contaminant releases associated with spillage, and minimizing rehandling and barge demurrage.

JCI/Upcycle rotary kiln capacity

Based on the average rotary kiln system material balance for two runs and the reported feed pellet mix, each unit of dredged material filter cake yielded 0.55 units of LWA product. (Correspondence of LWA production to in situ sediment production will vary with grain size distribution of the sediment, since the sand fraction is removed from the process prior to treatment, and will vary by site.) Aggregate was produced at 14.8 kg/hr (32.7 lb/hr) in the pilot scale facility.

Based on reported processing rates, material dewatering for the pilot study was performed with commercial scale equipment, whereas the extrusion and kiln unit operations used pilot-scale equipment. Pilot testing is often conducted with readily available equipment, which may not be well matched with respect to capacity, and in some cases this impacted processing rates attained in the demonstrations. At scale up this may be addressed with appropriately sized equipment. Alternatively, dewatered material could be stockpiled for treatment if sufficient area were available.

JCI/Upcycle rotary kiln residuals

Residuals produced by the pretreatment stage of the process include debris, oversize materials, and filtrate from the dewatering process. Wash water from cleaning of debris will also be produced but may be recycled during operation to minimize total discharges.

Residuals produced by the treatment stage of the process will include spent sorbents, particulates, and scrubber water from the off-gas treatment. Scrubber water could potentially be recycled through the process, as it is for other thermal technologies, thus minimizing or eliminating aqueous discharges. Although significant contaminant reduction appears to have been achieved in the scrubber, further capture in a carbon column or other process may be required, depending upon concentration of emissions and applicable air quality standards. Constituents observed in the scrubber inlet and outlet were as follows:

Inlet

- Measurable concentrations of SO₂, NO_x, CO and VOCs
- Measurable concentrations of PCDDs and PCDFs
- Measurable concentrations of PCBs
- Measurable concentrations of metals
- Measurable halogens, ammonia and chlorine
- Measurable hexavalent Cr

Outlet

- CO non-detect
- SVOCs largely non-detect, total SVOCs reduced an order of magnitude
- PCDDs and PCDFs (as Toxicity Equivalency Quotient) reduced by more than two orders of magnitude
- PCBs reduced by one to two orders of magnitude at scrubber outlet (PCBs and chlorine measured in scrubber off-gases represented less than 0.6% of mass coming into the kiln phase from the dewatering phase)
- Metals reduced by one to two orders of magnitude in most cases, but with one exception the same metals that were measurable at the inlet were measurable at the outlet
- All chlorine non-detect at scrubber outlet
- Hexavalent Cr non-detect

Little data is available with respect to the volumetric or mass production of residuals relative to the volume of sediment processed. The limited data available were summarized in Table 5, in the process brief section of this report.

Beneficial use product

Physical properties of the LWA and suitability for various uses were evaluated through a suite of tests, including:

- Gradation (ASTM 136)
- Particle size analysis
- Density (compaction and vibratory methods)
- Unit weight (ASTM C-29)
- Organic impurities (ASTM C-40)
- Staining & Iron Content (ASTM C-641)

- Fe₂O₃
- Clay lumps & friables (ASTM C-142)
- Loss on ignition (ASTM C-114)
- Drying/shrinkage (ASTM C-157)
- Pop outs (ASTM C-151)
- Freezing & thawing (ASTM C-67)
- Thermal conductivity (ASTM C-177)
- Crushing strength
- Strength (triaxial compression and direct shear)
- Moisture absorption

Tested properties of the aggregate, with the exception of gradation, met ASTM requirements for Lightweight Aggregates for Structural Concrete (ASTM C-330) and reportedly also meets construction industry specifications for use as construction grade LWA.

Bulk density of the LWA tested was 602 kg/m³ (37.59 lb/ft³). Average crushing strength exceeded 97 kg (214 lb), reportedly comparable to or greater than other commercially available LWA, and moisture absorption levels were below the generally accepted maximum values of 15-20%.

Maximum density results were 817 kg/m³ (51.0 lb/ft³) (maximum index density test) and 841 kg/m³ (52.5 lb/ft³) (Proctor compaction test). Vibratory compaction resulted in a friction angle of 47.5 deg and the tamping method a 46.0-deg angle.

From a geotechnical perspective, project specifications are traditionally tailored to the specific project. STS Consultants' experience (JCI/Upcycle Associates, LLC 2002), however, indicates that project specifications often require a minimum friction angle of 35 deg for materials to be used for embankments or reinforced walls. The aggregate produced during the pilot project falls within the 35-deg requirement.

The consolidated drained triaxial test results were almost identical for the two compaction methods employed. A friction angle of 38.5 deg was determined for the vibratory compacted samples versus a friction angle of 38.0 deg for the tamped specimens. Any influence due to the compaction methods was not apparent. Both specimens displayed little material degradation during the shearing process as indicated by the particle size distribution curves.

In the 2004 process update the vendor reported an identified market for 800,000 mtons (900,000 tons) of lightweight aggregate in the northeastern United States. As stated in Chapter 2, the market value for LWA actually produced from contaminated sediments has yet to be demonstrated.

Cement-Lock® mass balance

Operational description

During the Cement-Lock® process, a mixture of sediment and modifiers is charged to a rotary kiln or “Ecomelt® Generator.” The process consists of two phases: (i) the pretreatment phase (debris removal and size separation, dewatering and drying of the raw feed), and (ii) the treatment phase, which includes the rotary kiln. In the pretreatment phase, debris and solids typically larger than 50 mm (2 in.) (gravel and cobbles) are removed, reduced in size, or separated from the fine fraction. Oversized materials are cleaned and disposed of as appropriate. The fine fraction is dewatered and dried, and subsequently blended with modifiers and fed to the kiln (or “Ecomelt® Generator”). The major components of the system are listed in Table 6, and a process flow diagram of the Cement-Lock® technology is provided in Figure 6.

The Ecomelt® Generator is operated at a temperature of 1,400 to 1,500 °C (2,600 to 2,700 °F), causing the minerals in the sediment and modifier mixture to react together. After a sufficient residence time in the melter, the melt is discharged and then quenched with water to granulate the material. Flue gas from the Ecomelt® Generator flows to the secondary combustion chamber (SCC), to ensure complete destruction of any residual organic material.

The flue gas exiting the SCC is rapidly cooled to prevent the formation of dioxin or furan precursors. Powdered lime (CaO) is injected into the cooled gas to capture sulfur oxides and hydrogen chloride. This spent lime mixture is removed from the flue gas stream by a bag house, containerized, and disposed of in a proper manner. Volatile heavy metals, such as mercury, are removed from the flue gas via a fixed bed of activated carbon. Powdered activated carbon could also be injected directly into the flue gas downstream of the lime bag house, and then captured in another bag house.

Mass balance

Data from the 2006 and 2007 Cement-Lock[®] extended duration pilot tests were used to reconstruct the materials mass balance throughout the treatment process and the mass balance distribution of contaminants. The mass balance calculations contribute to an understanding of where treatment is occurring and the fate of the contaminants through the Cement-Lock[®] treatment process.

Table 18 summarizes the sampling and testing program conducted for the Cement-Lock[®] process. Samples were collected from the dried sediment entering the Ecomelt[®] generator (kiln), the quenched Ecomelt[®] from the granulator, flue gas from the bag house to the carbon column, clean exhaust gas from the carbon column, and vapor from the granulator. Due to improper operation of the bag house, spent lime samples were not analyzed, and thus the bag house is not evaluated as an independent treatment process in the mass balance. Contaminant data for the spent carbon were also not available.

Material flow into the system was calculated based on feed rates of raw sediment and modifier to the Ecomelt[®] Generator.

Materials mass balance

Appendix C shows the materials mass balance for the Cement-Lock[®] extended demonstration tests. In summary, a total of 25,000 kg (56,200 lb) of sediments (27.5% moisture) and 7,130 kg (15,720 lb) of modifier were treated resulting in 21,092 kg (46,500 lb) of quenched Ecomelt[®]. The materials mass balance is also illustrated in Figure 19.

Contaminant Mass Balance

Contaminant mass balance data for the Cement-Lock[®] extended duration test with Passaic River sediments are illustrated for selected contaminants in Figures 20 through 24. Note that where total mass in and total mass out are not equal, this is indication of failure to close the mass balance, which may be due to material variability, contaminant destruction, or system losses.

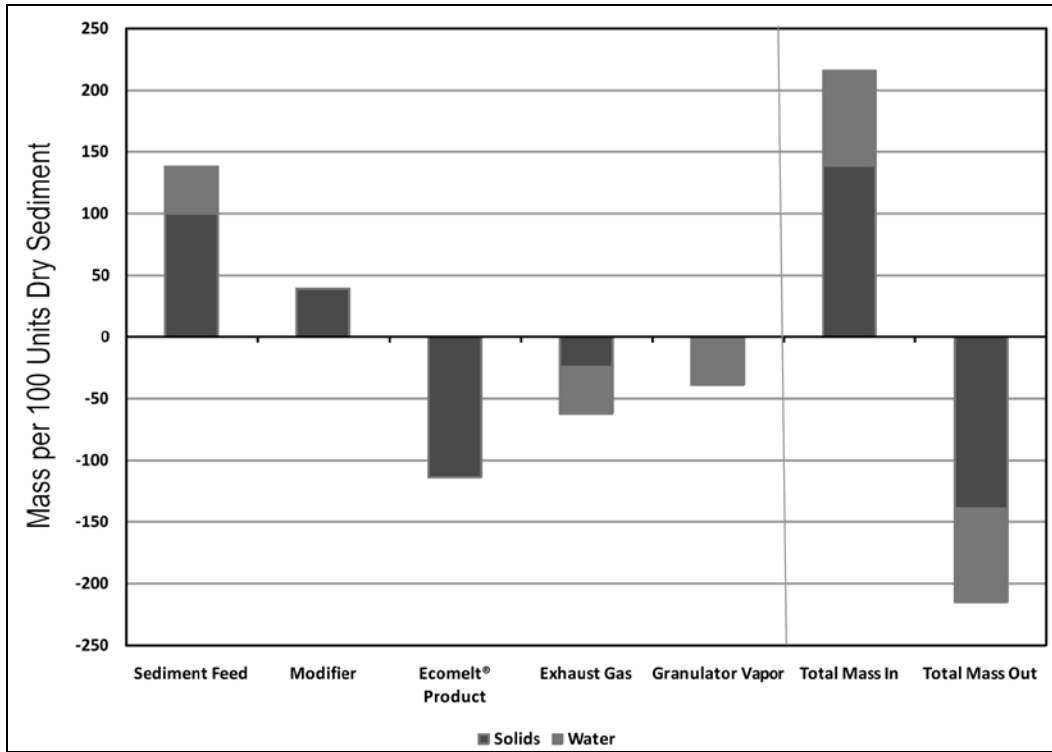

Figure 19. Cement-Lock® materials mass balance based on 100 mass units dry sediment solids treated.

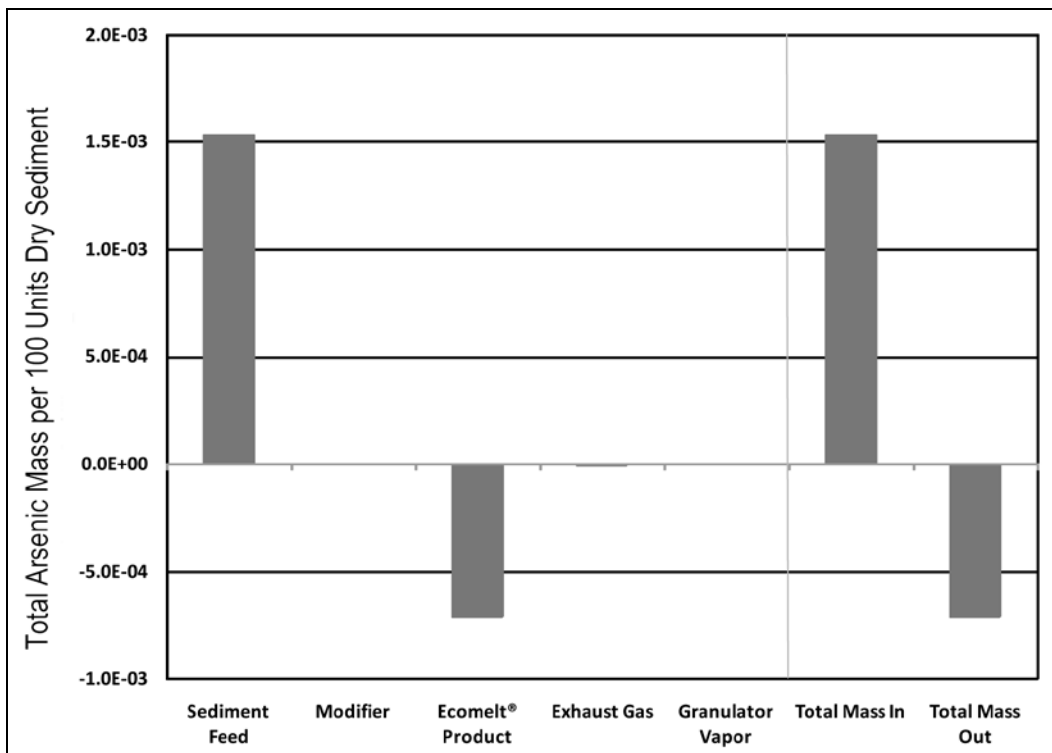

Figure 20. Fate of arsenic mass in Cement-Lock® process.

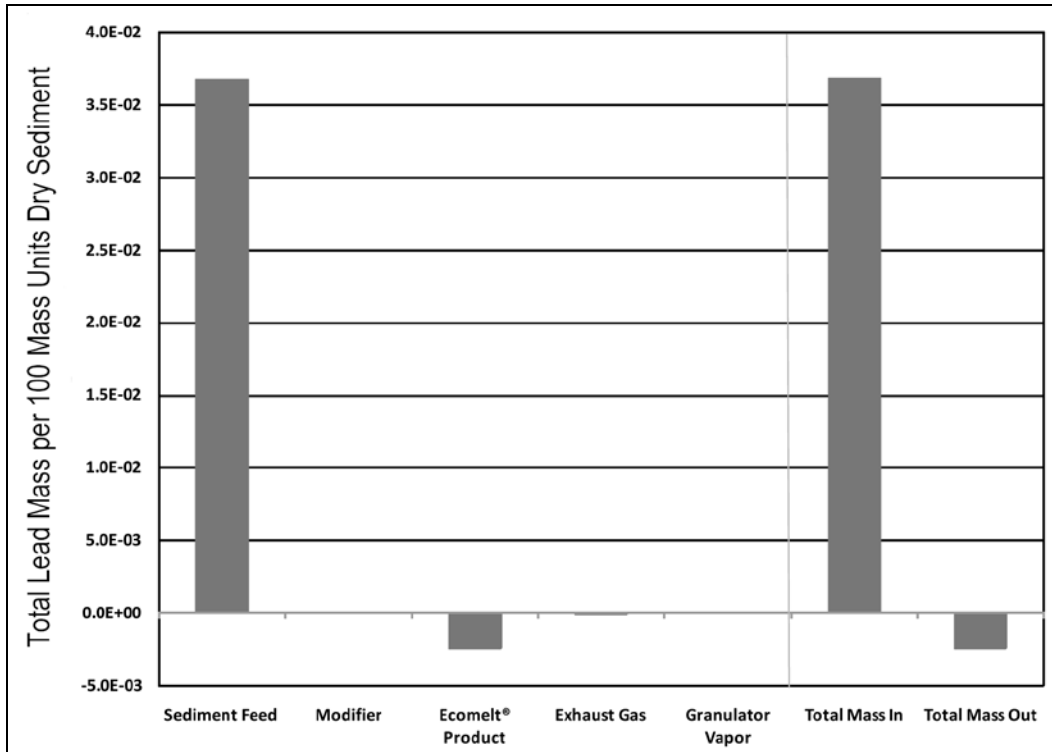

Figure 21. Fate of lead mass in Cement-Lock[®] process.

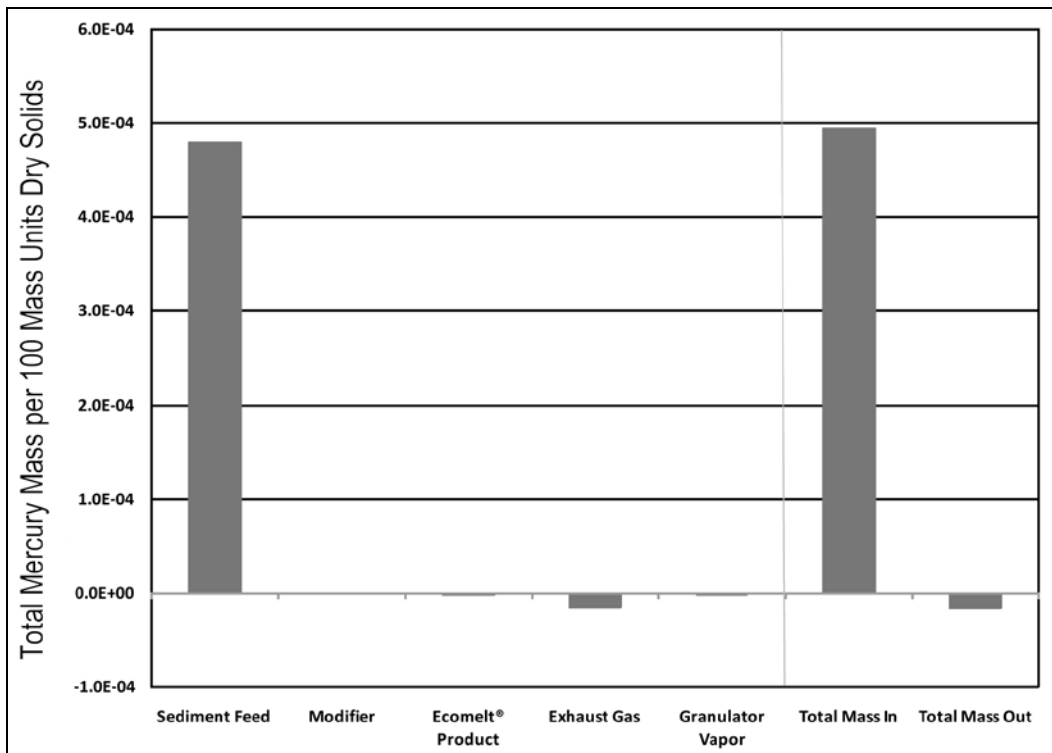

Figure 22. Fate of mercury mass in Cement-Lock[®] process.

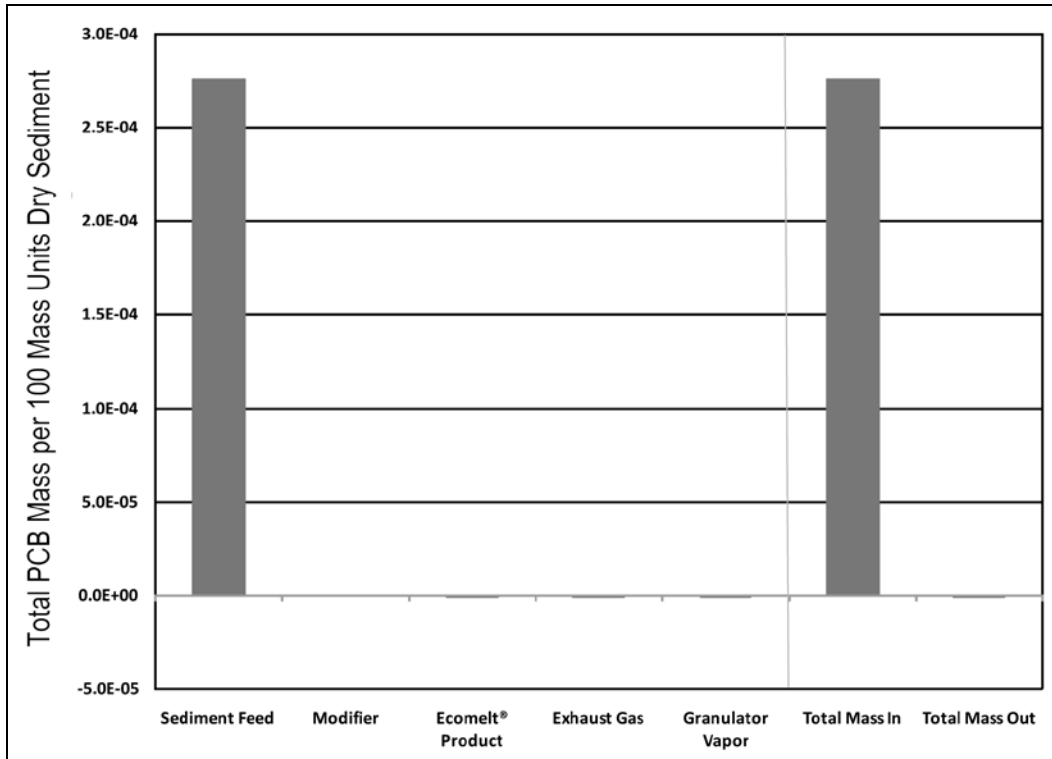

Figure 23. Fate of total PCB mass in Cement-Lock® process.

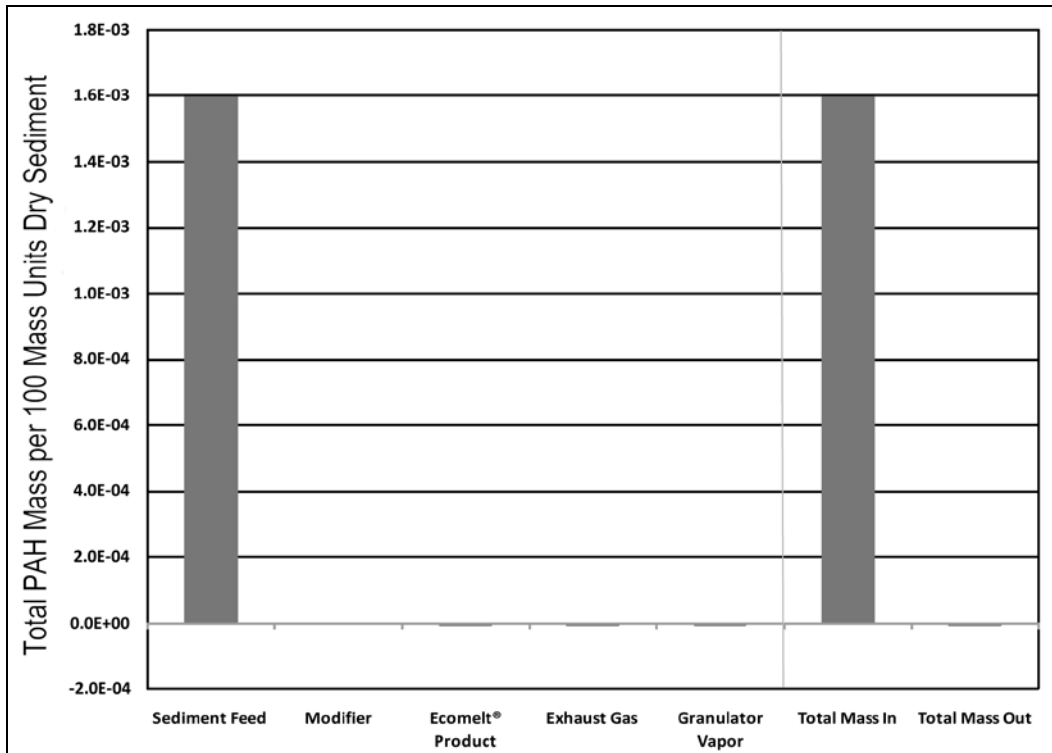

Figure 24. Fate of total PAH mass in Cement-Lock® process.

Based on the mass balance, about 46% of the arsenic mass and 7% of the lead mass were accounted for in the measured output streams, as shown in Figures 20 and 21. As shown in Figure 22, greater than 40% recovery was reported for mercury from the combined mass in the Ecomelt[®], flue gas to the carbon column, and vapor from the granulator. The flue gas treated by the carbon column contained 8% of the mass entering the carbon, suggesting effective mercury removal by the carbon. However, the mass balance around the carbon cannot be closed because the carbon was not analyzed. The demonstration project did not analyze the carbon because the carbon bed was used for processing materials outside the monitored demonstration campaigns and because of logistical problems in obtaining a representative sample of the 9,979 kg (22,000 lb) of carbon pellets.

Comparison of incoming total PCB (sum of 209 congeners) mass to mass entering the carbon column suggests a large proportion of the PCBs were destroyed in the high-temperature treatment units including the Ecomelt[®] generator and the secondary combustion chamber, with much of the remainder removed in the carbon column (Figure 22). More than 99.6% of the PCB mass was unaccounted for in the output streams. More than 99.9% of the total PAHs were unaccounted for, and appear to be attributable to thermal destruction as minimal levels were measurable in the carbon column inlet gas. Spent carbon represents a process waste stream that must be managed as an output stream.

Taking into account the total (digested) metal concentrations in the process solids, the percentage of lead and other metals mass unaccounted for is likely attributable to immobilization in the product and unsampled or unanalyzed process streams. Contaminants in the gas streams entering and exiting the carbon column were analyzed. However, spent lime collected in the bag house was not analyzed, nor was the spent carbon. It is expected that some of the input metals mass was removed from the flue gas as particulate matter in the bag house. In addition, it is expected that following thermal treatment some of the metals mass, particularly lead due to its moderate volatility, accumulated as fly slag, which coated the walls of the secondary combustion chamber, or as particulate matter in other cooler downstream sections of the process plant.

Technical issues

Mass balance issues

Contaminants were not measured in all process streams, limiting the extent to which a full mass balance analysis could be completed. For example, samples from the flue gas to the bag house were not collected or analyzed, nor were solid samples from the bag house or spent carbon. Thus, it was not possible to include this process in the mass balance calculation. In addition, it is assumed that a percentage of the lead mass was retained in the secondary combustion chamber walls, which was also not sampled or accounted for in the mass balance calculation.

The failure to measure contaminant concentrations in the flue gas to the bag house and the bag house solids prevents an accurate estimate of contaminant fate during the Cement-Lock[®] treatment process, but is not expected to be an issue as long as the residuals generation and capture are acceptable. However, these assumptions would need to be tested during operation at any new plant and before the treatment of any highly contaminated material.

Analytical issues

The results of the TCLP tests for arsenic, chromium, lead, mercury, and manganese on the Ecomelt[®] from the Cement-Lock[®] demonstration were below detection limits. This is not a concern with regards to comparison of TCLP results to regulatory limits, as the detection limits were well below the regulatory limits. Barium, cadmium, chromium, copper, manganese, nickel, and zinc were above the detection limit, but below regulatory concentration limits.

Operational issues

Engineering and operational problems were encountered during pilot demonstration tests that would need to be reevaluated or redesigned for a commercial-scale Cement-Lock[®] treatment facility. For example, slag accumulated in the drop-out box and plugged the slag discharge, despite the fact that the plant had been modified to the maximum extent practicable to address this issue. The drop-out box configuration would need to be redesigned in accordance with industry criteria for continuous slagging operations to be successful (Mensing 2008b).

During the pilot scale tests, the powdered lime flowing into the duct upstream of the bag house was inconsistent, leading to inconsistent discharging of the spent lime from the bag house. In addition, higher than expected sulfur oxide and particulate emissions were measured, which may have resulted from bag tears inside the bag house, decreasing the efficiency of particulate capture in the bag house. In commercial-scale operations, the design of the lime feeding system would need to be improved, and equipment to detect potential bag breakage may need to be installed. Sulfur oxide was also detected in offgases during the Phase II testing (Mensinger 2008a) and was removed in the activated carbon bed with average efficiency of 94.9%, and average treated emissions concentrations of 7.7 ppmv.

Cement-Lock® capacity

During the Cement-Lock® extended duration tests with Passaic River sediments, a total of 28.7 mtons (31.6 tons) of Passaic River sediment and modifiers, which is equivalent to approximately 34 m³ (44 yd³) of sediment in situ, were processed through the demonstration plant at rates up to 0.8 m³/hr (1 yd³/hr) (Mensinger 2008b). An estimated total of 21 mtons (23 tons) of Ecomelt® was produced as part of these extended campaigns. However, as previously mentioned, both extended duration tests experienced equipment-related problems and operational issues, which led to involuntary termination of the demonstration. Thus, reliable, sustained operation has not yet been demonstrated.

Cement-Lock® residuals

Solid process residuals from the Cement-Lock® treatment processes include debris removed in the pretreatment step and the spent lime-salt-sulfur mixture from the bag house, both of which would need to be disposed of in a proper manner.

Based on concentrations of SO₂, NO_x, CO and VOCs measured in the flue gas from the outlet of the activated carbon bed, additional treatment of gas emissions may be required. Mensinger (2008a) reported that NO_x emissions would exceed the New Major Facility Threshold Level if the demonstration plants were to be operated for a full year, thus emissions would need to be further controlled in a commercial-scale plant. Carbon capture efficiencies are summarized in Table 19.

Table 19. Average activated carbon capture efficiencies for contaminants of concern during extended duration tests with Passaic River sediments.

Analyte	Carbon capture efficiencies
Total metals ¹	59%
Mercury	92%
Lead	7.4%
Total PCBs ²	61%
<p>1 Total of As, Ba, Cd, Cr, Co, Cu, Hg, Mn, Ni, Pb, Se, Ag, and Zn</p> <p>2 PCB capture efficiency averaged 99% during the first campaign, but less than 46% during the second campaign.</p>	

Although flue gas samples collected upstream and downstream of the activated carbon bed demonstrated over 92% capture of the mercury mass, low but measurable concentrations of mercury were still detected in the outlet of the activated carbon bed. Thus, priority air pollutants, such as mercury and lead, must also be carefully monitored and controlled at a commercial-scale facility.

Beneficial use product

As discussed in the technology brief section, the Cement-Lock[®] technology produces two distinct beneficial use products. From the slagging mode of operation, the decontaminated dredged sediment is converted into Ecomelt[®], a material demonstrating pozzolanic properties. The Ecomelt[®] is pulverized and mixed with proprietary additives to create a blended cement product. Under the non-slagging operation mode, sediment is converted to EcoAggMat, which can be beneficially used without further treatment, as fill or as a partial replacement for sand in concrete.

Tests were conducted on a batch of concrete in which Ecomelt[®] from the Passaic River sediments replaced 40% of the Portland cement normally required (Mensing 2008a). Table 20 shows the results of the compressive strength tests. After 28 days of curing, the Ecomelt[®] blend achieved 39.3 MPa (5,700 psi), while the control achieved 41.0 MPa (5,950 psi). After 56 days of curing, both the Ecomelt[®] blend and control concrete achieved 45.9 MPa (6,650 psi). Thus, Ecomelt[®] blended cement may require an accelerator for high early strength applications but otherwise has the potential to develop comparable compressive strength to conventional concrete (Mensing 2008a).

Table 20. Results of compression strength tests comparing Ecomelt® blended concrete (40%) to neat Portland cement concrete¹.

Days of Curing	Ecomelt®-Portland Blended Concrete	Portland Concrete	ASTM C595 Specification
	Compressive Strength, MPa (psi)		
3	25.4 (3,680)	25.4 (3,680)	25.4 (3,680)
7	23.8 (3,450)	23.8 (3,450)	23.8 (3,450)
28	39.3 (5,700)	39.3 (5,700)	39.3 (5,700)
56	45.9 (6,650)	45.9 (6,650)	45.9 (6,650)
1) Mensinger (2008a)			

Minergy glass furnace technology mass balance

Operational description

The Minergy Glass Furnace Technology heats sediment to high temperature (1600 °C (2900 °F)), oxidizing organics and incorporating inorganic constituents into molten glass produced by melting the silica components in the sediment. Sediment pretreatment to remove water to less than 10% moisture content optimizes the process. Oversize debris, trash, coarse solids (>9.5 mm (3/8 in.)), and metallic objects must be removed prior to feeding the dried sediment to the glass furnace. The mass balance evaluation described in this section for Fox River, WI, sediment is based on evaluation of Minergy's process by the USEPA SITE program in 2001.

A representative process flow chart for the initial dewatering phase of this technology was presented in Figure 9, although components could be varied depending upon the character of the sediment being processed and equipment available. Oversize debris is removed from the dredged material with a grizzly or other physical separation technology. Additional size reduction may be used to reduce the sediment volume requiring treatment if the coarser solids are not contaminated. The moisture content of the contaminated material is mechanically reduced to 50-60 percent by weight using a belt or chamber filter. Lime, flocculants, or other filter aids may be mixed with the sediment to condition the dredged material for filtration. Wash water for cleaning the debris and coarse material, as well as the filtrate from the dewatering equipment, represent residual streams that may require additional wastewater treatment unless they can be recycled within the process.

Sediment treatment plant unit operations were illustrated in Figure 10. The moisture content of the dredged material is further reduced from 50% to approximately 10% by indirect thermal drying. Water evaporated from the dredged material must be cooled and condensed, and particulate in the gas stream must be captured for incorporation into the feed to the glass furnace. The condenser water is a residual stream likely also requiring treatment. Remaining gases from the dryer are routed through the melter to achieve destruction of volatilized organics. A portion of the dried material is recycled and blended with the dryer feed to improve the handling characteristics (37% moisture¹) of material as it is fed to the dryer and as it moves through the dryer (Minergy 2002). Dried material, which tends to stick together and aggregate, is ground in a delumper prior to charging the melter. As fine-grained sediment dries, it becomes a dusty fine powder. Controls to capture fugitive dust are necessary throughout the drying and feeding process. Since the dust likely contains the same contaminants as the sediment, this dust would be collected and directed through the glass furnace for full-scale operation.

The melter is a refractory chamber heated by combustion of natural gas and oxygen. Sediment and flux material are charged to the melter by an enclosed and cooled screw conveyor. Flux is used to control melt temperatures and improve the qualities of the molten glass. A 5-% sodium sulfate flux was added for the pilot testing; Minergy recommended precalcined lime for full-scale production to improve energy efficiency and melting temperature and reduce emission control requirements. The molten glass proceeds from the melter through a heated outlet (forehearth) to a cooled water quench tank, where it solidifies and fractures into the glass aggregate product. A screw conveyor in the quench tank pulls the glass aggregate, a hard, dark, granular material, out of the water for beneficial use processing, including crushing to a specified grain size and mixing with other materials. The flue gases from the melter are treated to remove particulate, cooled and scrubbed in a packed tower, and passed through a carbon adsorption unit before being released to the atmosphere.

Mass balance

Process streams in Figure 10 for which there were contaminant mass data available are numbered, and correspond to column headings in the complete mass balance summary provided in Appendix C. Table 21

¹ This value is likely sediment-specific. More plastic materials (containing expansive clays) will be more difficult to handle and may require a lower moisture content than less plastic materials.

summarizes the process streams as stage inputs and outputs, and indicates which samples were analyzed for a given contaminant. The summary table is intended to provide sources of the information for ready reference, indicate which process streams were (or were not) accounted for, and illustrate any gaps in the chemical analysis that complicated mass balance reconstruction.

Gases from the melter were evaluated by collecting a slip stream of the flue gas through a water-cooled extraction probe. Analytical results are available for the processing of approximately 7,484 kg (16,500 lb) of dewatered sediment.

Materials mass balance

Pre-treatment. The sediment was prepared for the melter test by loading manually into drums and drying in a drum oven for 36 hr at low temperatures (less than $\sim 99^{\circ}\text{C}$, or 210°F). Dried sediment was passed through a delumper to reduce agglomerated particle size followed by a grate equipped with bar magnets to remove metallic debris. An estimated 27,216 kg (60,000 lb) of dried sediment were prepared for the melter test in this manner. Moisture content of the sediment was reduced from 50 to 10%. However, neither weights before and after drying nor weight water evaporated were reported. Based on the moisture content information, 48,988 kg (108,000 lb) sediment at 50 percent moisture were converted to 27,216 kg (60,000 lb) sediment at 10% moisture, assuming all the solids were retained. Metallic debris was also removed from the sediment prior to feeding to the melter, but the mass fraction for this residual material was not reported.

Treatment. The materials balance based on the SITE demonstration is presented in Appendix C, and it is illustrated in Figure 25 for a normalized 45 kg (100 lb) mass of dry sediment solids. Figure 10 tracks the materials through the process. The top number for each stream accounts for the sediment solids, and the bottom number tracks the mass of water associated with the sediment feed. Materials fed to the melter include sediment at 10% moisture and a sodium sulfate flux equivalent to 5% of the feed material. While the demonstration noted dust in the gas stream from the melter, the mass was not estimated. Therefore, the mass balance assumes that all the fixed (non-volatile) particulates in the sediment reported to the glass product, and that all the vaporized volatile solids and moisture associated with the feed reported to the gas stream from the melter.

Table 21. Sampling and testing matrix for Minergy GFT treatment stages and process streams

Parameter	Dryer				Melter						Quench Tank		Crusher		Cooling Tower			Carbon Filter										
	In		Out		In			Out			In	Out	In	Out	In	Out	In	Out										
	Dredged and Dewatered Sediment	Recycled Furnace Offgases	Dried Sediment	Dryer Condensate	Dryer Air and Dust	Dried Sediment	Sodium Sulfate Flux	Dryer air and Dust	Natural Gas	Oxygen	Molten Glass	Offgas/Flue Gas	Dust Accumulation on Probe	Molten Glass	City Water	Glass Aggregate	Quench Water	Glass Aggregate Product	Crushed Glass Aggregate Product	Flue Gas	City Water	Flue Gas	Cooling Tower Discharge Water	Flue Gas	Clean Carbon	Flue Gas	Spent Carbon	
Mass Flowrate			X ⁵			X ^{6,7}			X ¹⁰	X ¹⁰								X ¹²										
Solids Mass						X ⁸												X ⁸										
Water Mass																												
Gas Mass																												
Percent Moisture	X ^{1,2}					X ^{1,2,9}																						
Contaminant Mass																												
Contaminant Concentration																												
TCLP Results																												
SPLP Results																		X ^{4,13}	X ^{4,14}									
MEP Results																												
Metals	X ³		X ³	X ³	X ³	X ⁴	X ⁴					X ⁴	X ⁴	X ¹¹	X ⁴	X ⁴	X ⁴			X ¹⁵		X ⁴				X ⁴		
PCBs	X ^{3,4}		X ^{3,4}	X ³		X ⁴	X ⁴					X ⁴		X ¹¹	X ⁴	X ⁴	X ⁴			X ¹⁵		X ⁴				X ⁴		

SVOCs	X ³		X ³	X ³	X ³	X ⁴	X ⁴					X ⁴			X ¹¹	X ⁴	X ⁴	X ⁴			X ¹⁵		X ⁴			X ⁴	
Dioxins/Furans	X ³		X ³	X ³	X ³	X ⁴	X ⁴					X ⁴	X ⁴			X ⁴		X ⁴								X ⁴	
Pesticides																											
TPH																											
NO _x																											
SO ₂																											
SO _x																											
O ₂																											
CO																											
CO ₂																											
VOCs						X ⁴						X ⁴				X ⁴											
HCl												X ⁴															

1 See p. 41 of Section 4 of USEPA (2004); these percent moisture values are design values and are not measured
 2 See p. 17 of Minergy (2003c); these percent moisture values may be more representative of dredged and dewatered sediment and of dried sediment
 3 See Table C-1 through C-4 in USEPA (2004); these results Holoflite dryer. Drum dryer not configured for sampling of exhaust or condensate.
 4 See Tables 4-2 through 4-11 in USEPA (2004)
 5 See p. 51 of Section 4 of USEPA (2004)
 6 The chart on p. 22 of Minergy (2003c) displays melter feed records for the June 2001 run (presumably in lb/hr vs hrs format)
 7 The chart on p. 23 of Minergy (2003c) displays melter feed records for the August 2001 run
 8 See pp. 23-24 of Section 2 in USEPA (2004)
 9 See p. 25 of Minergy (2003); this is another range of percent moisture for dried sediments
 10 See Table 1-1 in USEPA (2004); note: these are flowrate estimates
 11 Table states that these analyses were conducted; however, data for these analyses cannot be located in the report
 12 See p. 55 of Section 4 of USEPA (2004)
 13 The SPLP Leach Test (metals, PCBs, SVOCs, and dioxins/furans); the ASTM Leachate Tests (metals, PCBs, SVOCs, and dioxins/furans)
 14 The SPLP Leach Test was conducted for metals and PCBs
 15 Analyses of input city water for the quench tank can approximate water chemistry for cooling tower input city water

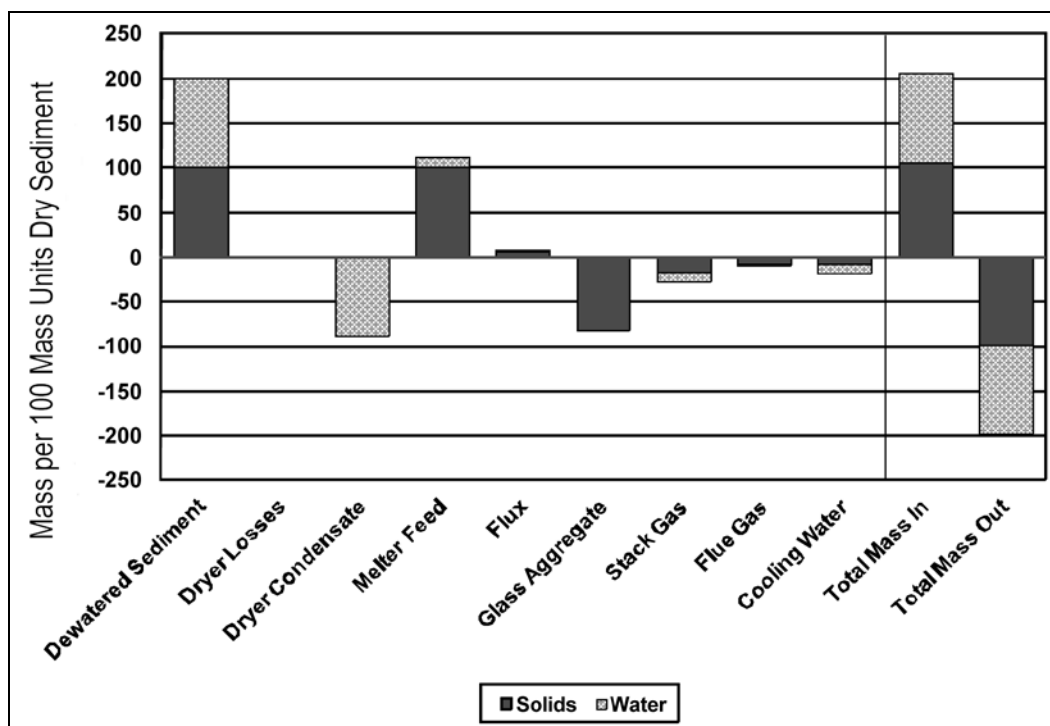

Figure 25. Minergy GFT materials balance results.

Not shown in the mass balance tables are the fuel and oxygen injected into the melter to provide the energy to heat the solids to 1600 °C (2900 °F). The combustion products (carbon dioxide and water) as well as oxides of sulfur and oxygen and particulates collectively make up the off-gas stream from the process. The USEPA (2004) report characterized the flue gas from the melter, the cooling water discharge, the quench water, and the gas exiting the carbon column chemically, but did not estimate the mass or volumetric flow. Appendix C estimates the gas streams based on water and volatile solids vaporized from the sediment, but the total materials mass is understated because it does not include the combustion products from the fuel and oxygen. The sediment total solids balance closed to within 7% of the feed. Because of the assumptions made regarding the water, the water mass going out equaled the water mass coming in.

Contaminant mass balance

Pre-treatment. Emissions from the drum dryer system used for preparing the sediment for the glass furnace were not sampled or characterized for contaminants. Sediment samples collected before and after drying were analyzed for PCBs, but not metals. The initial PCB concentration averaged 29 ppm and the final concentration averaged 22 ppm—a statistically significant difference ($\alpha=0.05$)—suggesting that a fraction of the PCBs

were lost to the gas phase. (Because no materials mass data were available for the pre-treatment stage, contaminant mass could not be estimated.) A separate dryer investigation was conducted on a subsample of the sediment at Hazen Research, Inc. facilities. However, some of the laboratory analytical data, particularly for PCBs, were questioned, and the PCB results from this investigation were not used by the SITE investigation. However, metal concentrations from the Hazen tests were used in the mass balance for the dryer stage (only) reported in Appendix C. Metals concentrations were changed very little during the drying process, but simple concentration comparisons likely do not account for particulate associated losses. The condensate analyses indicated detectable concentrations of arsenic, barium, and mercury. The mass balance around the solids for the dryer stage (Appendix C) shows that 3-13% of the heavy metals were lost, with arsenic being reduced by 13% and the remainder of the metals changing by less than 5%.

Treatment. The results of the contaminant mass balance conducted for the SITE pilot study (to the extent that the data allow) is presented in Appendix C. Overall process efficiency and core treatment (melter) efficiency were evaluated by constructing a materials balance for all process streams and calculating mass of contaminant reporting to each stream for total PCBs and select heavy metals. Data used were the analytical data provided in the SITE report for the second five-day melter test. Contaminant concentrations in dewatered sediment, drum-dried sediment (taken following drying), melter feed (drum-dried sediment sampled at the time of the demonstration), flux, melter off-gases before and after carbon filtration, dust, and quench tank water were summarized in the SITE report. The contribution of dust to process output was neglected as the mass of dust produced was not reported and this process stream, according to Minergy, would be more completely controlled at full scale (collected and recycled to the melter feed). In addition, three different types of leachate tests were conducted on the glass aggregate. Metals and PCBs were below detection limits for all leachate samples. Decontamination efficiency of the glass furnace based on leachable metals and PCBs would be 100%. The SPLP leachate was observed to contain total dioxins and furans (TCDD/PCDF) concentrations ranging from 0.0332 to 0.615 ng/L (3.33×10^{-8} to 6.15×10^{-7} ppm). On a mass basis this would represent less than 0.05% of the TCDD/PCDF in the melter feed (an efficiency of 99.95%).

Figures 26–30 illustrate the mass balance for selected metals and total PCBs. Based on inputs and outputs, more than 99.999% of the PCBs were not accounted for and may be presumed destroyed in the overall mass balance for the melter system. The mass of PCBs in the waste and product streams in Figure 30 do not appear because they are so small compared to the feed material. However, the mass balance under-estimates the mass of contaminants in the off-gas stream because the methane and oxygen components were not included. The accounting for heavy metals ranged from minus 270% for barium (more mass measured in output streams than in input streams) to 99% for arsenic, cadmium, and mercury (total mass unaccounted for). Metals unaccounted for may have released into the stack gases where they could have been collected as dust, condensed in the cooling tower, adsorbed to the activated carbon column, or escaped as flue gas. Although analyses of the flue gas streams from the melter and from the carbon column for heavy metals were all below detection limits, metals were found in the dust and the cooling tower condensate or blowdown. Some of the heavy metals and PCBs would be expected on the carbon, but the evaluation did not analyze the carbon, making the spent carbon an unknown component for the mass balance. Negative values for organic and some inorganic constituents in the mass balance could suggest that those compounds were produced in the process, however for heavy metals, this can only be attributed to material or sampling and analytical variability.

Technical issues

Mass balance issues

A complete mass balance for the Minergy Fox River demonstration is not possible without making a number of assumptions regarding the mass of material reporting to each compartment. The masses of melter feed and glass product for the overall project run were reported. However, information to assign a mass to the quench water and cooling tower water were not included in the SITE report. Also, gas flow rates, which are needed along with flue gas composition to calculate the mass of materials and contaminants in that process stream, were not reported.

Samples for the melter stack gas were collected from a subsection of the total gas flow. Dust accumulated on the cooled sampler intake pipe and required periodic cleaning. A sample of the dust was analyzed, but there were no measurements or estimates for the dust mass.

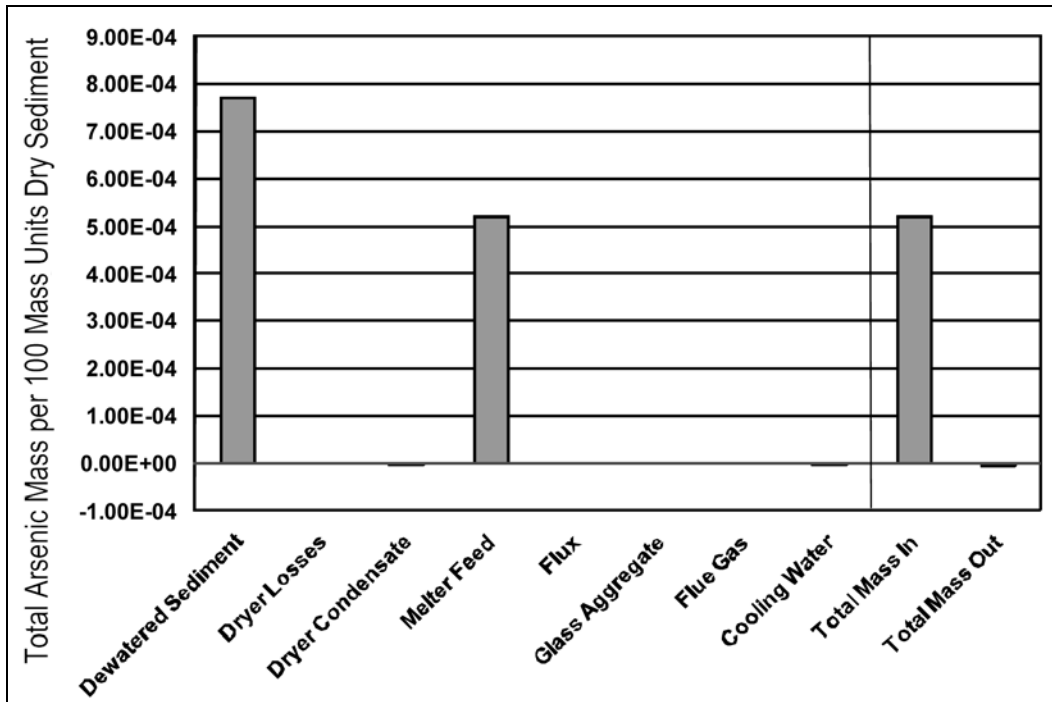

Figure 26. Fate of arsenic mass in Minergy GFT process.

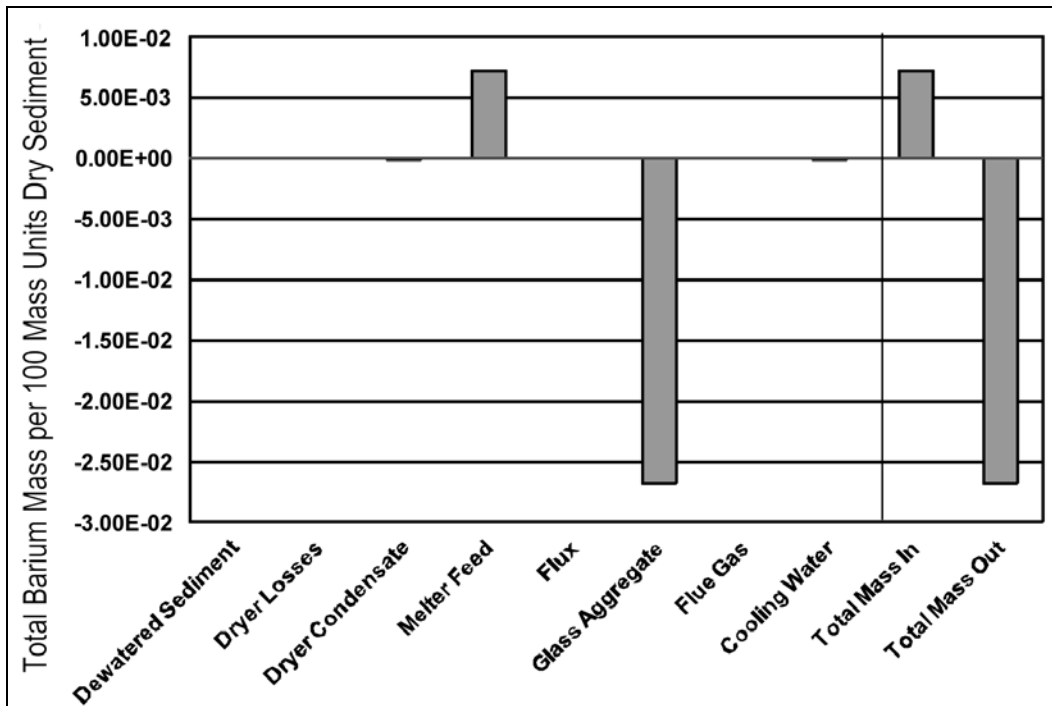

Figure 27. Fate of barium mass in Minergy GFT process.

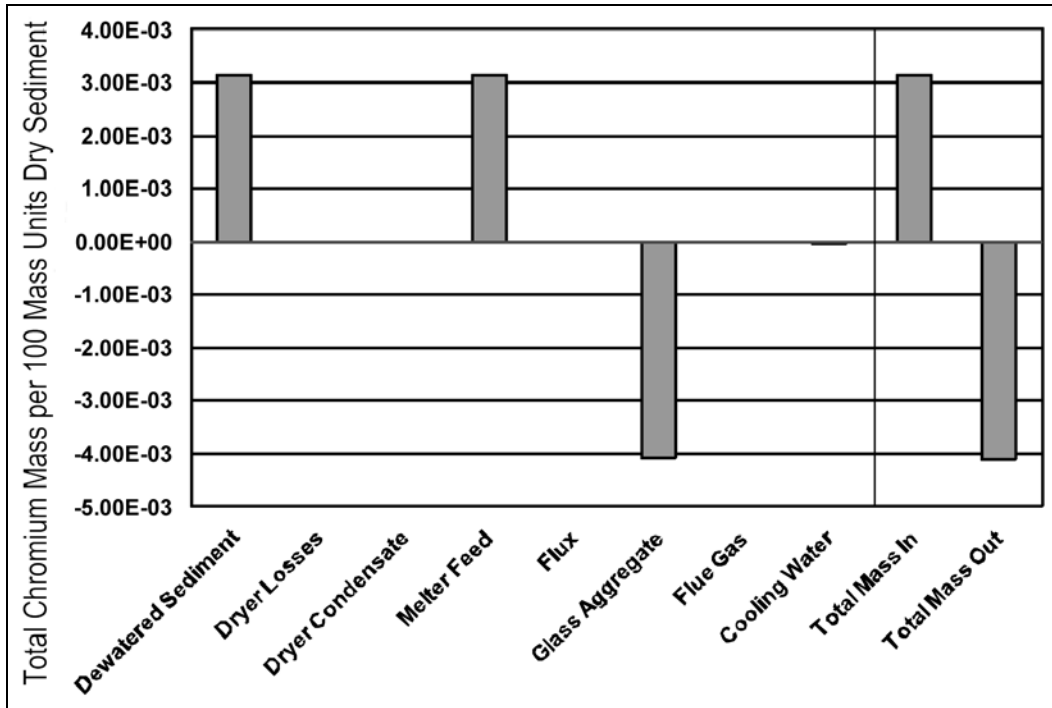

Figure 28. Fate of chromium mass in Minergy GFT process.

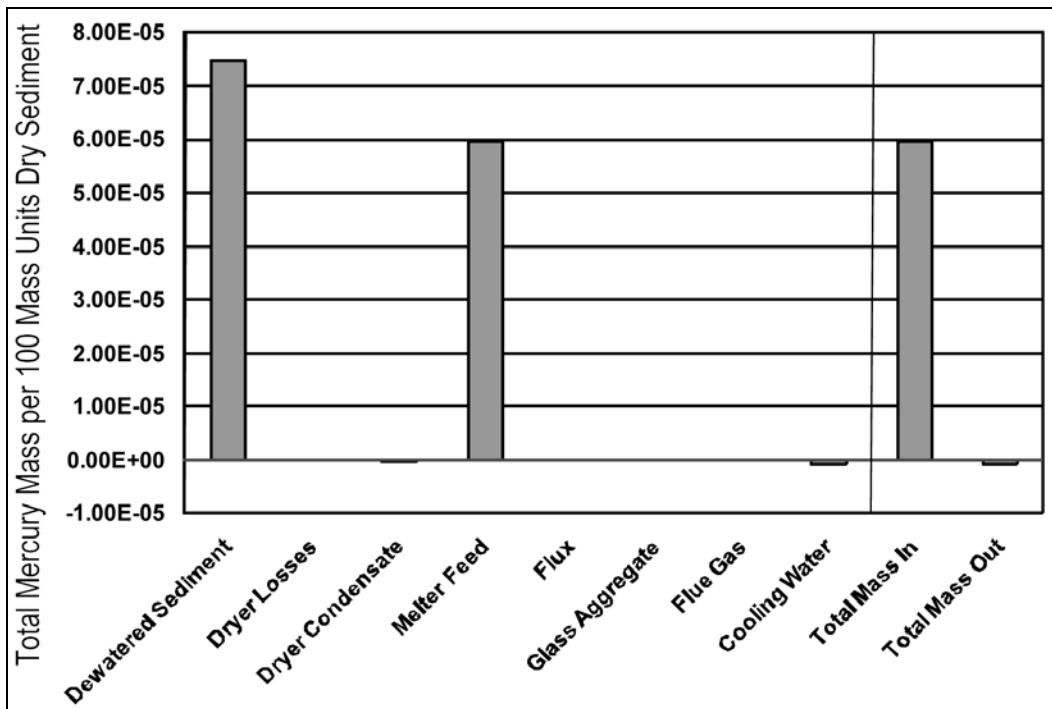

Figure 29. Fate of mercury mass in Minergy GFT process.

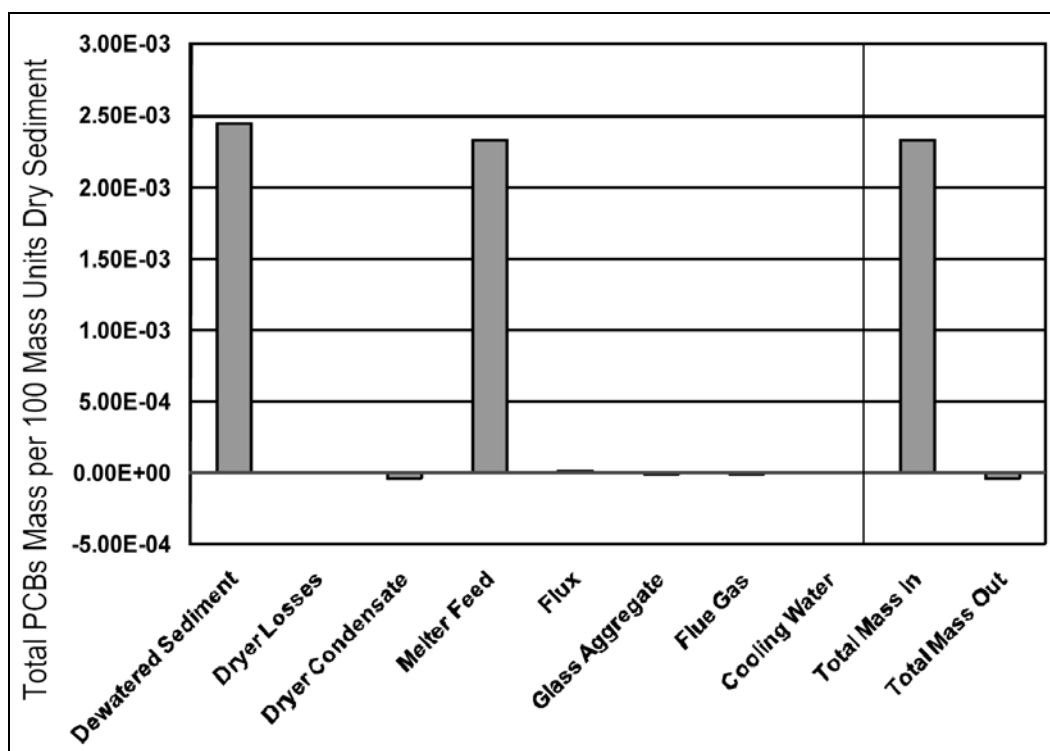

Figure 30. Fate of total PCB mass in Minergy GFT process.

The Minergy GFT is a continuous process. One of the difficulties of monitoring continuous processes is in obtaining truly "paired" samples of input and output materials. Sampling of feed and glass aggregate was staggered by 6 hr (the residence time of sediment in the melter) in an attempt to address this. Although flow through the melter can be modeled as plug flow (Beerkens 2002), the complexity of material flow through the melter due to convective currents complicates the actual picture, and residence times of off-gases and solid materials in the system are different. In this case, comparison of mean concentrations in composite samples from process streams probably provides the most meaningful data, as well as capturing variations in operation over time. For the SITE Program pilot test, sediment, glass aggregate, quench water samples, and flue gas dust were composited. Discrete samples were obtained for flux, melter flue gas, and cooling tower water samples. Flue gas samples were taken upstream and downstream of the carbon filter. No samples were taken from the carbon filter itself, which would provide a more complete picture of the mass balance.

As for the other processes, contaminant and material losses occurring in the pre-processing step can only be estimated. Sediment was sampled for PCB analysis before and after drying in the drum dryer. However, the

mass vaporized as condensate was not determined. This mass was estimated based on the reported moisture content before and after drying. Contaminant concentrations in the condensate were also not determined.

Analytical issues

For the Holo-Flite® dryer test at Hazen, pre- and post-dryer sediment, off-gases and condensate were sampled for PCBs, dioxins and furans, SVOCs, and metals analysis. Due to problems with dust contamination of all process streams, and data inconsistency (higher concentrations were measured for some contaminants in the dried sediment than in the wet sediment), contaminant losses associated with the drying step could not be calculated. Also, PCB congeners measured in the process stream samples did not correspond to the congeners in the sediment or the congeners measured in samples from the melter test and total PCBs were not reported.

It does not appear to be explicitly specified whether contaminant concentrations reported for aqueous streams were total or dissolved concentrations. Not reported were particulate concentrations in flue gas, cooling tower water, or quench tank water. Also, some contaminants vaporized by the furnace may have been deposited on the refractory walls or the gas sampling device surfaces and were not analyzed during the relatively short-term study.

Leachate tests (SPLP and MEP) were performed on the glass aggregate product, but not on the untreated sediment. While this approach provides important information regarding beneficial use of the product, it precludes quantification of the effectiveness of the glass furnace technology in reducing leachability when compared to the untreated sediment.

Operational issues

This process involves reducing the in situ moisture content of the sediment to less than 10 percent prior to feeding to the melter. Reducing the moisture content to this level may cause the sediment to clump or produce dust. Delumping and dust control may be required. For some materials, mixing dry with wet sediment may be necessary to improve handling characteristics.

Through laboratory testing, Minergy determined that the optimum moisture content for feeding to a disk dryer was 25 percent (Minergy 2003b). Higher moisture contents are reported to cause plugging issues in commercial industrial dryers.

The glass-making process generates corrosive gases that may impact the refractory and flue gas equipment. Also, the recipe for the added flux material must be designed to optimize the viscosity and other handling characteristics of the glass product.

Minergy GFT capacity

Minergy constructed a pilot scale melter with a design capacity of 1.8 mtons (2 tons) glass aggregate/day for the SITE demonstration. The melter was fueled with natural gas (1.8 million kJ/hour (1.7 million BTU/hr)) and oxygen generated onsite (99 cu m/hr (3,500 cu ft/hr)). Dried and screened sediment was loaded into a hopper and fed into the melter at a rate of 91 kg/hour (200 lb/hr) by an auger at the bottom of the hopper. A total of (8.4m³) 11 yd³ sediment was processed in the 2001 SITE demonstration.

Based on the mass balance for the Fox River demonstration, the glass furnace melts one mass unit of sediment to produce 0.8 units of glass aggregate product. The pilot demonstration operated at a processing rate of 1.8 mtons (2 tons) per day with a dwell time in the furnace of 6 hr. The SITE report projected a full-scale plant would produce 230 mtons (250 tons) glass aggregate per day from 540 mtons (600 tons) of dredged and dewatered sediment (50% moisture). Commercially available industrial drying, sediment handling, and emission control equipment are available to support the full-scale production capacity.

Minergy GFT residuals

Residuals for this process include dryer condensate, cooling tower (scrubber) condensate and blowdown, particulates removed from the gas stream, and spent activated carbon. Drying sediment from 50% moisture to 10% moisture will produce 0.40 kg (0.89 lb) water per pound of dry sediment solids. Minergy estimates the packed tower blowdown as 0.073 kg (0.16 lb) water per pound dry sediment solids. The water streams may be treated along with water collected during the dredging and initial dewatering stages or may be sent to a wastewater treatment facility. Particulates will likely be recycled and mixed with the dryer feed to

maintain a closed loop for the dust. The quench tank water can be cooled, treated to remove particulates, and recycled to the tank to close the loop for the quenching operation.

Beneficial use product

The glass aggregate for the Fox River demonstration was characterized by total metals analyses and by two standard leaching procedures—the ASTM 1999 water leaching procedure and the SPLP. While the total metal and total PCBs were detected at relatively low levels in the product, these contaminants in dissolved form were not detected in any of the leachate samples. PCBs and metals were also non-detect for SPLP analysis on glass aggregate that had been crushed and passed through a No. 200 sieve (75 μm (1.5×10^{-5} in)).

No Federal criteria are currently available for specific regulation of the glass aggregate for reuse. However, the state of Wisconsin has established criteria for beneficial use of industrial by-products. Comparing the glass aggregate product to the criteria in Wisconsin Administrative Code, Chapter NR 538, the glass aggregate product qualifies for beneficial use under NR 538 Category 2 criteria but is subject to regulatory notification and environmental monitoring requirements (USEPA 2004). Arsenic and cadmium may require further consideration because the Wisconsin criteria are below the detection limits for these two metals.

The glass aggregate is potentially usable for construction fill, roadbed construction, concrete additives, blended cements, asphalt paving, blasting grit, ceramic floor tiles, and asphalt shingle granules. It can be stored like any quarried aggregate. Table 22 presents Minergy's assessment of the suitability of their product for several of these uses in comparison to acceptable criteria unique to each type of use.

BioGenesisSM Sediment Washing Technology mass balance

Operational description

The BioGenesisSM Sediment Washing Technology is an ambient temperature sediment treatment process. This technology is designed to remove sorbed contaminants and organic matter from inert sediment particles. BioGenesis uses a five-step treatment process to achieve particle

Table 22. Minergy Corporation glass aggregate marketing chemical and physical property analysis.

Roofing Shingle Granules	Target	Glass Aggregate	Accept?	Method
Loose Bulk Density	> 1282 kg/m ³ (> 80 lbs/ ft ³)	1442 kg/m ³ (90 lbs/ ft ³)	Yes	Weight/volume
Fe2O3 (for opacity)	> 5%	7%	Yes	ASTM 4326
Hardness	>5.5	6.2	Yes	Moh's mineral scale
Crystalline Silica content	<1%	no detect	Yes	X-Ray Diffraction
Leachability	TCLP test	passes	Yes	TCLP method 1311
Particle size	>80% between #12-#30	passes (crushed)	Yes	ASTM C136
Industrial Abrasives	Target	Glass Aggregate	Accept?	Method
Loose Bulk Density	> 1282 kg/m ³ (> 80 lbs/ ft ³)	1442 kg/m ³ (90 lbs/ ft ³)	Yes	Weight/volume
CaO	< 50%	17%	Yes	ASTM 4326
Al ₂ O ₃	< 40%	10%	Yes	ASTM 4326
Fe ₂ O ₃	< 20%	7%	Yes	ASTM 4326
Hardness	>5.5	6.2	Yes	Moh's mineral scale
Crystalline Silica content	<1%	no detect	Yes	X-Ray Diffraction
Leachability	TCLP test	passes	Yes	TCLP method 1311
Particle Size	>80% between #16-#50	passes (crushed)	Yes	ASTM C136
Embedment	<20%	7%-15%	Yes	KTA Tater Test
Ceramic Floor Tile	Target	Glass Aggregate	Accept?	Method
Loose Bulk Density	> 1282 kg/m ³ (> 80 lbs/ ft ³)	1442 kg/m ³ (90 lbs/ ft ³)	Yes	Weight/volume
Crystalline Silica content	<1%	no detect	Yes	X-Ray Diffraction
CaO	< 50%	17%	Yes	ASTM 4326
Glass Melting Point	> 2000 °F	2200 °F	Yes	ASTM 965
Particle Size	>80% between #16-#50	passes (crushed)	Yes	ASTM C136
Tile Strength	> 15 MPa (>2176 psi)	22 MPa (3191 psi)	Yes	MOR/3-E (*)
Cement Pozzolan	Target	Glass Aggregate	Accept?	Method
Particle Size	480 m ² /kg	passes (crushed)	Yes	ASTM C618
Iron-Alumo-Silicate	> 50%	52% - 60%	Yes	ASTM 114
L.O.I.	<6%	no detect	Yes	ASTM 114 ch.16
Cement Strength (3 day)	17.5 MPa (2535 psi)	19.7 MPa (2850 psi)	Yes	ASTM C311
Cement Strength (7 day)	23.9 MPa (3470 psi)	25.4 MPa (3680 psi)	Yes	ASTM C311
Cement Strength (28 day)	27.3 MPa (3953 psi)	36.5 MPa (5300 psi)	Yes	ASTM C311
Construction Fill Acceptable gradation and compaction.				

isolation and contaminant removal that includes (1) sediment screening, (2) sediment preprocessing, (3) sediment collision, (4) cavitation and oxidation, (5) solids separation, and (6) wastewater treatment. Process flow diagrams for the NY/NJ Harbor pilot scale demonstration project, the Venice pilot scale project and the full-scale NY/NJ Demonstration were provided in the section of Chapter 2 titled “BioGenesisSM Sediment Washing Technology brief.”

- Sediment screening is used to remove oversized debris typically larger than 6 mm (¼ in.). A variety of conventional screen technologies are used for this process.
- Preprocessing involves the separation of loosely associated material and oil and grease from the sediment slurry. Preprocessing involves the addition of chemical surfactants and chelating agents mixed with the raw sediment in a preprocessor mix tank, and the first application of high pressure water (69 MPa (10,000 psi)) injected through nozzles tangentially into the slurry. The purpose of the BiogenesisSM preprocessor is to thoroughly mix the washing chemicals, disaggregate clumped particles in the slurry, disaggregate the biofilm coating from the sediment particles, and transfer contaminants to water phase. The preprocessed slurry can undergo organics separation using dissolved air flotation in the BiogenesisSM aeration unit, depending on the contaminants in the sediment. Output from the preprocessor or the aeration unit is directed to the BiogenesisSM collision chamber.
- In the BiogenesisSM collision chamber, high pressure water (69 MPa (10,000 psi)) creates a renewable impact surface to which sediment slurry flow is directed perpendicular to create collision forces that further strip the biofilm layer and associated contaminants from the sediment particles and transfer them to the water phase.
- The sediments are then transferred to the cavitation/oxidation mixing tank for the purpose of oxidizing and destroying the organic contaminants and natural organic matter that have been removed from the sediment particles. For the 1999 demonstration, the sediment slurry exiting the collision chamber was sent directly to the cavitation/oxidation unit. Subsequent demonstrations, such as the Venice, Italy, demonstration, employed a hydrocyclone to separate solids, and directed the more dilute, fines slurry to the cavitation/oxidation unit.
- After the cavitation/oxidation step, the decontaminated particles are dewatered through mechanical methods, such as hydrocyclone separation and centrifugation.

- Wastewater generated by the BioGenesisSM process is then treated using conventional wastewater treatment techniques before reuse and/or discharge to a nearby wastewater treatment plant or permitted disposal to a receiving water body.

Mass balance

Results from the BioGenesisSM pilot studies were used to determine the materials mass balance throughout the pilot-scale process and the mass balance distribution of contaminants. The mass balance calculations contribute to an understanding of where treatment is occurring and the fate of the contaminants through the BioGenesisSM Sediment Washing process.¹

Material flow through the system was calculated based on feed rates for raw sediment and water in the pre-processor and collision chamber. All slurry samples were separated into solid and aqueous phases to determine the partitioning of contaminants in the solid and liquid phases after each processing step. Process streams in Figure 12 for which there were contaminant mass data available are numbered, and correspond to column headings in the complete mass balance summary provided in Appendix F. Table 23 summarizes the process streams as stage inputs and outputs, and indicates which samples were analyzed for a given contaminant. These summary tables are intended to provide sources of the information for ready reference, indicate which process streams were (or were not) accounted for, and illustrate any gaps in the chemical analysis that complicated mass balance reconstruction.

Materials mass balance

Stratus Petroleum Corporation, Newark Terminal Site, Upper Newark Bay, Lower Passaic River Newark, New Jersey (NYNJH Pilot Demonstration)

Figure 31 shows the materials mass balance for the NYNJH pilot study performed for sediments from the lower Passaic River. As shown in Appendix E-1, 6,979 kg (15,386 lb) (5.5 m³ (7.2 yd³)) of sediments (at 33.2% solids) were treated resulting in 2,271 kg (5,007 lb) of treated

¹ This would have been preferable as the 2006 demonstration represented the latest generation of the process using full-scale equipment, according to the vendor. Unfortunately, data to perform a mass balance for the 2006 full-scale demonstration project were not available in the project report.

sediments (at 69.0% solids). Approximately 7,920 kg (17,460 lb) of water were added during treatment, resulting in 12,628 kg (27,839 lb) of centrate (at 5.9% solids).

Table 23. Sampling and testing matrix for Biogenesis Venice demonstration treatment stages and process streams.

	1		2				3		4			5			6 and 7													
	Soil/Sediment Preparation (includes 6 mm vibrating screen)		Preprocessor				Collision Chamber		Primary Liquid/Solid Separation (Hydrocyclone)			Cavitation/Oxidation			Secondary Liquid/Solid Separation (Centrifuge)													
	In	Out	In	Out	In	Out	In	Out	In	Out	In	Out	In	Out														
	Rear Sediment	Clay Water	Sediment Slurry	Shells, Gravel, Debris, etc., to Landfill	Sediment Slurry	Biogenesis Chemicals	Clay Water	High Pressure Clay Water	Sediment Slurry	Preprocessor Effluent	Sediment Slurry	Clay Water	High Pressure Clay Water	Sediment Slurry	Sediment Slurry	Treated Sediment (50 to 200 Microns)	Fine Sediment Slurry	Wastewater	Fine Sediment Slurry	Hydrogen Peroxide (Oxidant)	Fine Sediment Slurry	Suspended Organic Biomass	Wastewater	Fine Sediment Slurry	Treated Fines (Centrifuge Solids)	Centrate Solids	Wastewater (Centrate)	
Contaminant Mass																												
Contaminant Concentration			Q ^{1,2} , R ^{1,2} , S ^{1,2,3,4,5}													Q ^{1,2,3,5,6} , R ^{1,2,3,4,5} , S ^{1,2,3,4,5}									Q ^{1,2,3,4,5} , R ^{1,2,3,4,5} , S ^{1,2,3,4,5}	Q ^{1,2,3,4,5} , R ^{1,2,3,4,5} , S ^{1,2,3,4,5}		
Solids Analyses																												
Solids Mass	Q, R, S, T ^{1,2}																											
Solids Process Rate	Q, R, S, T ^{1,2}																											
Percent Moisture	Q ¹	Q ^{1,2} , R ^{1,2} , S ^{1,2,3,4,5}														Q ^{1,2,3,5,6} , R ^{1,2,3,4,5} , S ^{1,2,3,4,5}									Q ^{1,2,3,4,5} , R ^{1,2,3,4,5} , S ^{1,2,3,4,5}			
Volume																												
Density	Q ¹																											
Density of Solids	Q ¹																											
Specific Gravity	S ¹ , T ¹	Q ¹ , R ¹																										
Grain Size		Q ^{1,2} , R ^{1,2} , S ^{1,2,3,4,5}														Q ^{1,2,3,5,6} , R ^{1,2,3,4,5} , S ^{1,2,3,4,5}									Q ^{1,2,3,4,5} , R ^{1,2,3,4,5} , S ^{1,2,3,4,5}	Q ² , R ⁴ , S ³		
Total Organic Carbon		Q ^{1,2} , R ^{1,2} , S ^{1,2,3,4,5}														Q ^{1,2,3,5,6} , R ^{1,2,3,4,5} , S ^{1,2,3,4,5}									Q ^{1,2,3,4,5} , R ^{1,2,3,4,5} , S ^{1,2,3,4,5}			
Total Kjeldahl Nitrogen		Q ² , R ⁴ , S ¹ , T ²																										
Phosphorus		S ¹ , T ²																										
Chlorides		S ² , T ²																										
Sulfur		S ² , T ²																										
Metals		Q ^{1,2} , R ^{1,2} , S ^{1,2,3,4,5}														Q ^{1,2,3,5,6} , R ^{1,2,3,4,5} , S ^{1,2,3,4,5}									Q ^{1,2,3,4,5} , R ^{1,2,3,4,5} , S ^{1,2,3,4,5}			
PAHs		Q ^{1,2} , R ^{1,2} , S ^{1,2,3,4,5}														Q ^{1,2,3,5,6} , R ^{1,2,3,4,5} , S ^{1,2,3,4,5}									Q ^{1,2,3,4,5} , R ^{1,2,3,4,5} , S ^{1,2,3,4,5}			
Total Hydrocarbons		Q ^{1,2} , R ^{1,2} , S ^{1,2,3,4,5}														Q ^{1,2,3,5,6} , R ^{1,2,3,4,5} , S ^{1,2,3,4,5} , T ^{1,2,4,5}									Q ^{1,2,3,4,5} , R ^{1,2,3,4,5} , S ^{1,2,3,4,5}			
Organic Pesticides		S*														S												
PCBs		S														S												
Dioxins/Furans		S ²														S ²												
Liquid Analyses																												
Water Mass																												
Volume																												
TSS																												
IDS																												
TOC																												
BOD																												
COD																												
Total Kjeldahl Nitrogen																												
Ammonia																												
Total Phosphorus																												
Sulfur																												
Total Hydrocarbons																												
Anions																												
Cations																												
Metals																												
PAHs																												
Aromatic Organics																												
Nonhalogenated Organics																												
Nitrobenzene																												
Chlorobenzene																												
Halogenated Organics																												
Phenols																												
Aromatic Amines																												
PCBs																												
Dioxins/Furans																												

Q Venice Study Batch 1 (PC4 - Molo Sali)
R Venice Study Batch 2 (PC2 - Canale Industriale Ovest (Upper Reach))
S Venice Study Batch 3 (PC3 - Canal Industriale Nord)
T Venice Study Batch 4 (PC1 - Canal Industriale Ovest (Lower Reach))

¹ Includes measurements for first run
² Includes measurements for second run
³ Includes measurements for third run
⁴ Includes measurements for fourth run
⁵ Includes measurements for fifth run
* Where no numbers indicating run are present, it can be assumed that all runs were analysed for the batch/analysis

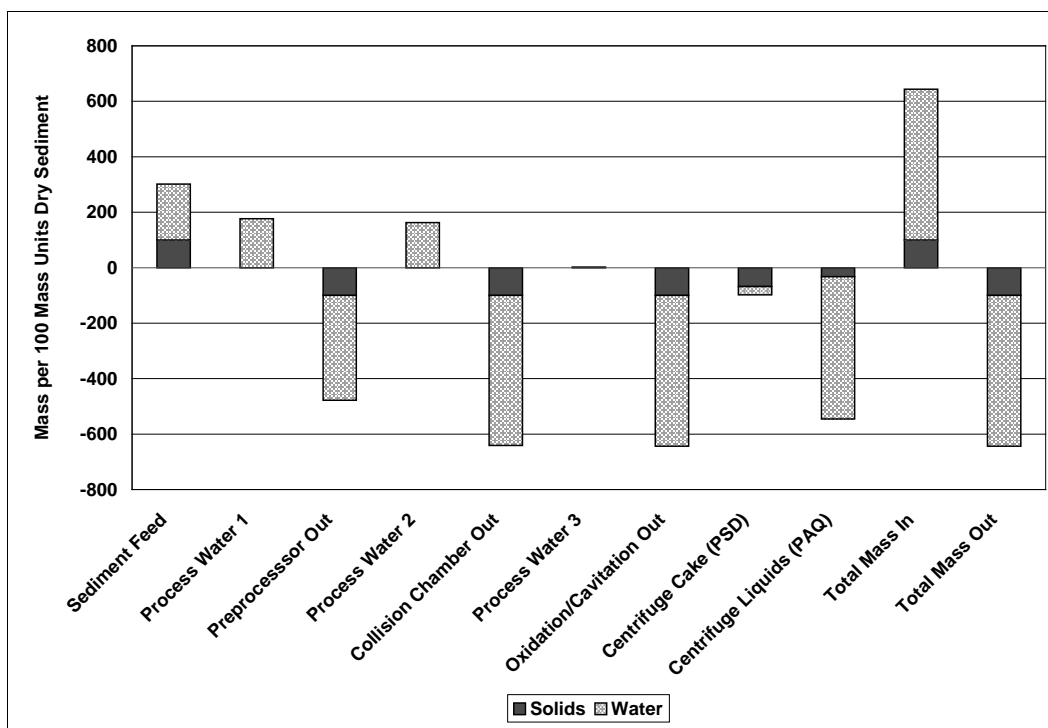

Figure 31. BioGenesisSM materials balance for NYNJ pilot demonstration.

Porto Marghera, Venice, Italy (Venice Pilot Demonstration)

The Venice pilot demonstration evaluated the BioGenesisSM process for sediments from four locations in the canals of Porto Marghera. Four sediments identified as PC1, PC2, PC3, and PC4 were selected to represent the range of contamination and sediment types in the canal. Figure 32 illustrates the materials balance for each of the four sediments. From 18,000 to 36,000 kg (40,000 to 80,000 lb) of sediment were treated for each validation run as shown in the mass balance found in Appendix F. The solids concentration for the sediment slurry feed ranged from 26% to 31% solids. The addition of process water increased the wastewater mass leaving the system by 42% of the sediment feed mass. Approximately two thirds of the sediment feed solids reported to the centrifuge cake; however, the total centrate mass (solids and water) was more than five times the mass of the centrifuge cake.

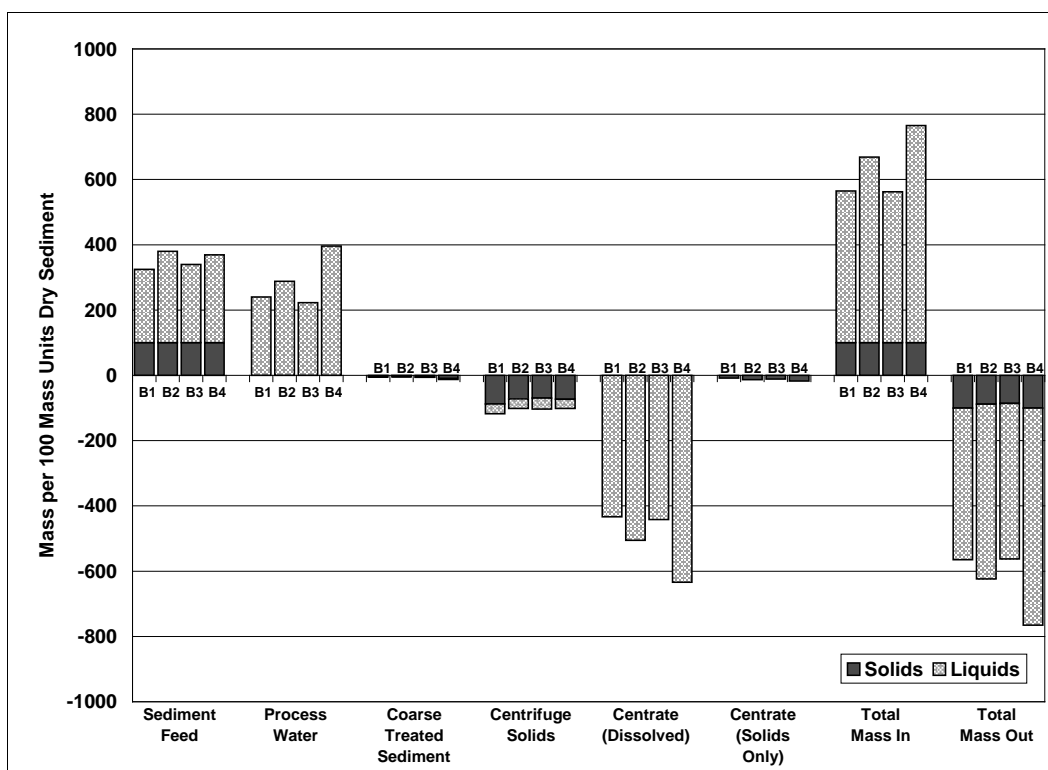

Figure 32. Materials mass balance for Venice sediments (Numbers 1-4 indicate four batches, each from a different site).

Contaminant mass balance

Tables 24, 25, and 26 summarize the process streams as stage inputs and outputs for the NYNJH Pilot demonstration and indicate which samples were analyzed for a given contaminant. These summary tables are intended to provide sources of information for ready reference, indicate which process streams were (or were not) accounted for, and illustrate any gaps in the chemical analysis that complicated mass balance reconstruction.

NYNJH Pilot Demonstration

As introduced in the section of Chapter 2 titled “Performance,” the contaminant mass balance data for the BioGenesisSM Sediment Washing Technology at the NYNJ Harbor pilot demonstration (BioGenesis Interprises, Inc., and Roy F. Weston, Inc. 1999) indicated a relatively complete mass balance for total metals entering and exiting the system.

Table 24. Sampling and testing matrix for Biogenesis NYNJH Pilot (part 1 of 3).

Parameter	Soil/Sediment Preparation (Shaker Screens ^{a,d})		Attrition Scrubbing/Aeration						Preprocessor		Hydrocyclone			Mix Tank							
	In	Out	In			Out			In	Out	In	Out	In	Out							
	Untreated Soil/Sediment	Untreated Soil/Sediment (Fines)	Untreated Soil/Sediment (Retained)	Waste Organics	Untreated Soil/Sediment (Retained)	BGE Washing Chemical	Air	Water	Treated Soil/Sediment (Retained)	Wastewater	Untreated Soil/Sediment (Fines)	Wash Water (10,000 psi)	Soil/Sediment (Fines)	Soil/Sediment (Fines)	Wash Water from Preprocessor	Soil/Sediment (Fines)	Wastewater	Soil/Sediment (Fines)	BGE Washing Chemical	Soil/Sediment (Fines)	
Solids Mass Data?	X*,Y,Z			Y,Z																	
Water Mass Data?	X,Y,Z			Y,Z																	
Volume Data?	X,Y,Z																				
Percent Moisture Data?	X,Y,Z			Y,Z																	
Grain Size Data?	X,Y,Z			Y ^I																	
Contaminant Mass Data?	X,Y,Z			Y,Z																	
Contaminant Conc Data?	X,Y,Z			Y,Z																	
Metals																					
PCBs	X,Y,Z			Y,Z																	
PCB Congeners	X ^I ,Y,Z ^I																				
SVOCs																					
PCDD/DFs	X ^I ,Y,Z ^I																				
Pesticides																					
TOC	X,Y,Z			Y,Z																	
TSS																					
TDS																					

^a Shaker screen sizes for retaining untreated soil/sediment (TS-SED-A) were 6.25 mm and 425 micron
^b Shaker screen size for retaining fines (TS-SED-A) was 75 micron
^c Shaker screen size for retaining extra fines (TS-SED-A, TS-SED-B, TS-SO-A) was 37 micron
^d Shaker screen size for retaining untreated soil/sediment (TS-SED-B and TS-SO-A) was 850 micron
^I Includes measurements for first run
^{II} Includes measurements for second run
^{III} Includes measurements for third run
X Measurements for coarse-grained material (TS-SED-A)
Y Measurements for fine-grained material (TS-SED-B)
Z Measurements for floodplain soils (TS-SO-A)
* If there is no numeral indicator of the runs for a particular input and parameter, the parameter was measured for all runs for that soil type

Table 25. Sampling and testing matrix for Biogenesis NYNJH Pilot (part 2 of 3).

Parameter	Preprocessor			Collision Chamber				Cavitation/Oxidation			Shaker Screen (if Applicable ^b)			Hydrocyclone			
	In		Out	In		Out		In		Out	In		Out				
	Soil/Sediment (Fines)	Wash Water (10,000 psi)	Re-cycled Soil/Sediment (Except First Cycle)	Soil/Sediment (Fines)	Wash Water (10,000 psi)	Soil/Sediment (Fines)	Soil/Sediment (Aqueous Phase)	Soil/Sediment (Fines)	Hydrogen Peroxide	Soil/Sediment (Fines)	Soil/Sediment (Fines)	First Cycle Treated Soil/Sediment (Retained Fines)	Second Cycle Treated Soil/Sediment (Retained Fines)	Soil/Sediment (Extra Fines)	Soil/Sediment (Extra Fines)	Soil/Sediment (Extra Fines)	Wastewater
Solids Mass Data?												X	X				
Water Mass Data?												X	X				
Volume Data?																	
Percent Moisture Data?												X	X				
Grain Size Data?						X ^{i,ii} ,Y ^{ii,iii} ,Z						X ⁱ					
Contaminant Mass Data?						X,Y,Z	X,Y,Z					X	X				
Contaminant Conc Data?						X,Y,Z	X,Y,Z					X	X				
Metals																	
PCBs						X,Y,Z	X,Y,Z					X	X				
PCB Congeners																	
SVOCs																	
PCDD/DFs																	
Pesticides																	
TOC						X,Y,Z	X,Y,Z					X	X				
TSS							X,Y,Z										
TDS							X,Y,Z										

^a Shaker screen sizes for retaining untreated soil/sediment (TS-SED-A) were 6.25 mm and 425 micron

^b Shaker screen size for retaining fines (TS-SED-A) was 75 micron

^c Shaker screen size for retaining extra fines (TS-SED-A, TS-SED-B, TS-SO-A) was 37 micron

^d Shaker screen size for retaining untreated soil/sediment (TS-SED-B and TS-SO-A) was 850 micron

ⁱ Includes measurements for first run

ⁱⁱ Includes measurements for second run

ⁱⁱⁱ Includes measurements for third run

X Measurements for coarse-grained material (TS-SED-A)

Y Measurements for fine-grained material (TS-SED-B)

Z Measurements for floodplain soils (TS-SO-A)

* If there is no numeral indicator of the runs for a particular input and parameter, the parameter was measured for all runs for that soil type

Table 26. Sampling and testing matrix for Biogenesis NYNJH Pilot (part 3 of 3).

Parameter	Shaker Screen ^c				Centrifuge				Treated Solids				Wastewater Holding Tank	Rinse Water
	In	Out			In	Out			In				In	
	Soil/Sediment (Extra Fines)	Soil/Sediment (Passing Extra Fines)	First Cycle Treated Soil/Sediment (Retained Extra Fines)	Second Cycle Treated Soil/Sediment (Retained Extra Fines)	Soil/Sediment (Passing Extra Fines)	First Cycle Treated Soil/Sediment (Passing Extra Fines)	Second Cycle Treated Soil/Sediment (Passing Extra Fines)	Wastewater	Treated Soil/Sediment (Retained)	Third Cycle Treated Soil/Sediment (Retained Fines)	Third Cycle Treated Soil/Sediment (Retained Extra Fines)	Third Cycle Treated Soil/Sediment (Passing Extra Fines)	Wastewater from Aeration, Hydrocyclones, Centrifuge	Rinse Water
Solids Mass Data?			X,Y,Z	X,Y,Z		X,Y,Z	X,Y,Z		X	X	X,Y,Z	X,Y,Z	X,Y,Z	
Water Mass Data?			X,Y,Z	X,Y,Z		X,Y,Z	X,Y,Z		X	X	X,Y,Z	X,Y,Z		
Volume Data?													X,Y,Z	
Percent Moisture Data?			X,Y,Z	X,Y,Z		X,Y,Z	X,Y,Z		X	X	X,Y,Z	X,Y,Z		
Grain Size Data?			Y,Z ^l			X ^l ,Y ^l ,Z			X ^{l,II}	X	X,Y,Z ^l	X,Y,Z ^l		
Contaminant Mass Data?			X,Y,Z	X,Y,Z		X,Y,Z	X,Y,Z		X	X	X,Y,Z	X,Y,Z	X,Y,Z	
Contaminant Conc Data?			X,Y,Z	X,Y,Z		X,Y,Z	X,Y,Z		X	X	X,Y,Z	X,Y,Z	X,Y,Z	X,Y,Z
Metals														
PCBs			X,Y,Z	X,Y,Z		X,Y,Z	X,Y,Z		X	X	X,Y,Z	X,Y,Z	X,Y,Z	X,Y,Z
PCB Congeners			Z							X	Y			
SVOCs														
PCDD/DFs			Z							X ^I	X ^{III} ,Y ^{III}			
Pesticides														
TOC			X,Y,Z	X,Y,Z		X,Y,Z	X,Y,Z		X	X	X,Y,Z	X,Y,Z	X,Y,Z	
TSS													X,Y,Z	X,Y,Z
TDS													X,Y,Z	X,Y,Z

^a Shaker screen sizes for retaining untreated soil/sediment (TS-SED-A) were 6.25 mm and 425 micron

^b Shaker screen size for retaining fines (TS-SED-A) was 75 micron

^c Shaker screen size for retaining extra fines (TS-SED-A, TS-SED-B, TS-SO-A) was 37 micron

^d Shaker screen size for retaining untreated soil/sediment (TS-SED-B and TS-SO-A) was 850 micron

^l Includes measurements for first run

^{II} Includes measurements for second run

^{III} Includes measurements for third run

X Measurements for coarse-grained material (TS-SED-A)

Y Measurements for fine-grained material (TS-SED-B)

Z Measurements for floodplain soils (TS-SO-A)

* If there is no numeral indicator of the runs for a particular input and parameter, the parameter was measured for all runs for that soil type

Appendix E-1 shows more than 89% recovery for arsenic, beryllium, cadmium copper, chromium, lead, nickel, selenium, silver, and thallium. However, only 60% of the mercury and 77 % of the zinc was accounted for in the output streams. Metals mass measured in the centrifuge cake ranged from 5% of the mass entering the system for mercury to 59% for thallium with a median value of 29% for the metals evaluated. Approximately 62% of the total metals reported to the centrate, a waste stream subject to follow-on treatment.

Mercury unaccounted for was most likely attributable to volatilization. Mercury is much more volatile than most divalent metals, and can volatilize in organic (i.e., methylated) or inorganic states. With the exception of mercury, most metals reduction appears to be associated with particle separation, resulting in a redistribution of particulate associated metals mass to the aqueous waste stream (rather than solubilization). This is supported by the elevated mass of metals in the centrate solids as compared to the mass in the raw and treated sediment solids. Figures 33 and 34 show the mass balance calculation for copper and lead, representative metal cations. These graphs illustrate the much larger copper and lead masses reporting to the centrate, compared to the centrifuge cake.

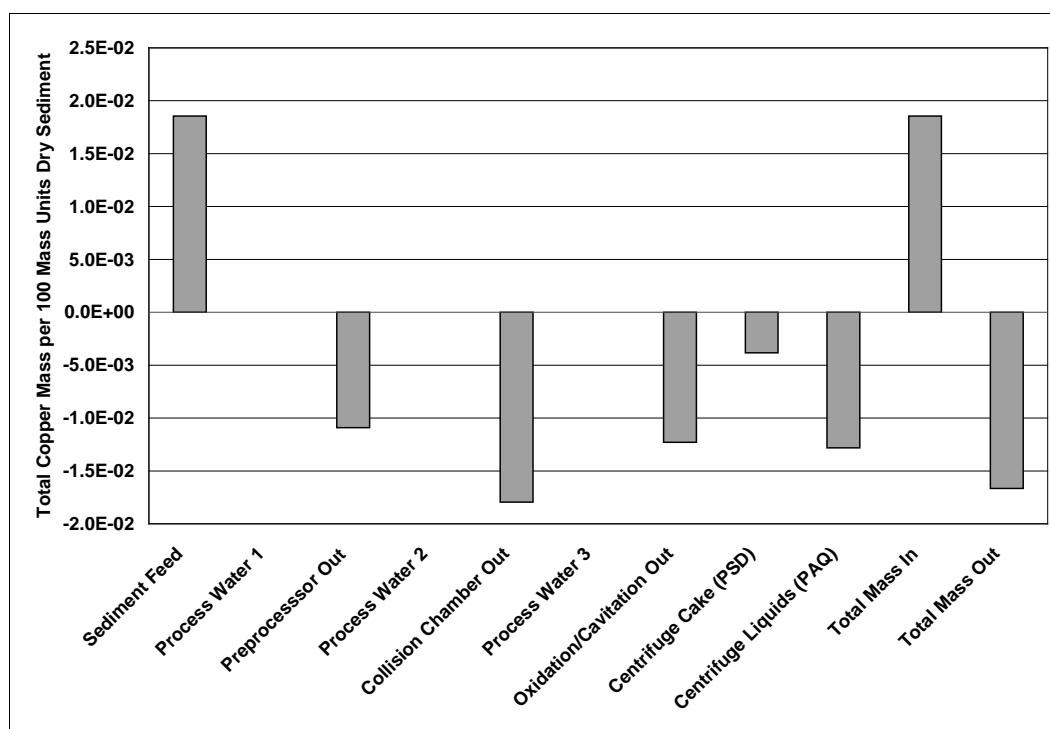

Figure 33. Fate of total copper in BioGenesisSM process for NYNY Harbor (1999 pilot).

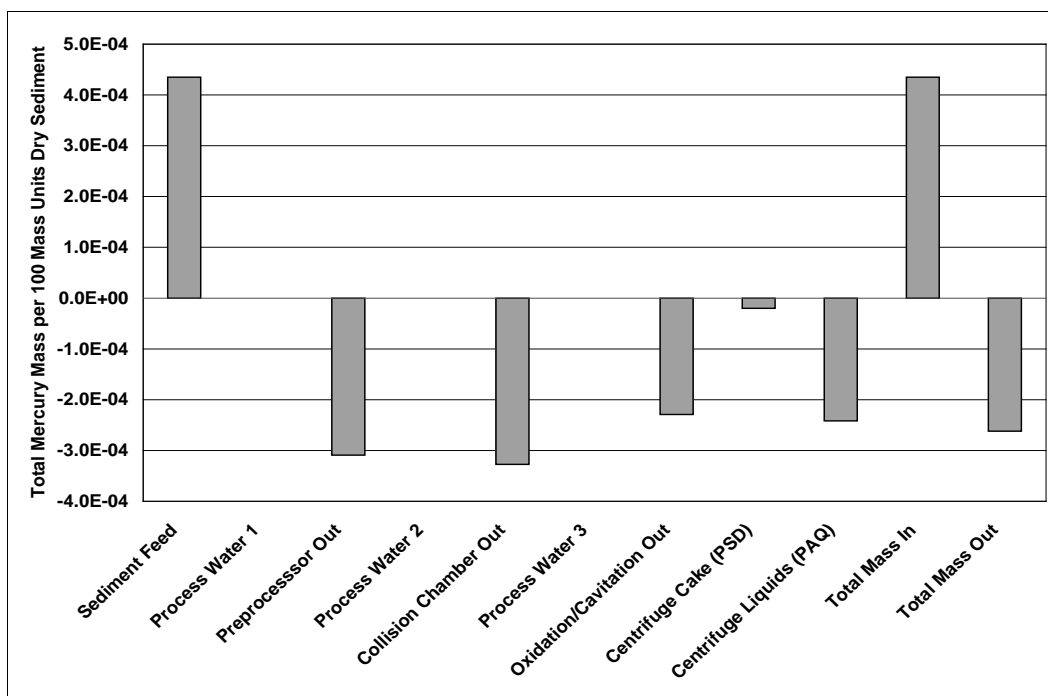

Figure 34. Fate of total mercury in BioGenesisSM process for NYNY Harbor (1999 pilot).

Of the inlet mass for the PAH compound fluoranthene, 49% was recovered in the outlet as seen in Figure 35. The unaccounted for PAH mass appears attributable to volatilization rather than destruction, based on sediment samples taken following various unit operations within the system during the 1999 study. Figure 35 shows the mass present in the output from each unit process. Almost all of the mass reduction of fluoranthene appears to occur either in the feeding step or in the pre-processor. The fluoranthene mass leaving the collision chamber and the mass leaving the cavitation/oxidation unit differs by less than 10%, and the mass leaving these two unit operations is actually slightly higher than that leaving the pre-processor. While this can possibly be attributed to material variability, it clearly does not demonstrate significant fluoranthene reduction occurring in these stages. Looking at the total PAH distribution for the various process streams in Figure 36 leads to a similar conclusion.

In the pre-processor, a mixture of chemicals and physical action disaggregates sediment particles and coatings such as natural organic matter and possibly oil and grease, which become suspended in the sediment slurry. An aeration unit is then used to remove “floatables.” The PAH concentration data clearly show that the major reduction in sediment concentrations occurs at this stage. If the preprocessor is a closed system preventing volatilization, the losses may have occurred during the feeding step or the preprocessor mix tank.

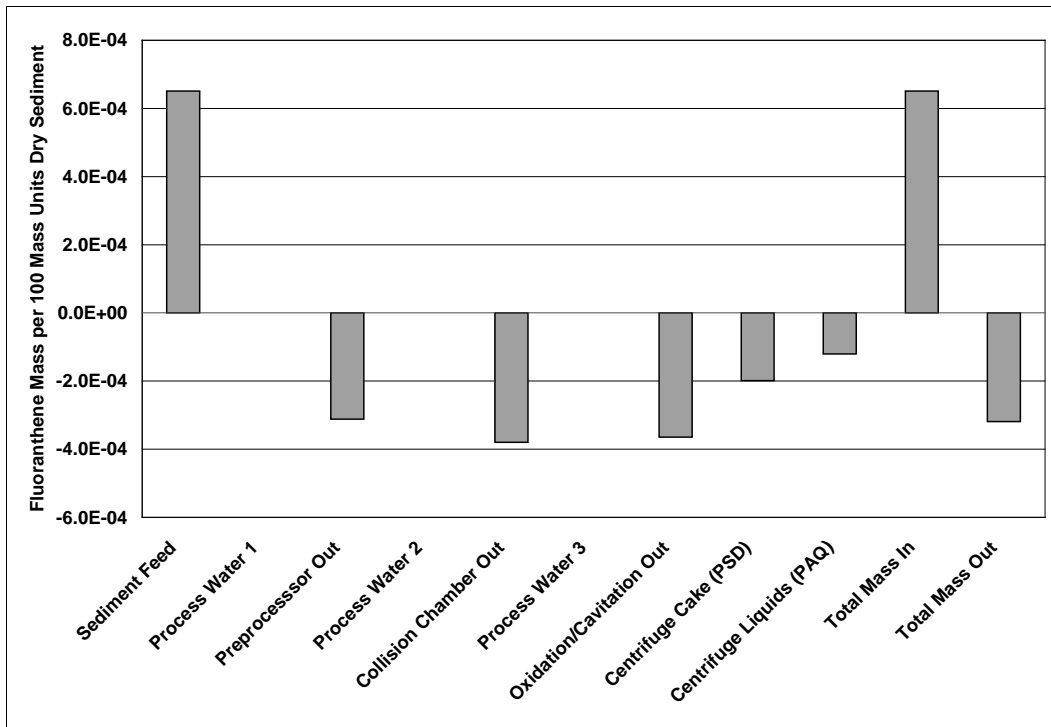

Figure 35. Fate of fluoranthene in BioGenesisSM process for NYNY Harbor (1999 pilot).

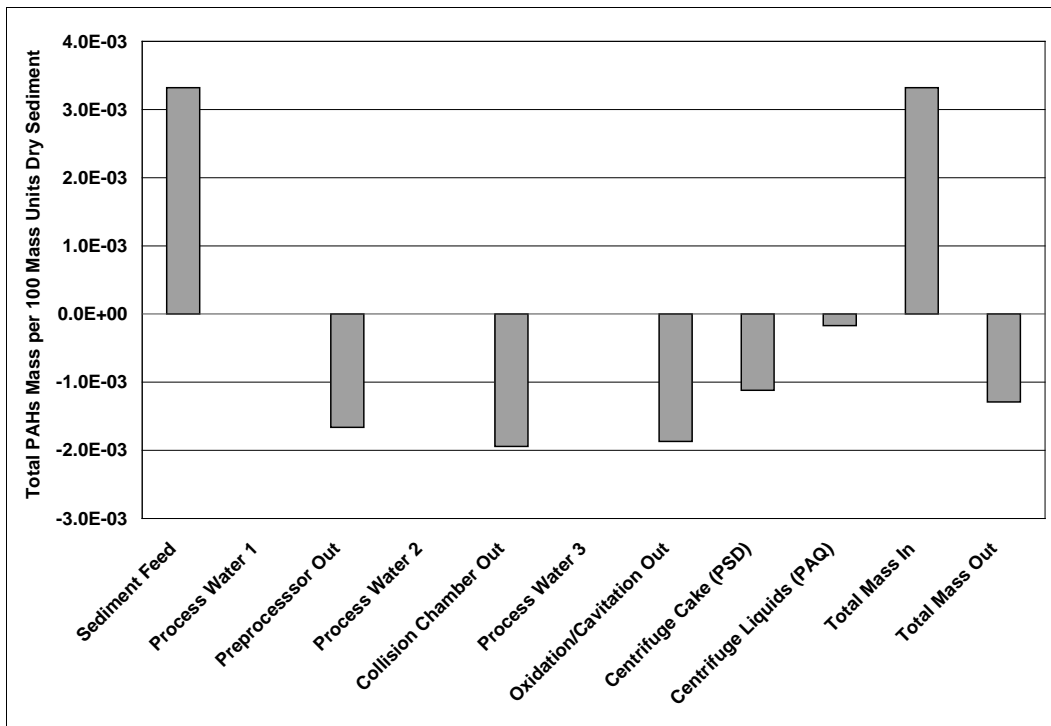

Figure 36. Fate of total PAHs in BioGenesisSM process for NYNY Harbor (1999 pilot).

One likely reason for the limited PAH destruction by chemical oxidation is that PAHs and other organic carbon contaminants represent a relatively small fraction of the total organic carbon in the feed mixture. Oxidants, like hydrogen peroxide, oxidize the full range of organic carbon indiscriminately, and preferentially oxidize the most soluble and labile forms of carbon first. In the absence of a carbon balance, predicting where the oxidative potential was being spent within the oxidation/cavitation unit is difficult, but the data clearly do not indicate oxidation of PAHs.

Venice Pilot Demonstration

Contaminant data for individual unit operations were also collected during the Venice pilot project. Contaminant concentrations were measured in the raw untreated sediment, the treated sediment from the hydrocyclone, where coarser material (sand and fine sand) was removed prior to cavitation/oxidation, and treated sediment from the centrifuge, which typically consisted of silt and some clay. The mass balance calculations and results for the Venice pilot project are presented in Appendix F. The data for this discussion were extracted from the project report (BioGenesis Italia, LLC, et al. 2005). As mentioned in the materials section, the project evaluated sediment from four locations in the port. The pilot study data were labeled by process batch: Batch 1 for sediment PC4, Batch 2 for PC2, Batch 3 for PC3, and Batch 4 for PC1. Contaminant mass balance results for the Venice demonstration are illustrated in Figures 37 through 43.

Figure 37 shows the fate of arsenic in the various BioGenesisSM process streams. The calculations for Batches 1 and 2 accounted for more than 90% of the sediment feed arsenic mass in the process output streams. However, Batches 3 and 4 found more arsenic in the output streams than the feed (10 times more for Batch 4). The increased arsenic mass may be due to analytical or sampling errors, but the cause is difficult to discern. Less than 2% of the arsenic mass reported to the hydrocyclone underflow. About half of the arsenic mass was measured in the centrate solids, and most of the remainder was in the centrifuge cake.

Figure 38 illustrates that the mass balance for lead closed well for Batches 1, 2, and 3, but Batch 4 output was more than 10 times the input. Unlike the other metals reported, a significant fraction of the lead mass was found in the centrate dissolved fraction. Zinc behaved similarly to lead in this regard. The remainder of the lead reported to the centrifuge cake.

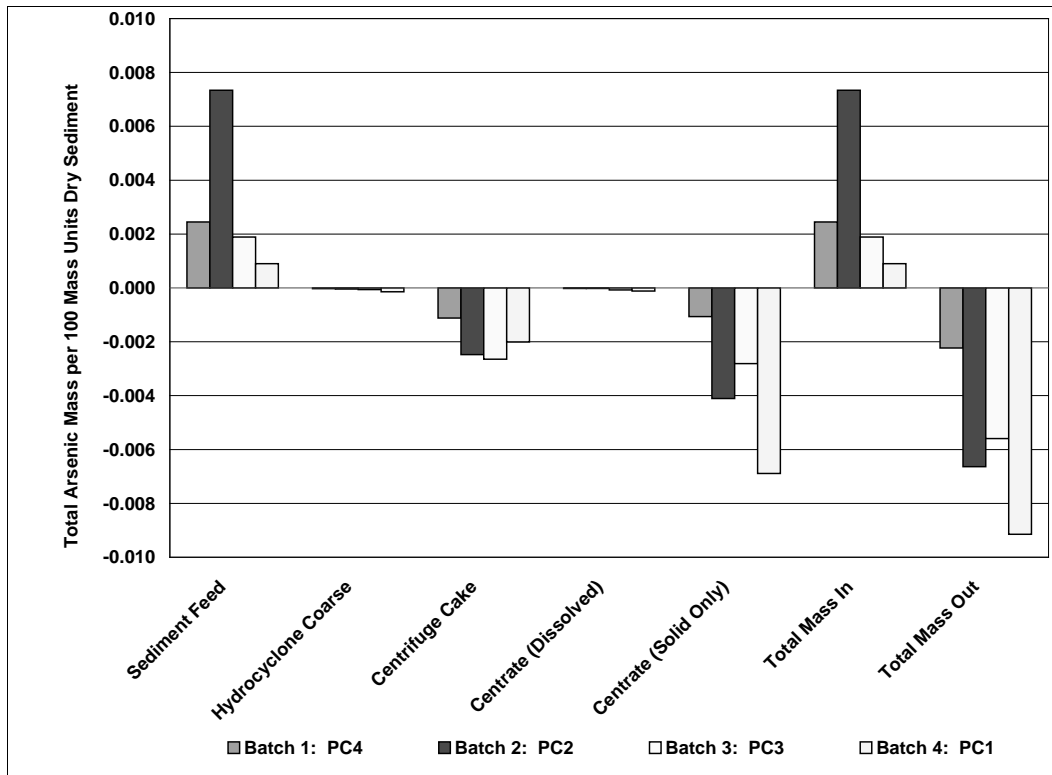

Figure 37. Fate of total arsenic in BioGenesisSM process for Venice sediments.

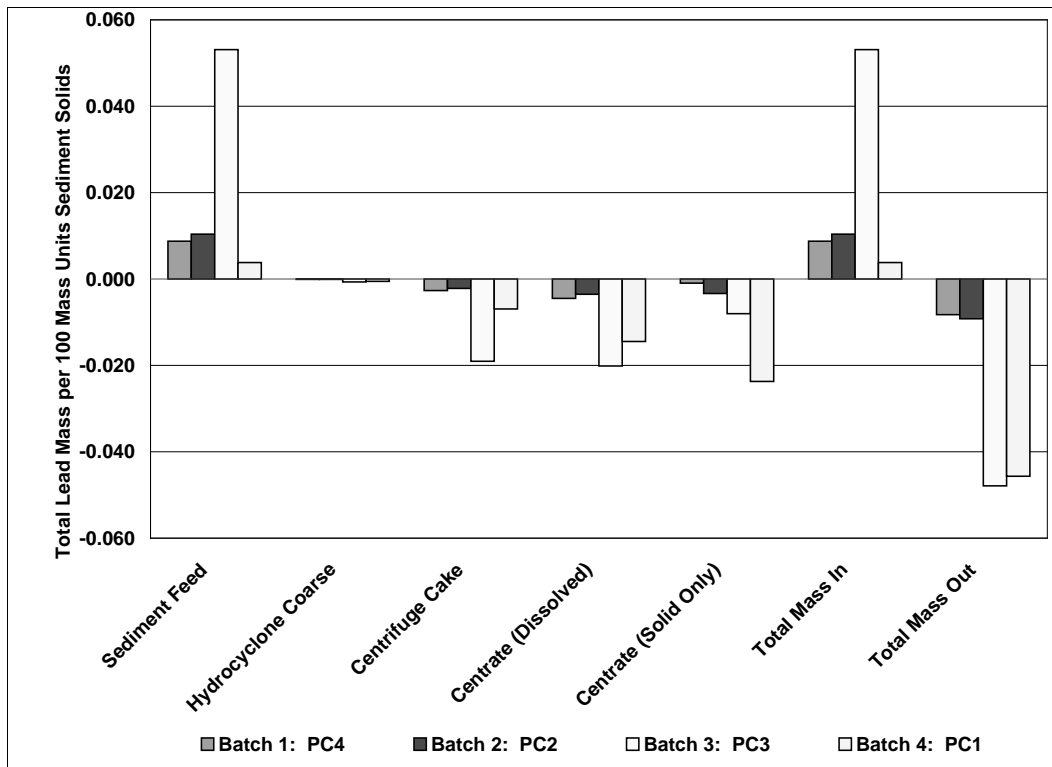

Figure 38. Fate of total lead in BioGenesisSM process for Venice sediments.

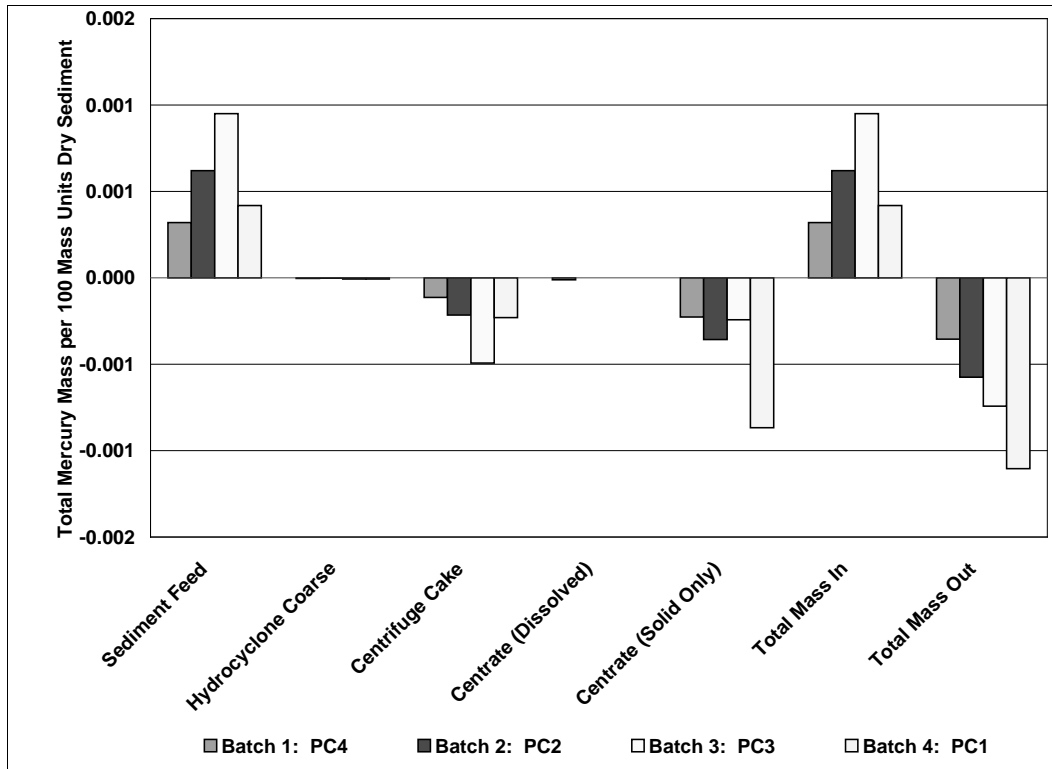

Figure 39. Fate of total mercury in BioGenesisSM process for Venice sediments.

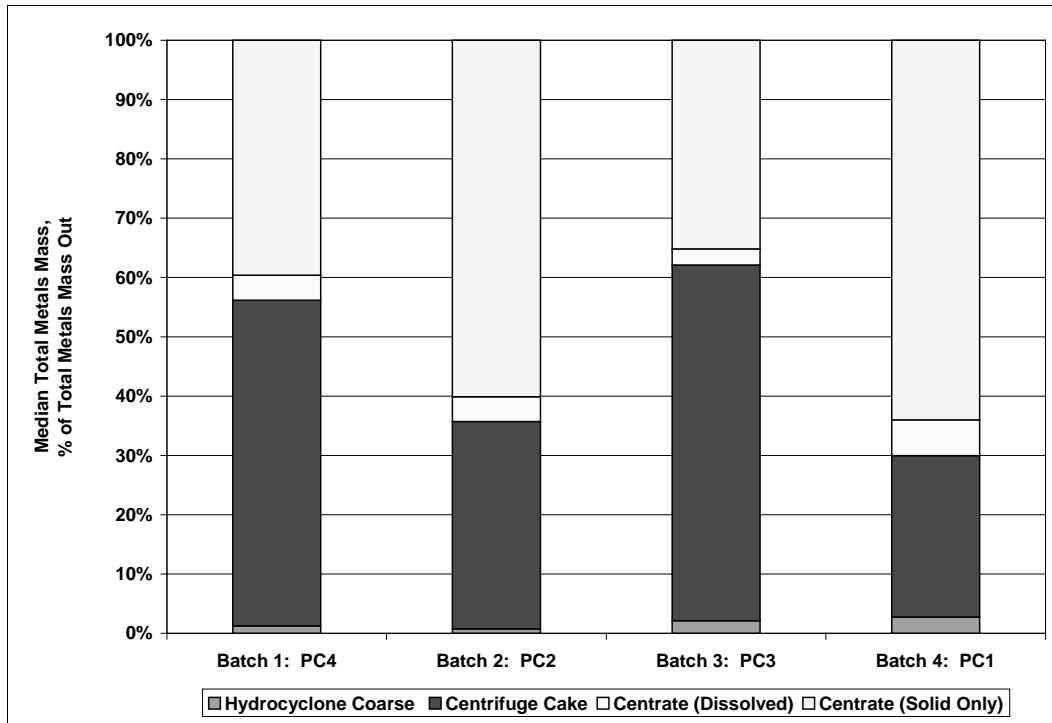

Figure 40. Total metals fate for four Venice sediments.

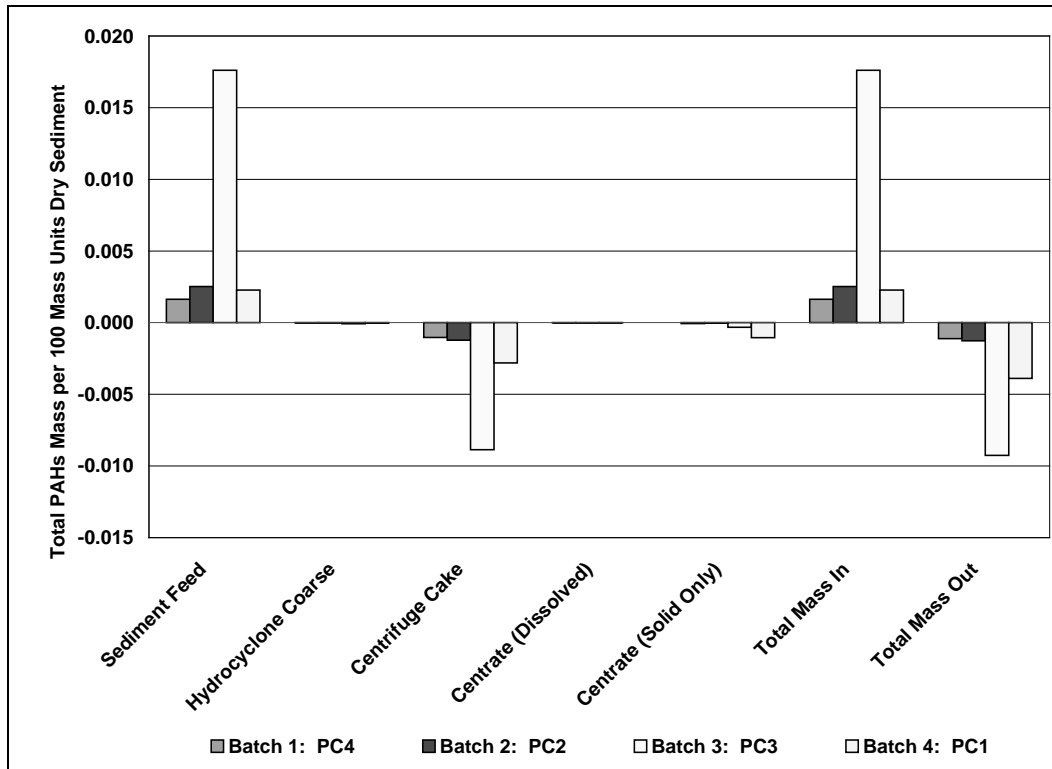

Figure 41. Fate of total PAHs in BioGenesisSM process for Venice sediments.

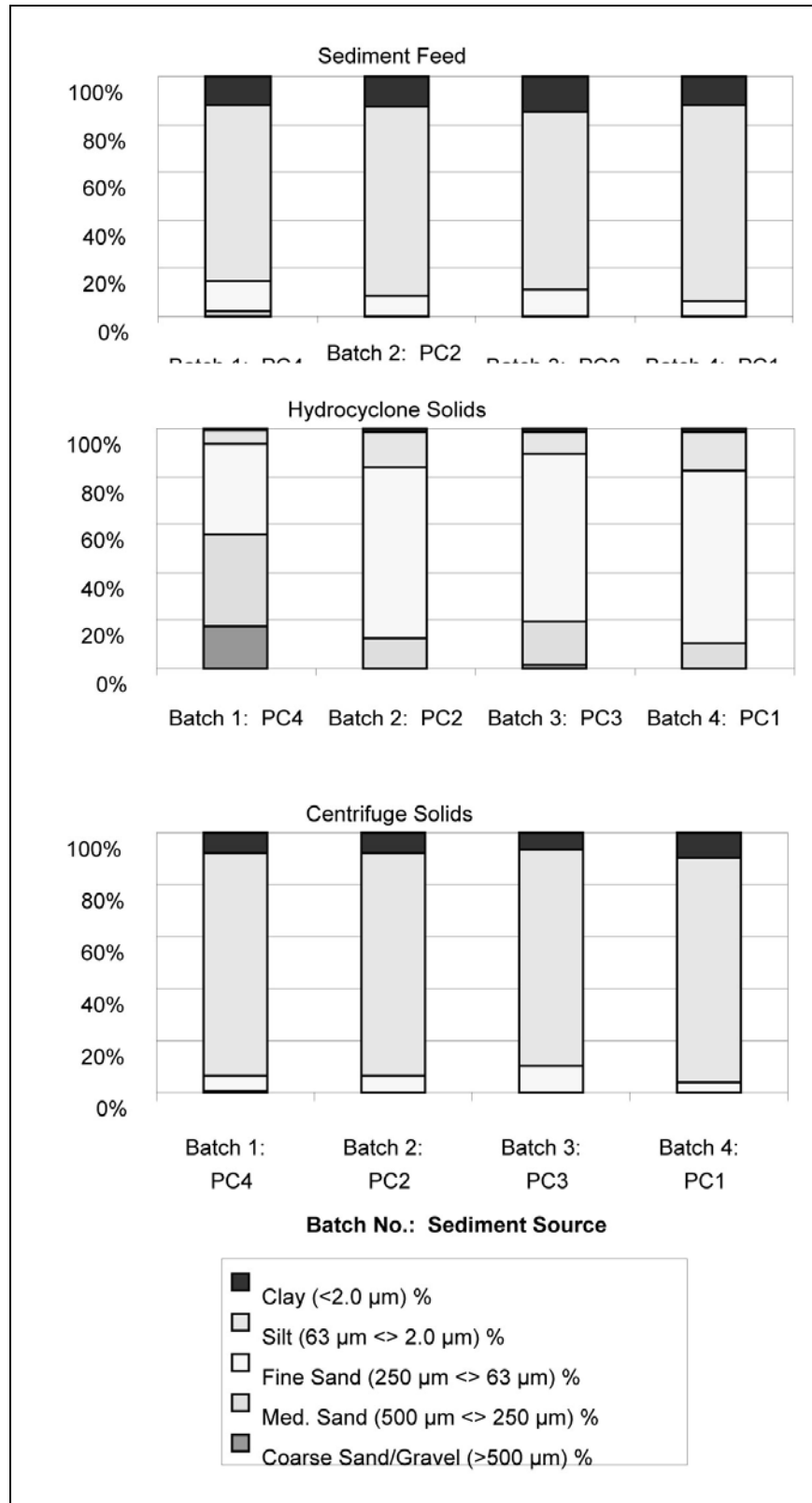

Figure 42. Grain size distribution in feed and product streams for four Venice sediments

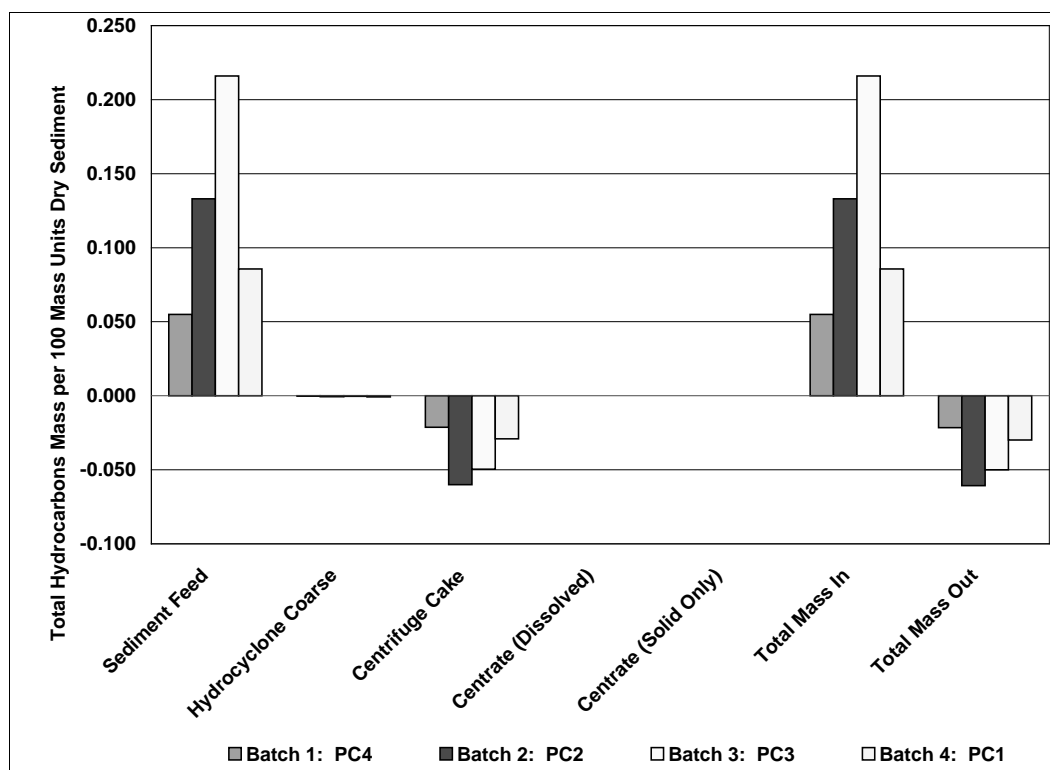

Figure 43. Fate of total hydrocarbons in BioGenesisSM process for Venice sediments.

The mass balance for mercury is illustrated in Figure 39. The largest fractions of mercury appeared in the centrate solids followed by the centrifuge cake. Only for Batch 3 was mercury lost in output streams compared to the input (22% lost).

Figure 40 presents a picture of the fate for the total metals reported for the Venice project. The median value for the fraction of metals reporting to each output stream is shown. Most of the metals mass was found in the centrifuge cake and the centrate solids. The hydrocyclone underflow (coarse fraction) was less than 2% of the total output mass, and the centrate dissolved fraction was less than 6% of the total output mass. This demonstrates that in part contaminant reduction is achieved through a particle separation effect rather than contaminant transfer to the aqueous phase, and that this may have implications regarding the difficulty and cost to manage that wastewater, depending upon available disposal options and solids concentrations.

Figures 41 and 42 show the distribution of total PAHs among the process streams. Approximately half of the PAHs disappeared in the BioGenesisSM process for the first three batches. Again Batch 4 indicated that PAHs

increased during processing. In this demonstration, the first point of measurement for the primary process stream is the centrifuge following the cavitation/oxidation unit. Whether the mixing and scrubbing steps prior to the cavitation/oxidation unit caused the PAHs to volatilize as suggested for the NYNJH project cannot be determined. Also, because samples of the fines immediately upstream of the oxidation unit were not collected, the degree of reduction attributable to the oxidation step could not be determined. The mass of total hydrocarbons, as shown in Figure 43, decreased by 23-46% during the process for all four sediments. Essentially all of the residual hydrocarbons were found in the centrifuge cake.

Figure 42 provides information regarding the particle size distribution for each of the four sediments from the original sediment feed to the hydrocyclone underflow to the centrifuge cake. The original distributions for the four sediments were similar. As expected, the hydrocyclone underflow consisted of predominantly (90%) sand and the centrifuge solids were predominantly silt and clay (90%). Data were not available for the concentrate solids, but these solids are expected to be even smaller fine-grained materials.

Passaic River Bench Testing

Additional bench testing was done on Passaic River sediments (Biogenesis Washing BGW, LLC, and MHW Americas, Inc. 2009) to improve removal of PAH-contaminated detritus from the treated sediments. The detritus, which is relatively amorphous, was not effectively removed by the hydrocyclones. The impact of adjustments to washing chemicals, addition of a wetting agent, pH and temperature adjustment, and flotation was evaluated in a series of bench tests. In the most successful test, micro-flotation was used following three processing cycles consisting of pre-processing, collision/impact, cavitation/oxidation and solid/liquid separation using hydrocyclones. PAH concentrations in the treated sediment were approximately 52 percent of concentrations in the incoming sediment. The process was successful in separating a concentrated detritus fraction with PAH concentrations approximately 329% that of the incoming sediment. Whether flotation would be successful in removing a coarse condensed carbon phase has not been tested but is another processing challenge that can be expected with some sediments. Additional process modifications, such as an upflow separator, might be required in such cases.

Housatonic Rest of the River Bench Study

BioGenesis 2008 also conducted an evaluation of its process for Housatonic River sediments, a remediation project. Since the experiments were limited to bench scale ($< 0.21 \text{ m}^3$ ($< 55 \text{ gal.}$)), this project was not evaluated in detail. Briefly, treatment efficiencies for PCBs were evaluated for three different sediment types: coarse-grained, fine-grained sediment, and floodplain soil. The combined output solids contained less than 10% of the input PCB mass. Approximately 41% of the inlet PCB mass from the treated coarse-grain sediment was measured in the effluent wastewater, and 50% of the mass was either unaccounted for or destroyed. During the treatment of the fine-grain sediment and floodplain soil, approximately 74% and 92% of the initial PCB mass was destroyed or unaccounted for, respectively.

Contaminant mass balance summary

The purpose of the BioGenesisSM process is to improve sediment treatment efficiencies compared to the traditional sediment washing technology, by enhancing the separation of fine particles, stripping the biofilm layer from the solids and transferring it to the aqueous phase, and oxidizing organic contaminants. However, from the 1999 pilot study, the data collected following each treatment process show that almost all of the PAH concentration reduction occurs between the sediment feed and the outlet from the first stage of the sediment washing process, the pre-processor, and very little or no additional reduction occurs in the subsequent treatment steps, including the collision chamber and the cavitation/oxidation system.

Technical issues

Mass balance issues

During the 1999 NYNJH pilot study, contaminant concentrations were measured in most of the waste streams. However, contaminant concentrations were not reported for the granular activated carbon, which was used to treat the air bubbled through the sediment slurry in the aeration unit and the fugitive gas emissions from holding tanks and processing vessels. Thus, it was not possible to include these process streams in the mass balance calculation, and any contaminant mass associated with the granular activated carbon was reported as “destroyed or unaccounted for.”

Analytical issues

Sample analysis and reporting for the BioGenesisSM Sediment Washing Technology followed standard analytical methods, laboratory QA/QC plan, and QAPP established for the pilot project. During the 1999 NYNJH pilot project, some PAH samples were analyzed at a dilution due to the concentration of target compounds. As a result of the dilution, some sample surrogates, spikes, and RPDs were out of acceptable limits, but these data were accepted for the use of evaluating performance of individual processing steps.

Operational issues

During the 1999 NYNJH pilot study, high-pressure nozzle tips in the pre-processor failed after only a few hours of operation. The problem was resolved by installing a one-micron filter upstream of the water blasters, which removed fine particles and reduced the internal wearing of the nozzle tips.

Analytical results for the samples collected from the aeration unit in the 1999 NYNJH study showed no floatable organics were recovered in this treatment process, and changes to the aeration time did not increase the presence of floatable organics. It was concluded that aeration was not needed for the pilot dredged material from the NYNJH, but that future operations may include an aeration step as a method for removing floatable organic matter.

During the pilot demonstration study in Venice, Italy, it was observed that the preprocessor caused enough turbulence in the slurry stream to introduce small bubbles or foam into the slurry. This sometimes caused the flowmeter displays on the unit to stop working and may have been the cause of inconsistent operation of the cavitation-oxidation unit during the pilot test. In addition, the presence of foam in the effluent water from the centrifuge would sometimes cause overflow to the discharge sump or airlock the effluent wastewater pump. However, the use of non-foaming cleaning chemicals was shown to significantly reduce the creation of foam during the cleaning, which improved the performance of the flow meters, the cavitation-oxidation unit, and the centrifuge.

BioGenesisSM capacity

As initially discussed in the section in Chapter 2 titled “Incidental contaminant reduction and losses,” 540 m³ (700 yd³) of dredged material was used for the pilot demonstration of the BioGenesisSM Sediment Washing Technology at the NYNJH site, with the ultimate goal of a commercial-scale facility capable of decontaminating 380 m³ (500,000 yd³) of dredged material per year. Based on the materials mass balance for this pilot study, 2,314 kg (5,102 lb) of untreated sediment solids resulted in 1,567 kg (3,455 lb) of treated sediment solids, with the remaining 747 kg (1,647 lb) of solids being disposed of within the centrate. The Venice pilot treated 250 m³ (330 yd³) sediment. The validation run for each of the four sediments investigated treated 18,000 to 36,000 kg (40,000 to 80,000 lb) at roughly 30% solids. The total mass of solids and liquids leaving the process was 60 to 100% more than the feed mass.

As a demonstration of a full-scale processing rate, Biogenesis used its process and all components of a commercial-scale facility to treat 31 m³ (40 yd³)/hr or 190,000 m³ (250,000 yd³)/year in treating 11,000 m³ (15,000 yd³) of sediment from three sites in NYNJ Harbor (Biogenesis Washing BGW, LLC, and MHW Americas, Inc. 2009). The demonstration was conducted in 2006 at a site in Keasbey, NJ, under contract to the NJOT Office of Maritime Resources.

BioGenesisSM residuals

Residual process streams resulting from the BioGenesisSM Sediment Treatment Process include the following:

- Debris and over-sized material removed from the pre-screening process
- Organic material skimmed from the aeration unit
- Wastewater treatment sludge, sand filter backwash, spent activated carbon
- Treated wastewater not recycled to the process stream

During the NYNJH Phase 1 pilot study, approximately 298,000 gal of wastewater was generated during the treatment of approximately 540 m³ (700 yd³) of sediment. The high-pressure water flow rate in the pre-processor unit and collision chamber during the NYNJH pilot testing was approximately 0.23 m³/minute (60 gal/minute (gpm)). The full-scale

conceptual design criteria for the Venice facility (BioGenesis Italia, LLC, et al. 2005) assumed generation of approximately 47.6 m³ of wastewater per hour (300,000 gal/day (gpd)) for a sediment process flow rate of 34 m³/hr (45 yd³/hr, or 230,000 gpd).

The aqueous centrate will likely contain fine solids, treatment chemicals, and dissolved and particulate-associated contaminants. Depending on the wastewater quality, including solids and contaminant concentrations, pretreatment will likely be required before it can be accepted by a wastewater treatment facility or discharged as a permitted discharge to a receiving water body. The current configuration of the Biogenesis process illustrated in Figure 13 included clarification, carbon absorption, and sand filtration wastewater treatment.

Beneficial use product

As discussed in the section of Chapter 2 titled “Beneficial use end product,” treated sediment resulting from the BioGenesisSM Sediment Washing Technology process could potentially be used in a number of ways. The coarse-grained material can be used as an ingredient of construction backfill, and with the addition of soil amendments, fine-grained treated sediment can be made into top soil. The application of treated sediment as a soil beneficial use product will be dependent on treatment efficiency, resulting chemical concentrations in the treated sediment, and applicable environmental criteria and regulations.

The 2006 demonstration blended treated sediment with sand (20.45 tons/yd³) and mulch (0.25 tons/yd³) to produce a manufactured topsoil passing unrestricted use regulations.¹

¹ Personal Communication. August 23, 2010. John Sontag, Jr., Vice President, Director of Engineering, Biogenesis Enterprises, Inc., West Chester, PA.

4 Cost Evaluation

Scope

General

While all of the technologies demonstrated under the validation programs were required to provide cost estimates for operation at full scale, a standardized template or format for determining estimated costs was not provided. In addition, there was some indication that the resulting unit costs were influenced by the objectives of these demonstrations, which was to show that sediment could be treated for under \$46/m³ (\$35/yd³)¹. As a result, direct comparisons of the cost estimates provided for the different technologies were difficult. Baseline assumptions differed considerably from one technology to another. The period of capital cost recovery, annual production, and assumptions regarding revenues produced from the sale of beneficial use products vary greatly. Further, cost projections typically do not include costs associated with pre-treatment, the impacts of reduced dredge production, the impacts of intermittent or short-term feed supply, and the treatment and disposal of residuals. These are not insignificant line items, and the entire treatment train, including pre- and post-treatment processes, must be considered in evaluating costs. An estimate of the "integrated" cost of the treatment process, inclusive of these factors and derived from the same baseline, is needed for each treatment technology. Therefore, in addition to reviewing requirements and efficiencies of the treatment processes, treatment costs were evaluated in this report for the purpose of:

- a. Understanding the basis of the vendor reported costs;
- b. Identifying potential costs not considered by the developers;
- c. Comparing costs and benefits of all treatment alternatives;
- d. Formulating standardized conditions and assumptions that can be used for an impartial comparative evaluation; and

¹ USEPA, USACE, and USDOE. 1999Fast Track Dredged Material Decontamination Demonstration for the Port of New York and New Jersey– Report to Congress on the Water Resources and Development Acts of 1990 (Section 412), 1992 (Section 405C), and 1996 (Section 226). EPA 000-0-99000. "The target range of costs for full-scale/commercial-scale operations is to be at or below \$35/yd³." "ONJMR's goal is to assess the feasibility of technologies that can provide long-term decontamination services for the Port at full-scale costs of no more than \$35/yd³ exclusive of dredging."

- e. Evaluating the relative sensitivity of the cost estimates to variation and uncertainty of major cost factors.

Contents of the chapter

Documents that include economic evaluations prepared by the technology developers and that were reviewed are listed below.

- BioGenesis Enterprises, Inc., and Roy F. Weston, Inc. 1999. Full Scale, 40 yd³/hour, Sediment decontamination Facility for the NY/NJ Harbor Region, Final Report on the Pilot Demonstration Project. Springfield, VA. Submitted to Brookhaven National Laboratory, Upton, NY.
- BioGenesis Italia, LLC., MHW Americas, Inc., and Jan de Nul, N.V. 2005. Pilot Scale Demonstration Project of the BioGenesisSM Sediment Decontamination Process, Autorità Portuale di Venezia, Porto Marghera, Venice, Italy. Springfield, VA.
- BioGenesis Enterprises, Inc. 2008. Final Report: BioGenesisSM Sediment Washing Technology, Bench Scale Treatability Study Report Housatonic River–Rest-of-River Site. Springfield, VA. Prepared for ARCADIS, Syracuse, NY.
- BioGenesis Washing BGW, LLC, and MHW Americas, Inc. 2009. “Demonstration Testing and Full-Scale Operation of the BioGenesisSM Sediment Decontamination Process – Final Report”, December 17, 2009, Springfield, VA.
- JCI/Ucycle Associates, LLC. 2002. “Final Summary Report, Sediment Decontamination and Beneficial Use Pilot Project”, Prepared for New Jersey Department of Transportation, Office of Maritime Resources, Project AO#9350203 and United States Environmental Protection Agency – Region 2, through Brookhaven National Laboratory, Contract Number 48172, Upton, NY.
- Rehmat, Amir, Anthony Lee, and Michael C. Mensinger. 1999. “Cement-LockTM Technology for Decontaminating Dredged Estuarine Sediments.” Final Report, Phase II: Pilot-Scale Studies, Institute of Gas Technology, Des Plaines, IL, Submitted to Brookhaven National Laboratory, Upton, NY.
- Rehmat, A., A. Lee, A. Goyal, M. C. Mensinger. 1999. Construction-grade cement production from contaminated sediments using Cement-Lock[®] Technology: In: R. E. Randall (Ed.), Proceedings of the Western Dredging Association 19th Technical Conference and 31st Texas A&M Dredging Seminar, Louisville, Kentucky, 16-18 May 1999, CDS report no. 371, pp. 555-566, Texas A&M University Center for Dredging Studies, College Station, TX.
- Mensinger, Michael C., and T. Robert Sheng. 2006. Sediment Decontamination Demonstration Program: Cement-Lock[®] Technology, Phase I Pilot Test Final Report., ENDESCO Clean Harbors, LLC. Des Plaines, IL, Submitted to NJ Department of Transportation, Office of Maritime Resources, Trenton, NJ.
- Mensinger, Michael C. 2007. Cement-Lock[®] Technology for Decontaminating Dredged Estuarine Sediments, Phase II-Demonstration-Scale Project. Project Status Report for November 2006 and March, Institute of Gas Technology, Des Plaines, IL

- Mensingher, Michael C. 2008a. Sediment decontamination Demonstration Program – Cement–Lock Technology, Final Report: Phase II Demonstration Tests with Stratus Petroleum and Passaic River Sediments. Prepared under subcontract to ENDESCO Clean Harbors by Gas Technology Institute for NJDOT, Office of Maritime resources, Trenton, NJ, and USDOE, Brookhaven Science Associates, LLC, Upton, NY.
- Minergy. 2003. Revised Unit Cost Study for Commercial-Scale Sediment Melter Facility, Glass Furnace Technology. Prepared for Wisconsin Department of Natural Resources, Madison, WI.
- USEPA. 2004. Minergy Corporation Glass Furnace Technology Evaluation -Innovative Technology Evaluation Report, EPA/540/R-03/500, National Risk Management Research Laboratory Office of Research and Development U.S. Environmental Protection Agency Cincinnati, OH.
- USEPA. 1993. BioGenesis™ Soil Washing Technology, Innovative Technology Evaluation Report. EPA/540/R-93/510. Risk Reduction Engineering Laboratory, Office Of Research And Development, U.S. Environmental Protection Agency, Cincinnati, OH.

A brief description of previous cost evaluations presented in the documents listed above is presented in the section titled, “Evaluation of costs provided by the technology developers.”

As described later in this report, each technology has reported economic evaluations that differ from one another in scope and nature. Nevertheless, most of the evaluations have been based on estimating costs by engineering methods, an approach that basically consists of consolidating estimates from various separate work segments into a total project estimate. In the section titled “Baseline cost estimates,” activities, conditions and assumptions regarding treatment, service life, and market values are discussed with the purpose of formulating standard cost line items which can be used for an impartial comparative evaluation. This report does not address regional differences in costs of the various elements.

In the section titled “Evaluation of costs provided by the technology developers,” cost evaluations for each technology are incorporated into standard line items, to illustrate the differences in the basis of each cost estimate. Data gaps are then identified and discussed. To be comparable, cost estimates for each technology need to be reformulated using a common approach, which might utilize one or more of the following: catalog prices, expert opinion, industrial engineering standards, and reported literature. In the absence of other information, cost estimates

from similar technologies may provide one benchmark for preliminary cost evaluations.

Baseline cost items

In addition to differing from one another in scope and nature, cost data for each technology were also based on different demonstration scales (production volumes) as shown in Table 27.

Table 27. Demonstration projects used by the technology developers for scaling up cost estimates to full scale.

Parameter	Rotary Kiln	Cement-Lock®	Cement-Lock®	Minergy	BioGenesis SM – 1999 (1)	BioGenesis SM – 1999 (2)	BioGenesis SM 2004	BioGenesis SM 2006
Year Completed	2000	2000-2005	2006-2007	2001	1999	1999	2003-2004	2006
Volume Dredged Material Treated (in situ yd ³)	7 m ³ (10 yd ³)	380 m ³ (500 yd ³)	34 m ³ (44 yd ³)	38 m ³ (50 yd ³)	540 m ³ (700 yd ³)	540 m ³ (700 yd ³)	250 m ³ (330 yd ³)	11,000 m ³ (15,000 yd ³)

To better understand the differences among each economic evaluation, it is prudent to develop a preliminary baseline where different activities are categorized into distinctive groups and work segments. Additionally, to provide a basis for cost comparison between these technologies, it would be necessary to fix the magnitude, frequency, and duration of dredged material to be treated and define cost items that should be included in the unit costs presented by the technology developer. Selection of appropriate cost items should also consider the business model used by the technology developer or proponent.

Capital costs

Capital costs mainly involve those associated with land acquisition, site preparation, facility buildings, equipment procurement, and equipment installation. Each of these groups generally include costs for engineering, permitting, legal, and administration.

In assessing capital costs, the economic life for each alternative and the period over which the alternatives will be compared must be known. It should be noted that the economic life of a project is the period of time over which the benefits or value to be gained from a project may reasonably be expected to accrue. The economic life is then limited by: (a) the period the

facility will be functioning effectively before it is exhausted in a physical sense, i.e., its physical life; and (b) the period before which improved technologies make the present technology obsolete, i.e., its technological life. As presented in Table 28, the economic evaluations presented by the technology developers included project life values ranging from 15 years to 30 years.

Table 28. Technology developer cost estimating basis and assumptions.

Parameter	Rotary Kiln	Cement-Lock® (I)	Cement-Lock® (II)	Minergy	Bio-Genesis SM – 1999 (I)	Bio-Genesis SM – 1999 (2)	Bio-Genesis SM 2004	Bio-Genesis SM 2006
Volume treated, in situ m ³ /yr	400,000	400,000	400,000	160,000	60,000	400,000	190,000	400,000
Volume treated, in situ yd ³ /yr	500,000	500,000	500,000	210,000	80,000	500,000	250,000	500,000
Project life, yrs	30	20	20	15			15	10
Discount annual rate, %	NA	NA	NA	3.3			NA	NA
Annual operation time, hrs	7466	7,884	7,884	8,400	2,000	6,261	6,261	7008
Rate of material processed, m ³ /hr	60	50	50	20	30	60	30	60
Rate of material processed, yd ³ /hr	80	60	60	25	40	80	40	80

For the pre-treatment and treatment plant, capital cost can be divided into the following items:

- **Land Acquisition** – This item can include either the purchase or lease of property needed to construct and operate the treatment facility. However, given the typical duration of a major sediment remediation project and the extent of the infrastructure and equipment needed for these facilities, purchase of the land should be included in this item. In addition, this item is very dependent on project location and market conditions and therefore must be included as a separate line item in any economic analysis.

- **Site Preparation** – This item includes the site design, access rights, utility connections and related activities necessary to prepare the site for construction of the pre-treatment and/or treatment facilities.
- **Plant Construction** – This item includes the cost to purchase and install buildings, equipment, and utilities. Integral to this item is plant design and permitting.
- **System Startup** – This item includes operator training and system startup and testing to demonstrate that the system operates as designed.
- **Power Generation** – One technology includes the generation of power. In addition to considering the additional revenue generated, capital costs for the power-generating equipment and necessary distribution infrastructure should be included.

Operating costs

In assessing operating costs, management and treatment activities should be specifically identified and evaluated. Labor costs, material costs, energy costs, overhead and profit are then estimated for each activity. Operating costs include those components required to actively process and treat the dredged material. The location of the treatment facility relative to the dredging location can significantly affect the overall operating cost by impacting the transport and disposal components and the efficiency of the overall operation.

The following activities are generally common to each of the selected treatment technologies (although not all activities represent a cost of treatment):

- **Dredging**
 - Site and material characterization
 - Permitting and environmental windows
 - Implementation of environmental control and monitoring systems
 - Dredging operations
 - Management and engineering
- **Transport of dredged materials to the treatment facilities**
 - Transport from dredging site to upland site
 - Off-loading at the upland site
 - Hauling of dredged materials to the pre-treatment facility if not located within the off-loading facility
- **Pre-treatment activities**

- Removal and cleaning of debris and oversize solids
- Storage of as-dredged material
- Initial particle size separation by mechanical screening
- Dewatering by belt-filter or plate and frame press (thermal technologies)
- Sampling and monitoring
- Control, management, and disposal of residuals:
 - * Debris and oversize solids
 - * Filtrate (thermal technologies)
 - * Management and engineering
 - * Wastewater (physical-chemical technologies and thermal technology off gas streams)
- Storage and/or transportation of pre-treated dredged material before treatment
- Treatment operations specific to each technology. However, treatment operating costs can be grouped as labor costs, material costs (which includes additives, reagents, admixtures, etc), fuel costs, and energy costs.

Additional operational costs may be incurred for staging and storage of dredged material if disparity exists between dredge production rates and pre-treatment or treatment rates.

In general, the economic evaluations performed by technology developers excluded dredging costs (as directed by the project sponsors). Although the cost of dredging could be assumed to be the same regardless of the treatment technology, the impact of throughput capacity on the dredging operation may differ. Significant dredge down time can be costly and unit cost of dredging also varies with size and type of dredge, which may also be impacted by plant capacity. The type of dredge (hydraulic vs. mechanical) being used affects the water content and volume of the dredged material, thereby influencing pre-treatment costs. With the exception of the rotary kiln technology, all the other technologies also excluded costs associated with transporting contaminated sediments to the treatment facilities. JCI/Upcycle's business model for the rotary kiln was based on using existing LWA facilities not proximate to the dredging locations, transportation for this technology was a key cost consideration.¹

¹ Personal Communication. March 2010. Jay Derman, Professional Engineer, Loudonville, NY.

Site characterization is another area where there may be some interdependence of treatment and the scope of the site characterization, if additional material testing is required in order to evaluate suitability for treatment, degree of material variability, etc. Additionally, transportation of dredged material to a disposal site would normally be required, thus the cost to transport the material to a treatment facility may or may not represent an added cost.

Evaluation of costs provided by the technology developers

As previously stated, the economic analyses performed for each technology did not include all capital and operation costs needed to carry out all the pre-treatment and treatment activities. Table 29 presents treatment costs estimated by the technology developers and updated to 2009 dollar values. The net costs include credit for sale of a beneficial use product or for electric power sales. This section presents an overview of previous economic analysis performed by each technology developer.

Table 29. Reported cost from technology developers.

Parameter	Rotary kiln	Cement-Lock® I	Cement-Lock® II	Minergy	BioGenesis SM I	BioGenesis SM II	BioGenesis SM III	BioGenesis SM IV
Year basis for cost estimate	2002	2005	2007	2003	1999	1999	2004	2008
Total unit costs (\$ per in situ yd ³) ¹	\$42.32	\$93.15	\$100.65	\$38.74	\$89.00	\$35.00	\$61.38	\$51.33
Total unit beneficial use value		\$58.18	\$60.61	\$0.70				\$11.16
Total cost - benefits per unit (original year-dollar basis)	\$42.32	\$34.97	\$40.05	\$38.04	\$89.00	\$35.00	\$61.38	\$40.17
Total cost - benefits per unit (Dec 2009 year-dollar basis)	\$56	\$41	\$41	\$49	\$130	\$50	\$75	\$42
Reported accuracy of cost estimate	NR	+30 to -30%	+30 to -30%	+50 to -30%	NR	NR	+50 to -30%	NR

General considerations

As summarized in the following sections, to carry out the activities listed above, each technology developer has conducted economic evaluations that differ from one another in scope and nature. The revenues that could be expected from the sale of beneficial use product are somewhat speculative at

¹ To convert \$/yd³ to \$/m³, multiply by 1.31.

this point and will require locale-specific verification and market acceptance. Generally, these values are based on market value of competing materials that are not associated with the presence of contaminants, and they assume that the market needs more of these products at the current price. A performance history will have to be established before the full value of the beneficial use products can be realized.

Rotary kiln technology - reported costs

The economic analysis provided for this technology was based on the results obtained during the 2000 Pilot Project as reported in JCI/Upcycle Associates, LLC (2002). The dewatering phase was performed at Stratus Petroleum facility in Newark, NJ. The rotary kiln processing phase was conducted at the R&D Facility of FFE Minerals in Catasauqua, PA.

Although actual costs for the pilot project were not provided, treatment costs for a full-scale operation were estimated (by the developer) making the following general key assumptions:

- A minimum annual volume of contaminated dredged material of 380,000 in situ m³ (500,000 yd³)
- A project life of 30 years
- A 24-hr day, 7 days per week schedule for treatment operations, 5 days per week for pretreatment operations

The following assumptions are specific to this technology and to the commercial model JCI/Upcycle proposed to the NJDOT and the USEPA.

- Capital costs are estimated for the dewatering facility, which is assumed to be located within the Port region. The facility is assumed to be a 40,000-m² (10-acre) site with a 2,300-m² (25,000-ft²) building for administrative, laboratory, and processing operations. In addition to its dewatering operation areas, the facility includes storage areas for unprocessed as-dredged material and dewatered filter cake.
- Fixed equipment is amortized over an operating life of 10 years.
- It is assumed that the dewatered filter cake is transported via rail to an existing LWA production plant.
- Operating costs for the kiln process and production of the LWA as reported by FEE Minerals are not included because the LWA facility owner is responsible for all direct kiln processing costs. A unit operating cost for the kiln processing was estimated by JCI/Upcycle as

- approximately \$4.32/m³ (\$3.30/yd³) of in situ dredged material to cover intermediate storage, handling, drying, grinding, extruding, etc.
- Similarly, capital investment and expenses for construction of the LWA facility are not included. It is stated that the operating and capital costs for the LWA facility would be offset by the earned revenue from the LWA sales, which would be accrued by the facility owner, and by savings in transportation and material handling costs.

By following the above assumptions, a unit price (2002\$) of \$55.35/m³ (\$42.32/yd³) in situ was estimated. Again, this unit cost does not include construction of the rotary kiln facility. The business model assumed that the material would be transported to an existing Light Weight Aggregate (LWA) manufacturing facility for processing.

Referring to the 2001 FFE Minerals report in JCI/Upcycle Associates, LLC (2002), the estimated production costs (2002\$) for LWA are \$24.96/m³ (\$19.08/yd³), which factors in additional fuel costs that would be incurred as a result of adding an after-burner to the process to process dredged material. FFE also provided an estimated cost for construction of a new rotary kiln/LWA facility as \$30MM.

Cement-Lock® technology - reported costs

The initial economic analysis provided for the Cement-Lock® Technology was based on Phase II Pilot-scale Studies (Rehmat, et al. 1999a, 1999b) and was very limited. Based on processing 2.3 m³ (3 yd³) of material, the processing costs were estimated to be \$55/mton (\$50/ton). It was further estimated that the construction grade cement product was valued at \$55 to \$77 per mton (\$50 to \$70 per ton) in the market, indicating that the market value of the beneficial end product can offset the processing cost.

The final report for the Phase I Pilot Test (Mensingher and Sheng 2006) was also reviewed. During this pilot test, 380 m³ (500 yd³) of material was processed. This report contains a detailed economic analysis, predicated by the expectation that the cost per unit volume should not exceed \$46/m³ (\$35/yd³), which is the assumed tipping fee to dispose of dredged material. The economic analysis considers a full-scale commercial operation including the expected revenue from sale of Ecomelt® and electric power generation.

Treatment costs reported in Mensinger (2008a) for a full-scale commercial operation were based on the following main assumptions:

- A minimum annual volume of 380,000 m³ (500,000 yd³) in situ of contaminated dredged material
- A project life of 20 years
- A 24-hr day, 7 day per week schedule for treatment operations
- On-line stream factor 90% of the time
- Estimated revenue from Ecomelt[®] product and electric power generation

The following assumptions are specific to this technology and to the economic analysis developed for the full-scale commercial model proposed by the Gas Technology Institute:

- Land required for plant is estimated to be 101,000 m² (25 acres).
- The plant design consists of multiple treatment trains to achieve the needed capacity and no spare equipment.
- Dredged material is off-loaded from barges, screened to remove large debris, and stored in a 32,000-m² (8-acre) onsite sediment storage area.
- The sediment is transferred to sediment dryers by crane unloaders.
- Dredged sediment is dried in indirect-contact, rotary steam-tube dryers.
- Dried sediment is transferred to the Ecomelt[®] generators, where feed materials are melted.
- Off-gases from the Ecomelt[®] generator are subjected to secondary combustion and off-gases from the process are cooled in heat recovery boilers.
- A portion of the steam from the boilers is directed to the sediment dryers and the remainder is fed to steam turbine generators to generate electric power.
- The electric power is used to supply power to the plant and the remainder is exported to the grid.
- Electric power can be sold back to the grid at a rate of \$100/MWhr.
- The Ecomelt[®] product can be sold at a rate (\$2007) of \$94/mton (\$85/ton).

Based on this model, the “break-even” tipping fee, or the unit rate that must be charged for processing the material to cover costs not offset by

revenue (2007\$), was estimated to be \$52.32/m³ (\$40.05/yd³). Excluding the estimated revenue streams, the processing cost (2007\$) was estimated to be \$132/m³ (\$101/yd³).

Minergy glass furnace technology - reported costs

The available economic analysis for Minergy Glass Furnace Technology (GFT) is provided in Minergy (2003a) and in USEPA (2004) and is based on a full-scale system designed for a river sediment dredging project. That system would be designed to process 540 mton (600 tons) per day of dewatered sediment, operating 24 hr/day, 350 days/year. Under this operating scenario, 190,000 mton (210,000 tons) of 50% dewatered sediment would be processed in a year and the estimated unit cost in \$2003 is approximately \$43/mton (\$39/ton) using a net present value analysis (USEPA 2004). This estimated unit cost includes most key components, except for sediment dewatering, residuals disposal, and revenue generated from sale of the glass product.

The vendor also assessed cost sensitivity based on different operating rates, ranging from 450 mtons (500 tons)/day to 2,000 mtons (2,250 tons)/day of dewatered dredged material, demonstrating that the unit cost could be reduced to \$32/mton (\$29/ton) with increased processing rates and allowing \$2.2/mton (\$2/ton) revenue from the glass aggregate product.

Treatment costs for a full-scale operation were based on the following main assumptions:

- An annual volume of 190,000 mtons (210,000 tons) dewatered sediment (200,000 m³ (260,000 yd³) in situ) of contaminated dredged material
- A project life of 15 years
- A 24-hr day, 350 day/year schedule for treatment operations

BioGenesisSM sediment washing - reported costs

1999 demonstration project costs (BioGenesisSM I)

In 1999, BioGenesisSM was evaluated as a sediment washing technology that could be used for treating dredged material. The pilot demonstration project was set up at the Stratus Petroleum Corporation – Newark Terminal Site located in Newark, NJ. Based on a 31-m³ (40-yd³)/hr facility

and 61,000 m³ (80,000 yd³) total processed, the unit cost was \$116/m³ (\$89/yd³).

Projected costs based on 1999 project (BioGenesisSM II)

BioGenesis Enterprises, Inc., and Roy F. Weston, Inc. (1999) projected that they could lower the cost of \$116/m³ (\$89/yd³) to \$38-46/m³ (\$29-35/yd³) by doubling the capacity of the facility to 60 m³/hour (80 yd³/hr) for a total of 380,000 m³/year (500,000 yd³/year). This estimate assumed operating costs, such as utilities, maintenance and waste disposal, but did not appear to account for the cost to construct the processing facility. The unit cost for the full-scale operation was also discounted by unspecified revenue that would be generated from the beneficial use sale of the product, recognizing that the market value of that material could vary.

Treatment costs for a full-scale operation were based on the following main assumptions:

- A minimum annual in situ volume of 380,000 m³ (500,000 yd³) of contaminated dredged material
- The project life was not specified in BioGenesis Enterprises, Inc., and Roy F. Weston, Inc. (1999)
- A 24-hr day, 350 days/year schedule for treatment operations

The following list includes the main cost items included in Biogenesis' economic analysis:

- Analytical costs
- Operating expenses
 - Field offices
 - Utilities
 - Maintenance
 - Waste disposal
 - Beneficial use sale
- Equipment rentals/lease
- Labor and expenses
 - Union labor
 - Management labor
- Chemical costs

Venice project costs (BioGenesisSM III)

In 2003/2004 BioGenesis performed a Pilot Demonstration Project in Venice, Italy (BioGenesis Italia, LLC, et al. 2005). A volume of 250 m³ (330 yd³) of material was processed. Based on the results of this project, and on a conceptual system design, BioGenesis estimated the unit cost for a full-scale operation to be \$80.28/m³ (\$61.38/yd³). The estimated unit cost was not discounted by the sale of beneficial use product.

Treatment costs for a full-scale operation were based on the following main assumptions:

- Project volume of 190,000 m³/year (250,000 yd³/year)
- A project life of 15 years
- A 24-hr day, 365 days/year schedule for treatment operations

Cost based on Keasby, NJ full-scale demonstration (BioGenesisSM IV)

Biogenesis's demonstration at Keasby, NJ, used full-scale (31 m³/hr (40 yd³/hr)) process equipment to treat sediment from three NYNJH sites. Commercial scale treatment costs were estimated for 31 and 61 m³/hr (40 and 80 yd³/hr) (190,000 and 380,000 m³/year (250,000 and 500,000 yd³/year)) to be \$76.93/m³ and \$67.14/m³ (58.82/yd³ and \$51.33/yd³), respectively (BiogenesisSM Washing BGW, LLC, and MWH Americas, Inc. 2009). These costs were based on the following main assumptions:

- Addition of a micro-floatation unit to the process configuration used for the demonstration project
- 35 acres of land for a 380,000 m³/year (500,000 yd³/year) facility
- Operations 365 days/year, 24 hr/day with 80% uptime
- \$11.30 net value assigned for use of treated sediment in manufactured soil
- Offloading sediment and pre-treatment integral to the process

The following list includes the main cost items included in Biogenesis' economic analysis.

- Equipment capital cost, including purchase, installation, mechanical, electrical, and instrumentation
- Site preparation and process building construction

- Contingency (15% of capital costs)
- Overhead costs
- Operating costs (labor, power, water, wastewater disposal, solids waste disposal, chemicals, maintenance)
- Straight-line depreciation of capital costs
- Sale of manufactured top soil

Data gaps and adjusted costs

Standard line items for capital and operating costs included in the technology developer's estimates are listed in Tables 30 and 31. Only the most recent cost estimates reported by the developer are included. All costs are presented on a per cubic yard in situ sediment basis. For each line item, the tables present values where the technology developer considered the item in the developer's cost estimate. Cost items that were not specifically evaluated but that are part of a combination of activities are indicated as included (Inc). The activities that were not included in the cost evaluation provided by the technology developer are indicated with an **X**. "Non Needed" (NN) cost line items correspond to those that were not needed to be evaluated under the assumptions made by the technology developer. In instances where the inclusion of an activity cost is not clear, those line items are identified in the table with a question mark (?).

In an effort to make the costs for the four developers more comparable, missing costs were estimated based on available data and costs for the same item from other developers. In particular, Minergy's cost estimate did not include dewatering costs; therefore, costs for debris removal and disposal and for sediment handling and dewatering were estimated for the Minergy process. Those values estimated for this report are indicated by shading of the cell.

As stated earlier, the rotary kiln cost estimate only included costs for pretreatment (handling, dewatering, etc.), not for the rotary kiln treatment. The business model for the rotary kiln alternative assumed that an existing rotary kiln could produce the LWA product at a value equal to or exceeding the cost for rotary kiln treatment. JCI/Upcycle Associates, LLC, (2002) reported a value for LWA, which was extrapolated to an in situ sediment volume, as well as an income for sale of the LWA.

Table 30. Capital cost estimate comparisons (cost line items \$/yd³).¹

Cost Item No.		Rotary Kiln LWA	Cement-Lock®	Minergy GFT	Bio-Genesis SM - IV
	Volume basis, m ³	380,000	380,000	380,000	430,000
	Volume basis for cost data, yd ³	500,000	500,000	500,000	560,640
	Cost year basis	2009	2009	2009	2009
	Years straight line depreciation	10	20	15	10
CC-1	Pre-treatment facility				
CC-1.1	Land acquisition (purchase or lease)	Inc	Inc	\$0.20	Inc
CC-1.2	Site preparation, planning, design and permitting	Inc	\$0.31	Inc	Inc
CC-1.3	Plant construction				
CC-1.3.1	Building (materials, construction, engineering, etc)	\$3.97	\$0.36	\$0.72	Inc
CC-1.3.2	Equipment (purchase)	Inc	\$0.32	\$0.87	Inc
CC-1.3.3	Equipment (installation, engineering, etc)	Inc	Inc	\$0.32	Inc
CC-1.3.4	Utilities (materials, installation and connection)	Inc	Inc	Inc	Inc
CC-1.4	Other capital costs	?	?	?	?
CC-2	Treatment facility				
CC-2.1	Land acquisition (purchase or lease)	NN	Inc	X	Inc
CC-2.2	Site preparation, planning, design and permitting	NN	Inc	Inc	\$0.17
CC-2.3	Plant construction				
CC-2.3.1	Building (materials, construction, engineering, etc)	NN	Inc	Inc	\$0.45
CC-2.3.2	Equipment (purchase)	NN	\$1.89	\$4.55	\$1.93
CC-2.3.3	Equipment (installation, engineering, etc)	NN	\$2.11	\$5.79	\$1.06
CC-2.3.4	Utilities (materials, installation and connection)	NN	\$1.85	Inc	\$0.02
CC-2.4	Other capital costs (if reported)	NN	?	?	?
CC-3	Other				
CC-3.1	Power generation	NN	\$0.51	NN	NN
CC-3.2	System startup	Inc	X	\$0.23	X
CC-3.3	Capital cost contingency	?	\$0.81	\$1.55	\$0.54
Notes					
Inc	Included in developer's cost				
X	Not included in developer's cost				
NN	Not Needed for this technology				
?	Unclear if item included in cost estimate reported for this technology				
\$0.00	Cost item estimate added by this analysis to make cost estimates more complete and facilitate comparison				

¹ To convert \$/yd³ to \$/m³, multiply by 1.31.

Table 31. Operating cost estimate comparisons (Continued)

Cost Item No.		Rotary Kiln LWA 2009\$	Cement- Lock® 2009\$	Minergy GFT 2009\$	Bio-Genesis SM - IV 2009\$
OC-1	Dredging of contaminated sediments				
OC-1.1	Site and material characterization	X	X	X	X
OC-1.2	Permitting	X	X	X	X
OC-1.3	Environmental control and monitoring systems	X	X	X	X
OC-1.4	Dredging operations	X	X	X	X
OC-1.5	Management and engineering	X	X	X	X
OC-1.6	Overhead & profit	X	X	X	X
OC-2	Transport to pre-treatment facilities and off-loading				
OC-2.1	Transport from dredging site to off-loading site	NN	Inc	Inc	NN
OC-2.2	Off-loading at the upland site	\$2.32	Inc	\$3.61	Inc
OC-2.3	Transportation to pre-treatment facility	Inc	Inc	Inc	NN
OC-2.4	Overhead & profit	Inc	Inc	?	\$ -
OC-3	Pre-treatment				
OC-3.1	Removal of large solids and debris	Inc	Inc	\$0.71	Inc
OC-3.2	Storage and handling of as-dredged material	\$3.97	\$0.51	\$2.67	Inc
OC-3.3	Mechanical screening	Inc	NN	\$0.81	Inc
OC-3.4	Dewatering	\$9.60	NN	\$2.03	NN
OC-3.5	Sampling and monitoring	\$0.66	X	?	X
OC-3.6	Control, management and disposal of residuals				
OC-3.6.1	Large solids and debris	\$0.99	X	\$9.95	Inc
OC-3.6.2	Screened solids	NN	X	Inc	Inc
OC-3.6.3	Effluents	\$1.99	X	\$2.32	Inc
OC-3.7	Equipment maintenance	Inc	Inc	Inc	Inc
OC-3.8	Management and engineering	Inc	Inc	Inc	Inc
OC-3.9	Overhead and profit	Inc	Inc	?	Inc
OC-4	Storage and/or transport of pre-treated dredge				
OC-4.1	Storage and handling before treatment	\$1.32	Inc	Inc	Inc
OC-4.2	Transport to treatment facility	\$14.90	NN	NN	NN
OC-4.3	Overhead and profit	Inc	Inc	?	Inc
Notes					
Inc	Included in developer's cost				
X	Not included in developer's cost				
NN	Not Needed for this technology				
?	Unclear if item included in cost estimate reported for this technology				
\$0.00	Cost item estimate added by this analysis to make cost estimates more complete and facilitate comparison				

Table 31. (Concluded)

Cost Item No.		Rotary Kiln LWA 2009\$	Cement Lock 2009\$	Minergy GFT 2009\$	Bio-Genesis SM - IV 2009\$
OC-5	Treatment				
OC-5.1	Material storage	Inc	Inc	Inc	Inc
OC-5.2	Material handling	\$4.37	Inc	Inc	Inc
OC-5.3	Treatment cost (unit cost)	\$35.76	NN	NN	Inc
OC-5.4	Treatment itemized expenses				
OC-5.4.1	Labor	Inc	\$5.52	\$8.42	\$ 9.98
OC-5.4.2	Raw materials	Inc	\$14.19	\$11.25	\$ 14.18
OC-5.4.3	Utilities-Fuel	Inc	\$48.52	\$6.01	NN
OC-5.4.4	Utilities-Electricity	Inc	\$4.32	\$4.13	\$ 6.08
OC-5.4.5	Utilities-Water	Inc	\$1.06	X	\$ 0.85
OC-5.5	Sampling and monitoring	\$0.66	X	X	X
OC-5.6	Control, management and disposal of residuals				
OC-5.6.1	Spent materials	Inc	\$0.27	X	\$ 0.16
OC-5.6.2	Solids	Inc	Inc	X	\$ 5.41
OC-5.6.3	Effluents	Inc	X	X	\$ 0.96
OC-5.7	Equipment maintenance	Inc	\$2.68	X	\$ 3.85
OC-5.8	Management and engineering	\$2.65	Inc	\$2.36	Inc
OC-5.9	Overhead & profit	\$7.31	\$12.69	?	\$ 1.04
OC-6	Other operating costs				
OC-6.1	Host fee for town/city	\$1.32	NN	NN	NN
OC-6.2	Demobilization costs	X	X	X	X
OC-6.3	Site Lease	?	\$3.26	\$3.26	\$ 5.31
	Beneficial use (BU)				
BU-1	Additional treatment	Inc	Inc	Inc	X
BU-2	Additional testing	Inc	?	X	X
BU-3.1	Revenue: sale of BU product ¹	\$35.76	\$41.81	\$0.91	\$11.30
BU-3.2	Revenue: sale of energy	NN	\$19.56	NN	NN
Total Cost		\$91.82	\$101.16	\$71.75	\$ 51.99
Net Cost		\$56.06	\$39.79	\$70.84	\$ 40.69
Notes					
Inc	Included in developer's cost				
X	Not included in developer's cost				
NN	Not Needed for this technology				
?	Unclear if item included in cost estimate reported for this technology				
\$0.00	Cost item estimate added by this analysis to make cost estimates more complete and facilitate comparison				

¹ Values for sale of BU products were updated from the value reported in the literature to 2009 using ENR CCI.

Another difference among the developers was the method for addressing depreciating capital costs and financing the project. Minergy was the only developer that used a net present value (NPV) method for annualizing the cost of the project. Although the NPV method is commonly used for these types of estimates, the Minergy cost estimate was adjusted to be the same procedure as for the other developers. The annual cost is based on reported annual operating expenses plus a straight line depreciation of capital costs based on the years reported in each developer's estimate.

Summary

In general, the economic analyses performed for each technology by the technology developers did not include all capital and operation costs needed to carry out all the pre-treatment and treatment activities, including residuals management. None of the analyses included the cost to dredge the sediment or, with exception of the rotary kiln, transport the dredged material to the processing facility. This is not unreasonable, given that these costs can vary by location, volume of material dredged, mode of transportation and distance traveled. Nonetheless, these costs can be significant and should be considered at full scale.

The bottom line adjusted total and net unit costs (as offset by the projected value of a product) in December 2009 dollars (as adjusted by ENR CCI) is presented at the bottom of Table 31. Costs were normalized for a full-scale operation based on an annual volume of 380,000 m³ (500,000 yd³) and continuous operation of the processing plant. The effect of a reduction in the amount of dredged material or possible interruption of the transport of dredged material to the processing facility was not necessarily factored into the unit cost. Interruptions of dredging due to seasonal restrictions, project funding, weather, contractual issues, and other circumstances will likely occur. Adequate storage for material awaiting treatment should be considered to avoid increasing unit costs due to decreased volumes or non-continuous operation.

Cost sensitivity

Results of a qualitative cost sensitivity analysis are summarized in Table 32. The ratings Low, Medium, and High represent a subjective assessment of change in the overall treatment cost relative to change in the listed cost factors.

Table 32. Qualitative cost sensitivity analysis.

Technology	Plant capacity	Energy costs	Residuals treatment cost	Labor costs	Capital costs	Operating costs	Beneficial use product
Rotary Kiln	Moderate	Moderate	Low	Low	Moderate	Moderate	Moderate
Cement-Lock®	Moderate	High	Low	Low	High	Moderate	Moderate
Minergy	Moderate	Moderate	Low	Low	Moderate	Moderate	High
Biogenesis SM	High	Low	High	High	Moderate	High	High

Use of the normalized cost estimates

As part of this effort, an attempt was made to establish a comparable basis for estimating unit costs for each technology, taking into account all relevant cost items for an integrated treatment train. Given the lack of full-scale performance data, these estimates provide a frame of reference for cost of treatment based on the best information available at the time, and are subject to some uncertainty (typically 30 to 50% under actual cost and as much as 30% over actual for preliminary design). These estimates are intended to inform potential technology users of the limitations of the cost estimates included as part of the vendor and government technology reports, and provide a tool potentially useful for initial technology screening efforts.

5 Commercialization Potential

From the perspective of sediment volume treated, the demonstrations described in this document have been limited to pilot scale, although some of the equipment may have been of sufficient scale to serve as part of a full-scale plant. There have been no subsequent sustained, full-scale sediment treatment operations. The technology developers for two of the technologies evaluated here—BiogenesisSM and Cement-Lock[®]—have continued to refine their processes and seek commercial scale projects, however. The following is a synopsis of the commercial status of the four technologies as of this writing.

JCI/Upcycle Rotary Kiln

There has been no further sediment treatment activity by JCI/Upcycle since the 2000 pilot demonstration.¹ Although there reportedly is still a group with interest in the use of the technology to process sediment, several issues that were an impediment are still unresolved. Chief among these is that, for this technology, a significant up-front capital investment is required, which in turn necessitates assurance of an adequate and continuous supply of raw material for processing.

The premise of the technology was to use existing kiln operations. Although there are still some kilns operating in the New York area, it is not known whether there is still interest in processing sediment. The regulatory aspects related to permitting are expected to be significantly more difficult with respect to siting a new kiln, as compared to an existing one. Staging areas would need to be permitted. Management of wastewater could be relatively straightforward for a plant located such that return flow to a receiving water body is possible. For a plant located several miles inland, however, wastewater management could be a significantly more difficult and costly issue.

One of the technical issues identified at the time of the 2000 demonstration was related to dewatering, for which at least a semi-continuous operation is required. In this area there has been further maturation of the technology, as evidenced by the full-scale separation and dewatering plants presently

¹ Personal Communication. January 13, 2010. Jay Derman, Professional Engineer, Loundonville, NY.

operating on the Fox River and at New Bedford Harbor. Technically, dewatering at a sufficient scale should be possible. A more likely limitation is the relative cost to set up and operate a dewatering operation of sufficient capacity to meet the feed requirements of an economically sustainable kiln operation. Last is the requirement of a market for the product, which is a requirement for all of the technologies. Reportedly, imports of pumice continue into this marketplace to meet the demand that manufactured LWA (whether from shale or dredged materials) is unable to fill, indicating an ongoing requirement for LWA in the northeast.¹ The potential scope of this market was not assessed as part of this effort, however.

Cement-Lock®

The controlling interest in Cement-Lock® was purchased in 2007 from the Gas Technology Institute by a private concern, Volcano Partners, which has reportedly re-designed and re-engineered the concept to bring it up to commercial readiness.² Updated contact information was provided as part of the technology brief in Chapter 2. Business models currently under consideration incorporate treatment of other waste streams in addition to contaminated dredged material.³

Minergy

At the time of the inception of this report, Minergy was not being actively marketed as a sediment treatment, although reportedly the technology had been licensed in the UK and Germany for soil/sediment treatment.⁴ Originally a subsidiary of Wisconsin Energy, the technology was sold in mid-2009 to a private concern,⁵ which is presently in the process of starting up the business. The company, which will again be known as Minergy Corp., is not presently pursuing projects in sediment remediation because of the greater opportunities for sewage sludge treatment in

¹ Personal Communication. March 2010. Jay Derman, Professional Engineer, Loudonville, NY.

² Personal Communication. January 13, 2010. Al Hendricks, Managing Member, Volcano Partners, LLC, Maitland, FL.

³ Personal Communication. February 28, 2010. Al Hendricks, Managing Member, Volcano Partners, LLC, Maitland, FL.

⁴ Personal Communication. November 4, 2007. Bob Paulson, SR. Environmental Consultant, Wisconsin Energy Corporation, Milwaukee, WI.

⁵ Personal Communication. January 12, 2010. Bob Paulson, SR. Environmental Consultant, Wisconsin Energy Corporation, Milwaukee, WI.

Europe, but may have a future interest in this area.¹ Updated contact information was provided as part of the technology brief in Chapter 2.

BiogenesisSM

Biogenesis develops and manufactures cleaning solutions for a number of different industries. The history of the company in the environmental arena dates back to 1989. A number of projects are listed on the Biogenesis internet site ranging from treatability studies on wood treating waste in sediments (Thunder Bay, Canada) to treatment of 3,400 mtons (3,800 tons) of crude oil contaminated soil (Koch Refining Co, Minneapolis, MN). The site references the New York/New Jersey harbor demonstration as most representative of their capabilities in sediment washing. Biogenesis lists an Asian partner on their website KleanEnvi Asia Co., Ltd., Yuseong-ku, DaeJeon, Republic of Korea (<http://www.biogenesis.com/kleanenvi.html>)

Obstacles to commercialization

Setting aside effectiveness considerations, there are multiple obstacles to commercialization of these technologies in the United States:

- Lack of full-scale performance history
- Availability of effective and economical disposal alternatives
- Mutually exclusive requirements for process scale and mobility
- Public acceptance
- Treatment cost uncertainty
- Business-related issues
- Undemonstrated product market and long-term performance

None of the technologies studied here are inexpensive. Each would require a significant investment to deploy at full scale in a real-world application. The absence of full-scale performance data for these technologies coupled with expected cost makes them unlikely to survive alternatives selection driven by a least-cost alternative mandate, as is the case with federal navigation projects. To become commercially viable, the technologies under consideration need to prove themselves both more effective and less expensive than existing treatment and disposal options, such as conventional soil washing, stabilization, and disposal.

¹ Personal Communication. January 12, 2010. Craig Cameron, Managing Member, Volcano Partners, LLC, Maitland, FL.

At present, disposal without treatment in confined disposal facilities (CDFs) is typically an appropriate and lower cost alternative for navigation dredging projects, which might otherwise be seen as a major application for these technologies. Over time, as in-water placement becomes more constrained, and upland placement sites near the end of their useful life, there may be sufficient economic impetus to support treatment in the management of navigation sediments, and possibly in the recovery of material from existing CDFs. Presently, treatment appears to be most applicable to those sites where active environmental remediation is taking place and treatment offers a viable alternative to costly offsite disposal. Where significant up-front capital investment for a permanent facility is required, however, material supply cannot be episodic. This requires consistent funding streams for dredging occurring within reasonable proximity to the plant, the capability of processing a variety of readily available wastes, or a modular technology that can “follow the funding stream.” To date, this issue has not been resolved. Recovery of material from existing CDFs may be a more immediate opportunity that would address some of the issues of continuity of feed, but which would still require either mobile treatment plants or transport of the material to a regionally located facility. Material recovery from CDFs may also be challenged by uncertain funding.

The lack of long-term environmental and performance data is anticipated to be an impediment to market acceptance of the treatment products, at least initially. One strategy that might be used is to incorporate use of the products as part of an overall site remediation plan. Sites at which a combination of remedies will be employed, including removal and capping, would provide the best opportunity. Decontaminated sediment produced from more contaminated sediments could be incorporated as part of the capping material for the less contaminated portions of the site; however, achieving aquatic re-use standards can be very difficult. Long-term monitoring is normally a part of the remedy specified for such sites, and this would provide the opportunity to obtain performance data for these products in a beneficial use application. Some analytical cost savings could be realized in this manner, raw materials required for capping reduced, off-site disposal costs eliminated, and market value of the product removed from the equation. This approach could ultimately provide a stepping stone to a niche for these technologies.

6 Comparative Process Summary

Ultimately, reconstructing the mass balances and interpreting the results proved to be a more difficult task than initially anticipated, in part because of the need to first consolidate the information from multiple demonstrations and reports, and in part due to limitations of the available data and the manner in which the data were presented. The mass balance analysis that was undertaken “after the fact” here was very labor-intensive, and such an in-depth analysis would not likely be feasible for technology consumers. However, the analysis demonstrates the importance of a complete mass balance approach to understanding the operative removal mechanisms, accounting for contaminant and material fate, estimating the magnitude of residuals and cost to manage them, and overall environmental impact of a technology.

It was apparent from the analysis done here that a variety of loss and treatment mechanisms are involved to varying degrees with all of these technologies. The data provided showed that thermal and chemical destruction, volatilization, immobilization, particle separation, solubilization, dilution and even incidental losses played a role in contaminant reduction.

All four of the technologies evaluated, three thermal and one physical/chemical process, were shown to achieve contaminant reduction, though the mechanisms of treatment and the overall efficiency of the processes differed. The thermal technologies are effective at achieving destruction of organic contaminants and immobilization of metals, although some metals remained leachable (as measured by the TCLP, SLP, or the MEP) at low concentrations. Mercury removal was largely attributed to volatilization for all technologies. Metals mass measured in the aggregate produced by Rotary Kiln and Cement-Lock[®] ranged from approximately 30 to 60% of total incoming metals mass (Table 33), though generally only a small proportion of this mass was leachable. The fraction of metals leachable in the Rotary Kiln aggregate ranged from zero to over 100% in one case, with the median for both TCLP and MEP between 2.91 and 3.25%. The fraction of metals leachable in the Cement-Lock[®] aggregate (TCLP mass/total metals in aggregate) ranged from zero to 20% with average and median values of 3.0 and 0.28%, respectively. The fraction of metals

Table 33. Thermal technologies - material and contaminant mass as percent of incoming material and contaminant mass in filter cake feed.

Process	Non-sediment material input (shale/modifiers/quench water)	Outgoing product or waste streams				
		Product	Off-gases	Particulates	Waste-water	Destroyed or Unaccounted for
Solids						
Rotary Kiln	38	110	0.11	15 ^b	13	0.00
Minergy	5.54	81.5	0.00	17.0	8.50	0.00
Cement-Lock®	39	114	24	NR	NR	0.00
Water						
Rotary Kiln	0.15	0.00	200 ^b	0.00	11	0.00
Minergy	0.139	0.00	90 ^b	0.00	10	0.00
Cement-Lock®	102 ^d	0.00	202	NR	NR	0.0
Metals						
Rotary Kiln	22	30	0.028	15	0.063	55
Minergy	0.00	186.0	0.00	0.00	0.409	0.00
Cement-Lock®	NR	46	0.12	NR	NR	54
SVOCs/PAHs						
Rotary Kiln	0.00	0.00	2.4	15	0.0	83
Minergy	0.00	0.00	0.00	29.5	119.0	0.00
Cement-Lock®	NR	0.0022	0.037	NR	NR	99.9
Dioxins						
Rotary Kiln	0.00	0.52	0.49	15	0.00	84
Minergy	0.00220	0.0151	0.00	0.00350	0.0739	99.9
Cement-Lock®	NR	0.091 ^c	0.0028	NR	NR	99.6
PCBs						
Rotary Kiln	0.00	0.00	1.2	15	0	84
Minergy	0.000179	0.00138	0.00	0.0000559	1.57	98.4
Cement-Lock®	NR	0.0087	0.022	NR	NR	99.9
Pesticides						
Rotary Kiln	0.00	0.00	0.00	15	0.00	85
Minergy						
Cement-Lock®	NR	0.00	0.00	0.00	0.00	100.0
<p>a) Rotary kiln particulate losses consist primarily of assumed dryer losses (14.7% of feed mass)</p> <p>b) Includes water in dryer offgases which could either be released to the atmosphere or condensed and managed as a wastewater stream depending upon the system configuration</p> <p>c) One of 8 samples analyzed for dioxins/furans appeared to be an outlier and was deleted in arriving at this average.</p> <p>d) Makeup water for granulator</p>						

leachable in the Cement-Lock[®] aggregate (TCLP mass/total metals in raw feed) ranged from zero to 8.8%, with average and median values of 1.1 and 0.24%, respectively. Total metals mass measurable in the aggregate for Minergy ranged from 0 to 368% of metals mass coming into the kiln; reflecting a large unexplained increase in barium mass.

SVOCs/PAHs were below detection in the aggregate for all three thermal technologies. As much as 2.4% of incoming SVOC mass was measured in the off-gases produced by the thermal technologies, and up to 30% in the off-gas particulates (Table 33). For Minergy, SVOCs in the wastewater exceeded 100% of incoming SVOC mass. For Cement-Lock[®], 99.9% of the incoming PAHs were unaccounted for in output process streams and presumably destroyed. Similarly, between 85 and 100% of incoming pesticides mass was unaccounted for in the Rotary Kiln and Cement-Lock[®] processes (Table 33). Approximately 0.091% of incoming total dioxin/furan mass was measurable in the Cement-Lock[®] product (Table 33 and Cement-Lock[®] Mass Balance Appendix C), with a maximum of 8.6% for an individual congener (1,2,3,7,8,9-HxCDF). For the remaining two thermal technologies, this mass in the aggregate was less than 1%, and overall between 84.5 to 99.9% of dioxin mass was unaccounted for and presumed destroyed.

Measurable PCBs were found in all output streams (Table 33). The PCBs mass found in the off-gas stream for Cement-Lock[®] was 0.0087% of incoming sediment PCBs mass, with 99.9% (not including the 30% of input mass adsorbed by the carbon bed) unaccounted for and presumed destroyed. For Minergy, 98.4% of incoming PCBs mass was unaccounted for and presumed destroyed.

All three thermal technologies require the addition of some type of modifier, increasing the total mass of solids going through the system from approximately 6 to 39% (Figure 44). This increase in mass effectively results in varying levels of dilution of contaminants present in the feed. A portion of the treatment efficiency for the thermal technologies is therefore attributable to this contaminant reduction mechanism. This is mostly of relevance for metals since the organics are largely destroyed in the process. Particulates lost to the off-gas stream ranged from 15 to 17% of the incoming solids mass for Rotary Kiln and Minergy, but was not reported for Cement-Lock[®]. A measurable percentage of particulate-associated contaminants were lost to the offgas stream, as indicated in

Table 33. However, these solids could conceivably be recycled through the system to avoid generating a solid waste stream.

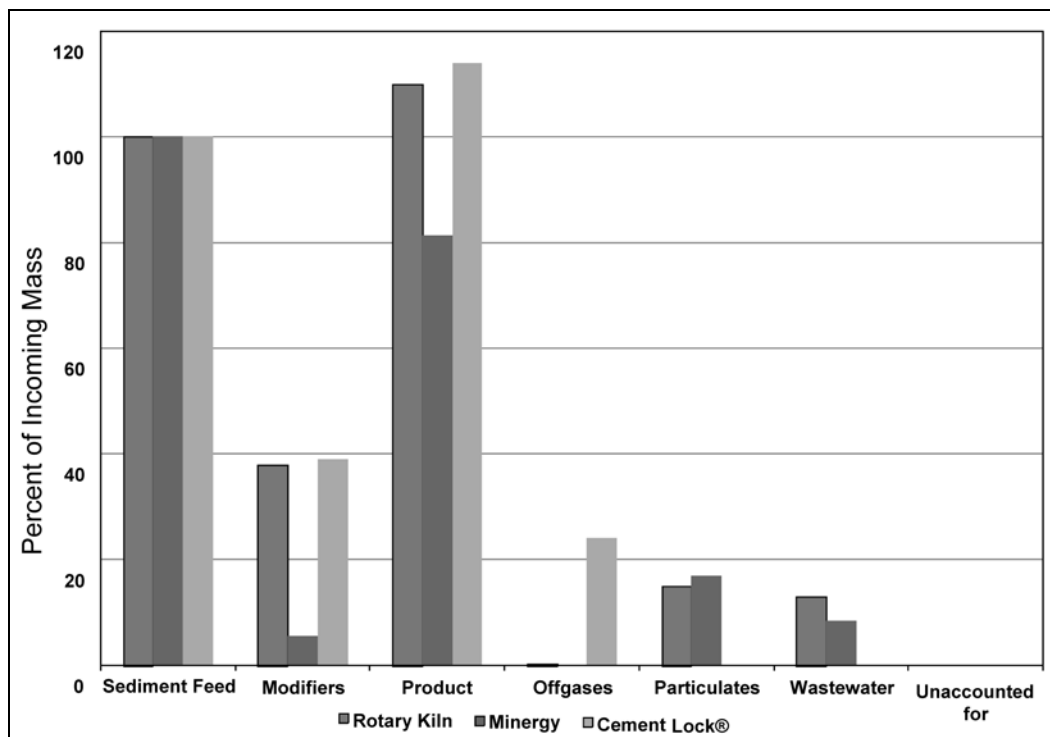

Figure 44. Solids mass balance – thermal technologies.

While the BioGenesisSM Sediment Washing technology also achieved some measure of contaminant reduction, this appears to have been attributable primarily to solubilization of contaminants, separation of fine solids, and volatilization than to contaminant destruction through the cavitation/oxidation process (Table 34, Figure 45). The mass of solids lost to the wastewater stream (centrate solids) ranged from approximately 9 to 18% of incoming sediment mass. The data indicate that the cavitation/oxidation process is only marginally effective in destruction of organic contaminants. For the 2006 demonstration, experimental results demonstrating the chemistry in the oxidation/cavitation process were not available and appear not to have been performed, precluding an objective technical evaluation of this treatment mechanism. The data also do not support the hypothesis that the collision chamber enhances the soil separation process over and above conventional soil washing operations.

The degree of contaminant reduction was lower for the sediment washing technology than for the thermal technologies. Based on the 2003-2004 Venice, Italy demonstration, from 2 to 16% of the incoming metals mass

was found in the treated sand fraction, and 28 to 171% was found in the post-oxidation centrifuge solids. PAH residuals in the treated sand fraction ranged from 0.41 to 1.34% of the incoming PAH mass, and ranged from 48.4 to 124% in the post-oxidation centrifuge solids. Total PAH mass unaccounted for in the overall process ranged from zero to 49.9 percent. This efficiency may be sufficient for selected applications and treatment of sediment that is not highly contaminated. Treatment efficiency may possibly be improved with recycling of the material through the plant to achieve additional treatment, as was done at bench scale for Housatonic River sediments, where three treatment cycles were required to achieve low

Table 34. BiogenesisSM - Material and contaminant mass as percent of incoming sediment feed mass – Venice demonstration mass balance.

Batch No.	Process water	Sand fraction	Fine fraction	Centrate solids	Wastewater	Destroyed/ Unaccounted for
Solids						
Batch 1	0.00	4.01	87.4	8.60	0.00	0.00
Batch 2	0.00	3.46	72.0	13.0	0.00	11.6
Batch 3	0.00	4.94	69.5	25.6	0.00	0.00
Batch 4	0.00	9.46	73.2	17.4	0.00	0.34
Water						
Batch 1	107	0.474	13.6	0.00	193	0.00
Batch 2	103	0.332	10.4	0.00	180	11.8
Batch 3	93	0.534	14.1	0.00	178	0.00
Batch 4	147	1.17	10.5	0.00	236	0.00
Metals						
Batch 1	0.00	2.00	53.4	16.6	35.3	0.00
Batch 2	0.00	0.859	27.7	56.1	20.7	0.00
Batch 3	0.00	3.13	75.3	37.5	28.3	0.00
Batch 4 ^a	0.00	16.3	171	289	189	0.00
PAH						
Batch 1	0.00	0.651	63.4	3.81	0.11	32.0
Batch 2	0.00	0.449	48.5	1.05	0.228	49.9
Batch 3	0.00	0.409	50.3	4.20	0.006	45.1
Batch 4 ^a	0.00	1.34	124	45.7	0.033	0.00
^a Batch 4 metals mass balance significantly exceeds 100% in solids and wastewater, even though the solids and water mass balance closed relatively well. Results are considered unreliable for this test.						

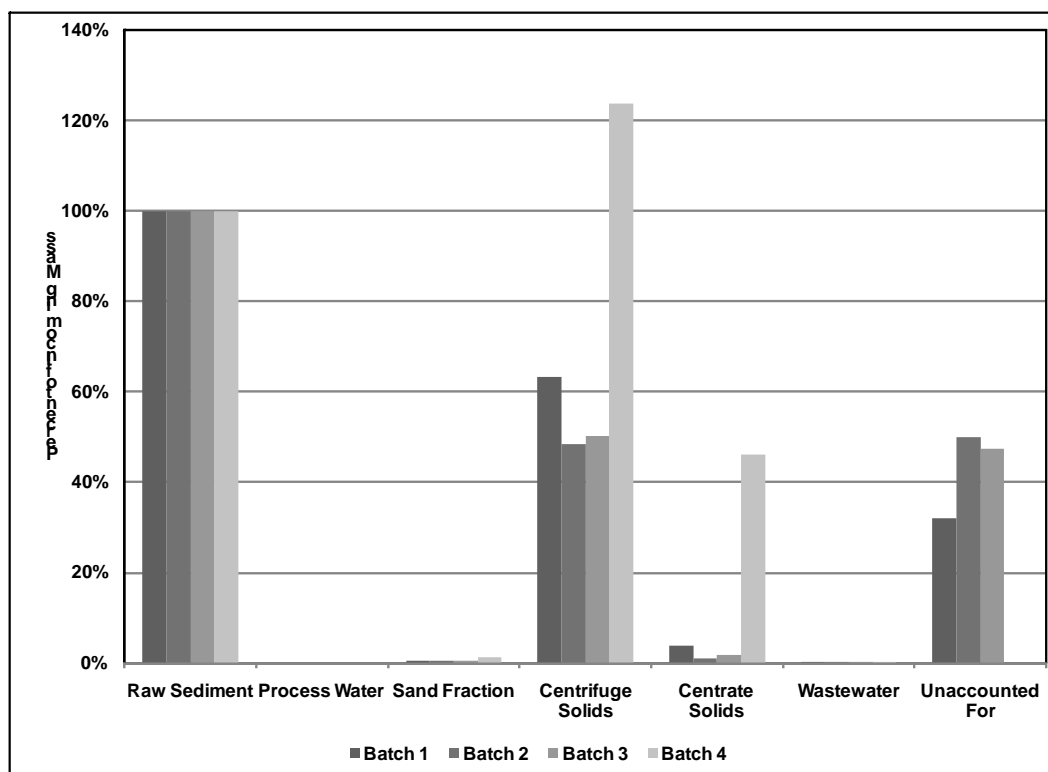

Figure 45. BiogenesisSM PAH mass as a percentage of incoming PAH mass in raw sediment – Venice Demonstration mass balance.

residual PCB concentrations; increased residence time, energy and water use, and operating costs would be required. Additional bench testing was done on Passaic River sediments (Biogenesis Washing BGW, LLC, and MHW America, Inc., 2009) to evaluate flotation for removal of PAH-contaminated detritus not effectively removed by the existing process. PAH concentrations in the treated sediment were approximately 52% of concentrations in the incoming sediment for the bench tests. This type of process could be necessary for sediments containing a coarse organic fraction as well.

Because phase transfer and particle separation are the principal mechanisms of removal for metals and for at least a portion of the organic contaminants in the sediment washing technology, the wastewater stream is anticipated to be contaminated, requiring additional treatment prior to discharge. The most recent configuration for the Biogenesis technology includes a wastewater treatment train consisting of clarification, sand filtration, and carbon adsorption. Some of the wastewater can be recycled, reducing the wastewater volume released to a public sewer or a waterway. Although the thermal technologies do require sediment dewatering, the dewatering step at the end of the BiogenesisSM process would generate a

comparable volume, in addition to the water added during the process. The mass of water added during treatment with the BiogenesisSM process (Venice demonstration, Biogenesis Italia, LLC, MHW Americas, Inc. and Jan de Nul, N.V. 2005) ranged from 93 to 107% of the water contained in the raw sediment, and the wastewater stream ranged from 178 to 236% by mass of the water contained in the raw sediment.

For the thermal technologies, total wastewater mass associated with gas scrubbing operations ranged from zero to 11%. Water associated with the off-gas streams, including dryer condensate, ranged from approximately 90% of the Minergy process to 200% for Rotary Kiln. It is not known how the dryer condensate would be managed in a full-scale operation, whether it would be discharged to the atmosphere or condensed and managed as part of the wastewater stream. For both Minergy and Rotary Kiln, wastewater mass associated with gas scrubbing was approximately 10% of incoming water mass in the sediment. No wastewater volume was reported for Cement-Lock[®].

The most appropriate technology type for a given site will require careful evaluation of the efficiency achievable for a given suite of contaminants and bulk sediment concentrations relative to the efficiency required to meet treatment objectives. The technical evaluation should be coupled with careful cost analysis, taking into account all of the processes integral to the operation, including costs associated with pre-treatment and management of the residuals. Given the costs of these demonstrations, it is uncertain whether pilot testing would be possible as part of a treatment alternatives analysis; however, the largest-scale feasibility testing possible should be conducted. Because contaminated sediments generally contain multiple contaminants, achieving equal efficiency for all contaminants is particularly challenging. PAHs proved to be recalcitrant to the sediment washing technology although improved methods of separating natural organic material from the sediment were identified in subsequent bench testing (Biogenesis Washing BGW, LLC, and MHW Americas, Inc., 2009). Combining treatments could offer some promise in terms of increasing overall treatment efficiency, but the aggregate cost would likely further challenge the economics of the process.

Each of the treatment technologies require some level of pre-treatment, and generate unique waste streams that have generally received little consideration. At pilot scale, waste is not highly significant, but at full

scale, waste management is likely to add substantially to the complexity and cost of sediment treatment. Assuming the untreated waste can be discharged to the environment or sent to a publicly owned treatment facility is likely to grossly underestimate the cost of sediment treatment, should those assumptions prove false. In addition to a landfill tipping fee, the transportation costs for hauling debris and other residual solids to a landfill or disposal site cannot be discounted.

7 Conclusions

Maximum scale of demonstrations to date:

- 11,000 m³ (15,000 yd³) maximum total sediment volume processed
- 2,000 m³ (2,700 yd³) maximum volume processed on continuous basis
- 3 days longest continuous operating time at maximum rate with validation data
- 30 m³/hr 40 yd³/hr maximum demonstrated processing rate

Processing Issues

- Feed preparation is required. Debris and oversize removal, dewatering, and drying are required for thermal processes. Debris and oversize removal are required for the sediment washing process. Pre-treatment processes were not well-documented for any of the processes, in either the technical evaluation or the cost estimates.
- Water content must be optimized in the feed for the thermal processes. Blending may be required to facilitate handling of dried materials, so that they are flowable rather than sticky or lumpy.
- Site-specific sediment variability may dictate different equipment within a process and/or different operating conditions. Flexibility must be an attribute of process design.
- Unavailability of well-matched pilot scale equipment was somewhat limiting and problematic. Not all equipment-related processing issues were resolved in pilot scale demonstrations, but presumably can be addressed with equipment designed to specification for full-scale operations.
- Disparity of dredge production rate to treatment capacity is still potentially a significant issue. While the capacity of the plants proposed for full scale may be sufficient to handle the annual production of dredged material for a given project, it is likely that the material will be dredged at a higher rate than it can be treated without cost-prohibitive scaling up of the treatment plants. Staging and storage areas and material rehandling will likely be required so that dredging and treatment rates are not interdependent.

Treatment Efficiency/Effectiveness

- There are different ways of expressing process and treatment efficiency, each of which addresses a different aspect of treatment feasibility:
 - *Overall efficiency* takes into account residual contaminants in product and all waste streams. Overall process efficiency must be understood to assess the cost to manage waste streams and the environmental impact of a treatment process.
 - *Stage efficiency* considers contaminant reduction occurring in a single unit operation. Stage efficiency is important in determining which treatment mechanisms are operative and the benefit associated with a specific unit operation. Stage efficiency may also be helpful in troubleshooting a process that is failing to meet treatment objectives.
 - *Decontamination efficiency* considers only contaminant reduction in a product relative to feed. Decontamination efficiency is important in assessing whether treatment goals are met with the product.
- Multiple mechanisms of treatment were evident with all processes evaluated, including volatilization, contaminant destruction, phase transfer, and particle separation. Volatilization was particularly important for mercury, and also for PAHs in some instances. Mechanisms of removal must be understood in order to assess process efficiency and magnitude and character of residual waste streams.
- Some degree of contaminant reduction was achieved with all treatment technologies. Only the thermal technologies were highly efficient in treating sediment. The physical-chemical treatment technology exhibited relatively low overall efficiency because of the affinity of chemical contaminants for sediment particles and organic matter and the competition from natural organic matter for process chemicals; chemical oxidation was not shown to be very effective in treatment of organic compounds. However, achieving target cleanup levels may not require high efficiency in some cases.
- There are multiple approaches to assessing treatment effectiveness – concentration, mass balance, and destruction and removal efficiency DRE. Simple concentration comparisons can be misleading both in terms of what is happening within the process and with respect to the overall process efficiency. A complete mass balance is the only definitive way of assessing treatment performance by fully accounting for both contaminants and materials entering and leaving the process.

- TCLP measured on a product without parallel testing of untreated sediment is not a complete evaluation; the change in leachability can only be assessed if the initial condition is known. Measuring only leachable concentrations on a product is also insufficient to close the mass balance; total residual concentrations in the product are also required. Although the TCLP is commonly used as a measure of contaminant mobility for regulatory purposes, it has limited value for most beneficial uses because the conditions of the test are not representative. Alternative leaching tests are available in the literature and their use should also be considered.
- Collecting all the data necessary for a complete materials and contaminant mass balance is a formidable task for a field project, particularly for thermal processes that include vaporization of water and combustion products. Cement-Lock[®] provided the most complete mass balance reporting but some estimation of material flows was still required. Most of the technology reports do not do an adequate job of accounting for material and contaminant fate, and most of the documentation was supported by a relatively small number of replicate analysis or measurements. In a number of cases, a consistent set of analytes was not evaluated on all waste streams, limiting the extent to which contaminant fate could be determined. Considerable variance in the process data may be attributable to analytical and sampling imprecision, concentrations at or below reporting limits, sediment variations and lack of steady state conditions.

Cost

- Differences in business models and cost basis make side-by-side comparison of treatment costs for each of these processes difficult.
- The revenues that could be expected from the sale of beneficial use product are somewhat speculative at this point and will require locale specific verification and market acceptance. Generally, these values are based on market value of competing materials that are not associated with the presence of contaminants, and they assume that the market needs more of these products at the current price. A performance history will have to be established before the full value of the beneficial use products can be realized.
- “Reliable cost estimates are developed only through experience that comes from execution and observation of *full-scale* remediation” (Thompson and Francingues 2001). Cost estimates provided by the

- vendors were based on small-scale demonstrations, and are therefore subject to some uncertainty.
- As part of this effort, an attempt was made to establish a comparable basis for estimating unit costs for each technology. These estimates provide a frame of reference for cost of treatment based on the best information available at the time and the level of rigor achievable within the scope of the effort. These cost estimates are intended to inform potential technology users of the limitations of the cost estimates included as part of the vendor and government technology reports, provide insights into the influence of factors not considered in the vendor cost estimates, and provide a tool potentially useful for future technology screening efforts.
 - One of the nine CERCLA feasibility study criteria for remediation alternatives analysis is “reduction of toxicity, mobility, volume through treatment” (USEPA 1988). The viability of sediment treatment is questionable, however, given that other alternatives are being used at the sediment megasites such as New Bedford Harbor, Hudson River, and Fox River (National Research Council (NRC) 2007). The need for a consistent feed supply favors a mobile process, but the need for high capacity favors a larger facility that would not likely be mobile. A non-mobile facility would have to be decommissioned or retooled at project completion if alternative feed sources were not available, thus forcing the capitalization cost of the equipment to be absorbed by a single project. The technologies under consideration require significant capital investment for specialized equipment such as kilns; the larger the scale, the more substantial the investment. From a business perspective, these considerations constitute key commercialization barriers.
 - The technology user should be wary in reviewing cost estimates based on weight versus volume. Water content and particle density affect the conversion. Dewatered sediment is evaluated differently than in situ sediment. Cost comparisons of different technologies should be made on the same volume or mass basis for the material “as it lies,” whether that is in situ or in a stockpile, for example. The cost of pre-treatment required to prepare that material as a feedstock must also be taken into account.

Looking forward

Is there a future for sediment treatment technologies in the United States? The answer to this question depends on economic conditions and

technology effectiveness. Treatment technologies that can economically compete with conventional disposal will survive if they also can consistently and substantially reduce public and environmental risks associated with sediment contaminants. This is a challenging prospect because, as noted earlier, conventional disposal is typically a cheaper option than treatment. However, this will remain the case only so long as landfill space is plentiful and existing CDFs can accommodate additional sediment. The public certainly has a vested interest in the development of creative and more sustainable alternatives to disposal. Treatment technologies offer just such a sustainable approach, with the promise of reducing contaminated sediment volumes, recycling treated sediment, and decreasing landfill expansion.

Future investment should be based on fact-based screening that objectively evaluates technology performance and costs. It is clear from the level of effort required to complete this review that technology evaluation guidelines to establish greater continuity, accountability, and transparency of process documentation can be improved. A consistent reporting structure that can be expediently audited, and readily understood, is needed. Cost estimates must have a uniform basis and independent verification. Lack of thoroughness and transparency makes it difficult for technology consumers to make appropriate assessments or to buy in with confidence. Ultimately, this has worked against the science, the technologies, and the consumer.

References

- American Society for Testing and Materials (ASTM). 1999. *Standard Test Method for Shake Extraction of Solid Waste with Water*. West Conshohocken, PA.
- Averett, D.E., B.D. Perry, E.J. Torrey, and J.A. Miller. 1990. *Review of removal, containment, and treatment technologies for remediation of contaminated sediments in the Great Lakes*. Miscellaneous Paper EL-90-25. Vicksburg, MS: U.S. Army Corps of Engineers Waterways Experiment Station, prepared for U.S. Environmental Protection Agency - Great Lakes National Program Office, Chicago, IL.
- Beerkens, R. G. 2002. *Modeling of the melting process in industrial glass furnaces*. Chapter 2.1, in *Mathematical simulation in glass technology*, ed. D. Krause, and H. Loch, 17-72 Berlin: Springer.
- Biogenesis Enterprises, Inc., and Roy F. Weston, Inc. 1999. *BiogenesisSM Sediment Washing Technology Full Scale, 40 yd³/hour, Sediment decontamination Facility for the NY/NJ Harbor Region*. Final Report on the Pilot Demonstration Project. Springfield, VA. Submitted to Brookhaven National Laboratory, Upton, NY.
- Biogenesis Italia, LLC, MHW Americas, Inc., and Jan de Nul, N.V. 2005. *Pilot Scale Demonstration Project of the BiogenesisSM Sediment Decontamination Process, Autorità Portuale di Venezia, Porto Marghera, Venice, Italy*. Springfield, VA.
- BioGenesis Enterprises, Inc. 2008. *BiogenesisSM Sediment washing Technology, Bench Scale Treatability Study Report Housatonic River–Rest-of-River Site*. Springfield, VA. Final report to ARCADIS, Syracuse, NY.
- BioGenesis Washing BGW, LLC, and MHW Americas, Inc. 2009. *Demonstration Testing and Full-Scale Operation of the BioGenesisSM Sediment Decontamination Process – Final Report*, December 17, 2009, Springfield, VA.
- Brandon, D. L., and R. A. Price. 2007. *Summary of Available Guidance and Best Practices for Determining Suitability of Dredged Material for Beneficial Uses*. ERDC/EL TR-07-27. Vicksburg, MS: U.S. Army Engineer Research and Development Center.
- Great Lakes Commission. 2004. *Testing and evaluating dredged material for upland beneficial uses: a regional framework for the Great Lakes - Second Edition September 2004*. Ann Arbor, MI. http://www.glc.org/upland/download/UplandFramework_2.pdf
- Interstate Technology and Regulatory Council. 2005. *Examination of risk-based screening values and approaches of selected states*. Washington, DC.

- JCI/Upcycle Associates, LLC 2002. *Final Summary Report, Sediment Decontamination and Beneficial Use Pilot Project*. Prepared for New Jersey Department of Transportation, Office of Maritime Resources, Project AO#9350203 and United States Environmental Protection Agency – Region 2, through Brookhaven National Laboratory, Contract Number 48172, Upton, NY.
- McLaughlin, D. F., S. V. Dighe, D. L. Keairns, and N. H. Ulerich. 1999. Decontamination and beneficial reuse of dredged estuarine sediment: The Westinghouse plasma vitrification process. *19th Western Dredging Association (WEDA XIX) Annual Meeting and Conference and 31st Texas A&M University Dredging Seminar (TAMU 31)*. Louisville, KY, May 15-20, 1999. (PDF file).
- Mensingher, M. C., and T. R. Sheng. 2006. *Demonstration Program: Cement-Lock® Technology Phase I Pilot Test*. Final Report to New Jersey Department of Transportation, Office of Maritime Resources. Trenton, NJ.
- Mensingher, M. C. 2008a. *Sediment Decontamination Demonstration Program – Cement-Lock® Technology, Final Report: Phase II demonstration tests with Stratus Petroleum and Passaic River sediments*. Prepared under subcontract to ENDESCO Clean Harbors by Gas Technology Institute for NJDOT, Office of Maritime resources, Trenton, NJ, and USDOE, Brookhaven Science Associates, LLC, Upton, NY.
- Mensingher, M. C. 2008b. *Cement-Lock® technology for decontaminating dredged estuarine sediments, Final Project Report*. GTI Project Number 15372. November.
- Minergy Corporation. 2002. *Final report sediment melter demonstration project*. Prepared for Wisconsin Department of Natural Resources. Madison, WI.
- Minergy Corporation. 2003a. Revised Unit Cost Study for Commercial-Scale Sediment Melter Facility, Glass Furnace Technology. Prepared for Wisconsin Department of Natural Resources, Madison, Wisconsin.
- Minergy Corporation. 2003b. *Supplemental sediment handling characterization report—Glass furnace technology*. Prepared for Wisconsin Department of Natural Resources. Madison, WI.
- Minergy Corporation. 2003c. *Sediment melter demonstration project*. Final report prepared for Wisconsin Department of Natural Resources, Madison, WI.
- National Research Council (NRC). 1997. *Contaminated Sediments in Ports and Waterways*. National Research Council. National Academy of Press, Washington, DC. <http://www.nap.edu/bookstore.html>.
- National Research Council (NRC). 2007. *Sediment dredging at superfund megasites—assessing the effectiveness*. The Committee on Sediment Dredging at Superfund Megasites. Washington, DC: The National Academies Press.
- New Jersey Department of Transportation (NJDOT). 2004. *Sediment Decontamination Technology Demonstration Program Project Update for Upcycle Associates, LLC, Last Updated: February, 2004*. Office of Maritime Resources. <http://www.nj.gov/transportation/airwater/maritime/pdf/upcycleupdate.pdf>

- New Jersey Department of Transportation (NJDOT). 2010. *Sediment Decontamination Technology Demonstration Program—Harbor Resource Environmental Group*. Office of Maritime Resources. <http://www.state.nj.us/transportation/airwater/maritime/dresediment.shtm> (Accessed 28 Apr 2010).
- New York State Department of Environmental Conservation. 2006. Subpart 375-6: Remedial Program Soil Cleanup Objectives. <http://www.dec.ny.gov/regs/15507.html> (Accessed June 28, 2010).
- Palermo, M.R., P. R. Schroeder, T. J. Estes, and N. R. Francingues. 2008. *Technical guidelines for environmental dredging of contaminated sediments*. ERDC/EL TR-08-29. Vicksburg, MS: U.S. Army Engineer Research and Development Center.
- Rehmat, A., A. Lee, and M. C. Mensinger. 1999a. *Cement-Lock™ Technology for Decontaminating Dredged Estuarine Sediments*. Final Report to Des Plaines, IL: Brookhaven National Laboratory. Phase II: Pilot-Scale Studies. Institute of Gas Technology.
- Rehmat, A., A. Lee, A. Goyal, M. C. Mensinger. 1999b. Construction-grade cement production from contaminated sediments using Cement-Lock® Technology. In *Proceedings of the Western Dredging Association 19th Technical Conference and 31st Texas A&M Dredging Seminar, (16-18 May 1999, Louisville, Kentucky)*, ed. R. E. Randall, CDS Report No. 371:555-566. College Station, TX: Texas A&M University Center for Dredging Studies.
- Rowe, M. D., R. C. Klein, and K. W. Jones. 1999. *Preliminary evaluation of potential occupational and public health impacts of sediment decontamination facilities for New York/New Jersey Harbor*. Upton, NY: US Department of Energy Brookhaven National Laboratory.
- Seager, T. P., and K. H. Gardner. 2005. Barriers to adoption of novel environmental technologies: Contaminated sediments. In *Strategic Management of Marine Ecosystems: Proceedings of the NATO Advanced Study Institute, (1-11 October, 2003) Nice, France*, (NATO Science Series: IV. Earth and Environmental Sciences) ed. E. Levner, I. Linkov, and J. M. Proth. New York: Springer: ISBN 1-402-03157-2, 298-312.
- Stern, E. A., K. W. Jones, W. S. Douglas, H. E. Feng, N. L. Clesceri. 2009. New York/New Jersey Ex Situ Sediment Decontamination Program (1994-2008). In *Remediation of Contaminated Sediments—2009. Proceedings of the Fifth International Conference on Remediation of Contaminated Sediments February 2–5, 2009 Jacksonville, Florida*. G.S. Durell and E.A. Foote (Conference Chairs), Battelle Memorial Institute, Columbus, OH. www.battelle.org/sedimentscon
- Thompson, D., and N. R. Francingues. 2001. A special report on PIANC's innovative dredged sediment decontamination and treatment technologies specialty workshop. *Journal of Dredging Engineering*, 3(2):1-31. Western Dredging Association.
- U.S. Army Corps of Engineers (USACE) (IWR). 2010. Navigation Data Center—Dredging Program. Institute for Water Resources (IWR), Alexandria, VA. <http://www.ndc.iwr.usace.army.mil/dredge/dredge.htm>

- U.S. Army Corps of Engineers (USACE), Institute for Water Resources (IWR). FY 2009 analysis of dredging costs—Actual amounts for FY 2009. <http://www.ndc.iwr.usace.army.mil/dredge/dd09cos2.htm> (accessed August 13, 2010), Alexandria, VA: U.S. Army Corps of Engineers Navigation Data Center, 2010.
- U.S. Environmental Protection Agency (USEPA). 1988. *Guidance for Conducting Remedial Investigations and Feasibility Studies under CERCLA*. EPA-540-G-89-004. Washington, DC.
- U.S. Environmental Protection Agency (USEPA). 1992. Assessment and Remediation of Contaminated Sediments (ARCS) Program Work Plan. USEPA Great Lakes National Programs Office, Chicago, IL. <http://www.epa.gov/grtlakes/arcs/ARCS-92-Workplan/ARCS-Workplan.html#Engineering>
- U.S. Environmental Protection Agency (USEPA). 1994. *Assessment and Remediation of Contaminated Sediments (ARCS) Program Remediation Guidance Document*. EPA/905/R-94/003. Chicago, IL: U.S. Environmental Protection Agency Great Lakes National Program Office. <http://www.epa.gov/grtlakes/arcs/EPA-905-B94-003/EPA-905-B94-003.html>
- U.S. Environmental Protection Agency (USEPA). 1996. *Test Methods for Evaluating Solid Waste, Physical/Chemical Methods, Laboratory Manual, Volume 1A through 1C, and Field Manual, Volume 2. SW-846, Third Edition, Final (Promulgated) Update III*. Office of Solid Waste, EPA Document Control No. 955-001-00000-1.
- U.S. Environmental Protection Agency (USEPA). 2004. *Minergy Corporation Glass Furnace Technology Evaluation -Innovative Technology Evaluation Report*. EPA/540/R-03/500. Cincinnati, OH: National Risk Management Research Laboratory Office of Research and Development U.S. Environmental Protection Agency.
- U.S. Environmental Protection Agency (USEPA). 2005. *Contaminated sediment remediation guidance for hazardous waste sites*. EPA-540-R-05-012, OSWER 9355.0-85. Washington, DC: Office of Solid Waste and Emergency Response.
- U.S. Environmental Protection Agency (USEPA)-Region II, U.S. Army Corps of Engineers (USACE)-New York District, and USDOE-BNL, 1999. *Fast track dredged material decontamination demonstration for the Port of New York and New Jersey*. Draft Report to Congress on the Water Resources and Development Acts of 1990 (Section 412), 1992 (Section 405C), and 1996 (Section 226). <http://www.bnl.gov/wrdadcon/publications/reports/Congress.pdf>
- U.S. Environmental Protection Agency (USEPA). 2003a. *Technology Profiles Eleventh Edition Volume 1*. Demonstration Program (EPA/540/R-03/501). National Risk Management Research Laboratory, Office of Research and Development, Cincinnati, OH. <http://www.epa.gov/nrmrl/lrpcd/site/techprofiles.html#cd>
- U.S. Environmental Protection Agency (USEPA). 2003b. *Technology Profiles Eleventh Edition Volume 2*. Emerging Technology Program (EPA/540/R-03/501A). National Risk Management Research Laboratory, Office of Research and Development, Cincinnati, OH. <http://www.epa.gov/nrmrl/lrpcd/site/techprofiles.html#cd>

U.S. Environmental Protection Agency (USEPA). 2003c. *Technology Profiles Eleventh Edition Volume 3. Measurement and Monitoring Program (EPA/540/R-03/501B)*. National Risk Management Research Laboratory, Office of Research and Development, Cincinnati, OH.

<http://www.epa.gov/nrmrl/lrpcd/site/techprofiles.html#cd>

U.S. Environmental Protection Agency (USEPA). 2010. *Contaminated Sediments in Superfund--Data on Superfund Sediment Sites*. Office of Solid Waste and Emergency Response—Superfund.

<http://www.epa.gov/superfund/health/conmedia/sediment/data.htm>

Appendix A: Major Technology Development Programs

To understand the maturity or lack thereof regarding sediment treatment, a review of the history and timeline of technology development was undertaken. The majority of technical development appears to have been conducted under one of the four following programs:

- Superfund Innovative Technology Evaluation (SITE) Program
- Assessment and Remediation of Contaminated Sediment (ARCS) Program
- Contaminated Sediment Treatment Technology Program (CoSTTEP)
- Water Resources Development Act (WRDA) Sediment Decontamination Demonstrations.

Table A1 illustrates the years in which sediment treatment research was conducted under these programs. The shaded areas indicate the years of most intensive activity for the SITE and WRDA Programs, and the years of the ARCS Program in its entirety. Technically the SITE program was funded through 2006, but as far as could be determined, no substantive work with sediments appears to have been done under this program beyond the mid 1990's. Work that continues under WRDA funding is mostly associated with that being done in conjunction with the New York/New Jersey harbor. Some treatability studies are being conducted in conjunction with remedial site investigations, however, as is discussed later. The following provides a short synopsis of each of the four major programs.

Table A1. Sediment treatment research and development programs

Program	1986	1987	1988	1989	1990	1991	1992	1993	1994	1995	1996	1997	1998	1999	2000	2001	2002	2003	2004	2005	2006	2007	2008
SITE	•	•	•	•	•	•	•	•	•	•	•	•	•	•	•	•	•	•	•	•			
ARCS																							
WRDA																							
CoSTEP																							

Note: Bullets indicate program activity; shaded areas indicate periods of more intensive activity.

Contaminated Sediment Treatment Technology Program (CoSTTEP)

Canada and the United States signed the Great Lakes Water Quality Agreement in 1972. The two governments established 43 Areas of Concern (AOC) on the Great Lakes. Remedial Action Plan (RAP) teams were formed to devise a cleanup plan for each AOC. Environment Canada's Great Lakes 2000 Cleanup Fund was created to assist the RAP teams. The Cleanup Fund managers developed several innovative programs to fill the information gaps in the area of contaminated sediment remediation. One of these programs was CoSTTEP. CoSTTEP fosters the development and demonstration of "ex-situ" technologies to remediate contaminated sediments.

Assessment and Remediation of Contaminated Sediment (ARCS) Program

The ARCS Program conducted demonstration projects related to the control and removal of toxic pollutants from bottom sediments. One element of the ARCS program was a review of technical literature and databases for previous technology assessments/demonstrations (Averett et al. 1990). The objectives of the ARCS Program were to:

- (1) Assess the nature and extent of bottom sediment contamination at selected locations within the US Great Lakes
- (2) Evaluate and demonstrate remedial options including immobilization, advanced treatment technologies and the "No Action" alternative
- (3) Provide guidance to various levels of government in the United States and Canada in the implementation of Remedial Action Plans for locations within their jurisdiction

Thirteen treatment technologies were demonstrated at bench or pilot scale (Table A2) under the ARCS Program USEPA 1992

(<http://www.epa.gov/grtlakes/arcs/ARCS-92-Workplan/ARCS-Workplan.html#Engineering>).

Table A2. Technologies demonstrated under the ARCS Program

Technology	Scale	
	Bench	Pilot
Solidification/Stabilization	X	X
Inorganic Treatment Recovery	X	X
Bioremediation	X	X
Base Catalyzed Decomposition (BCD) (Formerly called KPEG Nucleophilic Substitution)	X	
Basic Extraction Sludge Technology (BEST) Extraction Process	X	X
Low Temperature Thermal Stripping	X	X
Wet Air Oxidation	X	
Low Energy Extraction	X	
Eco-Logic Destruction Process	X	
In-Situ Stabilization	X	X
Acetone Extraction (Rem-Tech)	X	
Aqueous Surfactant Extraction	X	
Sediment Dewatering Methods	X	

Superfund Innovative Technology Evaluation (SITE) Program

The Superfund Innovative Technology Evaluation (SITE) program was established by EPA's Office of Solid Waste and Emergency Response and the Office of Research and Development in response to the Superfund Amendments and Reauthorization Act of 1986. The program was intended to accelerate the development and use of (1) innovative treatment technologies for hazardous waste site remediation, and (2) characterization and monitoring technologies for evaluating the nature and extent of hazardous waste site contamination. The SITE Program included the following key components: (i) Demonstrations Program (120 technologies evaluated, 16 used in ongoing projects), (ii) Emerging Technology Program (70 technologies evaluated, 7 used in ongoing projects), (iii) Monitoring and Measurement Technologies (45 technologies evaluated), and (iv) Information Transfer Activities (USEPA 2003a,b,c). Additional information can be obtained from the following link: <http://www.epa.gov/nrmrl/lrpcd/site/index.html>. The 2006 fiscal year was the final year of the program.

Water Resources Development Act (WRDA)

Elements of the Water Resources Development Act (WRDA) were enacted in 1986, 1990, 1992, and 1996. The WRDA of 1990 required the

development of a program for monitoring the physical, chemical, and biological effects of dredged material disposal and the creation of a demonstration project for disposing of material dredged in an environmentally sound manner other than by ocean disposal. Environmentally sound alternatives included capping of borrow pits, construction of a containment island, application for landfill cover, habitat restoration, and use of decontamination technology. The WRDA of 1992 authorized the USEPA, with the cooperation of the Army Corps of Engineers, to review the decontamination technologies recommended pursuant to the 1990 Act and select the best technologies to treat dredged material. The WRDA Act of 1996 added a new subsection to the 1990 Act describing the pilot program, increased the funds for the project, and added a new subsection requiring the preparation of periodic reports on the status of the decontamination technology project. The USEPA Region 2, USACE New York District, and US Department of Energy Brookhaven National Laboratory (1999) interim report to Congress sets forth the major accomplishments under WRDA. Technologies evaluated under the WRDA program are listed in Table A3. Additional information can be obtained from the following link:

<http://www.bnl.gov/wrdadcon/wrda/wrda.htm>.

Table A3. Technologies demonstrated under the WRDA program (USEPA Region 2, USACE NY District, and BNL)

Technology	Scale		
	Bench	Pilot	Full
Rotary kiln/Cement-Lock® (Institute of Gas Technology/ENDESCO)	X	X	X
Sediment washing (Biogenesis SM)	X	X	X
Plasma torch vitrification (Westinghouse)	X	X	
Solvent extraction (Metcalf and Eddy)	X	X	
Thermal desorption (International Technology Corporation)	X		
Base catalyzed decomposition (BCD)/thermal desorption (Batelle)	X		
Fluidized bed thermal treatment (Biosafe)	X		
Manufactured soil	X	X	
Solidification/stabilization (Marcor)	X		

New Jersey Department of Transportation's Office of Maritime Resources (NJDOT/OMR) Sediment Technology Decontamination Demonstration Program

Using funds provided from the Harbor Revitalization and Dredging Bond Act of 1996 and the Joint Plan for Dredging in the Port of NY and NJ, the New Jersey Department of Transportation's Office of Maritime Resources (NJDOT/OMR) has evaluated, tested, and promoted alternatives to ocean disposal of dredged materials. Sediment decontamination technology is one alternative under consideration. This program is a companion program to the WRDA program focusing on NY/NJ Harbor. The following technologies have been included in the program:

<http://www.state.nj.us/transportation/airwater/maritime/dresediment.shtml>

- Thermal destruction to manufacture lightweight aggregate (Upcycle Associates, LLC),
- Thermal destruction to manufacture blended cement (ENDESCO Clean Harbors, LLC),
- Sediment washing and chemical destruction (BGW, LLC and NUI Environmental Group), and
- Enhanced mineralization/chemical destruction (BEM Systems, Inc.).

Summary

Despite the progress made, issues still remained impeding full-scale implementation and commercialization, including:

- Limited demonstrated scale
- Persistent logistical issues
- Cost uncertainty
- Public acceptance
- Institutional constraints

In 2007, however, two larger scale demonstrations were conducted in conjunction with the Passaic River remedial investigation. These offered the opportunity for a significant step towards commercialization for the two technologies evaluated (BiogenesisSM and Cement-Lock[®]). Those demonstrations are discussed in more detail in this report.

Appendix B: JCI/Upcycle Rotary Kiln Mass Balance

The enclosed tables support mass balance calculations reflected in the following:

- Chapter 2
 - Tables 4 and 5
 - Figures 3 and 4
- Chapter 3
 - Table 17
 - Figures 14-18
- Chapter 6
 - Table 33
 - Figure 44

Appendix B: Rotary Kiln Mass Balance

Process Stream	Filter Cake Into Hammermill Dryer		Hammermill Dryer To Baghouse	
Stream Number	1		2	
Units	LBS		LBS	
Total Mass	6,504		4,007	
Percent Moisture	57.0%		89.8%	
Dry Mass Solids	2,797		410	
Mass Water	3,707		3,597	
Source of Mass	Values given in bold (also blue text) are from JCI Upcycle (2002)			
Source of Moisture Content	Values given in bold (also blue text) are from JCI Upcycle (2002)			
Source of Chemical Info	Values given in bold (also blue text) are from JCI Upcycle (2002)			
Other notes			Dryer Time	11.60
	Conc¹	Mass	Conc	Mass
	mg/kg	lb	lb/hr	lb
METALS				
Aluminum	15,900	4.45E+01		
Arsenic	18.2	5.09E-02		
Barium	123	3.44E-01		
Cadmium	3.2	8.95E-03		
Chromium	180	5.03E-01		
Copper	178	4.98E-01		
Iron	40,700	1.14E+02		
Lead	185	5.17E-01		
Magnesium	9,220	2.58E+01		
Manganese	696	1.95E+00		
Mercury	3.80	1.06E-02		
Nickel	43.2	1.21E-01		
Potassium	3,010	8.42E+00		
Selenium	0.680	1.90E-03		
Silver	4.1	1.15E-02		
Zinc	300	8.39E-01		
Total Metals		196.51		
PAHs				
Anthracene	0.037	1.03E-04		
Benzo(a)anthracene	0.065	1.82E-04		
Benzo(b)fluoranthene	0.085	2.38E-04		
Benzo(k)fluoranthene	0.394	1.10E-03		
Benzo(a)Pyrene	0.098	2.74E-04		
Bis(2-ethylhexyl)phthalate	0.325	9.09E-04		
Chrysene	0.135	3.78E-04		
Fluoranthene	0.205	5.73E-04		
Naphthalene	0.144	4.03E-04		
Phenanthrene	0.049	1.37E-04		
Pyrene	0.150	4.20E-04		
Total PAHs		3.81E-03		
PESTICIDES				
gamma-BHC (Lindane)	0.00022	6.15E-07		
4,4'-DDE	0.00098	2.74E-06		
4,4'-DDD	0.00093	2.60E-06		
4,4'-DDT	0.00106	2.96E-06		
PCBs				
Total PCBs	0.144	4.03E-04		
OTHER				
Total Chlorine		0.00E+00		
OCDD	0.00535	1.50E-05		
OCDF	0.00155	4.33E-06		
SO2				
NO2				
CO				
VOC				
SVOC(.C-16)				
SVOC(C-7 through C-16)				

Appendix B: Rotary Kiln Mass Balance

Process Stream	Offgas Beyond Baghouse		Baghouse Solids	
Stream Number	3		4	
Units	LBS		LBS	
Total Mass	3,598		409	
Percent Moisture				
Dry Mass Solids	1.6		409	
Mass Water	3,597			
Source of Mass				
Source of Moisture Content				
Source of Chemical Info				
Other notes	hr			
	Conc	Mass	Conc¹	Mass
	lb/hr	lb	mg/kg	lb
METALS				
Aluminum			15,900	6.50E+00
Arsenic			18.2	7.44E-03
Barium			123	5.03E-02
Cadmium			3.2	1.31E-03
Chromium			180	7.36E-02
Copper			178	7.28E-02
Iron			40,700	1.66E+01
Lead			185	7.56E-02
Magnesium			9,220	3.77E+00
Manganese			696	2.84E-01
Mercury	5.52E-05	6.40E-04	3.80	1.55E-03
Nickel			43.2	1.77E-02
Potassium			3,010	1.23E+00
Selenium			0.680	2.78E-04
Silver			4.1	1.68E-03
Zinc			300	1.23E-01
Total Metals		0.00064032		2.88E+01
PAHs				
Anthracene			0.037	1.51E-05
Benzo(a)anthracene			0.065	2.66E-05
Benzo(b)fluoranthene			0.085	3.47E-05
Benzo(k)fluoranthene			0.394	1.61E-04
Benzo(a)Pyrene			0.098	4.01E-05
Bis(2-ethylhexyl)phthalate			0.325	1.33E-04
Chrysene			0.135	5.52E-05
Fluoranthene			0.205	8.38E-05
Naphthalene			0.144	5.89E-05
Phenanthrene			0.049	2.00E-05
Pyrene			0.150	6.13E-05
Total PAHs		0.00E+00		5.57E-04
PESTICIDES				
gamma-BHC (Lindane)			0.00022	8.99E-08
4,4'-DDE			0.00098	4.01E-07
4,4'-DDD			0.00093	3.80E-07
4,4'-DDT			0.00106	4.33E-07
PCBs				
Total PCBs			0.144	5.89E-05
OTHER				
Total Chlorine				0.00E+00
OCDD			0.00535	2.19E-06
OCDF		0.00E+00	0.00155	6.34E-07
SO2	0.02	1.92E+00		
NO2	0.04	3.85E+00		
CO	0.29	2.79E+01		
VOC	0.19	1.83E+01		
SVOC(C-16)				
SVOC(C-7 through C-16)				

Appendix B: Rotary Kiln Mass Balance

Process Stream	Shale Added to Extruder		Water Added to Extruder	
Stream Number	5		6	
Units	LBS		LBS	
Total Mass	1,070		552	
Percent Moisture	0.51%			
Dry Mass Solids	1,065			
Mass Water	5.46		552	
Source of Mass				
Source of Moisture Content				
Source of Chemical Info				
Other notes				
	Conc¹	Mass	Conc	Mass
METALS	mg/kg	lb	ug/L	lb
Aluminum	7,125	7.58E+00	0	0.00E+00
Arsenic	7.22	7.69E-03	0	0.00E+00
Barium	132	1.41E-01	21	1.16E-05
Cadmium	0	0.00E+00	0	0.00E+00
Chromium	7.35	7.82E-03	0	0.00E+00
Copper	40.7	4.33E-02	64	3.53E-05
Iron	24,350	2.59E+01	12	6.62E-06
Lead	22.3	2.37E-02	0	0.00E+00
Magnesium	2,515	2.68E+00	23,800	1.31E-02
Manganese	404	4.30E-01	0	0.00E+00
Mercury	0.123	1.31E-04	0.00045	2.48E-10
Nickel	31.0	3.30E-02	0	0.00E+00
Potassium	5,930	6.31E+00	1,745	9.63E-04
Selenium	0	0.00E+00	0	0.00E+00
Silver	0	0.00E+00	0	0.00E+00
Zinc	55.1	5.87E-02	27	1.49E-05
Total Metals		4.32E+01		
PAHs				
Anthracene				
Benzo(a)anthracene				
Benzo(b)fluoranthene				
Benzo(k)fluoranthene				
Benzo(a)Pyrene	0	0.00E+00		0.00E+00
Bis(2-ethylhexyl)phthalate				
Chrysene				
Fluoranthene	0	0.00E+00		0.00E+00
Naphthalene	0	0.00E+00		0.00E+00
Phenanthrene				
Pyrene				
Total PAHs		0.00E+00		0.00E+00
PESTICIDES				
gamma-BHC (Lindane)				
4,4'-DDE				
4,4'-DDD				
4,4'-DDT				
PCBs				
Total PCBs	0	0.00E+00		0.00E+00
OTHER				
Total Chlorine	500	5.32E-01	0	0.00E+00
OCDD	0	0.00E+00		0.00E+00
OCDF	0	0.00E+00		0.00E+00
SO2				
NO2				
CO				
VOC				
SVOC(C-16)				
SVOC(C-7 through C-16)				

Appendix B: Rotary Kiln Mass Balance

Process Stream	Dried Filter Cake To Extruder		Extrudite Pellets To Kiln	
Stream Number	7		8	
Units	LBS		LBS	
Total Mass	2,497		4,119	
Percent Moisture	4.43%		16.2%	
Dry Mass Solids	2,386		3,451	
Mass Water	111		668	
Source of Mass				
Source of Moisture Content				
Source of Chemical Info				
Other notes				
	Conc¹	Mass	Conc	Mass
METALS	mg/kg	lb	mg/kg	lb
Aluminum	15,900	3.80E+01	12,300	4.24E+01
Arsenic	18.2	4.35E-02	10.8	3.73E-02
Barium	123	2.94E-01	128	4.42E-01
Cadmium	3.2	7.64E-03	1.44	4.97E-03
Chromium	180	4.30E-01	118	4.07E-01
Copper	178	4.25E-01	124	4.28E-01
Iron	40,700	9.72E+01	28,800	9.94E+01
Lead	185	4.42E-01	113	3.90E-01
Magnesium	9,220	2.20E+01	6,540	2.26E+01
Manganese	696	1.66E+00	562	1.94E+00
Mercury	3.80	8.43E-03	2.34	8.08E-03
Nickel	43.2	1.03E-01	46.0	1.59E-01
Potassium	3,010	7.19E+00	4,180	1.44E+01
Selenium	0.680	1.62E-03	0.5	1.73E-03
Silver	4.1	9.79E-03	3.4	1.17E-02
Zinc	300	7.16E-01	210	7.25E-01
Total Metals		1.68E+02		1.83E+02
PAHs				
Anthracene	0.037	8.84E-05	0.188	6.49E-04
Benzo(a)anthracene	0.065	1.55E-04	0.530	1.83E-03
Benzo(b)fluoranthene	0.085	2.03E-04	0.738	2.55E-03
Benzo(k)fluoranthene	0.394	9.41E-04	0.353	1.22E-03
Benzo(a)Pyrene	0.098	2.34E-04	0.525	1.81E-03
Bis(2-ethylhexyl)phthalate	0.325	7.76E-04	6.85	2.36E-02
Chrysene	0.135	3.22E-04	0.635	2.19E-03
Fluoranthene	0.205	4.90E-04	0.908	3.13E-03
Naphthalene	0.144	3.44E-04	0.415	1.43E-03
Phenanthrene	0.049	1.17E-04	0.235	8.11E-04
Pyrene	0.150	3.58E-04	0.878	3.03E-03
Total PAHs		3.25E-03		1.87E-02
PESTICIDES				
gamma-BHC (Lindane)	0.00022	5.25E-07	0.00000	0.00E+00
4,4'-DDE	0.00098	2.34E-06	0.00000	0.00E+00
4,4'-DDD	0.00093	2.22E-06	0.00000	0.00E+00
4,4'-DDT	0.00106	2.53E-06	0.00000	0.00E+00
PCBs				
Total PCBs	0.144	3.44E-04	0.26	8.97E-04
OTHER				
Total Chlorine		0.00E+00	3,200	1.10E+01
OCDD	0.00535	1.28E-05	0.00310	1.07E-05
OCDF	0.00155	3.70E-06	0.000885	3.05E-06
SO2				
NO2				
CO				
VOC				
SVOC(C-16)				
SVOC(C-7 through C-16)				

Appendix B: Rotary Kiln Mass Balance

Process Stream	Offgas from Kiln		Water to Scrubber	
Stream Number	9		11	
Units	LBS		LBS	
Total Mass	1,035		3,356	
Percent Moisture				
Dry Mass Solids	367			
Mass Water	668		3,356	
Source of Mass				
Source of Moisture Content				
Source of Chemical Info				
Other notes				
	Mass Rate	Mass	Conc ²	Mass
	lb/hr	lb	ug/L	lb
METALS				
Aluminum	2.15E-03	2.07E-01	-	0.00E+00
Arsenic	3.21E-05	3.09E-03	-	0.00E+00
Barium	2.11E-05	2.03E-03	21	7.05E-05
Cadmium	4.41E-05	4.24E-03	-	0.00E+00
Chromium	7.25E-05	6.98E-03	-	0.00E+00
Copper	7.85E-05	7.55E-03	64	2.15E-04
Iron	2.81E-03	2.70E-01	12	4.03E-05
Lead	1.41E-03	1.36E-01	-	0.00E+00
Magnesium	1.01E-03	9.72E-02	23,800	7.99E-02
Manganese	9.86E-05	9.49E-03	-	0.00E+00
Mercury	4.46E-05	4.29E-03	0	1.51E-09
Nickel	3.79E-05	3.65E-03	-	0.00E+00
Potassium	1.89E-03	1.82E-01	1,745	5.86E-03
Selenium	4.64E-06	4.47E-04	-	0.00E+00
Silver	2.10E-06	2.02E-04	-	0.00E+00
Zinc	3.13E-04	3.01E-02	27	9.06E-05
Total Metals		9.64E-01		8.61E-02
PAHs				
Anthracene	1.32E-07	1.27E-05		0.00E+00
Benzo(a)anthracene	0.00E+00	0.00E+00		0.00E+00
Benzo(b)fluoranthene	0.00E+00	0.00E+00		0.00E+00
Benzo(k)fluoranthene	0.00E+00	0.00E+00		0.00E+00
Benzo(a)Pyrene	0.00E+00	0.00E+00	-	0.00E+00
Bis(2-ethylhexyl)phthalate	5.65E-07	5.44E-05		0.00E+00
Chrysene	7.41E-07	7.13E-05		0.00E+00
Fluoranthene	2.45E-06	2.36E-04	-	0.00E+00
Naphthalene	2.26E-05	2.17E-03	-	0.00E+00
Phenanthrene	4.64E-06	4.47E-04		0.00E+00
Pyrene	1.05E-06	1.01E-04		0.00E+00
Total PAHs		3.04E-03		0.00E+00
PESTICIDES				
gamma-BHC (Lindane)				
4,4'-DDE				
4,4'-DDD				
4,4'-DDT				
PCBs				
Total PCBs	4.04E-06	3.89E-04	-	
OTHER				
Total Chlorine	1.18E-03	1.14E-01	-	
OCDD		0.00E+00	-	
OCDF		0.00E+00	-	
SO2	2.10E-01	2.02E+01		
NO2	1.80E-01	1.73E+01		
CO	2.50E-01	2.41E+01		
VOC	1.40E-02	1.35E+00		
SVOC(C-16)	4.39E-03	4.22E-01		
SVOC(C-7 through C-16)	1.85E-03	1.78E-01		

Appendix B: Rotary Kiln Mass Balance

Process Stream	Alkali Wastewater From Scrubber		Particles from Ceramic Collector to Disposal	
Stream Number	12		13	
Units	LBS		LBS	
Total Mass	746		11.1	
Percent Moisture			0	
Dry Mass Solids	354		11.1	
Mass Water	392			
Source of Mass				
Source of Moisture Content				
Source of Chemical Info				
Other notes			Kiln Op Time	96.23
	Conc²	Mass	Conc¹	Mass
METALS	ug/L	lb	mg/kg	lb
Aluminum	3,050	2.28E-03	19,200	2.13E-01
Arsenic	-	0.00E+00	77.1	8.56E-04
Barium	-	0.00E+00	1.87	2.08E-05
Cadmium	-	0.00E+00	134	1.49E-03
Chromium	185	1.38E-04	278	3.09E-03
Copper	517	3.86E-04	476	5.28E-03
Iron	1,320	9.85E-04	18,600	2.06E-01
Lead	111	8.28E-05	4,550	5.05E-02
Magnesium	101,000	7.53E-02	68,500	7.60E-01
Manganese	190	1.42E-04	9,880	1.10E-01
Mercury	1	4.40E-07	8.0	8.88E-05
Nickel	-	0.00E+00	146	1.62E-03
Potassium	60,300	4.50E-02	18,700	2.08E-01
Selenium	52	3.84E-05	22.7	2.52E-04
Silver	-	0.00E+00	18.1	2.01E-04
Zinc	253	1.89E-04	807	8.96E-03
Total Metals		1.25E-01		1.57E+00
PAHs				
Anthracene		0.00E+00	0	0.00E+00
Benzo(a)anthracene		0.00E+00	0	0.00E+00
Benzo(b)fluoranthene		0.00E+00	0	0.00E+00
Benzo(k)fluoranthene		0.00E+00	0	0.00E+00
Benzo(a)Pyrene		0.00E+00	0	0.00E+00
Bis(2-ethylhexyl)phthalate		0.00E+00	0.597	6.62E-06
Chrysene		0.00E+00	0	0.00E+00
Fluoranthene		0.00E+00	0.850	9.44E-06
Naphthalene		0.00E+00	0	0.00E+00
Phenanthrene		0.00E+00	0	0.00E+00
Pyrene		0.00E+00	0	0.00E+00
Total PAHs		0.00E+00		9.44E-06
PESTICIDES				
gamma-BHC (Lindane)		0.00E+00	0	0.00E+00
4,4'-DDE		0.00E+00	0	0.00E+00
4,4'-DDD		0.00E+00	0	0.00E+00
4,4'-DDT		0.00E+00	0	0.00E+00
PCBs				
Total PCBs		0.00E+00	0	0.00E+00
OTHER				
Total Chlorine	0	0.00E+00		0.00E+00
OCDD		0.00E+00	0.0000450	5.00E-10
OCDF		0.00E+00	0.000163	1.81E-09
SO2		0.00E+00		
NO2		0.00E+00		
CO		0.00E+00		
VOC		0.00E+00	0.0762	8.46E-07
SVOC(.C-16)		0.00E+00		
SVOC(C-7 through C-16)		0.00E+00		

Appendix B: Rotary Kiln Mass Balance

Process Stream	Scrubbed Gas to Atmosphere		LWA measured	
Stream Number	14		15	
Units	LBS		LBS	
Total Mass	3,634		3,084	
Percent Moisture			0.00%	
Dry Mass Solids	1.4		3,084	
Mass Water	3,633		0	
Source of Mass				
Source of Moisture Content				
Source of Chemical Info				
Other notes	hr			
	Conc	Mass	Conc ¹	Mass
	lb/hr	lb	mg/kg	lb
METALS				
Aluminum	3.06E-05	2.94E-03	5,540	1.71E+01
Arsenic	1.31E-07	1.26E-05	9.30	2.87E-02
Barium	9.11E-09	8.77E-07	38.5	1.19E-01
Cadmium	8.88E-06	8.55E-04	0.00	0.00E+00
Chromium	3.53E-05	3.40E-03	11.2	3.45E-02
Copper	1.16E-05	1.12E-03	75.8	2.34E-01
Iron	4.69E-05	4.51E-03	11,200	3.45E+01
Lead	1.44E-04	1.39E-02	9.00	2.78E-02
Magnesium	1.96E-05	1.89E-03	1,360	4.19E+00
Manganese	2.48E-05	2.39E-03	70.6	2.18E-01
Mercury	1.71E-05	1.65E-03	0.07	2.27E-04
Nickel	5.92E-08	5.70E-06	28.8	8.88E-02
Potassium	2.00E-04	1.92E-02	627	1.93E+00
Selenium	8.41E-07	8.09E-05	0.00	0.00E+00
Silver	2.31E-07	2.22E-05	0.05	1.54E-04
Zinc	2.40E-05	2.31E-03	21.4	6.60E-02
Total Metals		5.43E-02		5.86E+01
PAHs				
Anthracene	0.00E+00	0.00E+00	0.0	0.00E+00
Benzo(a)anthracene	0.00E+00	0.00E+00	0.0	0.00E+00
Benzo(b)fluoranthene	0.00E+00	0.00E+00	0.0	0.00E+00
Benzo(k)fluoranthene	0.00E+00	0.00E+00	0.0	0.00E+00
Benzo(a)Pyrene	0.00E+00	0.00E+00	0.0	0.00E+00
Bis(2-ethylhexyl)phthalate	9.48E-06	9.12E-04	0.0	0.00E+00
Chrysene	0.00E+00	0.00E+00	0.0	0.00E+00
Fluoranthene	1.54E-07	1.48E-05	0.0	0.00E+00
Naphthalene	4.28E-07	4.12E-05	0.0	0.00E+00
Phenanthrene	1.39E-07	1.33E-05	0.0	0.00E+00
Pyrene	2.25E-07	2.16E-05	0.0	0.00E+00
Total PAHs		9.09E-05		0.00E+00
PESTICIDES				
gamma-BHC (Lindane)			0.0	0.00E+00
4,4'-DDE			0.0	0.00E+00
4,4'-DDD			0.0	0.00E+00
4,4'-DDT			0.0	0.00E+00
PCBs				
Total PCBs	5.23E-08	5.04E-06	0	0.00E+00
OTHER				
Total Chlorine	0.00E+00	0.00E+00	500	1.54E+00
OCDD			0.000024	7.40E-08
OCDF			0.0000039	1.20E-08
SO2	9.33E-04	8.98E-02		
NO2	1.99E-01	1.91E+01		
CO	2.07E-02	1.99E+00		
VOC	2.99E-03	2.88E-01		
SVOC(C-16)	1.63E-04	1.57E-02		
SVOC(C-7 through C-16)	3.96E-04	3.81E-02		

Appendix B: Rotary Kiln Mass Balance

Process Stream Stream Number	Dryer Stage				Mass Unaccounted for
	Mass In	Mass Out			
Units		Offgas	Offgas Particulates	Dried Filter Cake	
Total Mass	6,504	3598	409	2,497	0
Percent Moisture					
Dry Mass Solids	2,797	2	409	2,386	0
Mass Water	3,707	3597	0	111	0
Source of Mass					
Source of Moisture Content					
Source of Chemical Info					
Other notes					
	LBS	PCT	PCT	PCT	PCT
METALS					
Aluminum	4.45E+01	0.00	14.61	85.39	0.00
Arsenic	5.09E-02	0.00	14.61	85.39	0.00
Barium	3.44E-01	0.00	14.61	85.39	0.00
Cadmium	8.95E-03	0.00	14.61	85.39	0.00
Chromium	5.03E-01	0.00	14.61	85.39	0.00
Copper	4.98E-01	0.00	14.61	85.39	0.00
Iron	1.14E+02	0.00	14.61	85.39	0.00
Lead	5.17E-01	0.00	14.61	85.39	0.00
Magnesium	2.58E+01	0.00	14.61	85.39	0.00
Manganese	1.95E+00	0.00	14.61	85.39	0.00
Mercury	1.06E-02	6.03	14.61	79.36	0.00
Nickel	1.21E-01	0.00	14.61	85.39	0.00
Potassium	8.42E+00	0.00	14.61	85.39	0.00
Selenium	1.90E-03	0.00	14.61	85.39	0.00
Silver	1.15E-02	0.00	14.61	85.39	0.00
Zinc	8.39E-01	0.00	14.61	85.39	0.00
Total Metals	1.97E+02	0.00	14.68	85.32	0.00
PAHs					
Anthracene	1.03E-04				
Benzo(a)anthracene	1.82E-04				
Benzo(b)fluoranthene	2.38E-04				
Benzo(k)fluoranthene	1.10E-03				
Benzo(a)Pyrene	2.74E-04	0.00	14.61	85.39	0.00
Bis(2-ethylhexyl)phthalate	9.09E-04				
Chrysene	3.78E-04				
Fluoranthene	5.73E-04	0.00	14.61	85.39	0.00
Naphthalene	4.03E-04	0.00	14.61	85.39	0.00
Phenanthrene	1.37E-04				
Pyrene	4.20E-04				
Total PAHs	3.81E-03				
PESTICIDES					
gamma-BHC (Lindane)	6.15E-07				
4,4'-DDE	2.74E-06				
4,4'-DDD	2.60E-06				
4,4'-DDT	2.96E-06				
PCBs					
Total PCBs	4.03E-04	0.00	14.61	85.39	0.00
OTHER					
Total Chlorine	0.00E+00				
OCDD	1.50E-05	0.00	14.61	85.39	0.00
OCDF	4.33E-06	0.00	14.61	85.39	0.00
SO2	0.00E+00				
NO2	0.00E+00				
CO	0.00E+00				
VOC	0.00E+00				
SVOC(C-16)	0.00E+00				
SVOC(C-7 through C-16)	0.00E+00				

Appendix B: Rotary Kiln Mass Balance

Process Stream	Extruder Stage			Mass In
	Mass In	Mass Out	Mass Unaccounted for	
Stream Number				
Units				Extrudite Pellets
Total Mass	4,119	4,119	0	4,119
Percent Moisture				
Dry Mass Solids	3,451	3,451	0	3,451
Mass Water	668	668	0	668
Source of Mass				
Source of Moisture Content				
Source of Chemical Info				
Other notes				
	LBS	LBS	PCT	LBS
METALS				
Aluminum	4.56E+01	4.24E+01	6.8	4.24E+01
Arsenic	5.11E-02	3.73E-02	27.1	3.73E-02
Barium	4.34E-01	4.42E-01	-1.7	4.42E-01
Cadmium	7.64E-03	4.97E-03	35.0	4.97E-03
Chromium	4.38E-01	4.07E-01	6.96	4.07E-01
Copper	4.68E-01	4.28E-01	8.65	4.28E-01
Iron	1.23E+02	9.94E+01	19.3	9.94E+01
Lead	4.66E-01	3.90E-01	16.2	3.90E-01
Magnesium	2.47E+01	2.26E+01	8.7	2.26E+01
Manganese	2.09E+00	1.94E+00	7.3	1.94E+00
Mercury	8.57E-03	8.08E-03	5.72	8.08E-03
Nickel	1.36E-01	1.59E-01	-16.6	1.59E-01
Potassium	1.35E+01	1.44E+01	-6.8	1.44E+01
Selenium	1.62E-03	1.73E-03	-6.3	1.73E-03
Silver	9.79E-03	1.17E-02	-19.8	1.17E-02
Zinc	7.75E-01	7.25E-01	6.5	7.25E-01
Total Metals	2.12E+02	1.83E+02	13.4	1.83E+02
PAHs				
Anthracene	8.84E-05	6.49E-04	-634.3	6.49E-04
Benzo(a)anthracene	1.55E-04	1.83E-03	-1078.3	1.83E-03
Benzo(b)fluoranthene	2.03E-04	2.55E-03	-1154.7	2.55E-03
Benzo(k)fluoranthene	9.41E-04	1.22E-03	-29.5	1.22E-03
Benzo(a)Pyrene	2.34E-04	1.81E-03	-674	1.81E-03
Bis(2-ethylhexyl)phthalate	7.76E-04	2.36E-02	-2945.8	2.36E-02
Chrysene	3.22E-04	2.19E-03	-579.7	2.19E-03
Fluoranthene	4.90E-04	3.13E-03	-540	3.13E-03
Naphthalene	3.44E-04	1.43E-03	-316	1.43E-03
Phenanthrene	1.17E-04	8.11E-04	-593.1	8.11E-04
Pyrene	3.58E-04	3.03E-03	-745.9	3.03E-03
Total PAHs	3.25E-03	1.87E-02		1.87E-02
PESTICIDES				
gamma-BHC (Lindane)	5.25E-07	0.00E+00	100.0	0.00E+00
4,4'-DDE	2.34E-06	0.00E+00	100.0	0.00E+00
4,4'-DDD	2.22E-06	0.00E+00	100.0	0.00E+00
4,4'-DDT	2.53E-06	0.00E+00	100.0	0.00E+00
PCBs				
Total PCBs	3.44E-04	8.97E-04	-161	8.97E-04
OTHER				
Total Chlorine	5.32E-01	1.10E+01	-1975	1.10E+01
OCDD	1.28E-05	1.07E-05	16.3	1.07E-05
OCDF	3.70E-06	3.05E-06	17	3.05E-06
SO2	0.00E+00	0.00E+00		0.00E+00
NO2	0.00E+00	0.00E+00		0.00E+00
CO	0.00E+00	0.00E+00		0.00E+00
VOC	0.00E+00	0.00E+00		0.00E+00
SVOC(.C-16)	0.00E+00	0.00E+00		0.00E+00
SVOC(C-7 through C-16)	0.00E+00	0.00E+00		0.00E+00

Appendix B: Rotary Kiln Mass Balance

Process Stream	Kiln Stage		Offgas Scrubber Stage		
	Mass Out	Mass	Mass In	Mass Out ¹	Mass
Stream Number	Lesser (TCLP or Residual)	Unaccounted for			Unaccounted for
Units					
Total Mass	4,119	0	4,391	4,391	0
Percent Moisture					
Dry Mass Solids	3,451	0	367	367	0
Mass Water	668	0	4,024	4,024	0
Source of Mass					
Source of Moisture Content					
Source of Chemical Info					
Other notes					
	LBS	PCT	LBS	LBS	PCT
METALS					
Aluminum	1.75E+01	58.8	2.07E-01	5.22E-03	97.48
Arsenic	4.25E-03	88.6	3.09E-03	1.26E-05	99.59
Barium	1.56E-02	96.5	2.11E-03	8.77E-07	99.96
Cadmium	5.73E-03	-15.3	4.24E-03	8.55E-04	79.86
Chromium	1.01E-02	97.5	6.98E-03	3.53E-03	49.33
Copper	1.90E-02	95.6	7.80E-03	1.50E-03	80.75
Iron	2.89E+00	97.1	2.70E-01	5.50E-03	97.97
Lead	1.86E-01	52.2	1.36E-01	1.39E-02	89.73
Magnesium	1.02E+00	95.5	1.90E-01	7.72E-02	59.39
Manganese	1.26E-01	93.5	9.49E-03	2.53E-03	73.35
Mercury	4.38E-03	45.8	4.29E-03	1.65E-03	61.65
Nickel	8.04E-03	94.9	3.65E-03	5.70E-06	99.84
Potassium	6.66E-01	95.4	1.89E-01	6.42E-02	65.96
Selenium	6.98E-04	59.5	4.47E-04	1.19E-04	73.27
Silver	5.57E-04	95.3	2.02E-04	2.22E-05	89.00
Zinc	6.02E-02	91.7	3.02E-02	2.50E-03	91.73
Total Metals	6.11E+01	66.7	1.05E+00	1.79E-01	82.97
PAHs					
Anthracene	1.27E-05	98.0	1.27E-05	0.00E+00	100.00
Benzo(a)anthracene	0.00E+00	100.0	0.00E+00	0.00E+00	#DIV/0!
Benzo(b)fluoranthene	0.00E+00	100.0	0.00E+00	0.00E+00	#DIV/0!
Benzo(k)fluoranthene	0.00E+00	100.0	0.00E+00	0.00E+00	#DIV/0!
Benzo(a)Pyrene	0.00E+00	100.0	0.00E+00	0.00E+00	#DIV/0!
Bis(2-ethylhexyl)phthalate	6.10E-05	99.7	5.44E-05	9.12E-04	-1577.88
Chrysene	7.13E-05	96.7	7.13E-05	0.00E+00	100.00
Fluoranthene	2.45E-04	92.2	2.36E-04	1.48E-05	93.73
Naphthalene	2.17E-03	-51.9	2.17E-03	4.12E-05	98.11
Phenanthrene	4.47E-04	44.9	4.47E-04	1.33E-05	97.02
Pyrene	1.01E-04	96.7	1.01E-04	2.16E-05	78.62
Total PAHs	3.05E-03		3.04E-03	9.09E-05	
PESTICIDES					
gamma-BHC (Lindane)	0.00E+00		0.00E+00	0.00E+00	
4,4'-DDE	0.00E+00		0.00E+00	0.00E+00	
4,4'-DDD	0.00E+00		0.00E+00	0.00E+00	
4,4'-DDT	0.00E+00		0.00E+00	0.00E+00	
PCBs					
Total PCBs	3.89E-04	56.6	3.89E-04	5.04E-06	98.71
OTHER					
Total Chlorine	1.66E+00	85.0	1.14E-01	0.00E+00	100.00
OCDD	7.45E-08	99.3	0.00E+00	0.00E+00	
OCDF	1.38E-08	99.5	0.00E+00	0.00E+00	
SO2	2.02E+01		2.02E+01	8.98E-02	99.56
NO2	1.73E+01		1.73E+01	1.91E+01	-10.56
CO	2.41E+01		2.41E+01	1.99E+00	91.72
VOC	1.35E+00		1.35E+00	2.88E-01	78.64
SVOC(C-16)	4.22E-01		4.22E-01	1.57E-02	96.29
SVOC(C-7 through C-16)	1.78E-01		1.78E-01	3.81E-02	78.59

Appendix B: Rotary Kiln Mass Balance

Process Stream	Overall Efficiency		
	Based on Total Contaminant Mass		
Stream Number	Mass	Mass	Efficiency
Units	Inputs	Ouputs	
Total Mass			
Percent Moisture			
Dry Mass Solids			
Mass Water			
Source of Mass			
Source of Moisture Content			
Source of Chemical Info			
Other notes			
	LBS	LBS	PCT
METALS			
Aluminum	5.21E+01	2.38E+01	54.3
Arsenic	5.86E-02	3.70E-02	36.9
Barium	4.85E-01	1.69E-01	65.1
Cadmium	8.95E-03	3.65E-03	59.2
Chromium	5.11E-01	1.15E-01	77.6
Copper	5.41E-01	3.13E-01	42.1
Iron	1.40E+02	5.14E+01	63.2
Lead	5.41E-01	1.68E-01	69.0
Magnesium	2.86E+01	8.80E+00	69.2
Manganese	2.38E+00	6.14E-01	74.1
Mercury	1.08E-02	4.15E-03	61.4
Nickel	1.54E-01	1.08E-01	29.7
Potassium	1.47E+01	3.44E+00	76.7
Selenium	1.90E-03	6.49E-04	65.9
Silver	1.15E-02	2.05E-03	82.1
Zinc	8.98E-01	2.00E-01	77.7
Total Metals	2.40E+02	8.92E+01	62.8
PAHs			
Anthracene	1.03E-04	1.51E-05	85.4
Benzo(a)anthracene	1.82E-04	2.66E-05	85.4
Benzo(b)fluoranthene	2.38E-04	3.47E-05	85.4
Benzo(k)fluoranthene	1.10E-03	1.61E-04	85.4
Benzo(a)Pyrene	2.74E-04	4.01E-05	85.4
Bis(2-ethylhexyl)phthalate	9.09E-04	1.05E-03	-15.7
Chrysene	3.78E-04	5.52E-05	85.4
Fluoranthene	5.73E-04	1.08E-04	81.2
Naphthalene	4.03E-04	1.00E-04	75.2
Phenanthrene	1.37E-04	3.34E-05	75.7
Pyrene	4.20E-04	8.29E-05	80.2
Total PAHs	3.81E-03	6.57E-04	
PESTICIDES	0.00E+00	0.00E+00	
gamma-BHC (Lindane)	6.15E-07	8.99E-08	85.4
4,4'-DDE	2.74E-06	4.01E-07	85.4
4,4'-DDD	2.60E-06	3.80E-07	85.4
4,4'-DDT	2.96E-06	4.33E-07	85.4
PCBs	0.00E+00	0.00E+00	
Total PCBs	4.03E-04	6.39E-05	84.1
OTHER	0.00E+00	0.00E+00	
Total Chlorine	5.32E-01	1.54E+00	-189.7
OCDD	1.50E-05	2.26E-06	84.9
OCDF	4.33E-06	6.47E-07	85.1
SO2	0.00E+00	2.01E+00	
NO2	0.00E+00	2.30E+01	
CO	0.00E+00	2.99E+01	
VOC	0.00E+00	1.86E+01	
SVOC(C-16)	0.00E+00	1.57E-02	
SVOC(C-7 through C-16)	0.00E+00	3.81E-02	

Appendix B: Rotary Kiln Mass Balance

Process Stream	Overall Efficiency		
	Higher Efficiency Total Mass or TCLP Mass		Efficiency
Stream Number	Mass	Mass	
Units	Inputs	Outputs (TCLP/Residual)	
Total Mass			
Percent Moisture			
Dry Mass Solids			
Mass Water			
Source of Mass			
Source of Moisture Content			
Source of Chemical Info			
Other notes			
	LBS	LBS	PCT
METALS			
Aluminum	5.21E+01	6.72E+00	87.1
Arsenic	5.86E-02	8.62E-03	85.3
Barium	4.85E-01	6.39E-02	86.8
Cadmium	8.95E-03	3.65E-03	59.2
Chromium	5.11E-01	8.02E-02	84.3
Copper	5.41E-01	8.57E-02	84.2
Iron	1.40E+02	1.93E+01	86.2
Lead	5.41E-01	1.40E-01	74.1
Magnesium	2.86E+01	4.77E+00	83.3
Manganese	2.38E+00	4.04E-01	83.0
Mercury	1.08E-02	3.93E-03	63.5
Nickel	1.54E-01	2.21E-02	85.7
Potassium	1.47E+01	1.78E+00	87.9
Selenium	1.90E-03	6.49E-04	65.9
Silver	1.15E-02	2.05E-03	82.1
Zinc	8.98E-01	1.55E-01	82.7
Total Metals	2.40E+02		
PAHs			
Anthracene	1.03E-04	1.51E-05	85.4
Benzo(a)anthracene	1.82E-04	2.66E-05	85.4
Benzo(b)fluoranthene	2.38E-04	3.47E-05	85.4
Benzo(k)fluoranthene	1.10E-03	1.61E-04	85.4
Benzo(a)Pyrene	2.74E-04	4.01E-05	85.4
Bis(2-ethylhexyl)phthalate	9.09E-04	1.05E-03	-15.7
Chrysene	3.78E-04	5.52E-05	85.4
Fluoranthene	5.73E-04	1.08E-04	81.2
Naphthalene	4.03E-04	1.00E-04	75.2
Phenanthrene	1.37E-04	3.34E-05	75.7
Pyrene	4.20E-04	8.29E-05	80.2
Total PAHs	3.81E-03	6.57E-04	
PESTICIDES			
gamma-BHC (Lindane)	6.15E-07	8.99E-08	85.4
4,4'-DDE	2.74E-06	4.01E-07	85.4
4,4'-DDD	2.60E-06	3.80E-07	85.4
4,4'-DDT	2.96E-06	4.33E-07	85.4
PCBs			
Total PCBs	4.03E-04	6.39E-05	84.1
OTHER			
Total Chlorine	5.32E-01	1.54E+00	-189.7
OCDD	1.50E-05	2.26E-06	84.9
OCDF	4.33E-06	6.47E-07	85.1
SO2	0.00E+00	2.01E+00	
NO2	0.00E+00	2.30E+01	
CO	0.00E+00	2.99E+01	
VOC	0.00E+00	1.86E+01	
SVOC(C-16)	0.00E+00	1.57E-02	
SVOC(C-7 through C-16)	0.00E+00	3.81E-02	

Appendix B: Rotary Kiln Mass Balance

Process Stream	Decontamination Efficiency				
	Mass	Mass	LWA	Efficiency	Efficiency
Stream Number	Incoming Filter Cake	LWA ^a	Leachable Mass	Residual	Leachable
Units					
Total Mass					
Percent Moisture					
Dry Mass Solids					
Mass Water					
Source of Mass					
Source of Moisture Content					
Source of Chemical Info					
Other notes					
	LBS	LBS	LBS	PCT	PCT
METALS					
Aluminum	4.45E+01	1.71E+01		61.6	
Arsenic	5.09E-02	2.87E-02	3.08E-04	43.7	100.00
Barium	3.44E-01	1.19E-01	1.36E-02	65.5	99.97
Cadmium	8.95E-03	0.00E+00	0.00E+00	100.0	100.00
Chromium	5.03E-01	3.45E-02	0.00E+00	93.1	100.00
Copper	4.98E-01	2.34E-01	6.17E-03	53.0	99.99
Iron	1.14E+02	3.45E+01	2.42E+00	69.7	94.56
Lead	5.17E-01	2.78E-02	2.77E-04	94.6	100.00
Magnesium	2.58E+01	4.19E+00	1.59E-01	83.7	99.64
Manganese	1.95E+00	2.18E-01	7.34E-03	88.8	99.98
Mercury	1.06E-02	2.27E-04	0.00E+00	97.9	100.00
Nickel	1.21E-01	8.88E-02	2.77E-03	26.5	99.99
Potassium	8.42E+00	1.93E+00	2.77E-01	77.0	99.38
Selenium	1.90E-03	0.00E+00	9.87E-04	100.0	100.00
Silver	1.15E-02	1.54E-04	9.87E-04	98.7	100.00
Zinc	8.39E-01	6.60E-02	2.11E-02	92.1	99.95
Total Metals	1.97E+02	5.86E+01	2.91E+00		93.46
PAHs					
Anthracene	1.03E-04	0.00E+00	0.00E+00	100.0	100.00
Benzo(a)anthracene	1.82E-04	0.00E+00	0.00E+00	100.0	100.00
Benzo(b)fluoranthene	2.38E-04	0.00E+00	0.00E+00	100.0	100.00
Benzo(k)fluoranthene	1.10E-03	0.00E+00	0.00E+00	100.0	100.00
Benzo(a)Pyrene	2.74E-04	0.00E+00	0.00E+00	100.0	100.00
Bis(2-ethylhexyl)phthalate	9.09E-04	0.00E+00	0.00E+00	100.0	100.00
Chrysene	3.78E-04	0.00E+00	0.00E+00	100.0	100.00
Fluoranthene	5.73E-04	0.00E+00	0.00E+00	100.0	100.00
Naphthalene	4.03E-04	0.00E+00	0.00E+00	100.0	100.00
Phenanthrene	1.37E-04	0.00E+00	0.00E+00	100.0	100.00
Pyrene	4.20E-04	0.00E+00	0.00E+00	100.0	100.00
Total PAHs	3.81E-03	0.00E+00	0.00E+00		
PESTICIDES					
gamma-BHC (Lindane)	6.15E-07	0.00E+00		100.0	
4,4'-DDE	2.74E-06	0.00E+00		100.0	
4,4'-DDD	2.60E-06	0.00E+00		100.0	
4,4'-DDT	2.96E-06	0.00E+00		100.0	
PCBs					
Total PCBs	4.03E-04	0.00E+00		100.0	
OTHER					
Total Chlorine	0.00E+00	1.54E+00			
OCDD	1.50E-05	7.40E-08		99.5	
OCDF	4.33E-06	1.20E-08		99.7	
SO2	0.00E+00	0.00E+00			
NO2	0.00E+00	0.00E+00			
CO	0.00E+00	0.00E+00			
VOC	0.00E+00	0.00E+00			
SVOC(C-16)	0.00E+00	0.00E+00			
SVOC(C-7 through C-16)	0.00E+00	0.00E+00			

Appendix B: Rotary Kiln Mass Balance

Process Stream	Reduction in Contaminant Extractability			
	TCLP Filter Cake Concentration	TCLP LWA Concentration	Fraction Extractable/kg Filter Cake	Fraction Extractable/kg LWA
Stream Number				
Units				
Total Mass				
Percent Moisture				
Dry Mass Solids				
Mass Water				
Source of Mass				
Source of Moisture Content				
Source of Chemical Info				
Other notes				
	mg/L	mg/L		
METALS				
Aluminum				
Arsenic	0.18	0.005	19.77%	1.07%
Barium	0.115	0.22	1.87%	11.43%
Cadmium	0.013	0	8.12%	
Chromium	0.00315	0	0.03%	0.00%
Copper		0.1		2.64%
Iron		39.2		7.00%
Lead	0.02025	0.0045	0.22%	1.00%
Magnesium		2.58		3.79%
Manganese		0.119		3.37%
Mercury	0.000052	0	0.03%	0.00%
Nickel		0.045		3.12%
Potassium		4.49		14.32%
Selenium	0	0.016	0.00%	
Silver	0	0.016	0.00%	639.82%
Zinc		0.342		31.95%
Total Metals				
PAHs				
Anthracene	0	0	0.00%	
Benzo(a)anthracene	0	0	0.00%	
Benzo(b)fluoranthene	0	0	0.00%	
Benzo(k)fluoranthene	0	0	0.00%	
Benzo(a)Pyrene	0	0	0.00%	
Bis(2-ethylhexyl)phthalate	0	0	0.00%	
Chrysene	0	0	0.00%	
Fluoranthene	0	0	0.00%	
Naphthalene	0	0	0.00%	
Phenanthrene	0	0	0.00%	
Pyrene	0	0	0.00%	
Total PAHs				
PESTICIDES				
gamma-BHC (Lindane)				
4,4'-DDE				
4,4'-DDD				
4,4'-DDT				
PCBs				
Total PCBs				
OTHER				
Total Chlorine				
OCDD				
OCDF				
SO2				
NO2				
CO				
VOC				
SVOC(C-16)				
SVOC(C-7 through C-16)				

Appendix B: Rotary Kiln Mass Balance

Process Stream	En		
Stream Number	Offgas	Particulates	Wastewater
Units			
Total Mass	7,232	420	746
Percent Moisture			
Dry Mass Solids	3.0	420	354
Mass Water	7,229	0	392
Source of Mass			
Source of Moisture Content			
Source of Chemical Info			
Other notes			
METALS	LBS	LBS	LBS
Aluminum	2.94E-03	6.71E+00	0.0022753
Arsenic	1.26E-05	8.29E-03	0.00E+00
Barium	8.77E-07	5.03E-02	0.00E+00
Cadmium	8.55E-04	2.80E-03	0.00E+00
Chromium	3.40E-03	7.67E-02	1.38E-04
Copper	1.12E-03	7.80E-02	3.86E-04
Iron	4.51E-03	1.68E+01	9.85E-04
Lead	1.39E-02	1.26E-01	8.28E-05
Magnesium	1.89E-03	4.53E+00	7.53E-02
Manganese	2.39E-03	3.94E-01	1.42E-04
Mercury	2.29E-03	1.64E-03	4.40E-07
Nickel	5.70E-06	1.93E-02	0.00E+00
Potassium	1.92E-02	1.44E+00	4.50E-02
Selenium	8.09E-05	5.30E-04	3.84E-05
Silver	2.22E-05	1.88E-03	0.00E+00
Zinc	2.31E-03	1.32E-01	1.89E-04
Total Metals	5.26E-02	3.03E+01	1.24E-01
PAHs			
Anthracene	0.00E+00	1.51E-05	0.00E+00
Benzo(a)anthracene	0.00E+00	2.66E-05	0.00E+00
Benzo(b)fluoranthene	0.00E+00	3.47E-05	0.00E+00
Benzo(k)fluoranthene	0.00E+00	1.61E-04	0.00E+00
Benzo(a)Pyrene	0.00E+00	4.01E-05	0.00E+00
Bis(2-ethylhexyl)phthalate	9.12E-04	1.39E-04	0.00E+00
Chrysene	0.00E+00	5.52E-05	0.00E+00
Fluoranthene	1.48E-05	9.32E-05	0.00E+00
Naphthalene	4.12E-05	5.89E-05	0.00E+00
Phenanthrene	1.33E-05	2.00E-05	0.00E+00
Pyrene	2.16E-05	6.13E-05	0.00E+00
Total PAHs	9.09E-05	5.66E-04	0.00E+00
PESTICIDES			
gamma-BHC (Lindane)	0.00E+00	8.99E-08	0.00E+00
4,4'-DDE	0.00E+00	4.01E-07	0.00E+00
4,4'-DDD	0.00E+00	3.80E-07	0.00E+00
4,4'-DDT	0.00E+00	4.33E-07	0.00E+00
PCBs			
Total PCBs	5.04E-06	5.89E-05	0.00E+00
OTHER			
Total Chlorine	0.00E+00	0.00E+00	0.00E+00
OCDD	0.00E+00	2.19E-06	0.00E+00
OCDF	0.00E+00	6.35E-07	0.00E+00
SO2	2.01E+00	0.00E+00	0.00E+00
NO2	2.30E+01	0.00E+00	0.00E+00
CO	2.99E+01	0.00E+00	0.00E+00
VOC	1.86E+01	8.46E-07	0.00E+00
SVOC(C-16)	1.57E-02	0.00E+00	0.00E+00
SVOC(C-7 through C-16)	3.81E-02	0.00E+00	0.00E+00

Appendix B: Rotary Kiln Mass Balance

Process Stream	Emissions (Residuals)			
Stream Number	Percent of Incoming Contaminant Mass			
Units	Offgas	Particulates	Wastewater	Total
Total Mass				
Percent Moisture				
Dry Mass Solids	0.11%	15%	13%	28%
Mass Water	195%	0%	11%	206%
Source of Mass				
Source of Moisture Content				
Source of Chemical Info				
Other notes				
METALS	PCT	PCT	PCT	PCT
Aluminum	0.01	15.09	0.01	15.11
Arsenic	0.02	16.30	0.00	16.32
Barium	0.00	14.62	0.00	14.62
Cadmium	9.55	31.23	0.00	40.78
Chromium	0.67	15.23	0.03	15.93
Copper	0.22	15.68	0.08	15.98
Iron	0.00	14.80	0.00	14.80
Lead	2.68	24.38	0.02	27.07
Magnesium	0.01	17.56	0.29	17.86
Manganese	0.12	20.25	0.01	20.38
Mercury	21.51	15.45	0.00	36.96
Nickel	0.00	15.96	0.00	15.96
Potassium	0.23	17.08	0.53	17.84
Selenium	4.26	27.86	2.02	34.14
Silver	0.19	16.37	0.00	16.56
Zinc	0.28	15.68	0.02	15.98
Total Metals	0.027	15.41	0.063	15.50
PAHs				
Anthracene	0.00	14.61	0.00	14.61
Benzo(a)anthracene	0.00	14.61	0.00	14.61
Benzo(b)fluoranthene	0.00	14.61	0.00	14.61
Benzo(k)fluoranthene	0.00	14.61	0.00	14.61
Benzo(a)Pyrene	0.00	14.61	0.00	14.61
Bis(2-ethylhexyl)phthalate	100.37	15.34	0.00	115.71
Chrysene	0.00	14.61	0.00	14.61
Fluoranthene	2.58	16.26	0.00	18.84
Naphthalene	10.23	14.61	0.00	24.84
Phenanthrene	9.73	14.61	0.00	24.34
Pyrene	5.15	14.61	0.00	19.76
Total PAHs	2.39	14.86	0.00	17.25
PESTICIDES				
gamma-BHC (Lindane)	0.00	14.61	0.00	14.61
4,4'-DDE	0.00	14.61	0.00	14.61
4,4'-DDD	0.00	14.61	0.00	14.61
4,4'-DDT	0.00	14.61	0.00	14.61
PCBs				
Total PCBs	1.25	14.61	0.00000	15.86
OTHER				
Total Chlorine		#DIV/0!		
OCDD	0.00	14.62	0.00	14.62
OCDF	0.00	14.66	0.00	14.66
SO2				
NO2				
CO				
VOC				
SVOC(C-16)				
SVOC(C-7 through C-16)				

Appendix C: Cement-Lock® Mass Balance

The enclosed tables support mass balance calculations reflected in the following:

- Chapter 2
 - Tables 7-9
 - Figure 6
- Chapter 3
 - Tables 18 and 19
 - Figures 19-24
- Chapter 6
 - Table 33
 - Figure 44

Appendix C: Cement-Lock Mass Balance

Process Stream	Raw Feed to Ecomelt® Generator		Modifier to Ecomelt® Generator		Quenched Ecomelt® from Granulator		Quenched Ecomelt® from Granulator SPLP Analysis		
Stream Number	1		A		3		3		
Units	lb		lb		lb		lb		
Total Mass	56,200		15,720		46,500		46,500		
Percent Moisture	27.50%		0.0%		0.0%		0.0%		
Dry Weight Solids	40,745		15,720		46,500		46,500		
Water	15,455		0.00		0.00		0.00		
Source of Mass	Mensinger 2008a, App B, pp 27 & 32		Mensinger 2008a, App B, pp 27 & 32		Mensinger 2008a, App B, pp 27 & 32		Mensinger 2008a, App B, pp 27 & 32		
Source of Moisture Content	Mensinger 2008a, p 29		Assumed		Calculated from Solid mass balance.		Assumed		
Source of Chemical Info	Mensinger 2008a, App G, Table G-1		Assumed		Mensinger 2008a, App G, Table G-2		Mensinger 2008a, Table 11, p 40		
Other notes									
	Conc	Mass	Conc	Mass	Conc	Mass	Leachate	Conc	Mass
	mg/kg	lb	mg/kg	lb	mg/kg	lb	mg/L	mg/kg	lb
METALS									
Arsenic	1.53E+01	6.23E-01			6.20E+00	2.88E-01	0.00E+00	0.00E+00	0.00E+00
Barium	1.73E+02	7.05E+00			1.60E+02	7.45E+00	0.00E+00	0.00E+00	0.00E+00
Cadmium	6.83E+00	2.78E-01			3.68E-01	1.71E-02	0.00E+00	0.00E+00	0.00E+00
Chromium	1.97E+02	8.01E+00			1.07E+02	4.98E+00	0.00E+00	0.00E+00	0.00E+00
Cobalt	1.13E+01	4.62E-01			7.21E+00	3.35E-01	0.00E+00	0.00E+00	0.00E+00
Copper	2.44E+02	9.96E+00			9.56E+01	4.45E+00	0.00E+00	0.00E+00	0.00E+00
Lead	3.67E+02	1.50E+01			2.10E+01	9.77E-01	1.80E-02	3.60E-01	1.67E-02
Manganese	4.16E+02	1.70E+01			3.51E+02	1.63E+01	4.27E-02	8.53E-01	3.97E-02
Mercury	4.79E+00	1.95E-01			1.54E-02	7.17E-04	1.63E-04	3.27E-03	1.52E-04
Nickel	4.93E+01	2.01E+00			3.42E+01	1.59E+00	2.77E-02	5.53E-01	2.57E-02
Selenium	1.35E+00	5.48E-02			0.00E+00	0.00E+00	0.00E+00	0.00E+00	0.00E+00
Silver	5.76E+00	2.35E-01			5.24E-01	2.44E-02	0.00E+00	0.00E+00	0.00E+00
Zinc	6.42E+02	2.62E+01			7.10E+01	3.30E+00	1.00E-01	2.00E+00	9.30E-02
TOTAL Metals	2.13E+03	8.70E+01			8.54E+02	3.97E+01	1.88E-01	3.77E+00	1.75E-01
SVOCs									
Acenaphthene	1.20E-01	4.90E-03			0.00E+00	0.00E+00			
Acenaphthylene	2.81E-01	1.14E-02			3.06E-04	1.42E-05			
Anthracene	3.73E-01	1.52E-02			0.00E+00	0.00E+00			
Benzo(a)anthracene	1.47E+00	6.00E-02			0.00E+00	0.00E+00	0.00E+00	0.00E+00	0.00E+00
Benzo(a)Pyrene	1.43E+00	5.83E-02			0.00E+00	0.00E+00	0.00E+00	0.00E+00	0.00E+00
Benzo(b)fluoranthene	1.62E+00	6.59E-02			0.00E+00	0.00E+00	0.00E+00	0.00E+00	0.00E+00
Benzo(g,h,i)perylene	8.15E-01	3.32E-02			0.00E+00	0.00E+00			
Benzo(k)fluoranthene	8.85E-01	3.61E-02			0.00E+00	0.00E+00	0.00E+00	0.00E+00	0.00E+00
Bis(2-ethylhexyl)phthalate	2.71E+01	1.10E+00			0.00E+00	0.00E+00	0.00E+00	0.00E+00	0.00E+00
Chrysene	1.44E+00	5.85E-02			0.00E+00	0.00E+00	0.00E+00	0.00E+00	0.00E+00
Dibenzo(a,h)anthracene	1.07E-01	4.36E-03			0.00E+00	0.00E+00			
Di-n-octylphthalate	8.33E-01	3.39E-02			0.00E+00	0.00E+00			
Fluoranthene	2.77E+00	1.13E-01			0.00E+00	0.00E+00			
Fluorene	1.75E-01	7.12E-03			0.00E+00	0.00E+00			
Indeno(1,2,3-c,d)pyrene	6.75E-01	2.75E-02			0.00E+00	0.00E+00	0.00E+00	0.00E+00	0.00E+00
Naphthalene	1.63E-01	6.64E-03			0.00E+00	0.00E+00			
Phenanthrene	1.05E+00	4.29E-02			0.00E+00	0.00E+00			
Pyrene	2.56E+00	1.04E-01			0.00E+00	0.00E+00			
TOTAL PAHs (16 compound)	1.59E+01	6.49E-01			3.06E-04	1.42E-05	0.00E+00	0.00E+00	0.00E+00
PESTICIDES									
4,4'-DDD	2.87E-02	1.17E-03			0.00E+00	0.00E+00	0.00E+00	0.00E+00	0.00E+00
4,4'-DDE	4.12E-02	1.68E-03			0.00E+00	0.00E+00	0.00E+00	0.00E+00	0.00E+00
4,4'-DDT	1.91E-01	7.78E-03			0.00E+00	0.00E+00	0.00E+00	0.00E+00	0.00E+00
TOTAL DDT-DDE-DDD	2.61E-01	1.06E-02			0.00E+00	0.00E+00	0.00E+00	0.00E+00	0.00E+00
PCBs									
Total PCBs (209 Congeners)	2.76E+00	1.12E-01			2.11E-04	9.82E-06			
DIOXINS/FURANS									
2,3,7,8-TCDD	7.59E-04	3.09E-05			0.00E+00	0.00E+00			
1,2,3,7,8-PeCDD	2.31E-05	9.41E-07			0.00E+00	0.00E+00			
2,3,4,7,8-PeCDF	8.26E-05	3.37E-06			1.35E-06	6.28E-08			
Total Dioxins/Furans (22 Congeners)	2.07E-02	8.44E-04			1.66E-05	7.71E-07			

Appendix C: Cement-Lock Mass Balance

Process Stream	Quenched Ecomelt® from Granulator TCLP Analysis			Quencher Water		Flue Gas to Baghouse		Baghouse Solids	
Stream Number	3			10		15		13	
Units	lb			lb		lb		lb	
Total Mass	46,500			0		25,420			
Percent Moisture	0.0%			100.0%					
Dry Weight Solids	46,500			0		9,965			
Water	0.00			0.00		15,455			
Source of Mass	Mensinger 2008a, App B, pp 27 & 32			No info		No info		No info	
Source of Moisture Content	Assumed			Assumed		No info		No info	
Source of Chemical Info	Mensinger 2008a, Table 11, p 40			Mensinger 2008a, App D, p 32		No info		No info	
Other notes									
	Leachate	Conc	Mass	Conc	Mass	Mass	Mass	Mass	Mass
	mg/L	mg/kg	lb	mg/L	lb	lb/hr	lb	lb/hr	lb
METALS									
Arsenic	0.00E+00	0.00E+00	0.00E+00	2.84E-07	0.00E+00				
Barium	6.67E-01	1.33E+01	6.20E-01	2.23E-07	0.00E+00				
Cadmium	3.62E-03	7.23E-02	3.36E-03	1.62E-07	0.00E+00				
Chromium	8.33E-03	1.67E-01	7.75E-03	1.51E-06	0.00E+00				
Cobalt	0.00E+00	0.00E+00	0.00E+00	3.56E-08	0.00E+00				
Copper	4.33E-02	8.67E-01	4.03E-02	7.16E-07	0.00E+00				
Lead	0.00E+00	0.00E+00	0.00E+00	4.49E-06	0.00E+00				
Manganese	7.02E-02	1.40E+00	6.53E-02	2.75E-06	0.00E+00				
Mercury	0.00E+00	0.00E+00	0.00E+00	1.40E-08	0.00E+00				
Nickel	4.00E-02	8.00E-01	3.72E-02	1.25E-06	0.00E+00				
Selenium	0.00E+00	0.00E+00	0.00E+00	1.88E-08	0.00E+00				
Silver	0.00E+00	0.00E+00	0.00E+00	2.79E-08	0.00E+00				
Zinc	2.82E-01	5.63E+00	2.62E-01	2.07E-05	0.00E+00				
TOTAL Metals	1.11E+00	2.23E+01	1.04E+00	3.22E-05	0.00E+00				
SVOCs									
Acenaphthene	0.00E+00	0.00E+00	0.00E+00	0.00E+00	0.00E+00				
Acenaphthylene	0.00E+00	0.00E+00	0.00E+00	0.00E+00	0.00E+00				
Anthracene	0.00E+00	0.00E+00	0.00E+00	0.00E+00	0.00E+00				
Benzo(a)anthracene	0.00E+00	0.00E+00	0.00E+00	0.00E+00	0.00E+00				
Benzo(a)Pyrene	0.00E+00	0.00E+00	0.00E+00	0.00E+00	0.00E+00				
Benzo(b)fluoranthene	0.00E+00	0.00E+00	0.00E+00	0.00E+00	0.00E+00				
Benzo(g,h,i)perylene	0.00E+00	0.00E+00	0.00E+00	0.00E+00	0.00E+00				
Benzo(k)fluoranthene	0.00E+00	0.00E+00	0.00E+00	0.00E+00	0.00E+00				
Bis(2-ethylhexyl)phthalate	0.00E+00	0.00E+00	0.00E+00	0.00E+00	0.00E+00				
Chrysene	0.00E+00	0.00E+00	0.00E+00	0.00E+00	0.00E+00				
Dibenzo(a,h)anthracene	0.00E+00	0.00E+00	0.00E+00	0.00E+00	0.00E+00				
Di-n-octylphthalate	0.00E+00	0.00E+00	0.00E+00	0.00E+00	0.00E+00				
Fluoranthene	0.00E+00	0.00E+00	0.00E+00	0.00E+00	0.00E+00				
Fluorene	0.00E+00	0.00E+00	0.00E+00	0.00E+00	0.00E+00				
Indeno(1,2,3-c,d)pyrene	0.00E+00	0.00E+00	0.00E+00	0.00E+00	0.00E+00				
Naphthalene	0.00E+00	0.00E+00	0.00E+00	0.00E+00	0.00E+00				
Phenanthrene	0.00E+00	0.00E+00	0.00E+00	0.00E+00	0.00E+00				
Pyrene	0.00E+00	0.00E+00	0.00E+00	0.00E+00	0.00E+00				
TOTAL PAHs (16 compounds)	0.00E+00	0.00E+00	0.00E+00	0.00E+00	0.00E+00				
PESTICIDES									
4,4'-DDD	0.00E+00	0.00E+00	0.00E+00	0.00E+00	0.00E+00				
4,4'-DDE	0.00E+00	0.00E+00	0.00E+00	0.00E+00	0.00E+00				
4,4'-DDT	0.00E+00	0.00E+00	0.00E+00	0.00E+00	0.00E+00				
TOTAL DDT-DDE-DDD	0.00E+00	0.00E+00	0.00E+00	0.00E+00	0.00E+00				
PCBs									
Total PCBs (209 Congeners)				3.20E-05	0.00E+00				
DIOXINS/FURANS									
2,3,7,8-TCDD				3.05E-09	0.00E+00				
1,2,3,7,8-PeCDD				0.00E+00	0.00E+00				
2,3,4,7,8-PeCDF				1.58E-09	0.00E+00				
Total Dioxins/Furans (22 Congeners)				1.97E-07	0.00E+00				

Appendix C: Cement-Lock Mass Balance

Process Stream	Flue Gas from Baghouse to Carbon Column		Clean Exhaust Gas from Carbon Column		Vapor from Granulator	
Stream Number	16		14		8	
Units	lb		lb		lb	
Total Mass	25,420		25,420		15,810	
Percent Moisture					100.0%	
Dry Weight Solids	9,965		9,965		0	
Water	15,455		15,455		15,810	
Source of Mass	NA		NA		Mensinger 2008a, p 53	
Source of Moisture Content	NA		NA		Assumed	
Source of Chemical Info	Mensinger 2008a, App F PDF pp 177-301		EPDF pp 84-159 &		Mensinger 2008a, Appx D	
Other notes	Duration (h):	37.50			Avg rate (lb/hr):	421.6
	Mass	Mass	Mass	Mass	Conc	Mass
	lb/hr	lb	lb/hr	lb	mg/L	lb
METALS						
Arsenic	5.25E-05	1.97E-03	2.94E-05	1.10E-03	0.00E+00	0.00E+00
Barium	6.76E-05	2.53E-03	7.39E-05	2.77E-03	0.00E+00	0.00E+00
Cadmium	7.98E-05	2.99E-03	2.56E-05	9.58E-04	0.00E+00	0.00E+00
Chromium	2.18E-04	8.19E-03	2.78E-04	1.04E-02	0.00E+00	0.00E+00
Cobalt	1.11E-05	4.15E-04	7.55E-06	2.83E-04	0.00E+00	0.00E+00
Copper	1.17E-04	4.38E-03	1.89E-04	7.08E-03	0.00E+00	0.00E+00
Lead	3.37E-04	1.26E-02	3.12E-04	1.17E-02	0.00E+00	0.00E+00
Manganese	2.57E-03	9.66E-02	9.63E-04	3.61E-02	0.00E+00	0.00E+00
Mercury	2.07E-03	7.77E-02	1.58E-04	5.94E-03	1.43E-04	2.25E-06
Nickel	1.79E-04	6.73E-03	1.06E-04	3.96E-03	0.00E+00	0.00E+00
Selenium	5.52E-05	2.07E-03	1.05E-05	3.92E-04	0.00E+00	0.00E+00
Silver	1.54E-05	5.76E-04	2.30E-05	8.64E-04	0.00E+00	0.00E+00
Zinc	1.09E-03	4.08E-02	6.27E-04	2.35E-02	0.00E+00	0.00E+00
TOTAL Metals	6.87E-03	2.58E-01	2.80E-03	1.05E-01	1.43E-04	2.25E-06
SVOCs						
Acenaphthene	2.55E-07	9.56E-06	0.00E+00	0.00E+00	0.00E+00	0.00E+00
Acenaphthylene	0.00E+00	0.00E+00	0.00E+00	0.00E+00	0.00E+00	0.00E+00
Anthracene	9.58E-08	3.59E-06	0.00E+00	0.00E+00	0.00E+00	0.00E+00
Benzo(a)anthracene	9.93E-07	3.72E-05	2.93E-07	1.10E-05	0.00E+00	0.00E+00
Benzo(a)Pyrene	3.29E-07	1.24E-05	2.51E-07	9.42E-06	0.00E+00	0.00E+00
Benzo(b)fluoranthene	5.95E-07	2.23E-05	0.00E+00	0.00E+00	0.00E+00	0.00E+00
Benzo(g,h,i)perylene	3.75E-07	1.41E-05	0.00E+00	0.00E+00	0.00E+00	0.00E+00
Benzo(k)fluoranthene	0.00E+00	0.00E+00	0.00E+00	0.00E+00	0.00E+00	0.00E+00
Bis(2-ethylhexyl)phthalate	5.22E-05	1.96E-03	1.25E-04	4.69E-03	4.03E-03	6.36E-05
Chrysene	0.00E+00	0.00E+00	0.00E+00	0.00E+00	4.86E-05	7.68E-07
Dibenzo(a,h)anthracene	0.00E+00	0.00E+00	0.00E+00	0.00E+00	0.00E+00	0.00E+00
Di-n-octylphthalate	3.32E-06	1.24E-04	9.80E-07	3.68E-05	0.00E+00	0.00E+00
Fluoranthene	8.12E-07	3.04E-05	4.57E-07	1.71E-05	9.34E-03	1.48E-04
Fluorene	5.48E-07	2.06E-05	2.83E-07	1.06E-05	0.00E+00	0.00E+00
Indeno(1,2,3-c,d)pyrene	4.98E-07	1.87E-05	0.00E+00	0.00E+00	0.00E+00	0.00E+00
Naphthalene	5.33E-09	2.00E-07	2.32E-09	8.70E-08	0.00E+00	0.00E+00
Phenanthrene	9.60E-07	3.60E-05	9.78E-07	3.67E-05	1.80E-04	2.84E-06
Pyrene	0.00E+00	0.00E+00	0.00E+00	0.00E+00	9.20E-05	1.45E-06
TOTAL PAHs (16 compounds)	5.47E-06	2.05E-04	2.26E-06	8.49E-05	9.66E-03	1.53E-04
PESTICIDES						
4,4'-DDD	0.00E+00	0.00E+00	0.00E+00	0.00E+00	0.00E+00	0.00E+00
4,4'-DDE	0.00E+00	0.00E+00	0.00E+00	0.00E+00	0.00E+00	0.00E+00
4,4'-DDT	0.00E+00	0.00E+00	0.00E+00	0.00E+00	0.00E+00	0.00E+00
TOTAL DDT-DDE-DDD	0.00E+00	0.00E+00	0.00E+00	0.00E+00	0.00E+00	0.00E+00
PCBs						
Total PCBs (209 Congeners)	1.66E-06	6.22E-05	6.53E-07	2.45E-05	2.77E-05	4.38E-07
DIOXINS/FURANS						
2,3,7,8-TCDD	0.00E+00	0.00E+00	0.00E+00	0.00E+00	0.00E+00	0.00E+00
1,2,3,7,8-PeCDD	0.00E+00	0.00E+00	0.00E+00	0.00E+00	0.00E+00	0.00E+00
2,3,4,7,8-PeCDF	1.44E-10	5.41E-09	1.84E-11	6.90E-10	0.00E+00	0.00E+00
Total Dioxins/Furans (22 Congeners)	6.87E-08	2.58E-06	6.35E-10	2.38E-08	0.00E+00	0.00E+00

Appendix C: Cement-Lock Mass Balance

Process Stream Stream Number	Total Mass		Decontamination Efficiency (Total mass)	Overall Efficiency (Total mass)
	In	Out		
Units				
Total Mass	87,730	87,730		
Percent Moisture				
Dry Weight Solids	56,465	56,465		
Water	31,265	31,265		
Source of Mass				
Source of Moisture Content				
Source of Chemical Info				
Other notes				
	Mass In	Mass Out	Mass % Removed	Mass % Destroyed
	lb	lb	in Treated Solids	/ Unaccounted For
METALS				
Arsenic	6.25E-01	2.89E-01	53.78%	53.60%
Barium	7.05E+00	7.45E+00	-5.71%	-5.75%
Cadmium	2.79E-01	1.81E-02	93.85%	93.51%
Chromium	8.02E+00	4.99E+00	37.89%	37.76%
Cobalt	4.62E-01	3.35E-01	27.45%	27.39%
Copper	9.97E+00	4.45E+00	55.34%	55.27%
Lead	1.50E+01	9.89E-01	93.47%	93.39%
Manganese	1.70E+01	1.63E+01	3.85%	3.63%
Mercury	2.01E-01	6.66E-03	99.63%	96.59%
Nickel	2.01E+00	1.59E+00	20.77%	20.57%
Selenium	5.52E-02	3.92E-04	100.00%	99.28%
Silver	2.35E-01	2.52E-02	89.61%	89.24%
Zinc	2.62E+01	3.33E+00	87.38%	87.29%
TOTAL Metals	8.71E+01	3.98E+01	54.33%	54.21%
SVOCs				
Acenaphthene	4.90E-03	0.00E+00	100.00%	100.00%
Acenaphthylene	1.14E-02	1.42E-05	99.88%	99.88%
Anthracene	1.52E-02	0.00E+00	100.00%	100.00%
Benzo(a)anthracene	6.00E-02	1.10E-05	100.00%	99.98%
Benzo(a)Pyrene	5.83E-02	9.42E-06	100.00%	99.98%
Benzo(b)fluoranthene	6.59E-02	0.00E+00	100.00%	100.00%
Benzo(g,h,i)perylene	3.32E-02	0.00E+00	100.00%	100.00%
Benzo(k)fluoranthene	3.61E-02	0.00E+00	100.00%	100.00%
Bis(2-ethylhexyl)phthalate	1.11E+00	4.75E-03	100.00%	99.57%
Chrysene	5.85E-02	7.68E-07	100.00%	100.00%
Dibenzo(a,h)anthracene	4.36E-03	0.00E+00	100.00%	100.00%
Di-n-octylphthalate	3.40E-02	3.68E-05	100.00%	99.89%
Fluoranthene	1.13E-01	1.65E-04	100.00%	99.85%
Fluorene	7.13E-03	1.06E-05	100.00%	99.85%
Indeno(1,2,3-c,d)pyrene	2.75E-02	0.00E+00	100.00%	100.00%
Naphthalene	6.64E-03	8.70E-08	100.00%	100.00%
Phenanthrene	4.29E-02	3.95E-05	100.00%	99.91%
Pyrene	1.04E-01	1.45E-06	100.00%	100.00%
TOTAL PAHs (16 compounds)	6.49E-01	2.52E-04	100.00%	99.96%
PESTICIDES				
4,4'-DDD	1.17E-03	0.00E+00	100.00%	100.00%
4,4'-DDE	1.68E-03	0.00E+00	100.00%	100.00%
4,4'-DDT	7.78E-03	0.00E+00	100.00%	100.00%
TOTAL DDT-DDE-DDD	1.06E-02	0.00E+00	100.00%	100.00%
PCBs				
Total PCBs (209 Congeners)	1.12E-01	3.47E-05	99.99%	99.97%
DIOXINS/FURANS				
2,3,7,8-TCDD	3.09E-05	0.00E+00	100.00%	100.00%
1,2,3,7,8-PeCDD	9.41E-07	0.00E+00	100.00%	100.00%
2,3,4,7,8-PeCDF	3.37E-06	6.35E-08	98.13%	98.11%
Total Dioxins/Furans (22 Congeners)	8.44E-04	7.95E-07	99.91%	99.91%

Appendix C: Cement-Lock Mass Balance

Process Stream	Decontamination Efficiency (SPLP mass)	Decontamination Efficiency (TCLP mass)	Concentration Reduction to Total Product
Stream Number			Efficient
Units			
Total Mass			
Percent Moisture			
Dry Weight Solids			
Water			
Source of Mass			
Source of Moisture Content			
Source of Chemical Info			
Other notes			
METALS			
Arsenic	100.00%	100.00%	59.50%
Barium	100.00%	91.20%	7.37%
Cadmium	100.00%	98.79%	94.61%
Chromium	100.00%	99.90%	45.58%
Cobalt	100.00%	100.00%	36.43%
Copper	100.00%	99.60%	60.87%
Lead	99.89%	100.00%	94.28%
Manganese	99.77%	99.62%	15.75%
Mercury	99.92%	100.00%	99.68%
Nickel	98.72%	98.15%	30.57%
Selenium	100.00%	100.00%	100.00%
Silver	100.00%	100.00%	90.89%
Zinc	99.64%	99.00%	88.94%
TOTAL Metals	99.80%	98.81%	59.98%
SVOCs			
Acenaphthene		100.00%	100.00%
Acenaphthylene		100.00%	99.89%
Anthracene		100.00%	100.00%
Benzo(a)anthracene	100.00%	100.00%	100.00%
Benzo(a)Pyrene	100.00%	100.00%	100.00%
Benzo(b)fluoranthene	100.00%	100.00%	100.00%
Benzo(g,h,i)perylene		100.00%	100.00%
Benzo(k)fluoranthene	100.00%	100.00%	100.00%
Bis(2-ethylhexyl)phthalate	100.00%	100.00%	100.00%
Chrysene	100.00%	100.00%	100.00%
Dibenzo(a,h)anthracene		100.00%	100.00%
Di-n-octylphthalate		100.00%	100.00%
Fluoranthene		100.00%	100.00%
Fluorene		100.00%	100.00%
Indeno(1,2,3-c,d)pyrene	100.00%	100.00%	100.00%
Naphthalene		100.00%	100.00%
Phenanthrene		100.00%	100.00%
Pyrene		100.00%	100.00%
TOTAL PAHs (16 compound)	100.00%	100.00%	100.00%
PESTICIDES			
4,4'-DDD	100.00%	100.00%	100.00%
4,4'-DDE	100.00%	100.00%	100.00%
4,4'-DDT	100.00%	100.00%	100.00%
TOTAL DDT-DDE-DDD	100.00%	100.00%	100.00%
PCBs			
Total PCBs (209 Congeners)			99.99%
DIOXINS/FURANS			
2,3,7,8-TCDD			100.00%
1,2,3,7,8-PeCDD			100.00%
2,3,4,7,8-PeCDF			98.36%
Total Dioxins/Furans (22 Congeners)			99.92%

Appendix C: Cement-Lock Mass Balance

Process Stream	Concentration Reduction to SPLP-leachable Total Product	Concentration Reduction to TCLP-leachable Total Product
Stream Number	Species	
Units		
Total Mass		
Percent Moisture		
Dry Weight Solids		
Water		
Source of Mass		
Source of Moisture Content		
Source of Chemical Info		
Other notes		
METALS		
Arsenic	100.00%	100.00%
Barium	100.00%	92.29%
Cadmium	100.00%	98.94%
Chromium	100.00%	99.92%
Cobalt	100.00%	100.00%
Copper	100.00%	99.65%
Lead	99.90%	100.00%
Manganese	99.79%	99.66%
Mercury	99.93%	100.00%
Nickel	98.88%	98.38%
Selenium	100.00%	100.00%
Silver	100.00%	100.00%
Zinc	99.69%	99.12%
TOTAL Metals	99.82%	98.96%
SVOCs		
Acenaphthene		100.00%
Acenaphthylene		100.00%
Anthracene		100.00%
Benzo(a)anthracene	100.00%	100.00%
Benzo(a)Pyrene	100.00%	100.00%
Benzo(b)fluoranthene	100.00%	100.00%
Benzo(g,h,i)perylene		100.00%
Benzo(k)fluoranthene	100.00%	100.00%
Bis(2-ethylhexyl)phthalate	100.00%	100.00%
Chrysene	100.00%	100.00%
Dibenzo(a,h)anthracene		100.00%
Di-n-octylphthalate		100.00%
Fluoranthene		100.00%
Fluorene		100.00%
Indeno(1,2,3-c,d)pyrene	100.00%	100.00%
Naphthalene		100.00%
Phenanthrene		100.00%
Pyrene		100.00%
TOTAL PAHs (16 compounds)	100.00%	100.00%
PESTICIDES		
4,4'-DDD	100.00%	100.00%
4,4'-DDE	100.00%	100.00%
4,4'-DDT	100.00%	100.00%
TOTAL DDT-DDE-DDD	100.00%	100.00%
PCBs		
Total PCBs (209 Congeners)		
DIOXINS/FURANS		
2,3,7,8-TCDD		
1,2,3,7,8-PeCDD		
2,3,4,7,8-PeCDF		
Total Dioxins/Furans (22 Congeners)		

Appendix C: Cement-Lock Mass Balance

Process Stream	Melter Stage Efficiency (Total)	Melter Stage Efficiency (TCLP)	Carbon Stage Efficiency
Stream Number			
Units			
Total Mass			
Percent Moisture			
Dry Weight Solids			
Water			
Source of Mass			
Source of Moisture Content			
Source of Chemical Info	Total concentrations	TCLP concentrations	
Other notes	Used flue gas to carbon for melter flue		
METALS			
Arsenic	53.46%	99.68%	44.05%
Barium	-5.75%	91.16%	-9.36%
Cadmium	92.78%	97.72%	67.96%
Chromium	37.79%	99.80%	-27.20%
Cobalt	27.36%	99.91%	31.76%
Copper	55.30%	99.55%	-61.53%
Lead	93.39%	99.92%	7.41%
Manganese	3.28%	99.05%	62.60%
Mercury	59.80%	60.17%	92.36%
Nickel	20.43%	97.81%	41.18%
Selenium	96.23%	96.23%	81.04%
Silver	89.36%	99.75%	-50.01%
Zinc	87.22%	98.84%	42.41%
TOTAL Metals	54.03%	98.51%	59.20%
SVOCs			
Acenaphthene	99.80%	99.80%	
Acenaphthylene	99.88%	100.00%	
Anthracene	99.98%	99.98%	
Benzo(a)anthracene	99.94%	99.94%	70.53%
Benzo(a)Pyrene	99.98%	99.98%	23.72%
Benzo(b)fluoranthene	99.97%	99.97%	
Benzo(g,h,i)perylene	99.96%	99.96%	
Benzo(k)fluoranthene	100.00%	100.00%	
Bis(2-ethylhexyl)phthalate	99.82%	99.82%	-139.46%
Chrysene	100.00%	100.00%	
Dibenzo(a,h)anthracene	100.00%	100.00%	
Di-n-octylphthalate	99.63%	99.63%	70.44%
Fluoranthene	99.97%	99.97%	43.72%
Fluorene	99.71%	99.71%	48.47%
Indeno(1,2,3-c,d)pyrene	99.93%	99.93%	
Naphthalene	100.00%	100.00%	56.43%
Phenanthrene	99.92%	99.92%	-1.80%
Pyrene	100.00%	100.00%	
TOTAL PAHs (16 compounds)	99.97%	99.97%	58.60%
PESTICIDES			
4,4'-DDD	100.00%	100.00%	
4,4'-DDE	100.00%	100.00%	
4,4'-DDT	100.00%	100.00%	
TOTAL DDT-DDE-DDD	100.00%	100.00%	
PCBs			
Total PCBs (209 Congeners)	99.94%		60.62%
DIOXINS/FURANS			
2,3,7,8-TCDD	100.00%		
1,2,3,7,8-PeCDD	100.00%		
2,3,4,7,8-PeCDF	97.97%		87.26%
Total Dioxins/Furans (22 Congeners)	99.60%		99.08%

Appendix C: Cement-Lock Mass Balance

Process Stream	Ecomelt® Product	Carbon Column	Exhaust Gas	Granulator Offgas	Total Off Gases	Destroyed, Waste, or Unaccounted For
Stream Number	Chemical Fate					
Units						
Total Mass						
Percent Moisture						
Dry Weight Solids	114%	0.00%	24.5%	0.00%	24.5%	0.00%
Water	0.00%	0.00%	100.00%	102%	202%	0.00%
Source of Mass						
Source of Moisture Content						
Source of Chemical Info						
Other notes						
METALS						
Arsenic	46.22%	0.14%	0.18%	0.00%	0.18%	53.46%
Barium	105.71%	0.00%	0.04%	0.00%	0.04%	-5.75%
Cadmium	6.15%	0.73%	0.34%	0.00%	0.34%	92.78%
Chromium	62.11%	-0.03%	0.13%	0.00%	0.13%	37.79%
Cobalt	72.55%	0.03%	0.06%	0.00%	0.06%	27.36%
Copper	44.66%	-0.03%	0.07%	0.00%	0.07%	55.30%
Lead	6.53%	0.01%	0.08%	0.00%	0.08%	93.39%
Manganese	96.15%	0.36%	0.21%	0.00%	0.21%	3.28%
Mercury	0.37%	36.78%	3.04%	0.00%	3.05%	59.80%
Nickel	79.23%	0.14%	0.20%	0.00%	0.20%	20.43%
Selenium	0.00%	3.06%	0.72%	0.00%	0.72%	96.23%
Silver	10.39%	-0.12%	0.37%	0.00%	0.37%	89.36%
Zinc	12.62%	0.07%	0.09%	0.00%	0.09%	87.22%
TOTAL Metals	45.67%	0.18%	0.12%	0.00%	0.12%	54.03%
SVOCs						
Acenaphthene	0.00%	0.20%	0.00%	0.00%	0.00%	99.80%
Acenaphthylene	0.12%	0.00%	0.00%	0.00%	0.00%	99.88%
Anthracene	0.00%	0.02%	0.00%	0.00%	0.00%	99.98%
Benzo(a)anthracene	0.00%	0.04%	0.02%	0.00%	0.02%	99.94%
Benzo(a)Pyrene	0.00%	0.01%	0.02%	0.00%	0.02%	99.98%
Benzo(b)fluoranthene	0.00%	0.03%	0.00%	0.00%	0.00%	99.97%
Benzo(g,h,i)perylene	0.00%	0.04%	0.00%	0.00%	0.00%	99.96%
Benzo(k)fluoranthene	0.00%	0.00%	0.00%	0.00%	0.00%	100.00%
Bis(2-ethylhexyl)phthalate	0.00%	-0.25%	0.42%	0.01%	0.43%	99.82%
Chrysene	0.00%	0.00%	0.00%	0.00%	0.00%	100.00%
Dibenzo(a,h)anthracene	0.00%	0.00%	0.00%	0.00%	0.00%	100.00%
Di-n-octylphthalate	0.00%	0.26%	0.11%	0.00%	0.11%	99.63%
Fluoranthene	0.00%	0.01%	0.02%	0.13%	0.15%	99.84%
Fluorene	0.00%	0.14%	0.15%	0.00%	0.15%	99.71%
Indeno(1,2,3-c,d)pyrene	0.00%	0.07%	0.00%	0.00%	0.00%	99.93%
Naphthalene	0.00%	0.00%	0.00%	0.00%	0.00%	100.00%
Phenanthrene	0.00%	0.00%	0.09%	0.01%	0.09%	99.91%
Pyrene	0.00%	0.00%	0.00%	0.00%	0.00%	100.00%
TOTAL PAHs (16 compounds)	0.0022%	0.02%	0.01%	0.02%	0.037%	99.94%
PESTICIDES						
4,4'-DDD	0.00%	0.00%	0.00%	0.00%	0.00%	100.00%
4,4'-DDE	0.00%	0.00%	0.00%	0.00%	0.00%	100.00%
4,4'-DDT	0.00%	0.00%	0.00%	0.00%	0.00%	100.00%
TOTAL DDT-DDE-DDD	0.00%	0.00%	0.00%	0.00%	0.00%	100.00%
PCBs						
Total PCBs (209 Congeners)	0.0087%	0.0336%	0.0218%	0.0004%	0.0222%	99.94%
DIOXINS/FURANS						
2,3,7,8-TCDD	0.0000%	0.0000%	0.0000%	0.0000%	0.0000%	100.00%
1,2,3,7,8-PeCDD	0.0000%	0.0000%	0.0000%	0.0000%	0.0000%	100.00%
2,3,4,7,8-PeCDF	1.8669%	0.1404%	0.0205%	0.0000%	0.0205%	97.97%
Total Dioxins/Furans (22 Congeners)	0.0914%	0.3025%	0.0028%	0.0000%	0.0028%	99.60%

Appendix D: Minergy Mass Balance

The enclosed tables support mass balance calculations reflected in the following:

- Chapter 2
 - Table 11
 - Figure 9
- Chapter 3
 - Tables 21 and 22
 - Figures 25-30
- Chapter 6
 - Table 33
 - Figure 44

Appendix D: Minergy Glass Furnace Technology Mass Balance

Process Stream	Dewatered Sediment to Dryer		Solids from Dryer		Condensate from Dryer	
Stream Number	1		2		3	
Units	lb		lb		lb	
Total Mass	27,000		15,000		12,000	
Percent Moisture	50.0%		10.0%		100.0%	
Mass Organic Matter (Volatile Solids)	2,295		2,295			
Dry Mass (Fixed) Solids	11,205		11,205			
Dry Mass Total Solids	13,500		13,500			
Mass Water	13,500		1,500		12,000	
Source of Mass	USEPA (2004) p. 24. Volatile solids 17% of total solids (Blue/bold numbers)		Calculated based on moisture change		Calculated based on moisture change	
Source of Moisture Content	USEPA (2004) pp 41-42 (Blue/bold numbers)		USEPA (2004) pp 41-42 (Blue/bold numbers)		Assumed 100%	
Source of Chemical Info	USEPA (2004) Table 4-2 for PCBs; Table C-1 for others (Blue/bold numbers)		USEPA (2004) Table 4-2 for PCBs; Table C-2 for others		USEPA (2004) Table C-3 for PCBs and metals	
Other notes	Hazen dryer data for PCBs incompatible with pilot melter data				Dryer test separate from melter test. PCB measured differently	
	Conc	Mass	Conc	Mass	Conc	Mass
	mg/kg	lb	mg/kg	lb	mg/L	lb
METALS						
Arsenic	9.30E+00	1.04E-01	8.03E+00	9.00E-02	2.63E-02	3.15E-04
Barium	8.28E+01	9.28E-01	7.92E+01	8.87E-01	1.70E-02	2.04E-04
Cadmium	9.65E-01	1.08E-02	9.32E-01	1.04E-02	0.00E+00	0.00E+00
Chromium	3.77E+01	4.22E-01	3.60E+01	4.03E-01	0.00E+00	0.00E+00
Mercury	9.02E-01	1.01E-02	8.60E-01	9.64E-03	2.15E-04	2.58E-06
Lead	7.37E+01	8.25E-01	7.02E+01	7.86E-01	6.33E-03	7.59E-05
Selenium	4.55E+00	5.10E-02	5.52E+00	6.18E-02	0.00E+00	0.00E+00
Silver	0.00E+00	0.00E+00	0.00E+00	0.00E+00	0.00E+00	0.00E+00
Total Metals		2.35E+00		2.25E+00		5.97E-04
ORGANICS						
Total PCBs	2.94E+01	3.29E-01	2.24E+01	2.51E-01	4.30E-01	5.16E-03
Total SVOCs	1.98E-01	2.22E-03	2.14E+00	2.40E-02	2.20E-01	2.64E-03
T PCDDs/PCDFs	1.54E-02	1.73E-04	5.20E-02	5.83E-04	1.06E-05	1.28E-07

Appendix D: Minergy Glass Furnace Technology Mass Balance

Process Stream	Dried Sediment to Melter		Flux Added to Melter		Glass Aggregate from System	
Stream Number	4		5		6	
Units	lb		lb		lb	
Total Mass	15,000		750		11,000	
Percent Moisture	10%		0.3%		0.0%	
Mass Organic Matter (Volatile Solids)	2,295					
Dry Mass (Fixed) Solids	11,205		748		11,000	
Dry Mass Total Solids	13,500		748		11,000	
Mass Water	1,500		2		0	
Source of Mass	USEPA (2004) p. 24		5% flux reported in USEPA (2004)		Reported product mass USEPA (2004)	
Source of Moisture Content	USEPA (2004) pp 41-42		Assumed			
Source of Chemical Info	USEPA (2004) Table 4-4		USEPA (2004) Table 4-5		USEPA (2004) Table 4-6	
Other notes	Assume feed is 17% volatile solids		Sodium sulfate used for demo			
	Conc	Mass	Conc	Mass	Conc	Mass
	mg/kg	lb	mg/kg	lb	mg/kg	lb
METALS						
Arsenic	6.27E+00	7.02E-02	0.00E+00	0.00E+00	0.00E+00	0.00E+00
Barium	8.77E+01	9.82E-01	0.00E+00	0.00E+00	3.28E+02	3.61E+00
Cadmium	8.78E-01	9.84E-03	0.00E+00	0.00E+00	0.00E+00	0.00E+00
Chromium	3.77E+01	4.22E-01	0.00E+00	0.00E+00	5.02E+01	5.52E-01
Mercury	7.18E-01	8.05E-03	0.00E+00	0.00E+00	0.00E+00	0.00E+00
Lead	7.18E+01	8.05E-01	0.00E+00	0.00E+00	1.42E+01	1.56E-01
Selenium	4.48E+00	5.02E-02	0.00E+00	0.00E+00	4.90E+00	5.39E-02
Silver	0.00E+00	0.00E+00	0.00E+00	0.00E+00	0.00E+00	0.00E+00
Total Metals		2.35E+00		0.00E+00		4.37E+00
ORGANICS						
Total PCBs	2.81E+01	3.14E-01	7.90E-04	5.91E-07	4.12E-04	4.53E-06
Total SVOCs	5.44E+02	6.09E+00	0.00E+00	0.00E+00	0.00E+00	0.00E+00
T PCDDs/PCDFs	1.18E-01	1.32E-03	5.07E-06	3.79E-09	2.37E-06	2.61E-08

Appendix D: Minergy Glass Furnace Technology Mass Balance

Process Stream	Flue Gas from Melter		Flue Gas After Carbon Treatment		Quench Water	
Stream Number	7		8		9	
Units	lb		lb		lb	
Total Mass	3,797		1,298		0	
Percent Moisture						
Mass Organic Matter (Volatile Solids)	2,295		1,148			
Dry Mass (Fixed) Solids						
Dry Mass Total Solids	2,295		1,148		0	
Mass Water	1,502		150		0	
Source of Mass	Assume all water and volatiles in gas--burner gas not accounted for		Assume 50% volatile organic matter and 10% water not condensed		Assume quench water is cooled and recycled	
Source of Moisture Content						
Source of Chemical Info	USEPA (2004) Table 4-7		USEPA (2004) Table 4-8		USEPA (2004) Table 4-9	
Other notes	Assume 1dscm=1 kg; Organic matter to CO2 and H2O		Carbon canister not analyzed			
	Conc	Mass	Conc	Mass	Conc	Mass
	ng/dscm	lb	ng/dscm	lb	mg/L	lb
METALS						
Arsenic	0.00E+00	0.00E+00	0.00E+00	0.00E+00	0.00E+00	0.00E+00
Barium	0.00E+00	0.00E+00	0.00E+00	0.00E+00	2.25E-02	0.00E+00
Cadmium	0.00E+00	0.00E+00	0.00E+00	0.00E+00	0.00E+00	0.00E+00
Chromium	0.00E+00	0.00E+00	0.00E+00	0.00E+00	0.00E+00	0.00E+00
Mercury	0.00E+00	0.00E+00	0.00E+00	0.00E+00	0.00E+00	0.00E+00
Lead	0.00E+00	0.00E+00	0.00E+00	0.00E+00	0.00E+00	0.00E+00
Selenium	0.00E+00	0.00E+00	0.00E+00	0.00E+00	0.00E+00	0.00E+00
Silver	0.00E+00	0.00E+00	0.00E+00	0.00E+00	0.00E+00	0.00E+00
Total Metals		0.00E+00		0.00E+00		0.00E+00
ORGANICS						
Total PCBs	4.85E+01	1.84E-07	3.76E+01	4.87E-08	4.90E-07	0.00E+00
Total SVOCs	1.73E+05	6.55E-04	1.13E+04	1.47E-05	0.00E+00	0.00E+00
T PCDDs/PCDFs	1.59E+00	6.04E-09	8.55E-03	1.11E-11	0.00E+00	0.00E+00

Appendix D: Minergy Glass Furnace Technology Mass Balance

Process Stream	Cooling Water Discharge		Dust in Flue Gas	
Stream Number	10		11	
Units	lb		lb	
Total Mass	2,499		0	
Percent Moisture				
Mass Organic Matter (Volatile Solids)	1,148			
Dry Mass (Fixed) Solids				
Dry Mass Total Solids	1,148		0	
Mass Water	1,352		0	
Source of Mass	Includes condensed volatile matter and water--blowdown not included		Assume all dust collected and recycled	
Source of Moisture Content				
Source of Chemical Info	USEPA (2004) Table 4-10		USEPA (2004) Table 4-11	
Other notes	Neutralizing chemical (caustic) not included			
	Conc	Mass	Conc	Mass
	mg/L	lb	mg/kg	lb
METALS				
Arsenic	2.50E-01	6.25E-04	1.12E+02	0.00E+00
Barium	3.77E-02	9.41E-05	2.17E+02	0.00E+00
Cadmium	2.97E-02	7.41E-05	1.63E+01	0.00E+00
Chromium	1.18E+00	2.95E-03	2.27E+02	0.00E+00
Mercury	4.15E-02	1.04E-04	7.03E-01	0.00E+00
Lead	2.07E+00	5.16E-03	1.02E+03	0.00E+00
Selenium	0.00E+00	0.00E+00	4.23E+01	0.00E+00
Silver	0.00E+00	0.00E+00	6.63E+00	0.00E+00
Total Metals		9.01E-03		0.00E+00
ORGANICS				
Total PCBs	2.85E-06	7.12E-09	0.00E+00	0.00E+00
Total SVOCs	0.00E+00	0.00E+00	0.00E+00	0.00E+00
T PCDDs/PCDFs	0.00E+00	0.00E+00	3.49E-06	0.00E+00

Appendix D: Minergy Glass Furnace Technology Mass Balance

Process Stream							
Stream Number							
Units							
Total Mass							
Percent Moisture							
Mass Organic Matter (Volatile Solids)							
Dry Mass (Fixed) Solids							
Dry Mass Total Solids							
Mass Water							
Source of Mass							
Source of Moisture Content							
Source of Chemical Info							
Other notes							
		Dryer Stage			Melter Stage		
		Mass In	Mass Out	Mass Un-Acct-For	Mass In	Mass Out	Mass Un-Acct-For
		lb	lb	pct	lb	lb	pct
METALS							
Arsenic		1.04E-01	9.03E-02	13.32%	7.02E-02	0.00E+00	100%
Barium		9.28E-01	8.87E-01	4.40%	9.82E-01	3.61E+00	-268%
Cadmium		1.08E-02	1.04E-02	3.45%	9.84E-03	0.00E+00	100%
Chromium		4.22E-01	4.03E-01	4.42%	4.22E-01	5.52E-01	-31%
Mercury		1.01E-02	9.64E-03	4.60%	8.05E-03	0.00E+00	100%
Lead		8.25E-01	7.86E-01	4.74%	8.05E-01	1.56E-01	81%
Selenium		5.10E-02	6.18E-02	-21.25%	5.02E-02	5.39E-02	-7%
Silver		0.00E+00	0.00E+00	0.00%	0.00E+00	0.00E+00	0%
Total Metals		2.35E+00	2.25E+00	4%	2.35E+00	4.37E+00	-86%
ORGANICS							
Total PCBs		3.29E-01	2.56E-01	22%	3.14E-01	4.72E-06	100%
Total SVOCs		2.22E-03	2.66E-02	-1100%	6.09E+00	6.55E-04	100%
T PCDDs/PCDFs		1.73E-04	5.83E-04	-238%	1.32E-03	3.21E-08	100%

Appendix D: Minery Glass Furnace Technology Mass Balance

Process Stream						
Stream Number						
Units						
Total Mass						
Percent Moisture						
Mass Organic Matter (Volatile Solids)						
Dry Mass (Fixed) Solids						
Dry Mass Total Solids						
Mass Water						
Source of Mass						
Source of Moisture Content						
Source of Chemical Info						
Other notes						
	Emission Control Stage			Overall Efficiency		
	Mass In	Mass Out	Mass Un-Acct-For	Mass In	Mass Out	Mass Un-Acct-For
	lb	lb	pct	lb	lb	pct
METALS						
Arsenic	0.00E+00	6.25E-04	NA	7.02E-02	6.25E-04	99.1%
Barium	0.00E+00	9.41E-05	NA	9.82E-01	3.61E+00	-267.7%
Cadmium	0.00E+00	7.41E-05	NA	9.84E-03	7.41E-05	99.2%
Chromium	0.00E+00	2.95E-03	NA	4.22E-01	5.55E-01	-31.4%
Mercury	0.00E+00	1.04E-04	NA	8.05E-03	1.04E-04	98.7%
Lead	0.00E+00	5.16E-03	NA	8.05E-01	1.61E-01	80.0%
Selenium	0.00E+00	0.00E+00	NA	5.02E-02	5.39E-02	-7.3%
Silver	0.00E+00	0.00E+00	NA	0.00E+00	0.00E+00	0.0%
Total Metals	0.00E+00	9.01E-03		2.35E+00	4.38E+00	-86.67%
ORGANICS						
Total PCBs	1.84E-07	5.59E-08	70%	3.14E-01	4.59E-06	99.9985%
Total SVOCs	6.55E-04	1.47E-05	98%	6.09E+00	1.47E-05	100%
T PCDDs/PCDFs	6.04E-09	1.11E-11	100%	1.32E-03	2.61E-08	100%

Appendix D: Minergy Glass Furnace Technology Mass Balance

Process Stream			
Stream Number			
Units			
Total Mass			
Percent Moisture			
Mass Organic Matter (Volatile Solids)			
Dry Mass (Fixed) Solids			
Dry Mass Total Solids			
Mass Water			
Source of Mass			
Source of Moisture Content			
Source of Chemical Info			
Other notes			
Decontamination Efficiency			
	Mass In	Mass Out	Mass Un-Acct-For
	lb	lb	pct
METALS			
Arsenic	7.02E-02	0.00E+00	100.00%
Barium	9.82E-01	3.61E+00	-267.67%
Cadmium	9.84E-03	0.00E+00	100.00%
Chromium	4.22E-01	5.52E-01	-30.75%
Mercury	8.05E-03	0.00E+00	100.00%
Lead	8.05E-01	1.56E-01	80.64%
Selenium	5.02E-02	5.39E-02	-7.29%
Silver	0.00E+00	0.00E+00	0.0000%
Total Metals	2.35E+00	4.37E+00	-86.29%
ORGANICS			
Total PCBs	3.14E-01	4.53E-06	99.9986%
Total SVOCs	6.09E+00	0.00E+00	100.0000%
T PCDDs/PCDFs	1.32E-03	2.61E-08	99.9980%

Appendix D: Minergy Glass Furnace Technology Mass Balance

Process Stream					
Stream Number					
Units					
Total Mass					
Percent Moisture					
Mass Organic Matter (Volatile Solids)					
Dry Mass (Fixed) Solids					
Dry Mass Total Solids					
Mass Water					
Source of Mass					
Source of Moisture Content					
Source of Chemical Info					
Other notes					
Chemical Fate (% of Feed Mass)					
	Glass Aggr Product	Off Gases	Particulates	Wastewater	Destroyed or Unacct for
METALS					
Arsenic	0.0%	0.0000%	0.0000%	0.902%	99.10%
Barium	389.1%	0.0000%	0.0000%	0.032%	-289.16%
Cadmium	0.0%	0.0000%	0.0000%	0.686%	99.31%
Chromium	130.7%	0.0000%	0.0000%	0.699%	-31.45%
Mercury	0.0%	0.0000%	0.0000%	1.053%	98.95%
Lead	18.9%	0.0000%	0.0000%	0.635%	80.49%
Selenium	105.7%	0.0000%	0.0000%	0.000%	-5.72%
Silver					
Total Metals	186%	0.0000%	0.0000%	0.409%	-86.4%
ORGANICS					
Total PCBs	0.00138%	0.0000%	0.0000%	1.57%	98.4%
Total SVOCs	0.0000%	0.661%	0.0000%	119%	-19.7%
T PCDDs/PCDFs	0.0151%	0.0000%	0.0000%	0.074%	99.9%

Appendix E: Biogenesissm WRDA NYNJ Harbor Demonstration Mass Balance

The enclosed tables support mass balance calculations reflected in the following:

- Chapter 2
 - Tables 13 and 15
 - Figure 11
- Chapter 3
 - Tables 23-25
 - Figures 31, 33-36

Appendix E. BiogenesisSM Mass Balance--NY/NJ Harbor Demonstration (1999)

Process Stream	Untreated Sediment Feed to Pre-Processor					Process Water Addition to Pre-Processor	
Stream Number	1					2	
Total Mass Input, lbs	15,386					9,013	
Total Solids Concentration, %	33.16%					0	
Mass Dry Weight Solids, lbs	5,102						
Mass Water, lbs	10,284					9,013	
Source of Mass	Biogenesis & Weston 1999, Appendix E						
Source of Solids Concentration	Biogenesis & Weston 1999, Appendix E						
Source of Chemical Data	Biogenesis & Weston 1999, Appendix D						
Other Notes	Bold blue entries represent measured input values						
	Solids		Liquids		Total	Liquids	
	Conc.	Mass	Conc.	Mass	Mass	Conc.	Mass
	mg/kg	lbs	µg/L	lbs	lbs	µg/L	lbs
METALS							
Antimony	5.40E-02	2.76E-04	3.91E+01	4.02E-04	6.77E-04	0.00E+00	0.00E+00
Arsenic	1.23E+01	6.28E-02	5.61E+02	5.77E-03	6.85E-02	2.10E-01	1.89E-06
Beryllium	8.60E-01	4.39E-03	3.83E+01	3.94E-04	4.78E-03	0.00E+00	0.00E+00
Cadmium	3.13E+00	1.60E-02	1.80E+02	1.85E-03	1.78E-02	0.00E+00	0.00E+00
Chromium	1.69E+02	8.64E-01	1.00E+04	1.03E-01	9.67E-01	2.10E-01	1.89E-06
Copper	1.65E+02	8.40E-01	1.04E+04	1.07E-01	9.47E-01	9.00E+00	8.11E-05
Lead	1.57E+02	7.99E-01	9.08E+03	9.34E-02	8.93E-01	1.00E+00	9.01E-06
Nickel	3.24E+01	1.65E-01	1.48E+03	1.52E-02	1.80E-01	1.10E+00	9.91E-06
Selenium	9.80E-01	5.00E-03	2.61E+01	2.69E-04	5.27E-03	0.00E+00	0.00E+00
Silver	3.30E+00	1.68E-02	2.55E+02	2.63E-03	1.95E-02	0.00E+00	0.00E+00
Thallium	2.10E-01	1.07E-03	5.57E+00	5.72E-05	1.13E-03	0.00E+00	0.00E+00
Zinc	2.79E+02	1.42E+00	1.49E+04	1.53E-01	1.57E+00	2.17E+02	1.96E-03
Mercury	3.90E+00	1.99E-02	2.23E+02	2.29E-03	2.22E-02	0.00E+00	0.00E+00
PAHs							
Acenaphthene	0.00E+00	0.00E+00	5.60E+00	5.76E-05	5.76E-05	0.00E+00	0.00E+00
Acenaphthylene	0.00E+00	0.00E+00	0.00E+00	0.00E+00	0.00E+00	0.00E+00	0.00E+00
Anthracene	1.47E+03	7.48E-03	4.53E+00	4.66E-05	7.53E-03	0.00E+00	0.00E+00
Benzo(a)anthracene	2.43E+03	1.24E-02	5.63E+00	5.79E-05	1.25E-02	0.00E+00	0.00E+00
Benzo(a)pyrene	2.43E+03	1.24E-02	0.00E+00	0.00E+00	1.24E-02	0.00E+00	0.00E+00
Benzo(b)fluoranthene	2.13E+03	1.09E-02	5.37E+00	5.52E-05	1.09E-02	0.00E+00	0.00E+00
Benzo(k)fluoranthene	1.70E+03	8.67E-03	5.47E+00	5.62E-05	8.73E-03	0.00E+00	0.00E+00
Benzo(ghi)perylene	1.53E+03	7.81E-03	5.40E+00	5.55E-05	7.86E-03	0.00E+00	0.00E+00
Chrysene	2.77E+03	1.41E-02	5.77E+00	5.93E-05	1.42E-02	0.00E+00	0.00E+00
Dibenz(a,h)anthracene	6.33E+02	3.23E-03	0.00E+00	0.00E+00	3.23E-03	0.00E+00	0.00E+00
Dibenzofuran	0.00E+00	0.00E+00	0.00E+00	0.00E+00	0.00E+00	0.00E+00	0.00E+00
1,2-Dichlorobenzene	0.00E+00	0.00E+00	0.00E+00	0.00E+00	0.00E+00	0.00E+00	0.00E+00
Fluoranthene	6.50E+03	3.32E-02	5.43E+00	5.59E-05	3.32E-02	0.00E+00	0.00E+00
Fluorene	0.00E+00	0.00E+00	5.47E+00	5.62E-05	5.62E-05	0.00E+00	0.00E+00
Hexachlorobenzene	0.00E+00	0.00E+00	0.00E+00	0.00E+00	0.00E+00	0.00E+00	0.00E+00
Indeno(1,2,3-cd)pyrene	1.68E+03	8.57E-03	0.00E+00	0.00E+00	8.57E-03	0.00E+00	0.00E+00
2-Methylnaphthalene	0.00E+00	0.00E+00	0.00E+00	0.00E+00	0.00E+00	0.00E+00	0.00E+00
Naphthalene	0.00E+00	0.00E+00	6.03E+00	6.20E-05	6.20E-05	0.00E+00	0.00E+00
Nitrobenzene	0.00E+00	0.00E+00	0.00E+00	0.00E+00	0.00E+00	0.00E+00	0.00E+00
Phenanthrene	5.20E+03	2.65E-02	2.93E+00	3.02E-05	2.66E-02	0.00E+00	0.00E+00
Pyrene	4.60E+03	2.35E-02	4.03E+00	4.15E-05	2.35E-02	0.00E+00	0.00E+00
Pesticides							
4,4'-DDE	4.17E+01	2.13E-04	1.60E-01	1.65E-06	2.14E-04	0.00E+00	0.00E+00
4,4'-DDD	2.53E+01	1.29E-04	6.33E-02	6.51E-07	1.30E-04	0.00E+00	0.00E+00
4,4'-DDT	1.27E+01	6.45E-05	0.00E+00	0.00E+00	6.45E-05	0.00E+00	0.00E+00
PCB Aroclors							
A 1254	3.03E+02	1.55E-03	1.03E+00	1.06E-05	1.56E-03	0.00E+00	0.00E+00
A1260	2.13E+02	1.09E-03	0.00E+00	0.00E+00	1.09E-03	0.00E+00	0.00E+00
PCB Congeners							
Furans							
TCDFs (total)	3.13E+02	1.60E-06	3.50E+04	3.60E-04	3.62E-04	0.00E+00	0.00E+00
2,3,7,8-TCDF	1.57E+01	7.99E-08	1.30E+03	1.34E-05	1.34E-05	0.00E+00	0.00E+00
Dioxins							
TCDDs (total)	2.42E+02	1.24E-06	1.23E+04	1.27E-04	1.28E-04	0.00E+00	0.00E+00
2,3,7,8-TCDD	9.13E+01	4.66E-07	7.63E+03	7.85E-05	7.90E-05	0.00E+00	0.00E+00
TEQ (Calculated)	1.28E+02	6.53E-07	1.17E+04	1.20E-04	1.21E-04	0.00E+00	0.00E+00
Totals by class							
Total Metals					4.70E+00		2.06E-03
Total PAHs						1.69E-01	0.00E+00
Total PCBs (Aroclors)						2.65E-03	0.00E+00
Total PCBs (Homologues)						3.56E-01	1.10E-04
Total Dioxins/Furans						6.82E-03	0.00E+00

Appendix E. BiogenesisSM Mass Balance--NY/NJ Harbor Demonstration (1999)

Process Stream	Preprocessor Outlet (PPO) (Collision Chamber Inlet)					Process Water Addition to Collision Chamber	
Stream Number	3					4	
Total Mass Input, lbs	24,399					8,312	
Total Solids Concentration, %	0					0	
Mass Dry Weight Solids, lbs	5,102					0	
Mass Water, lbs	19,297					8,312	
Source of Mass							
Source of Solids Concentration							
Source of Chemical Data							
Other Notes							
	Solids		Liquids		Total	Liquids	
	Conc.	Mass	Conc.	Mass	Mass	Conc.	Mass
	mg/kg	lbs	µg/L	lbs	lbs	µg/L	lbs
METALS							
Antimony	6.10E-02	3.11E-04	0.00E+00	0.00E+00	3.11E-04	0.00E+00	0.00E+00
Arsenic	1.11E+01	5.65E-02	7.24E+01	1.40E-03	5.79E-02	2.10E-01	1.75E-06
Beryllium	7.33E-01	3.74E-03	3.26E+00	6.28E-05	3.80E-03	0.00E+00	0.00E+00
Cadmium	2.33E+00	1.19E-02	1.53E+01	2.95E-04	1.22E-02	0.00E+00	0.00E+00
Chromium	1.20E+02	6.12E-01	7.86E+02	1.52E-02	6.27E-01	2.10E-01	1.75E-06
Copper	1.06E+02	5.41E-01	8.27E+02	1.60E-02	5.57E-01	9.00E+00	7.48E-05
Lead	1.16E+02	5.93E-01	2.40E+03	4.62E-02	6.39E-01	1.00E+00	8.31E-06
Nickel	3.51E+01	1.79E-01	1.42E+02	2.74E-03	1.82E-01	1.10E+00	9.14E-06
Selenium	7.67E-01	3.91E-03	7.37E+00	1.42E-04	4.05E-03	0.00E+00	0.00E+00
Silver	2.10E+00	1.07E-02	1.68E+01	3.24E-04	1.10E-02	0.00E+00	0.00E+00
Thallium	2.43E-01	1.24E-03	1.15E+00	2.23E-05	1.26E-03	0.00E+00	0.00E+00
Zinc	2.26E+02	1.15E+00	1.87E+03	3.61E-02	1.19E+00	2.17E+02	1.80E-03
Mercury	3.03E+00	1.55E-02	1.57E+01	3.03E-04	1.58E-02	0.00E+00	0.00E+00
PAHs	µg/kg	lbs	µg/L	lbs	lbs	µg/L	lbs
Acenaphthene	0.00E+00	0.00E+00	0.00E+00	0.00E+00	0.00E+00	0.00E+00	0.00E+00
Acenaphthylene	0.00E+00	0.00E+00	0.00E+00	0.00E+00	0.00E+00	0.00E+00	0.00E+00
Anthracene	0.00E+00	0.00E+00	0.00E+00	0.00E+00	0.00E+00	0.00E+00	0.00E+00
Benzo(a)anthracene	1.63E+03	8.33E-03	0.00E+00	0.00E+00	8.33E-03	0.00E+00	0.00E+00
Benzo(a)pyrene	1.57E+03	7.99E-03	0.00E+00	0.00E+00	7.99E-03	0.00E+00	0.00E+00
Benzo(b)fluoranthene	1.27E+03	6.46E-03	0.00E+00	0.00E+00	6.46E-03	0.00E+00	0.00E+00
Benzo(k)fluoranthene	1.30E+03	6.63E-03	0.00E+00	0.00E+00	6.63E-03	0.00E+00	0.00E+00
Benzo(ghi)perylene	1.07E+03	5.44E-03	0.00E+00	0.00E+00	5.44E-03	0.00E+00	0.00E+00
Chrysene	1.80E+03	9.18E-03	0.00E+00	0.00E+00	9.18E-03	0.00E+00	0.00E+00
Dibenz(a,h)anthracene	3.03E+02	1.55E-03	0.00E+00	0.00E+00	1.55E-03	0.00E+00	0.00E+00
Dibenzofuran	0.00E+00	0.00E+00	0.00E+00	0.00E+00	0.00E+00	0.00E+00	0.00E+00
1,2-Dichlorobenzene	0.00E+00	0.00E+00	0.00E+00	0.00E+00	0.00E+00	0.00E+00	0.00E+00
Fluoranthene	3.10E+03	1.58E-02	5.32E+00	1.03E-04	1.59E-02	0.00E+00	0.00E+00
Fluorene	0.00E+00	0.00E+00	0.00E+00	0.00E+00	0.00E+00	0.00E+00	0.00E+00
Hexachlorobenzene	0.00E+00	0.00E+00	0.00E+00	0.00E+00	0.00E+00	0.00E+00	0.00E+00
Indeno(1,2,3-cd)pyrene	1.01E+03	5.17E-03	0.00E+00	0.00E+00	5.17E-03	0.00E+00	0.00E+00
2-Methylnaphthalene	0.00E+00	0.00E+00	0.00E+00	0.00E+00	0.00E+00	0.00E+00	0.00E+00
Naphthalene	0.00E+00	0.00E+00	0.00E+00	0.00E+00	0.00E+00	0.00E+00	0.00E+00
Nitrobenzene	0.00E+00	0.00E+00	0.00E+00	0.00E+00	0.00E+00	0.00E+00	0.00E+00
Phenanthrene	1.20E+03	6.12E-03	0.00E+00	0.00E+00	6.12E-03	0.00E+00	0.00E+00
Pyrene	2.33E+03	1.19E-02	5.93E+00	1.14E-04	1.20E-02	0.00E+00	0.00E+00
Pesticides	µg/kg	lbs	µg/L	lbs	lbs	µg/L	lbs
4,4'-DDE	0.00E+00	0.00E+00	0.00E+00	0.00E+00	0.00E+00	0.00E+00	0.00E+00
4,4'-DDD	0.00E+00	0.00E+00	0.00E+00	0.00E+00	0.00E+00	0.00E+00	0.00E+00
4,4'-DDT	0.00E+00	0.00E+00	0.00E+00	0.00E+00	0.00E+00	0.00E+00	0.00E+00
PCB Aroclors	µg/kg	lbs	µg/L	lbs	lbs	µg/L	lbs
A 1254	2.57E+02	1.31E-03	6.67E-01	1.29E-05	1.32E-03	0.00E+00	0.00E+00
A1260	7.43E+01	3.79E-04	0.00E+00	0.00E+00	3.79E-04	0.00E+00	0.00E+00
PCB Congeners	pg/g	lbs	pg/L	lbs	lbs	pg/L	lbs
Furans	pg/g	lbs	pg/L	lbs	lbs	pg/L	lbs
TCDFs (total)	0.00E+00	0.00E+00	0.00E+00	0.00E+00	0.00E+00	0.00E+00	0.00E+00
2,3,7,8-TCDF	0.00E+00	0.00E+00	0.00E+00	0.00E+00	0.00E+00	0.00E+00	0.00E+00
Dioxins	pg/g	lbs	pg/L	lbs	lbs	pg/L	lbs
TCDDs (total)	0.00E+00	0.00E+00	0.00E+00	0.00E+00	0.00E+00	0.00E+00	0.00E+00
2,3,7,8-TCDD	0.00E+00	0.00E+00	0.00E+00	0.00E+00	0.00E+00	0.00E+00	0.00E+00
TEQ (Calculated)	0.00E+00	0.00E+00	0.00E+00	0.00E+00	0.00E+00	0.00E+00	0.00E+00
Totals by class							
Total Metals					3.30E+00		1.90E-03
Total PAHs					8.48E-02		0.00E+00
Total PCBs (Aroclors)					1.70E-03		0.00E+00
Total PCBs (Homologues)					0.00E+00		1.01E-04
Total Dioxins/Furans					0.00E+00		0.00E+00

Appendix E. Biogenesis™ Mass Balance--NY/NJ Harbor Demonstration (1999)

Process Stream	Collision Chamber Outlet (CCO) (Oxidation/Cavitation Inlet)					Process Water Addition to Oxidation/Cavitation	
Stream Number	5					6	
Total Mass Input, lbs	32,711					136	
Total Solids Concentration, %	0					0	
Mass Dry Weight Solids, lbs	5,102					0	
Mass Water, lbs	27,609					136	
Source of Mass							
Source of Solids Concentration							
Source of Chemical Data							
Other Notes							
	Solids		Liquids		Total	Liquids	
	Conc.	Mass	Conc.	Mass	Mass	Conc.	Mass
	mg/kg	lbs	µg/L	lbs	lbs	µg/L	lbs
METALS							
Antimony	6.27E-02	3.20E-04	0.00E+00	0.00E+00	3.20E-04	0.00E+00	0.00E+00
Arsenic	1.29E+01	6.60E-02	3.74E+01	1.03E-03	6.70E-02	2.10E-01	2.86E-08
Beryllium	8.97E-01	4.57E-03	1.02E+00	2.81E-05	4.60E-03	0.00E+00	0.00E+00
Cadmium	3.47E+00	1.77E-02	1.62E+01	4.46E-04	1.81E-02	0.00E+00	0.00E+00
Chromium	1.78E+02	9.08E-01	3.43E+02	9.48E-03	9.18E-01	2.10E-01	2.86E-08
Copper	1.78E+02	9.07E-01	3.36E+02	9.29E-03	9.16E-01	9.00E+00	1.22E-06
Lead	1.56E+02	7.98E-01	1.56E+03	4.31E-02	8.41E-01	1.00E+00	1.36E-07
Nickel	4.07E+01	2.08E-01	7.87E+01	2.17E-03	2.10E-01	1.10E+00	1.50E-07
Selenium	9.87E-01	5.03E-03	0.00E+00	0.00E+00	5.03E-03	0.00E+00	0.00E+00
Silver	3.43E+00	1.75E-02	5.33E+00	1.47E-04	1.77E-02	0.00E+00	0.00E+00
Thallium	2.43E-01	1.24E-03	9.67E-01	2.67E-05	1.27E-03	0.00E+00	0.00E+00
Zinc	2.92E+02	1.49E+00	1.17E+03	3.24E-02	1.52E+00	2.17E+02	2.95E-05
Mercury	3.23E+00	1.65E-02	7.13E+00	1.97E-04	1.67E-02	0.00E+00	0.00E+00
PAHs	µg/kg	lbs	µg/L	lbs	lbs	µg/L	lbs
Acenaphthene	0.00E+00	0.00E+00	0.00E+00	0.00E+00	0.00E+00	0.00E+00	0.00E+00
Acenaphthylene	0.00E+00	0.00E+00	0.00E+00	0.00E+00	0.00E+00	0.00E+00	0.00E+00
Anthracene	0.00E+00	0.00E+00	0.00E+00	0.00E+00	0.00E+00	0.00E+00	0.00E+00
Benzo(a)anthracene	1.87E+03	9.52E-03	0.00E+00	0.00E+00	9.52E-03	0.00E+00	0.00E+00
Benzo(a)pyrene	1.93E+03	9.86E-03	0.00E+00	0.00E+00	9.86E-03	0.00E+00	0.00E+00
Benzo(b)fluoranthene	1.73E+03	8.84E-03	0.00E+00	0.00E+00	8.84E-03	0.00E+00	0.00E+00
Benzo(k)fluoranthene	1.25E+03	6.38E-03	0.00E+00	0.00E+00	6.38E-03	0.00E+00	0.00E+00
Benzo(ghi)perylene	9.30E+02	4.74E-03	0.00E+00	0.00E+00	4.74E-03	0.00E+00	0.00E+00
Chrysene	2.20E+03	1.12E-02	0.00E+00	0.00E+00	1.12E-02	0.00E+00	0.00E+00
Dibenz(a,h)anthracene	6.87E+02	3.50E-03	0.00E+00	0.00E+00	3.50E-03	0.00E+00	0.00E+00
Dibenzofuran	0.00E+00	0.00E+00	0.00E+00	0.00E+00	0.00E+00	0.00E+00	0.00E+00
1,2-Dichlorobenzene	0.00E+00	0.00E+00	0.00E+00	0.00E+00	0.00E+00	0.00E+00	0.00E+00
Fluoranthene	3.80E+03	1.94E-02	0.00E+00	0.00E+00	1.94E-02	0.00E+00	0.00E+00
Fluorene	0.00E+00	0.00E+00	0.00E+00	0.00E+00	0.00E+00	0.00E+00	0.00E+00
Hexachlorobenzene	0.00E+00	0.00E+00	0.00E+00	0.00E+00	0.00E+00	0.00E+00	0.00E+00
Indeno(1,2,3-cd)pyrene	1.02E+03	5.19E-03	0.00E+00	0.00E+00	5.19E-03	0.00E+00	0.00E+00
2-Methylnaphthalene	0.00E+00	0.00E+00	0.00E+00	0.00E+00	0.00E+00	0.00E+00	0.00E+00
Naphthalene	0.00E+00	0.00E+00	0.00E+00	0.00E+00	0.00E+00	0.00E+00	0.00E+00
Nitrobenzene	0.00E+00	0.00E+00	0.00E+00	0.00E+00	0.00E+00	0.00E+00	0.00E+00
Phenanthrene	1.18E+03	6.04E-03	0.00E+00	0.00E+00	6.04E-03	0.00E+00	0.00E+00
Pyrene	2.77E+03	1.41E-02	8.73E+00	2.41E-04	1.44E-02	0.00E+00	0.00E+00
Pesticides	µg/kg	lbs	µg/L	lbs	lbs	µg/L	lbs
4,4'-DDE	0.00E+00	0.00E+00	0.00E+00	0.00E+00	0.00E+00	0.00E+00	0.00E+00
4,4'-DDD	0.00E+00	0.00E+00	0.00E+00	0.00E+00	0.00E+00	0.00E+00	0.00E+00
4,4'-DDT	0.00E+00	0.00E+00	0.00E+00	0.00E+00	0.00E+00	0.00E+00	0.00E+00
PCB Aroclors	µg/kg	lbs	µg/L	lbs	lbs	µg/L	lbs
A 1254	3.80E+02	1.94E-03	0.00E+00	0.00E+00	1.94E-03	0.00E+00	0.00E+00
A1260	1.59E+02	8.10E-04	0.00E+00	0.00E+00	8.10E-04	0.00E+00	0.00E+00
PCB Congeners	pg/g	lbs	pg/L	lbs	lbs	pg/L	lbs
Furans	pg/g	lbs	pg/L	lbs	lbs	pg/L	lbs
TCDFs (total)	0.00E+00	0.00E+00	0.00E+00	0.00E+00	0.00E+00	0.00E+00	0.00E+00
2,3,7,8-TCDF	0.00E+00	0.00E+00	0.00E+00	0.00E+00	0.00E+00	0.00E+00	0.00E+00
Dioxins	pg/g	lbs	pg/L	lbs	lbs	pg/L	lbs
TCDDs (total)	0.00E+00	0.00E+00	0.00E+00	0.00E+00	0.00E+00	0.00E+00	0.00E+00
2,3,7,8-TCDD	0.00E+00	0.00E+00	0.00E+00	0.00E+00	0.00E+00	0.00E+00	0.00E+00
TEQ (Calculated)	0.00E+00	0.00E+00	0.00E+00	0.00E+00	0.00E+00	0.00E+00	0.00E+00
Totals by class							
Total Metals					4.54E+00		3.11E-05
Total PAHs					9.90E-02		0.00E+00
Total PCBs (Aroclors)					2.75E-03		0.00E+00
Total PCBs (Homologues)					0.00E+00		1.65E-06
Total Dioxins/Furans					0.00E+00		0.00E+00

Appendix E. BiogenesisSM Mass Balance--NY/NJ Harbor Demonstration (1999)

Process Stream	Oxidation/Cavitation Outlet (OXO) (Hydrocyclone-Centrifuge Inlet)				
Stream Number	7				
Total Mass Input, lbs	32,847				
Total Solids Concentration, %	0				
Mass Dry Weight Solids, lbs	5,102				
Mass Water, lbs	27,745				
Source of Mass					
Source of Solids Concentration					
Source of Chemical Data					
Other Notes					
	Solids		Liquids		Total
	Conc.	Mass	Conc.	Mass	Mass
	mg/kg	lbs	µg/L	lbs	lbs
METALS					
Antimony	0.00E+00	0.00E+00	3.34E+01	9.27E-04	9.27E-04
Arsenic	1.03E+01	5.27E-02	8.40E+01	2.33E-03	5.51E-02
Beryllium	6.97E-01	3.55E-03	4.37E+00	1.21E-04	3.68E-03
Cadmium	1.77E+00	9.01E-03	1.36E+02	3.76E-03	1.28E-02
Chromium	1.06E+02	5.40E-01	1.36E+03	3.77E-02	5.78E-01
Copper	9.67E+01	4.93E-01	4.83E+03	1.34E-01	6.27E-01
Lead	1.02E+02	5.20E-01	1.84E+03	5.11E-02	5.71E-01
Nickel	3.18E+01	1.62E-01	4.54E+02	1.26E-02	1.75E-01
Selenium	6.37E-01	3.25E-03	1.76E+01	4.88E-04	3.74E-03
Silver	2.07E+00	1.05E-02	1.98E+01	5.48E-04	1.11E-02
Thallium	2.13E-01	1.09E-03	1.70E+00	4.72E-05	1.14E-03
Zinc	1.79E+02	9.12E-01	1.02E+04	2.82E-01	1.19E+00
Mercury	2.13E+00	1.09E-02	2.89E+01	8.01E-04	1.17E-02
PAHs	µg/kg	lbs	µg/L	lbs	lbs
Acenaphthene	0.00E+00	0.00E+00	0.00E+00	0.00E+00	0.00E+00
Acenaphthylene	0.00E+00	0.00E+00	0.00E+00	0.00E+00	0.00E+00
Anthracene	0.00E+00	0.00E+00	0.00E+00	0.00E+00	0.00E+00
Benzo(a)anthracene	1.77E+03	9.01E-03	0.00E+00	0.00E+00	9.01E-03
Benzo(a)pyrene	1.77E+03	9.01E-03	0.00E+00	0.00E+00	9.01E-03
Benzo(b)fluoranthene	1.60E+03	8.15E-03	0.00E+00	0.00E+00	8.15E-03
Benzo(k)fluoranthene	1.32E+03	6.72E-03	0.00E+00	0.00E+00	6.72E-03
Benzo(ghi)perylene	9.53E+02	4.86E-03	0.00E+00	0.00E+00	4.86E-03
Chrysene	2.07E+03	1.05E-02	0.00E+00	0.00E+00	1.05E-02
Dibenz(a,h)anthracene	6.73E+02	3.44E-03	0.00E+00	0.00E+00	3.44E-03
Dibenzofuran	0.00E+00	0.00E+00	0.00E+00	0.00E+00	0.00E+00
1,2-Dichlorobenzene	0.00E+00	0.00E+00	0.00E+00	0.00E+00	0.00E+00
Fluoranthene	3.60E+03	1.84E-02	8.77E+00	2.43E-04	1.86E-02
Fluorene	0.00E+00	0.00E+00	0.00E+00	0.00E+00	0.00E+00
Hexachlorobenzene	0.00E+00	0.00E+00	0.00E+00	0.00E+00	0.00E+00
Indeno(1,2,3-cd)pyrene	9.77E+02	4.98E-03	0.00E+00	0.00E+00	4.98E-03
2-Methylnaphthalene	0.00E+00	0.00E+00	0.00E+00	0.00E+00	0.00E+00
Naphthalene	0.00E+00	0.00E+00	0.00E+00	0.00E+00	0.00E+00
Nitrobenzene	0.00E+00	0.00E+00	0.00E+00	0.00E+00	0.00E+00
Phenanthrene	1.25E+03	6.38E-03	5.73E+00	1.59E-04	6.54E-03
Pyrene	2.60E+03	1.33E-02	9.43E+00	2.62E-04	1.35E-02
Pesticides	µg/kg	lbs	µg/L	lbs	lbs
4,4'-DDE	0.00E+00	0.00E+00	0.00E+00	0.00E+00	0.00E+00
4,4'-DDD	0.00E+00	0.00E+00	0.00E+00	0.00E+00	0.00E+00
4,4'-DDT	0.00E+00	0.00E+00	0.00E+00	0.00E+00	0.00E+00
PCB Aroclors	µg/kg	lbs	µg/L	lbs	lbs
A 1254	3.47E+02	1.77E-03	0.00E+00	0.00E+00	1.77E-03
A1260	1.87E+02	9.52E-04	0.00E+00	0.00E+00	9.52E-04
PCB Congeners	pg/g	lbs	pg/L	lbs	lbs
Furans	pg/g	lbs	pg/L	lbs	lbs
TCDFs (total)	0.00E+00	0.00E+00	0.00E+00	0.00E+00	0.00E+00
2,3,7,8-TCDF	0.00E+00	0.00E+00	0.00E+00	0.00E+00	0.00E+00
Dioxins	pg/g	lbs	pg/L	lbs	lbs
TCDDs (total)	0.00E+00	0.00E+00	0.00E+00	0.00E+00	0.00E+00
2,3,7,8-TCDD	0.00E+00	0.00E+00	0.00E+00	0.00E+00	0.00E+00
TEQ (Calculated)	0.00E+00	0.00E+00	0.00E+00	0.00E+00	0.00E+00
Totals by class					
Total Metals					3.24E+00
Total PAHs					9.54E-02
Total PCBs (Aroclors)					2.72E-03
Total PCBs (Homologues)					0.00E+00
Total Dioxins/Furans					0.00E+00

Appendix E. BiogenesisSM Mass Balance--NY/NJ Harbor Demonstration (1999)

Process Stream	Centrifuge Cake (PSD)				
Stream Number	8				
Total Mass Input, lbs	5,007				
Total Solids Concentration, %	69.0%				
Mass Dry Weight Solids, lbs	3,455				
Mass Water, lbs	1,552				
Source of Mass					
Source of Solids Concentration					
Source of Chemical Data					
Other Notes					
	Solids		Liquids		Total
	Conc.	Mass	Conc.	Mass	Mass
	mg/kg	lbs	µg/L	lbs	lbs
METALS					
Antimony	8.07E-02	2.79E-04	0.00E+00	0.00E+00	2.79E-04
Arsenic	7.83E+00	2.71E-02	0.00E+00	0.00E+00	2.71E-02
Beryllium	4.10E-01	1.42E-03	0.00E+00	0.00E+00	1.42E-03
Cadmium	1.23E+00	4.26E-03	0.00E+00	0.00E+00	4.26E-03
Chromium	4.95E+01	1.71E-01	0.00E+00	0.00E+00	1.71E-01
Copper	5.66E+01	1.96E-01	0.00E+00	0.00E+00	1.96E-01
Lead	6.79E+01	2.35E-01	0.00E+00	0.00E+00	2.35E-01
Nickel	2.46E+01	8.50E-02	0.00E+00	0.00E+00	8.50E-02
Selenium	4.73E-01	1.64E-03	0.00E+00	0.00E+00	1.64E-03
Silver	9.30E-01	3.21E-03	0.00E+00	0.00E+00	3.21E-03
Thallium	1.93E-01	6.68E-04	0.00E+00	0.00E+00	6.68E-04
Zinc	1.31E+02	4.51E-01	0.00E+00	0.00E+00	4.51E-01
Mercury	2.97E-01	1.02E-03	0.00E+00	0.00E+00	1.02E-03
PAHs					
Acenaphthene	0.00E+00	0.00E+00	0.00E+00	0.00E+00	0.00E+00
Acenaphthylene	0.00E+00	0.00E+00	0.00E+00	0.00E+00	0.00E+00
Anthracene	0.00E+00	0.00E+00	0.00E+00	0.00E+00	0.00E+00
Benzo(a)anthracene	1.60E+03	5.53E-03	0.00E+00	0.00E+00	5.53E-03
Benzo(a)pyrene	1.63E+03	5.64E-03	0.00E+00	0.00E+00	5.64E-03
Benzo(b)fluoranthene	1.40E+03	4.84E-03	0.00E+00	0.00E+00	4.84E-03
Benzo(k)fluoranthene	1.27E+03	4.38E-03	0.00E+00	0.00E+00	4.38E-03
Benzo(ghi)perylene	9.27E+02	3.20E-03	0.00E+00	0.00E+00	3.20E-03
Chrysene	1.77E+03	6.10E-03	0.00E+00	0.00E+00	6.10E-03
Dibenz(a,h)anthracene	4.67E+02	1.61E-03	0.00E+00	0.00E+00	1.61E-03
Dibenzofuran	0.00E+00	0.00E+00	0.00E+00	0.00E+00	0.00E+00
1,2-Dichlorobenzene	0.00E+00	0.00E+00	0.00E+00	0.00E+00	0.00E+00
Fluoranthene	2.93E+03	1.01E-02	0.00E+00	0.00E+00	1.01E-02
Fluorene	0.00E+00	0.00E+00	0.00E+00	0.00E+00	0.00E+00
Hexachlorobenzene	0.00E+00	0.00E+00	0.00E+00	0.00E+00	0.00E+00
Indeno(1,2,3-cd)pyrene	9.77E+02	3.37E-03	0.00E+00	0.00E+00	3.37E-03
2-Methylnaphthalene	0.00E+00	0.00E+00	0.00E+00	0.00E+00	0.00E+00
Naphthalene	0.00E+00	0.00E+00	0.00E+00	0.00E+00	0.00E+00
Nitrobenzene	0.00E+00	0.00E+00	0.00E+00	0.00E+00	0.00E+00
Phenanthrene	1.17E+03	4.03E-03	0.00E+00	0.00E+00	4.03E-03
Pyrene	2.40E+03	8.29E-03	0.00E+00	0.00E+00	8.29E-03
Pesticides					
4,4'-DDE	2.03E+01	7.03E-05	0.00E+00	0.00E+00	7.03E-05
4,4'-DDD	1.57E+01	5.41E-05	0.00E+00	0.00E+00	5.41E-05
4,4'-DDT	1.07E+01	3.70E-05	0.00E+00	0.00E+00	3.70E-05
PCB Aroclors					
A 1254	1.93E+02	6.68E-04	0.00E+00	0.00E+00	6.68E-04
A1260	0.00E+00	0.00E+00	0.00E+00	0.00E+00	0.00E+00
PCB Congeners					
Furans					
TCDFs (total)	2.07E+02	7.14E-07	0.00E+00	0.00E+00	7.14E-07
2,3,7,8-TCDF	9.43E+00	3.26E-08	0.00E+00	0.00E+00	3.26E-08
Dioxins					
TCDDs (total)	7.67E+01	2.65E-07	0.00E+00	0.00E+00	2.65E-07
2,3,7,8-TCDD	5.67E+01	1.96E-07	0.00E+00	0.00E+00	1.96E-07
TEQ (Calculated)	8.27E+01	2.86E-07	0.00E+00	0.00E+00	2.86E-07
Totals by class					
Total Metals					1.18E+00
Total PAHs					5.71E-02
Total PCBs (Aroclors)					6.68E-04
Total PCBs (Homologues)					7.59E-04
Total Dioxins/Furans					9.37E-06

Appendix E. BiogenesisSM Mass Balance--NY/NJ Harbor Demonstration (1999)

Process Stream	Centrifuge Liquids (PAQ)				
Stream Number	9				
Total Mass Input, lbs	27,839				
Total Solids Concentration, %	5.92%				
Mass Dry Weight Solids, lbs	1,647				
Mass Water, lbs	26,192				
Source of Mass					
Source of Solids Concentration					
Source of Chemical Data					
Other Notes					
	Solids		Liquids		Total
	Conc.	Mass	Conc.	Mass	Mass
	mg/kg	lbs	µg/L	lbs	lbs
METALS					
Antimony	9.13E-02	1.50E-04	4.46E+01	1.17E-03	1.32E-03
Arsenic	2.42E+01	3.98E-02	9.15E+01	2.40E-03	4.22E-02
Beryllium	1.73E+00	2.85E-03	4.53E+00	1.19E-04	2.97E-03
Cadmium	5.13E+00	8.45E-03	1.42E+02	3.71E-03	1.22E-02
Chromium	3.96E+02	6.53E-01	1.28E+03	3.36E-02	6.86E-01
Copper	3.33E+02	5.49E-01	4.02E+03	1.05E-01	6.54E-01
Lead	3.46E+02	5.70E-01	1.77E+03	4.64E-02	6.16E-01
Nickel	5.96E+01	9.82E-02	4.52E+02	1.18E-02	1.10E-01
Selenium	1.83E+00	3.02E-03	1.16E+01	3.03E-04	3.32E-03
Silver	8.47E+00	1.39E-02	2.49E+01	6.51E-04	1.46E-02
Thallium	3.47E-01	5.71E-04	1.50E+00	3.93E-05	6.10E-04
Zinc	3.09E+02	5.08E-01	1.01E+04	2.63E-01	7.72E-01
Mercury	7.03E+00	1.16E-02	2.86E+01	7.50E-04	1.23E-02
PAHs	µg/kg	lbs	µg/L	lbs	lbs
Acenaphthene	0.00E+00	0.00E+00	0.00E+00	0.00E+00	0.00E+00
Acenaphthylene	0.00E+00	0.00E+00	0.00E+00	0.00E+00	0.00E+00
Anthracene	0.00E+00	0.00E+00	4.50E+00	1.18E-04	1.18E-04
Benzo(a)anthracene	1.43E+03	2.36E-03	0.00E+00	0.00E+00	2.36E-03
Benzo(a)pyrene	0.00E+00	0.00E+00	0.00E+00	0.00E+00	0.00E+00
Benzo(b)fluoranthene	0.00E+00	0.00E+00	0.00E+00	0.00E+00	0.00E+00
Benzo(k)fluoranthene	0.00E+00	0.00E+00	0.00E+00	0.00E+00	0.00E+00
Benzo(ghi)perylene	0.00E+00	0.00E+00	0.00E+00	0.00E+00	0.00E+00
Chrysene	0.00E+00	0.00E+00	0.00E+00	0.00E+00	0.00E+00
Dibenz(a,h)anthracene	0.00E+00	0.00E+00	0.00E+00	0.00E+00	0.00E+00
Dibenzofuran	0.00E+00	0.00E+00	0.00E+00	0.00E+00	0.00E+00
1,2-Dichlorobenzene	0.00E+00	0.00E+00	0.00E+00	0.00E+00	0.00E+00
Fluoranthene	3.67E+03	6.04E-03	3.73E+00	9.78E-05	6.14E-03
Fluorene	0.00E+00	0.00E+00	0.00E+00	0.00E+00	0.00E+00
Hexachlorobenzene	0.00E+00	0.00E+00	0.00E+00	0.00E+00	0.00E+00
Indeno(1,2,3-cd)pyrene	0.00E+00	0.00E+00	0.00E+00	0.00E+00	0.00E+00
2-Methylnaphthalene	0.00E+00	0.00E+00	0.00E+00	0.00E+00	0.00E+00
Naphthalene	0.00E+00	0.00E+00	0.00E+00	0.00E+00	0.00E+00
Nitrobenzene	0.00E+00	0.00E+00	0.00E+00	0.00E+00	0.00E+00
Phenanthrene	0.00E+00	0.00E+00	0.00E+00	0.00E+00	0.00E+00
Pyrene	0.00E+00	0.00E+00	2.03E+00	5.33E-05	5.33E-05
Pesticides	µg/kg	lbs	µg/L	lbs	lbs
4,4'-DDE	9.00E+01	1.48E-04	0.00E+00	0.00E+00	1.48E-04
4,4'-DDD	3.98E+01	6.56E-05	0.00E+00	0.00E+00	6.56E-05
4,4'-DDT	0.00E+00	0.00E+00	0.00E+00	0.00E+00	0.00E+00
PCB Aroclors	µg/kg	lbs	µg/L	lbs	lbs
A 1254	9.17E+02	1.51E-03	0.00E+00	0.00E+00	1.51E-03
A1260	6.57E+02	1.08E-03	0.00E+00	0.00E+00	1.08E-03
PCB Congeners	pg/g	lbs	pg/L	lbs	lbs
Furans	pg/g	lbs	pg/L	lbs	lbs
TCDFs (total)	3.67E+02	6.04E-07	3.02E+03	7.92E-05	7.98E-05
2,3,7,8-TCDF	1.70E+01	2.80E-08	1.21E+02	3.16E-06	3.19E-06
Dioxins	pg/g	lbs	pg/L	lbs	lbs
TCDDs (total)	1.20E+02	1.98E-07	9.67E+02	2.53E-05	2.55E-05
2,3,7,8-TCDD	8.20E+01	1.35E-07	6.04E+02	1.58E-05	1.59E-05
TEQ (Calculated)	1.19E+02	1.97E-07	9.35E+02	2.45E-05	2.47E-05
Totals by class					
Total Metals		2.46E+00		4.70E-01	2.93E+00
Total PAHs		8.40E-03		2.69E-04	8.67E-03
Total PCBs (Aroclors)		2.59E-03		0.00E+00	2.59E-03
Total PCBs (Homologues)		8.17E-04		1.64E-01	1.65E-01
Total Dioxins/Furans		8.53E-06		1.42E-03	1.43E-03

Appendix E. BiogenesisSM Mass Balance--NY/NJ Harbor Demonstration (1999)

Process Stream	Total Input		Total Output			Overall Efficiency
Stream Number						
Total Mass Input, lbs	32,847		32,846			
Total Solids Concentration, %						
Mass Dry Weight Solids, lbs	5,102		5,102			
Mass Water, lbs	27,745		27,744			
Source of Mass						
Source of Solids Concentration						
Source of Chemical Data						
Other Notes						
	Total Input		Total Output		Mass Out/ Mass In	
	Mass lbs	Mass mg	Mass lbs	Mass mg		
METALS						
Antimony	6.77E-04	3.07E+02	1.60E-03	7.24E+02	2.36	-136%
Arsenic	6.85E-02	3.11E+04	6.93E-02	3.14E+04	1.01	-1.1%
Beryllium	4.78E-03	2.17E+03	4.39E-03	1.99E+03	0.92	8.2%
Cadmium	1.78E-02	8.09E+03	1.64E-02	7.45E+03	0.92	7.9%
Chromium	9.67E-01	4.39E+05	8.57E-01	3.89E+05	0.89	11.3%
Copper	9.47E-01	4.29E+05	8.50E-01	3.86E+05	0.90	10.2%
Lead	8.93E-01	4.05E+05	8.51E-01	3.86E+05	0.95	4.7%
Nickel	1.80E-01	8.18E+04	1.95E-01	8.85E+04	1.08	-8.2%
Selenium	5.27E-03	2.39E+03	4.96E-03	2.25E+03	0.94	5.9%
Silver	1.95E-02	8.83E+03	1.78E-02	8.08E+03	0.92	8.5%
Thallium	1.13E-03	5.12E+02	1.28E-03	5.80E+02	1.13	-13.2%
Zinc	1.58E+00	7.16E+05	1.22E+00	5.55E+05	0.77	22.5%
Mercury	2.22E-02	1.01E+04	1.34E-02	6.06E+03	0.60	39.8%
PAHs						
Acenaphthene	5.76E-05	2.61E+01	0.00E+00	0.00E+00	-	100.0%
Acenaphthylene	0.00E+00	0.00E+00	0.00E+00	0.00E+00		
Anthracene	7.53E-03	3.41E+03	1.18E-04	5.35E+01	0.02	98.4%
Benzo(a)anthracene	1.25E-02	5.66E+03	7.89E-03	3.58E+03	0.63	36.8%
Benzo(a)pyrene	1.24E-02	5.63E+03	5.64E-03	2.56E+03	0.45	54.5%
Benzo(b)fluoranthene	1.09E-02	4.96E+03	4.84E-03	2.19E+03	0.44	55.8%
Benzo(k)fluoranthene	8.73E-03	3.96E+03	4.38E-03	1.98E+03	0.50	49.9%
Benzo(ghi)perylene	7.86E-03	3.57E+03	3.20E-03	1.45E+03	0.41	59.3%
Chrysene	1.42E-02	6.43E+03	6.10E-03	2.77E+03	0.43	56.9%
Dibenz(a,h)anthracene	3.23E-03	1.47E+03	1.61E-03	7.31E+02	0.50	50.1%
Dibenzofuran	0.00E+00	0.00E+00	0.00E+00	0.00E+00		
1,2-Dichlorobenzene	0.00E+00	0.00E+00	0.00E+00	0.00E+00		
Fluoranthene	3.32E-02	1.51E+04	1.63E-02	7.38E+03	0.49	51.0%
Fluorene	5.62E-05	2.55E+01	0.00E+00	0.00E+00	-	100.0%
Hexachlorobenzene	0.00E+00	0.00E+00	0.00E+00	0.00E+00		
Indeno(1,2,3-cd)pyrene	8.57E-03	3.89E+03	3.37E-03	1.53E+03	0.39	60.6%
2-Methylnaphthalene	0.00E+00	0.00E+00	0.00E+00	0.00E+00		
Naphthalene	6.20E-05	2.81E+01	0.00E+00	0.00E+00	-	100.0%
Nitrobenzene	0.00E+00	0.00E+00	0.00E+00	0.00E+00		
Phenanthrene	2.66E-02	1.20E+04	4.03E-03	1.83E+03	0.15	84.8%
Pyrene	2.35E-02	1.07E+04	8.35E-03	3.78E+03	0.35	64.5%
Pesticides						
4,4'-DDE	2.14E-04	9.72E+01	2.18E-04	9.91E+01	1.02	-2.0%
4,4'-DDD	1.30E-04	5.89E+01	1.20E-04	5.43E+01	0.92	7.8%
4,4'-DDT	6.45E-05	2.93E+01	3.70E-05	1.68E+01	0.57	42.7%
PCB Aroclors						
A 1254	1.56E-03	7.07E+02	2.18E-03	9.88E+02	1.40	-39.8%
A1260	1.09E-03	4.94E+02	1.08E-03	4.90E+02	0.99	0.6%
PCB Congeners						
Furans						
TCDFs (total)	3.62E-04	1.64E+02	8.05E-05	3.65E+01	0.22	77.7%
2,3,7,8-TCDF	1.34E-05	6.10E+00	3.23E-06	1.46E+00	0.24	76.0%
Dioxins						
TCDDs (total)	1.28E-04	5.81E+01	2.58E-05	1.17E+01	0.20	79.9%
2,3,7,8-TCDD	7.90E-05	3.58E+01	1.61E-05	7.32E+00	0.20	79.6%
TEQ (Calculated)	1.21E-04	5.49E+01	2.50E-05	1.13E+01	0.21	79.4%
Totals by class						
Total Metals	4.71E+00	2.13E+06	4.11E+00	1.86E+06	0.87	12.7%
Total PAHs	1.69E-01	7.68E+04	6.58E-02	2.98E+04	0.39	61.2%
Total PCBs (Aroclors)	2.65E-03	1.20E+03	3.26E-03	1.48E+03	1.23	-23.1%
Total PCBs (Homologues)	3.56E-01	1.61E+05	1.66E-01	7.52E+04	0.47	53.4%
Total Dioxins/Furans	6.82E-03	3.09E+03	1.44E-03	6.53E+02	0.21	78.9%

Appendix E. BiogenesisSM Mass Balance--NY/NJ Harbor Demonstration (1999)

Process Stream	% of Input PPO	% of Input CCO	% of Input OXO	% of Input C-Cake	% of Input Centrate	% of Output C-Cake	% of Output Centrate
Stream Number							
Total Mass Input, lbs							
Total Solids Concentration, %							
Mass Dry Weight Solids, lbs							
Mass Water, lbs							
Source of Mass							
Source of Solids Concentration							
Source of Chemical Data							
Other Notes							
METALS							
Antimony	46.0%	47.2%	136.8%	41.2%	194.7%	17.4%	82.6%
Arsenic	84.4%	97.8%	80.3%	39.5%	61.6%	39.1%	60.9%
Beryllium	79.6%	96.3%	76.9%	29.6%	62.2%	32.3%	67.7%
Cadmium	68.4%	101.6%	71.6%	23.9%	68.2%	25.9%	74.1%
Chromium	64.8%	94.9%	59.7%	17.7%	71.0%	19.9%	80.1%
Copper	58.8%	96.8%	66.2%	20.7%	69.1%	23.0%	77.0%
Lead	71.6%	94.2%	64.0%	26.3%	69.0%	27.6%	72.4%
Nickel	100.8%	116.4%	96.9%	47.1%	61.0%	43.6%	56.4%
Selenium	76.9%	95.5%	70.9%	31.0%	63.1%	33.0%	67.0%
Silver	56.7%	90.8%	57.0%	16.5%	75.0%	18.0%	82.0%
Thallium	112.0%	112.4%	100.6%	59.2%	54.1%	52.3%	47.7%
Zinc	75.3%	96.4%	75.6%	28.6%	48.9%	36.9%	63.1%
Mercury	71.1%	75.2%	52.7%	4.6%	55.6%	7.7%	92.3%
PAHs							
Acenaphthene	0.0%	0.0%	0.0%	0.0%	0.0%		
Acenaphthylene							
Anthracene	0.0%	0.0%	0.0%	0.0%	1.6%	0.0%	100.0%
Benzo(a)anthracene	66.8%	76.4%	72.3%	44.3%	18.9%	70.1%	29.9%
Benzo(a)pyrene	64.4%	79.5%	72.6%	45.5%	0.0%	100.0%	0.0%
Benzo(b)fluoranthene	59.1%	80.8%	74.5%	44.2%	0.0%	100.0%	0.0%
Benzo(k)fluoranthene	76.0%	73.1%	77.0%	50.1%	0.0%	100.0%	0.0%
Benzo(ghi)perylene	69.2%	60.4%	61.9%	40.7%	0.0%	100.0%	0.0%
Chrysene	64.8%	79.2%	74.4%	43.1%	0.0%	100.0%	0.0%
Dibenz(a,h)anthracene	47.9%	108.4%	106.3%	49.9%	0.0%	100.0%	0.0%
Dibenzofuran							
1,2-Dichlorobenzene							
Fluoranthene	47.9%	58.4%	56.0%	30.5%	18.5%	62.3%	37.7%
Fluorene	0.0%	0.0%	0.0%	0.0%	0.0%		
Hexachlorobenzene							
Indeno(1,2,3-cd)pyrene	60.3%	60.5%	58.1%	39.4%	0.0%	100.0%	0.0%
2-Methylnaphthalene							
Naphthalene	0.0%	0.0%	0.0%	0.0%	0.0%		
Nitrobenzene							
Phenanthrene	23.1%	22.7%	24.6%	15.2%	0.0%	100.0%	0.0%
Pyrene	51.1%	61.1%	57.5%	35.3%	0.2%	99.4%	0.6%
Pesticides							
4,4'-DDE	0.0%	0.0%	0.0%	32.8%	69.2%	32.2%	67.8%
4,4'-DDD	0.0%	0.0%	0.0%	41.7%	50.5%	45.2%	54.8%
4,4'-DDT	0.0%	0.0%	0.0%	57.3%	0.0%	100.0%	0.0%
PCB Aroclors							
A 1254	84.9%	124.4%	113.5%	42.9%	96.9%	30.7%	69.3%
A1260	34.8%	74.5%	87.5%	0.0%	99.4%	0.0%	100.0%
PCB Congeners							
Furans							
TCDFs (total)	0.0%	0.0%	0.0%	0.2%	22.1%	0.9%	99.1%
2,3,7,8-TCDF	0.0%	0.0%	0.0%	0.2%	23.7%	1.0%	99.0%
Dioxins							
TCDDs (total)	0.0%	0.0%	0.0%	0.2%	19.9%	1.0%	99.0%
2,3,7,8-TCDD	0.0%	0.0%	0.0%	0.2%	20.2%	1.2%	98.8%
TEQ (Calculated)	0.0%	0.0%	0.0%	0.2%	20.4%	1.1%	98.9%
Totals by class							
Total Metals	70.1%	96.4%	69.0%	25.0%	62.2%	28.7%	71.3%
Total PAHs	50.1%	58.5%	56.3%	33.7%	5.1%	86.8%	13.2%
Total PCBs (Aroclors)	64.3%	103.9%	102.8%	25.2%	97.9%	20.5%	79.5%
Total PCBs (Homologues)	0.0%	0.0%	0.0%	0.2%	46.4%	0.5%	99.5%
Total Dioxins/Furans	0.0%	0.0%	0.0%	0.1%	21.0%	0.7%	99.3%

Appendix E. Biogenesis™ Mass Balance--NY/NJ Harbor Demonstration (1999)

Process Stream	PPO Efficiency	CCO Efficiency	OXO Efficiency	Centri-fuge Efficiency	Decon-tamination Efficiency
Stream Number					
Total Mass Input, lbs					
Total Solids Concentration,%					
Mass Dry Weight Solids, lbs					
Mass Water, lbs					
Source of Mass					
Source of Solids Concentration					
Source of Chemical Data					
Other Notes					
METALS					
Antimony	54.0%	-2.7%	-189.8%	-72.4%	58.8%
Arsenic	15.6%	-15.8%	17.9%	-25.8%	60.5%
Beryllium	20.4%	-21.0%	20.1%	-19.4%	70.4%
Cadmium	31.6%	-48.6%	29.5%	-28.6%	76.1%
Chromium	35.2%	-46.3%	37.0%	-48.4%	82.3%
Copper	41.2%	-64.6%	31.5%	-35.5%	79.3%
Lead	28.4%	-31.5%	32.0%	-48.9%	73.7%
Nickel	-0.8%	-15.5%	16.8%	-11.7%	52.9%
Selenium	23.1%	-24.2%	25.8%	-32.7%	69.0%
Silver	43.3%	-60.0%	37.2%	-60.5%	83.5%
Thallium	-12.0%	-0.4%	10.5%	-12.6%	40.8%
Zinc	24.6%	-27.8%	21.6%	-2.5%	71.3%
Mercury	28.9%	-5.8%	30.0%	-14.3%	95.4%
PAHs					
Acenaphthene	100.0%				100.0%
Acenaphthylene					
Anthracene	100.0%				100.0%
Benzo(a)anthracene	33.2%	-14.3%	5.4%	12.5%	55.7%
Benzo(a)pyrene	35.6%	-23.4%	8.6%	37.4%	54.5%
Benzo(b)fluoranthene	40.9%	-36.8%	7.9%	40.6%	55.8%
Benzo(k)fluoranthene	24.0%	3.8%	-5.3%	34.9%	49.9%
Benzo(ghi)perylene	30.8%	12.8%	-2.5%	34.2%	59.3%
Chrysene	35.2%	-22.2%	6.1%	42.1%	56.9%
Dibenz(a,h)anthracene	52.1%	-126.4%	1.9%	53.1%	50.1%
Dibenzofuran					
1,2-Dichlorobenzene					
Fluoranthene	52.1%	-21.8%	4.0%	12.6%	69.5%
Fluorene	100.0%				100.0%
Hexachlorobenzene					
Indeno(1,2,3-cd)pyrene	39.7%	-0.3%	3.9%	32.3%	60.6%
2-Methylnaphthalene					
Naphthalene	100.0%				100.0%
Nitrobenzene					
Phenanthrene	76.9%	1.4%	-8.3%	38.3%	84.8%
Pyrene	48.9%	-19.4%	5.8%	38.3%	64.7%
Pesticides					
4,4'-DDE	100.0%				67.2%
4,4'-DDD	100.0%				58.3%
4,4'-DDT	100.0%				42.7%
PCB Aroclors					
A 1254	15.1%	-46.6%	8.8%	-23.1%	57.1%
A1260	65.2%	-113.7%	-17.5%	-13.6%	100.0%
PCB Congeners					
Furans					
TCDFs (total)	100.0%				99.8%
2,3,7,8-TCDF	100.0%				99.8%
Dioxins					
TCDDs (total)	100.0%				99.8%
2,3,7,8-TCDD	100.0%				99.8%
TEQ (Calculated)	100.0%				99.8%
Totals by class					
Total Metals	29.8%	-37.4%	28.5%	-26.5%	75.0%
Total PAHs	49.9%	-16.8%	3.7%	31.0%	66.3%
Total PCBs (Aroclors)	35.7%	-61.6%	1.0%	-19.8%	74.8%
Total PCBs (Homologues)	100.0%	100.0%	100.0%		99.8%
Total Dioxins/Furans	100.0%				99.9%

Appendix F: BioGenesisSM VENICE DEMONSTRATION MASS BALANCE MASS BALANCE

The enclosed tables support mass balance calculations reflected in the following:

- Chapter 2
 - Tables 14 and 16
 - Figures 11 and 12
- Chapter 3
 - Tables 24-26
 - Figures 32, 37-43
- Chapter 6
 - Table 34
 - Figure 45

Appendix F: Biogenesis Mass Balance Venice Pilot Demonstration

Batch 1: PC4 - Molo Sali				
Process Stream	Raw Sediment solids to Pre-Processor	Process Water Addition to Pre-Processor	Cleaning Chemicals to Pre-Processor	Sediment t Char
Stream Number	1	2		
Units	LBS	LBS	LBS	LE
Total Mass Input	78,041	57,783		135,
Percent Moisture	69.2%	100%		82.
Dry Weight Solids	24,037	0		24,1
Water	54,005	57,783		111,
Source of Mass	Appendix K		The flow rates of water in these streams are not specified in the report table 2-1 suggests they should be equal and Appendix K gives the streams.	
Source of Moisture Content	Appendix K			
Source of Chemical Info	Appendix K			
Other notes				
	Conc mg/kg	Mass lb		
Metals				
Arsenic	24.5	0.589		
Cadmium	7.30	0.175		
Chromium (total)	32.8	0.788		
Copper	94.7	2.28		
Lead	87.4	2.10		
Mercury	3.20	0.0769		
Nickel	14.8	0.356		
Zinc	5.31E+02	12.8		
Total Metals (Sum of Individual Metals)		19.1		
Polyaromatic Hydrocarbons (PAHs)				
Naphthalene	1.43	0.0344		
Acenaphthylene	0.350	0.00841		
Acenaphthene	0.260	0.00625		
Fluorene	0.280	0.00673		
Phenanthrene	0.870	0.0209		
Anthracene	0.480	0.0115		
Fluoranthene	3.30	0.0793		
Pyrene	3.05	0.0733		
Benz(a)anthracene	1.45	0.0349		
Chrysene	1.32	0.0317		
Benzo(b)fluoranthene	0.450	0.0108		
Benzo(k)fluoranthene	0.320	0.00769		
Benzo(a)pyrene	1.09	0.0262		
Indeno(1,2,3-cd)pyrene	0.640	0.0154		
Dibenz(a,h)anthracene	0.280	0.00673		
Benzo(g,h,i)perylene	0.750	0.0180		
Total (as reported)	16.3	0.392		
Total (Sum of Individual Compounds)		0.392		
Total Hydrocarbons				
Light Hydrocarbons (C < 12)	0	0		
Heavy Hydrocarbons (C > 12)	5.50E+02	13.2		
Total	5.50E+02	13.2		

Appendix F: Biogenesis Mass Balance Venice Pilot Demonstration

Batch 1: PC4 - Molo Sali						
Process Stream	to Collision Chamber	Process Water Addition to Collision Chamber	Chemical Addition to Collision Chamber	Sediment from Collision Chamber to Hydrocyclone		
Stream Number				3		
Units	SS	LBS	LBS	LBS		
Total Mass Input	825			135,825		
Percent Moisture	3%			82.3%		
Dry Weight Solids	037			24,037		
Water	788			111,788		
Source of Mass	ort, although	Appendix K		Calculated (1a+2a+1)		
Source of Moisture Content	total for the	Assumed		Calculated		
Source of Chemical Info		Assumed		Calculated		
Other notes		Assumed pure water				
		Conc µg/L	Mass lb		Conc mg/kg	Mass lb
Metals						
Arsenic		0	0		24.5	0.589
Cadmium		0	0		7.30	0.175
Chromium (total)		0	0		32.8	0.788
Copper		0	0		94.7	2.28
Lead		0	0		87.4	2.10
Mercury		0	0		3.20	0.0769
Nickel		0	0		14.8	0.356
Zinc		0	0		5.31E+02	12.8
Total Metals (Sum of Individual Metals)			0			19.1
Polyaromatic Hydrocarbons (PAHs)						
Naphthalene		0	0		1.43	0.0344
Acenaphthylene		0	0		0.350	0.00841
Acenaphthene		0	0		0.260	0.00625
Fluorene		0	0		0.280	0.00673
Phenanthrene		0	0		0.870	0.0209
Anthracene		0	0		0.480	0.0115
Fluoranthene		0	0		3.30	0.0793
Pyrene		0	0		3.05	0.0733
Benz(a)anthracene		0	0		1.45	0.0349
Chrysene		0	0		1.32	0.0317
Benzo(b)fluoranthene		0	0		0.450	0.0108
Benzo(k)fluoranthene		0	0		0.320	0.00769
Benzo(a)pyrene		0	0		1.09	0.0262
Indeno(1,2,3-cd)pyrene		0	0		0.640	0.0154
Dibenz(a,h)anthracene		0	0		0.280	0.00673
Benzo(g,h,i)perylene		0	0		0.750	0.0180
Total (as reported)		0	0		16.3	0.392
Total (Sum of Individual Compounds)			0			0.392
Total Hydrocarbons						
Light Hydrocarbons (C < 12)		0	0		0	0
Heavy Hydrocarbons (C > 12)		0	0		5.50E+02	13.2
Total		0	0		5.50E+02	13.2

Appendix F: Biogenesis Mass Balance Venice Pilot Demonstration

Batch 1: PC4 - Molo Sali							
Process Stream	Treated Sediment Removed by Hydrocyclone		Sediment to Cavitation/Oxidation Chamber		Sediment from Cavitation/Oxidation Chamber to Centrifuge		Cavitation Chamber Effluent Storage/
Stream Number	3r		4		5		LF
Units	LBS		LBS		LBS		
Total Mass Input	1,220		134,605		134,605		
Percent Moisture	21.0%		82.9%		82.9%		
Dry Weight Solids	964		23,073		23,073		
Water	256		111,532		111,532		
Source of Mass	Solid Mass Calculations		Calculated		Calculated		
Source of Moisture Content	Measured (Table 4-2-5)		Calculated		Calculated		
Source of Chemical Info	Measured (Table 4-2-5)		Calculated		Calculated		
Other notes							
	Conc mg/kg	Mass lb	Conc mg/kg	Mass lb	Conc mg/kg	Mass lb	
Metals							
Arsenic	6.20	0.00598	25.3	0.583	25.3	0.583	
Cadmium	1.60	0.00154	7.54	0.174	7.54	0.174	
Chromium (total)	16.8	0.0162	33.5	0.772	33.5	0.772	
Copper	16.6	0.0160	98.0	2.26	98.0	2.26	
Lead	27.2	0.0262	89.9	2.07	89.9	2.07	
Mercury	0.800	0.000771	3.30	0.0761	3.30	0.0761	
Nickel	5.40	0.00520	15.2	0.351	15.2	0.351	
Zinc	3.22E+02	0.310	5.40E+02	12.5	5.40E+02	12.5	
Total Metals (Sum of Individual Metals)		0.382		18.7		18.7	
Polyaromatic Hydrocarbons (PAHs)							
Naphthalene	0.630	0.000607	1.46	0.0338	1.46	0.0338	
Acenaphthylene	0.0400	0.0000386	0.363	0.00837	0.363	0.00837	
Acenaphthene	0.0400	0.0000386	0.269	0.00621	0.269	0.00621	
Fluorene	0.0300	0.0000289	0.290	0.00670	0.290	0.00670	
Phenanthrene	0.160	0.000154	0.900	0.0208	0.900	0.0208	
Anthracene	0.0600	0.0000578	0.498	0.0115	0.498	0.0115	
Fluoranthene	0.410	0.000395	3.42	0.0789	3.42	0.0789	
Pyrene	0.340	0.000328	3.16	0.0730	3.16	0.0730	
Benz(a)anthracene	0.280	0.000270	1.50	0.0346	1.50	0.0346	
Chrysene	0.190	0.000183	1.37	0.0315	1.37	0.0315	
Benzo(b)fluoranthene	0.0500	0.0000482	0.467	0.0108	0.467	0.0108	
Benzo(k)fluoranthene	0.0600	0.0000578	0.331	0.00763	0.331	0.00763	
Benzo(a)pyrene	0.150	0.000145	1.13	0.0261	1.13	0.0261	
Indeno(1,2,3-cd)pyrene	0.0900	0.0000867	0.663	0.0153	0.663	0.0153	
Dibenz(a,h)anthracene	0.0300	0.0000289	0.290	0.00670	0.290	0.00670	
Benzo(g,h,i)perylene	0.0900	0.0000867	0.778	0.0179	0.778	0.0179	
Total (as reported)	2.65	0.00255	16.9	0.390	16.9	0.390	
Total (Sum of Individual Compounds)		0.00255		0.390		0.390	
Total Hydrocarbons							
Light Hydrocarbons (C < 12)	0	0	0	0	0	0	
Heavy Hydrocarbons (C > 12)	64.0	0.0617	5.70E+02	13.2	5.70E+02	13.2	
Total	64.0	0.0617	5.70E+02	13.2	5.70E+02	13.2	

Appendix F: Biogenesis Mass Balance Venice Pilot Demonstration

Batch 1: PC4 - Molo Sai						
Process Stream	Oxidation Water to t Water treatment	Effluent Water Storage/Treatment to Centrifuge	Centrifuge Solids		Centrifuge Centrate	
Stream Number			6		7	
Units	SS	LBS	LBS		LBS	
Total Mass Input			28,328		106,277	
Percent Moisture			25.9%		98.1%	
Dry Weight Solids			21,005		2,068	
Water			7,323		104,209	
Source of Mass			Solid Mass Calculations		Solid Mass Calculations	
Source of Moisture Content			Measured (Table 4-2-5)		Water Balance	
Source of Chemical Info			Measured (Table 4-2-5)		Appendix K	
Other notes						
			Conc	Mass	Conc	Mass
			mg/kg	lb	µg/L	lb
Metals						
Arsenic			12.8	0.269	2,510	0.262
Cadmium			3.75	0.0788	1,010	0.105
Chromium (total)			20.6	0.433	3,150	0.328
Copper			27.4	0.574	11,200	1.17
Lead			30.6	0.643	12,600	1.31
Mercury			1.30	0.0273	5.49E+02	0.0572
Nickel			17.2	0.361	1,480	0.154
Zinc			3.72E+02	7.80	62,700	6.53
Total Metals (Sum of Individual Metals)				10.2		9.92
Polyaromatic Hydrocarbons (PAHs)						
Naphthalene			0.600	0.0126	4.13	0.000430
Acenaphthylene			0.245	0.00515	2.86	0.000298
Acenaphthene			0.155	0.00326	3.60	0.000375
Fluorene			0.130	0.00273	2.06	0.000215
Phenanthrene			0.630	0.0132	9.88	0.00103
Anthracene			0.570	0.0120	4.79	0.000499
Fluoranthene			2.45	0.0515	46.5	0.00485
Pyrene			1.60	0.0335	33.8	0.00352
Benz(a)anthracene			1.01	0.0211	8.84	0.000921
Chrysene			1.41	0.0296	8.11	0.000845
Benzo(b)fluoranthene			0.685	0.0144	9.55	0.000995
Benzo(k)fluoranthene			0.800	0.0168	6.69	0.000697
Benzo(a)pyrene			0.655	0.0138	4.57	0.000476
Indeno(1,2,3-cd)pyrene			0.385	0.00809	0.850	0.0000886
Dibenz(a,h)anthracene			0.130	0.00273	0.250	0.0000261
Benzo(g,h,i)perylene			0.395	0.00830	1.05	0.000109
Total (as reported)			11.8	0.249	1.48E+02	0.0154
Total (Sum of Individual Compounds)				0.249		0.0154
Total Hydrocarbons						
Light Hydrocarbons (C < 12)			0	0	0	0
Heavy Hydrocarbons (C > 12)			2.44E+02	5.11	0	0
Total			2.44E+02	5.11	0	0

Appendix F: Biogenesis Mass Balance Venice Pilot Demonstration

Batch 1: PC4 - Molo Sali							
Process Stream	Centrifuge Centrate - Dissolved		Centrifuge Centrate - Solid Only		Hydrocyclone Stage Mass Balance		
	Conc µg/L	Mass lb	Conc mg/kg	Mass lb	LBS	PCT	PCT
Stream Number					Mass In	Mass Out	
Units	LBS		LBS		Sediment from Collision Chamber to Hydrocyclone	Treated Sediment Removed by Hydrocyclone	Sediment to Cavitation/Oxidation Chamber
Total Mass Input	104,209		2,068				
Percent Moisture	100%		0				
Dry Weight Solids			2,068				
Water	104,209						
Source of Mass	Water Balance		Solid Mass Calculations				
Source of Moisture Content	N/A		N/A				
Source of Chemical Info	Appendix K		Calculated				
Other notes							
	Conc µg/L	Mass lb	Conc mg/kg	Mass lb	LBS	PCT	PCT
Metals							
Arsenic	51.0	0.00531	1.24E+02	0.256	0.589	1.01%	99.0%
Cadmium	6.59E+02	0.0687	17.7	0.0366	0.175	0.879%	99.1%
Chromium (total)	85.0	0.00886	1.54E+02	0.319	0.788	2.05%	97.9%
Copper	72.0	0.00750	5.61E+02	1.16	2.28	0.703%	99.3%
Lead	10,400	1.08	1.11E+02	0.229	2.10	1.25%	98.8%
Mercury	26.0	0.00271	26.4	0.0545	0.0769	1.00%	99.0%
Nickel	1.98E+02	0.0206	64.6	0.134	0.356	1.46%	98.5%
Zinc	53,300	5.55	4.74E+02	0.980	12.8	2.43%	97.6%
Total Metals (Sum of Individual Metals)		6.75		3.17			
Polyaromatic Hydrocarbons (PAHs)							
Naphthalene	3.16	0.000329	0.0489	0.000101	0.0344	1.77%	98.2%
Acenaphthylene	0.0100	0.00000104	0.144	0.000297	0.00841	0.458%	99.5%
Acenaphthene	0.0700	0.00000729	0.178	0.000368	0.00625	0.617%	99.4%
Fluorene	0.0300	0.00000313	0.102	0.000212	0.00673	0.430%	99.6%
Phenanthrene	0.100	0.0000104	0.493	0.00102	0.0209	0.737%	99.3%
Anthracene	0.0600	0.00000625	0.238	0.000493	0.0115	0.501%	99.5%
Fluoranthene	0.260	0.0000271	2.33	0.00482	0.0793	0.498%	99.5%
Pyrene	0.220	0.0000229	1.69	0.00350	0.0733	0.447%	99.6%
Benz(a)anthracene	0.0700	0.00000729	0.442	0.000914	0.0349	0.774%	99.2%
Chrysene	0.0700	0.00000729	0.405	0.000838	0.0317	0.577%	99.4%
Benzo(b)fluoranthene	0.0400	0.00000417	0.479	0.000991	0.0108	0.446%	99.6%
Benzo(k)fluoranthene	0.0500	0.00000521	0.335	0.000692	0.00769	0.752%	99.2%
Benzo(a)pyrene	0	0	0.230	0.000476	0.0262	0.552%	99.4%
Indeno(1,2,3-cd)pyrene	0	0	0.0428	0.0000886	0.0154	0.564%	99.4%
Dibenz(a,h)anthracene	0	0	0.0126	0.0000261	0.00673	0.430%	99.6%
Benzo(g,h,i)perylene	0	0	0.0529	0.000109	0.0180	0.481%	99.5%
Total (as reported)	4.10	0.000427	7.23	0.0149	0.392	0.651%	99.3%
Total (Sum of Individual Compounds)		0.000431		0.0149	0.392		
Total Hydrocarbons							
Light Hydrocarbons (C < 12)					0		
Heavy Hydrocarbons (C > 12)					13.2	0.467%	99.5%
Total					13.2	0.467%	99.5%

Appendix F: Biogenesis Mass Balance Venice Pilot Demonstration

Batch 1: PC4 - Molo Sali					
Process Stream	Ice	Centrifuge Stage Mass Balance			
Stream Number		Mass In		Mass Out	
Units		Sediment from Cavitation/ Oxidation Chamber to Centrifuge	Effluent Water Storage/Treatment to Centrifuge	Centrifuge Solids	Centrifuge Centrate - Dissolved
Total Mass Input	Mass Un-accounted For				
Percent Moisture					
Dry Weight Solids					
Water					
Source of Mass					
Source of Moisture Content					
Source of Chemical Info					
Other notes					
	PCT	LBS	LBS	PCT	PCT
Metals					
Arsenic	0%	0.583	0	46.1%	0.912%
Cadmium	0%	0.174	0	45.3%	39.5%
Chromium (total)	0%	0.772	0	56.0%	1.15%
Copper	0%	2.26	0	25.4%	0.332%
Lead	0%	2.07	0	31.0%	52.2%
Mercury	0%	0.0761	0	35.9%	3.56%
Nickel	0%	0.351	0	103%	5.89%
Zinc	0%	12.5	0	62.7%	44.6%
Total Metals (Sum of Individual Metals)					
Polyaromatic Hydrocarbons (PAHs)					
Naphthalene	0%	0.0338	0	37.3%	0.975%
Acenaphthylene	0%	0.00837	0	61.5%	0.0124%
Acenaphthene	0%	0.00621	0	52.4%	0.117%
Fluorene	0%	0.00670	0	40.7%	0.0467%
Phenanthrene	0%	0.0208	0	63.8%	0.0502%
Anthracene	0%	0.0115	0	104%	0.0545%
Fluoranthene	0%	0.0789	0	65.2%	0.0343%
Pyrene	0%	0.0730	0	45.9%	0.0314%
Benz(a)anthracene	0%	0.0346	0	61.0%	0.0211%
Chrysene	0%	0.0315	0	93.9%	0.0231%
Benzo(b)fluoranthene	0%	0.0108	0	134%	0.0387%
Benzo(k)fluoranthene	0%	0.00763	0	220%	0.0683%
Benzo(a)pyrene	0%	0.0261	0	52.8%	0%
Indeno(1,2,3-cd)pyrene	0%	0.0153	0	52.9%	0%
Dibenz(a,h)anthracene	0%	0.00670	0	40.7%	0%
Benzo(g,h,i)perylene	0%	0.0179	0	46.2%	0%
Total (as reported)	0%	0.390	0	63.8%	0.110%
Total (Sum of Individual Compounds)					
Total Hydrocarbons					
Light Hydrocarbons (C < 12)		0	0		
Heavy Hydrocarbons (C > 12)	0	13.2	0	38.9%	0.0000%
Total	0%	13.2	0	38.9%	0%

Appendix F: Biogenesis Mass Balance Venice Pilot Demonstration

Batch 1: PC4 - Molo Sali					
Process Stream			Overall Efficiency		
Stream Number	Centrifuge Centrate - Solids Only	Mass Unaccounted For	Mass Inputs	Mass Outputs	Efficiency
Units					
Total Mass Input					
Percent Moisture					
Dry Weight Solids					
Water					
Source of Mass					
Source of Moisture Content					
Source of Chemical Info					
Other notes					
	PCT	PCT	LBS	LBS	PCT
Metals					
Arsenic	44.0%	9.01%	0.589	0.536	8.91%
Cadmium	21.0%	-6%	0.175	0.186	-6%
Chromium (total)	41.4%	1.46%	0.788	0.777	1.43%
Copper	51.3%	22.9%	2.28	1.76	22.8%
Lead	11.1%	5.73%	2.10	1.98	5.66%
Mercury	71.6%	-11%	0.0769	0.0853	-11%
Nickel	38.1%	-47%	0.356	0.521	-46%
Zinc	7.87%	-15%	12.8	14.6	-15%
Total Metals (Sum of Individual Metals)					
Polyaromatic Hydrocarbons (PAHs)					
Naphthalene	0.299%	61.4%	0.0344	0.0136	60.3%
Acenaphthylene	3.55%	35.0%	0.00841	0.00548	34.8%
Acenaphthene	5.92%	41.5%	0.00625	0.00367	41.3%
Fluorene	3.16%	56.0%	0.00673	0.00297	55.8%
Phenanthrene	4.91%	31.3%	0.0209	0.0144	31.1%
Anthracene	4.29%	-9%	0.0115	0.0125	-9%
Fluoranthene	6.11%	28.7%	0.0793	0.0567	28.5%
Pyrene	4.79%	49.3%	0.0733	0.0374	49.0%
Benz(a)anthracene	2.64%	36.3%	0.0349	0.0223	36.0%
Chrysene	2.66%	3.43%	0.0317	0.0306	3.41%
Benzo(b)fluoranthene	9.20%	-42.9%	0.0108	0.0154	-42.67%
Benzo(k)fluoranthene	9.06%	-129.3%	0.00769	0.0176	-128.3%
Benzo(a)pyrene	1.83%	45.4%	0.0262	0.0144	45.1%
Indeno(1,2,3-cd)pyrene	0.579%	46.6%	0.0154	0.00826	46.3%
Dibenz(a,h)anthracene	0.389%	58.9%	0.00673	0.00279	58.6%
Benzo(g,h,i)perylene	0.610%	53.1%	0.0180	0.00849	52.9%
Total (as reported)	3.83%	32.2%	0.392	0.267	32.0%
Total (Sum of Individual Compounds)			0.392		
Total Hydrocarbons					
Light Hydrocarbons (C < 12)			0	0	
Heavy Hydrocarbons (C > 12)	0	61.1%	13.2	5.18	60.8%
Total	0%	61.1%	13.2	5.18	60.8%

Appendix F: Biogenesis Mass Balance Venice Pilot Demonstration

Batch 1: PC4 - Molo Sali				
Process Stream	Decontamination Efficiency			
Stream Number	Raw Sediment Solids to Pre-Processor	Treated Sediment Removed by Hydrocyclone	Centrifuge Solids	Efficiency
Units				
Total Mass Input				
Percent Moisture				
Dry Weight Solids				
Water				
Source of Mass				
Source of Moisture Content				
Source of Chemical Info				
Other notes				
	LBS	LBS	LBS	PCT
Metals				
Arsenic	0.589	0.00598	0.269	53.3%
Cadmium	0.175	0.00154	0.0788	54.2%
Chromium (total)	0.788	0.0162	0.433	43.1%
Copper	2.28	0.0160	0.574	74.1%
Lead	2.10	0.0262	0.643	68.2%
Mercury	0.0769	0.000771	0.0273	63.5%
Nickel	0.356	0.00520	0.361	-3.0%
Zinc	12.8	0.310	7.80	36.4%
Total Metals (Sum of Individual Metals)				
Polyaromatic Hydrocarbons (PAHs)				
Naphthalene	0.0344	0.000607	0.0126	61.6%
Acenaphthylene	0.00841	0.000386	0.00515	38.4%
Acenaphthene	0.00625	0.000386	0.00326	47.3%
Fluorene	0.00673	0.000289	0.00273	59.0%
Phenanthrene	0.0209	0.000154	0.0132	36.0%
Anthracene	0.0115	0.0000578	0.0120	-4.3%
Fluoranthene	0.0793	0.000395	0.0515	34.6%
Pyrene	0.0733	0.000328	0.0335	53.9%
Benz(a)anthracene	0.0349	0.000270	0.0211	38.7%
Chrysene	0.0317	0.000183	0.0296	6.08%
Benzo(b)fluoranthene	0.0108	0.0000482	0.0144	-33.5%
Benzo(k)fluoranthene	0.00769	0.0000578	0.0168	-119.2%
Benzo(a)pyrene	0.0262	0.000145	0.0138	46.9%
Indeno(1,2,3-cd)pyrene	0.0154	0.0000867	0.00809	46.9%
Dibenz(a,h)anthracene	0.00673	0.0000289	0.00273	59.0%
Benzo(g,h,i)perylene	0.0180	0.0000867	0.00830	53.5%
Total (as reported)	0.392	0.00255	0.249	36.0%
Total (Sum of Individual Compounds)	0.392			
Total Hydrocarbons				
Light Hydrocarbons (C < 12)	0	0	0	
Heavy Hydrocarbons (C > 12)	13.2	0.0617	5.11	60.8%
Total	13.2	0.0617	5.11	60.8%

Appendix F: Biogenesis Mass Balance Venice Pilot Demonstration

Batch 2: PC2 CIO Lower Reach			
Process Stream	Raw Sediment Solids to Pre-Processor	Process Water Addition to Pre-Processor	Cleaning Chemicals to Pre-Processor
Stream Number	1	2	
Units	LBS	LBS	LBS
Total Mass Input	56,377	42,748	
Percent Moisture	73.7%	100%	
Dry Weight Solids	14,827	0	
Water	41,550	42,748	
Source of Mass	Appendix K	The flow rates of water in these streams are not specified in I suggests they should be equal and Appendix K gives th	
Source of Moisture Content	Appendix K		
Source of Chemical Info	Appendix K		
Other notes			
	Conc mg/kg	Mass lb	
Metals			
Arsenic	73.4	1.09	
Cadmium	5.60	0.0830	
Chromium (total)	57.4	0.851	
Copper	1.45E+02	2.15	
Lead	1.04E+02	1.54	
Mercury	6.20	0.0919	
Nickel	11.8	0.175	
Zinc	2.95E+02	4.37	
Total (Sum of Individual Metals)		10.4	
Polyaromatic Hydrocarbons (PAHs)			
Naphthalene	4.77	0.0707	
Acenaphthylene	0.210	0.00311	
Acenaphthene	0.190	0.00282	
Fluorene	0.150	0.00222	
Phenanthrene	1.03	0.0153	
Anthracene	0.360	0.00534	
Fluoranthene	3.55	0.0526	
Pyrene	3.18	0.0472	
Benz(a)anthracene	1.50	0.0222	
Chrysene	2.51	0.0372	
Benzo(b)fluoranthene	1.67	0.0248	
Benzo(k)fluoranthene	1.53	0.0227	
Benzo(a)pyrene	1.68	0.0249	
Indeno(1,2,3-cd)pyrene	0.930	0.0138	
Dibenz(a,h)anthracene	0.500	0.00741	
Benzo(g,h,i)perylene	1.51	0.0224	
Total (as reported)	25.3	0.375	
Total (Sum of Individual Compounds)		0.375	
Total Hydrocarbons			
Light Hydrocarbons (C < 12)	0	0	
Heavy Hydrocarbons (C > 12)	1,330	19.7	
Total	1,330	19.7	

Appendix F: Biogenesis Mass Balance Venice Pilot Demonstration

Batch 2: PC2 CIO Lower Reach					
Process Stream	Sediment to Collision Chamber	Process Water Addition to Collision Chamber	Chemical Addition to Collision Chamber		
Stream Number					
Units	LBS	LBS	LBS		
Total Mass Input	99,124				
Percent Moisture	85.0%				
Dry Weight Solids	14,827				
Water	84,297				
Source of Mass		Appendix K			
Source of Moisture Content	the report, although table 2-1	Assumed			
Source of Chemical Info	the total for the streams.	Assumed			
Other notes		Assumed pure water			
		Conc	Mass		
		µg/L	lb		
Metals					
Arsenic		0	0		
Cadmium		0	0		
Chromium (total)		0	0		
Copper		0	0		
Lead		0	0		
Mercury		0	0		
Nickel		0	0		
Zinc		0	0		
Total (Sum of Individual Metals)			0		
Polyaromatic Hydrocarbons (PAHs)					
Naphthalene		0	0		
Acenaphthylene		0	0		
Acenaphthene		0	0		
Fluorene		0	0		
Phenanthrene		0	0		
Anthracene		0	0		
Fluoranthene		0	0		
Pyrene		0	0		
Benz(a)anthracene		0	0		
Chrysene		0	0		
Benzo(b)fluoranthene		0	0		
Benzo(k)fluoranthene		0	0		
Benzo(a)pyrene		0	0		
Indeno(1,2,3-cd)pyrene		0	0		
Dibenz(a,h)anthracene		0	0		
Benzo(g,h,i)perylene		0	0		
Total (as reported)		0	0		
Total (Sum of Individual Compounds)			0		
Total Hydrocarbons					
Light Hydrocarbons (C < 12)		0	0		
Heavy Hydrocarbons (C > 12)		0	0		
Total		0	0		

Appendix F: Biogenesis Mass Balance Venice Pilot Demonstration

Batch 2: PC2 CIO Lower Reach						
Process Stream	Sediment from Collision Chamber to Hydrocyclone		Treated Sediment Removed by Hydrocyclone		Sediment to Cavitation/Oxidation Chamber	
Stream Number	3		3r		4	
Units	LBS		LBS		LBS	
Total Mass Input	99,124		651		98,473	
Percent Moisture	85.0%		21.2%		85.5%	
Dry Weight Solids	14,827		513		14,314	
Water	84,297		138		84,159	
Source of Mass	Calculated (1a+2a+1)		Solid Mass Calculations		Calculated	
Source of Moisture Content	Calculated		Measured (Table 4-2-5)		Calculated	
Source of Chemical Info	Calculated		Measured (Table 4-2-5)		Calculated	
Other notes						
	Conc	Mass	Conc	Mass	Conc	Mass
	mg/kg	lb	mg/kg	lb	mg/kg	lb
Metals						
Arsenic	73.4	1.09	11.3	0.00579	75.6	1.08
Cadmium	5.60	0.0830	1.07	0.000549	5.76	0.0825
Chromium (total)	57.4	0.851	11.5	0.00590	59.0	0.845
Copper	1.45E+02	2.15	28.8	0.0148	1.49E+02	2.14
Lead	1.04E+02	1.54	32.7	0.0168	1.07E+02	1.53
Mercury	6.20	0.0919	0.450	0.000231	6.41	0.0917
Nickel	11.8	0.175	3.60	0.00185	12.1	0.173
Zinc	2.95E+02	4.37	84.0	0.0431	3.03E+02	4.33
Total (Sum of Individual Metals)		10.4		0.0889		10.3
Polyaromatic Hydrocarbons (PAHs)						
Naphthalene	4.77	0.0707	0.600	0.000308	4.92	0.0704
Acenaphthylene	0.210	0.00311	0.0200	0.0000103	0.217	0.00310
Acenaphthene	0.190	0.00282	0.0200	0.0000103	0.196	0.00281
Fluorene	0.150	0.00222	0.0200	0.0000103	0.155	0.00221
Phenanthrene	1.03	0.0153	0.180	0.0000923	1.06	0.0152
Anthracene	0.360	0.00534	0.0600	0.0000308	0.371	0.00531
Fluoranthene	3.55	0.0526	0.480	0.000246	3.66	0.0524
Pyrene	3.18	0.0472	0.460	0.000236	3.28	0.0469
Benz(a)anthracene	1.50	0.0222	0.230	0.000118	1.55	0.0221
Chrysene	2.51	0.0372	0.320	0.000164	2.59	0.0371
Benzo(b)fluoranthene	1.67	0.0248	0.210	0.000108	1.72	0.0247
Benzo(k)fluoranthene	1.53	0.0227	0.170	0.0000872	1.58	0.0226
Benzo(a)pyrene	1.68	0.0249	0.200	0.000103	1.73	0.0248
Indeno(1,2,3-cd)pyrene	0.930	0.0138	0.120	0.0000615	0.959	0.0137
Dibenz(a,h)anthracene	0.500	0.00741	0.0500	0.0000256	0.516	0.00739
Benzo(g,h,i)perylene	1.51	0.0224	0.140	0.0000718	1.56	0.0223
Total (as reported)	25.3	0.375	3.28	0.00168	26.1	0.373
Total (Sum of Individual Compounds)		0.375		0.00168		0.373
Total Hydrocarbons						
Light Hydrocarbons (C < 12)	0	0	0	0	0	0
Heavy Hydrocarbons (C > 12)	1,330	19.7	1.70E+02	0.0872	1,372	19.6
Total	1,330	19.7	1.70E+02	0.0872	1,372	19.6

Appendix F: Biogenesis Mass Balance Venice Pilot Demonstration

Batch 2: PC2 CIO Lower Reach			
Process Stream	Sediment from Cavitation/ Oxidation Chamber to Centrifuge	Cavitation/Oxidation Chamber Water to Effluent Water Storage/Treatment	Effluent Water Storage/Treatment to Centrifuge
Stream Number	5		
Units	LBS	LBS	LBS
Total Mass Input	98,473		
Percent Moisture	85.5%		
Dry Weight Solids	14,314		
Water	84,159		
Source of Mass	Calculated		
Source of Moisture Content	Calculated		
Source of Chemical Info	Calculated		
Other notes			
	Conc mg/kg	Mass lb	
Metals			
Arsenic	75.6	1.08	
Cadmium	5.76	0.0825	
Chromium (total)	59.0	0.845	
Copper	1.49E+02	2.14	
Lead	1.07E+02	1.53	
Mercury	6.41	0.0917	
Nickel	12.1	0.173	
Zinc	3.03E+02	4.33	
Total (Sum of Individual Metals)		10.3	
Polyaromatic Hydrocarbons (PAHs)			
Naphthalene	4.92	0.0704	
Acenaphthylene	0.217	0.00310	
Acenaphthene	0.196	0.00281	
Fluorene	0.155	0.00221	
Phenanthrene	1.06	0.0152	
Anthracene	0.371	0.00531	
Fluoranthene	3.66	0.0524	
Pyrene	3.28	0.0469	
Benz(a)anthracene	1.55	0.0221	
Chrysene	2.59	0.0371	
Benzo(b)fluoranthene	1.72	0.0247	
Benzo(k)fluoranthene	1.58	0.0226	
Benzo(a)pyrene	1.73	0.0248	
Indeno(1,2,3-cd)pyrene	0.959	0.0137	
Dibenz(a,h)anthracene	0.516	0.00739	
Benzo(g,h,i)perylene	1.56	0.0223	
Total (as reported)	26.1	0.373	
Total (Sum of Individual Compounds)		0.373	
Total Hydrocarbons			
Light Hydrocarbons (C < 12)	0	0	
Heavy Hydrocarbons (C > 12)	1,372	19.6	
Total	1,372	19.6	

Appendix F: Biogenesis Mass Balance Venice Pilot Demonstration

Batch 2: PC2 CIO Lower Reach						
Process Stream	Centrifuge Solids		Centrifuge Centrate		Centrifuge Centrate - Dissolved	
Stream Number	6		7			
Units	LBS		LBS		LBS	
Total Mass Input	15,010		76,850		74,929	
Percent Moisture	28.9%		97.5%		100%	
Dry Weight Solids	10,672		1,921			
Water	4,338		74,929		74,929	
Source of Mass	Solid Mass Calculations		Solid Mass Calculations		Water Balance	
Source of Moisture Content	Measured (Table 4-2-5)		Water Balance		N/A	
Source of Chemical Info	Measured (Table 4-2-5)		Appendix K		Appendix K	
Other notes						
	Conc mg/kg	Mass lb	Conc µg/L	Mass lb	Conc µg/L	Mass lb
Metals						
Arsenic	34.4	0.367	8,080	0.605	37.0	0.00277
Cadmium	2.30	0.0245	8.30E+02	0.0622	98.0	0.00734
Chromium (total)	25.9	0.276	6,370	0.477	18.0	0.00135
Copper	60.4	0.645	15,000	1.12	53.0	0.00397
Lead	30.3	0.323	13,600	1.02	7,040	0.527
Mercury	3.00	0.0320	7.00E+02	0.0525	0	0
Nickel	7.00	0.0747	1,320	0.0989	2.06E+02	0.0154
Zinc	1.07E+02	1.14	59,500	4.46	21,200	1.59
Total (Sum of Individual Metals)		2.88		7.90		2.15
Polyaromatic Hydrocarbons (PAHs)						
Naphthalene	1.48	0.0158	14.3	0.00107	10.9	0.000817
Acenaphthylene	0.140	0.00149	1.06	0.0000794	0.0200	0.00000150
Acenaphthene	0.100	0.00107	1.61	0.000121	0.0700	0.00000525
Fluorene	0.100	0.00107	1.10	0.0000824	0.0400	0.00000300
Phenanthrene	1.13	0.0121	4.60	0.000345	0.0700	0.00000525
Anthracene	0.310	0.00331	1.79	0.000134	0.0200	0.00000150
Fluoranthene	2.60	0.0277	8.50	0.000637	0.0700	0.00000525
Pyrene	2.57	0.0274	12.2	0.000914	0.0800	0.00000599
Benzo(a)anthracene	1.06	0.0113	3.01	0.000226	0.0200	0.00000150
Chrysene	1.40	0.0149	3.20	0.000240	0.0200	0.00000150
Benzo(b)fluoranthene	1.27	0.0136	3.45	0.000259	0	0
Benzo(k)fluoranthene	1.20	0.0128	1.89	0.000142	0	0
Benzo(a)pyrene	1.38	0.0147	2.39	0.000179	0.0100	0.000000749
Indeno(1,2,3-cd)pyrene	0.720	0.00768	1.36	0.000102	0	0
Dibenz(a,h)anthracene	0.370	0.00395	0.410	0.0000307	0.0700	0.00000525
Benzo(g,h,i)perylene	1.16	0.0124	2.31	0.000173	0	0
Total (as reported)	17.0	0.181	63.2	0.00474	11.4	0.000854
Total (Sum of Individual Compounds)		0.181		0.00473		0.000853
Total Hydrocarbons						
Light Hydrocarbons (C < 12)	0	0	0	0		
Heavy Hydrocarbons (C > 12)	8.35E+02	8.91	0	0		
Total	8.35E+02	8.91	0	0		

Appendix F: Biogenesis Mass Balance Venice Pilot Demonstration

Batch 2: PC2 CIO Lower Reach						
Process Stream	Centrifuge Centrate - Solid Only		Hydrocyclone Stage Mass Balance			
	Stream Number		Mass In	Mass Out		Mass Unaccounted For
Units	LBS		Sediment from Collision Chamber to Hydrocyclone	Treated Sediment Removed by Hydrocyclone	Sediment to Cavitation/Oxidation Chamber	
Total Mass Input	1,921					
Percent Moisture	0					
Dry Weight Solids	1,921					
Water						
Source of Mass	Solid Mass Calculations					
Source of Moisture Content	N/A					
Source of Chemical Info	Calculated					
Other notes						
	Conc mg/kg	Mass lb	LBS	PCT	PCT	PCT
Metals						
Arsenic	3.17E+02	0.609	1.09	0.532%	99.5%	0%
Cadmium	28.8	0.0554	0.0830	0.661%	99.3%	0%
Chromium (total)	2.50E+02	0.481	0.851	0.693%	99.3%	0%
Copper	5.89E+02	1.13	2.15	0.687%	99.3%	0%
Lead	2.58E+02	0.496	1.54	1.09%	98.9%	0%
Mercury	27.6	0.0530	0.0919	0.251%	99.7%	0%
Nickel	43.9	0.0843	0.175	1.06%	98.9%	0%
Zinc	1,509	2.90	4.37	0.985%	99.0%	0%
Total (Sum of Individual Metals)		5.81				
Polyaromatic Hydrocarbons (PAHs)						
Naphthalene	0.134	0.000257	0.0707	0.435%	99.6%	0%
Acenaphthylene	0.0410	0.0000787	0.00311	0.329%	99.7%	0%
Acenaphthene	0.0607	0.000117	0.00282	0.364%	99.6%	0%
Fluorene	0.0418	0.0000802	0.00222	0.461%	99.5%	0%
Phenanthrene	0.178	0.000343	0.0153	0.604%	99.4%	0%
Anthracene	0.0697	0.000134	0.00534	0.576%	99.4%	0%
Fluoranthene	0.332	0.000638	0.0526	0.468%	99.5%	0%
Pyrene	0.477	0.000917	0.0472	0.500%	99.5%	0%
Benz(a)anthracene	0.118	0.000226	0.0222	0.530%	99.5%	0%
Chrysene	0.125	0.000241	0.0372	0.441%	99.6%	0%
Benzo(b)fluoranthene	0.136	0.000261	0.0248	0.435%	99.6%	0%
Benzo(k)fluoranthene	0.0744	0.000143	0.0227	0.384%	99.6%	0%
Benzo(a)pyrene	0.0937	0.000180	0.0249	0.412%	99.6%	0%
Indeno(1,2,3-cd)pyrene	0.0536	0.000103	0.0138	0.446%	99.6%	0%
Dibenz(a,h)anthracene	0.0134	0.0000257	0.00741	0.346%	99.7%	0%
Benzo(g,h,i)perylene	0.0910	0.000175	0.0224	0.321%	99.7%	0%
Total (as reported)	2.04	0.00392	0.375	0.449%	99.6%	0%
Total (Sum of Individual Compounds)		0.00392	0.375			
Total Hydrocarbons						
Light Hydrocarbons (C < 12)			0	#DIV/0!	#DIV/0!	#DIV/0!
Heavy Hydrocarbons (C > 12)			19.7	0.442%	99.6%	0
Total			19.7	0.442%	99.6%	0%

Appendix F: Biogenesis Mass Balance Venice Pilot Demonstration

Batch 2: PC2 CIO Lower Reach						
Process Stream	Centrifuge Stage Mass Balance					
	Mass In		Mass Out			Mass Unaccounted For
Stream Number	Sediment from Cavitation/Oxidation Chamber to Centrifuge	Effluent Water Storage/Treatment to Centrifuge	Centrifuge Solids	Centrifuge Centrate - Dissolved	Centrifuge Centrate - Solids Only	
Units						
Total Mass Input						
Percent Moisture						
Dry Weight Solids						
Water						
Source of Mass						
Source of Moisture Content						
Source of Chemical Info						
Other notes						
	LBS	LBS	PCT	PCT	PCT	PCT
Metals						
Arsenic	1.08	0	33.9%	0.256%	56.2%	9.61%
Cadmium	0.0825	0	29.8%	8.90%	67.2%	-6%
Chromium (total)	0.845	0	32.7%	0.160%	56.9%	10.3%
Copper	2.14	0	30.2%	0.186%	53.0%	16.7%
Lead	1.53	0	21.2%	34.6%	32.5%	11.7%
Mercury	0.0917	0	34.9%	0%	57.8%	7.32%
Nickel	0.173	0	43.2%	8.92%	48.7%	-1%
Zinc	4.33	0	26.4%	36.7%	66.9%	-30%
Total (Sum of Individual Metals)						
Polyaromatic Hydrocarbons (PAHs)						
Naphthalene	0.0704	0	22.4%	1.16%	0.365%	76.0%
Acenaphthylene	0.00310	0	48.1%	0.0483%	2.54%	49.3%
Acenaphthene	0.00281	0	38.0%	0.187%	4.15%	57.6%
Fluorene	0.00221	0	48.2%	0.135%	3.62%	48.0%
Phenanthrene	0.0152	0	79.4%	0.0346%	2.26%	18.3%
Anthracene	0.00531	0	62.3%	0.0282%	2.52%	35.1%
Fluoranthene	0.0524	0	53.0%	0.0100%	1.22%	45.8%
Pyrene	0.0469	0	58.5%	0.0128%	1.95%	39.6%
Benz(a)anthracene	0.0221	0	51.1%	0.0068%	1.02%	47.8%
Chrysene	0.0371	0	40.3%	0.0040%	0.649%	59.0%
Benzo(b)fluoranthene	0.0247	0	55.0%	0.0000%	1.06%	44.0%
Benzo(k)fluoranthene	0.0226	0	56.7%	0.0000%	0.633%	42.7%
Benzo(a)pyrene	0.0248	0	59.4%	0%	0.726%	39.9%
Indeno(1,2,3-cd)pyrene	0.0137	0	56.0%	0%	0.750%	43.3%
Dibenz(a,h)anthracene	0.00739	0	53.4%	0.0710%	0.348%	46.1%
Benzo(g,h,i)perylene	0.0223	0	55.5%	0%	0.783%	43.7%
Total (as reported)	0.373	0	48.6%	0.229%	1.05%	50.1%
Total (Sum of Individual Compounds)						
Total Hydrocarbons						
Light Hydrocarbons (C < 12)	0	0	#DIV/0!	#DIV/0!	#DIV/0!	#DIV/0!
Heavy Hydrocarbons (C > 12)	19.6	0	45.4%	0.0000%	0	54.6%
Total	19.6	0	45.4%	0%	0%	54.6%

Appendix F: Biogenesis Mass Balance Venice Pilot Demonstration

Batch 2: PC2 CIO Lower Reach			
Process Stream	Overall Efficiency		
Stream Number	Mass Inputs	Mass Outputs	Efficiency
Units			
Total Mass Input			
Percent Moisture			
Dry Weight Solids			
Water			
Source of Mass			
Source of Moisture Content			
Source of Chemical Info			
Other notes			
	LBS	LBS	PCT
Metals			
Arsenic	1.09	0.978	10.1%
Cadmium	0.0830	0.0873	-5%
Chromium (total)	0.851	0.760	10.7%
Copper	2.15	1.78	17.1%
Lead	1.54	1.36	11.9%
Mercury	0.0919	0.0847	7.87%
Nickel	0.175	0.175	0%
Zinc	4.37	5.64	-29%
Total (Sum of Individual Metals)			
Polyaromatic Hydrocarbons (PAHs)			
Naphthalene	0.0707	0.0172	75.7%
Acenaphthylene	0.00311	0.00158	49.1%
Acenaphthene	0.00282	0.00120	57.5%
Fluorene	0.00222	0.00116	47.8%
Phenanthrene	0.0153	0.0125	18.2%
Anthracene	0.00534	0.00347	34.9%
Fluoranthene	0.0526	0.0286	45.6%
Pyrene	0.0472	0.0286	39.4%
Benz(a)anthracene	0.0222	0.0117	47.6%
Chrysene	0.0372	0.0153	58.8%
Benzo(b)fluoranthene	0.0248	0.0139	43.8%
Benzo(k)fluoranthene	0.0227	0.0130	42.5%
Benzo(a)pyrene	0.0249	0.0150	39.7%
Indeno(1,2,3-cd)pyrene	0.0138	0.00785	43.1%
Dibenz(a,h)anthracene	0.00741	0.00400	46.0%
Benzo(g,h,i)perylene	0.0224	0.0126	43.6%
Total (as reported)	0.375	0.188	49.9%
Total (Sum of Individual Compounds)	0.375		
Total Hydrocarbons			
Light Hydrocarbons (C < 12)	0	0	#DIV/0!
Heavy Hydrocarbons (C > 12)	19.7	9.00	54.4%
Total	19.7	9.00	54.4%

Appendix F: Biogenesis Mass Balance Venice Pilot Demonstration

Batch 2: PC2 CIO Lower Reach				
Process Stream	Decontamination Efficiency			
Stream Number	Raw Sediment Solids to Pre- Processor	Treated Sediment Removed by Hydrocyclone	Centrifuge Solids	Efficiency
Units				
Total Mass Input				
Percent Moisture				
Dry Weight Solids				
Water				
Source of Mass				
Source of Moisture Content				
Source of Chemical Info				
Other notes				
	LBS	LBS	LBS	PCT
Metals				
Arsenic	1.09	0.00579	0.367	65.7%
Cadmium	0.0830	0.000549	0.0245	69.8%
Chromium (total)	0.851	0.00590	0.276	66.8%
Copper	2.15	0.0148	0.645	69.3%
Lead	1.54	0.0168	0.323	77.9%
Mercury	0.0919	0.000231	0.0320	64.9%
Nickel	0.175	0.00185	0.0747	56.2%
Zinc	4.37	0.0431	1.14	72.9%
Total (Sum of Individual Metals)				
Polyaromatic Hydrocarbons (PAHs)				
Naphthalene	0.0707	0.000308	0.0158	77.2%
Acenaphthylene	0.00311	0.0000103	0.00149	51.7%
Acenaphthene	0.00282	0.0000103	0.00107	61.8%
Fluorene	0.00222	0.0000103	0.00107	51.6%
Phenanthrene	0.0153	0.0000923	0.0121	20.4%
Anthracene	0.00534	0.0000308	0.00331	37.4%
Fluoranthene	0.0526	0.000246	0.0277	46.8%
Pyrene	0.0472	0.000236	0.0274	41.3%
Benz(a)anthracene	0.0222	0.000118	0.0113	48.6%
Chrysene	0.0372	0.000164	0.0149	59.4%
Benzo(b)fluoranthene	0.0248	0.000108	0.0136	44.8%
Benzo(k)fluoranthene	0.0227	0.0000872	0.0128	43.2%
Benzo(a)pyrene	0.0249	0.000103	0.0147	40.5%
Indeno(1,2,3-cd)pyrene	0.0138	0.0000615	0.00768	43.8%
Dibenz(a,h)anthracene	0.00741	0.0000256	0.00395	46.4%
Benzo(g,h,i)perylene	0.0224	0.0000718	0.0124	44.4%
Total (as reported)	0.375	0.00168	0.181	51.2%
Total (Sum of Individual Compounds)	0.375			
Total Hydrocarbons				
Light Hydrocarbons (C < 12)	0	0	0	#DIV/0!
Heavy Hydrocarbons (C > 12)	19.7	0.0872	8.91	54.4%
Total	19.7	0.0872	8.91	54.4%

Appendix F: Biogenesis Mass Balance Venice Pilot Demonstration

Batch 3: PC 3 CIO Nord			
Process Stream	Raw Sediment solids to Pre-Processor	Process Water Addition to Pre-Processor	Cleaning Chemicals to Pre-Processor
Stream Number	1	2	
Units	LBS	LBS	LBS
Total Mass Input	42,485	27,888	
Percent Moisture	70.6%	100%	
Dry Weight Solids	12,508	0	
Water	29,978	27,888	
Source of Mass	Appendix K	The flow rates of water in these streams are not specified in t suggests they should be equal and Appendix K gives th	
Source of Moisture Content	Appendix K		
Source of Chemical Info	Appendix K		
Other notes			
	Conc mg/kg	Mass lb	
Metals			
Arsenic	18.9	0.236	
Cadmium	41.3	0.517	
Chromium (total)	16.7	0.209	
Copper	3.75E+02	4.69	
Lead	5.31E+02	6.64	
Mercury	9.50	0.119	
Nickel	7.40	0.0926	
Zinc	3.37E+02	4.22	
Total (Sum of Individual Metals)		16.7	
Polyaromatic Hydrocarbons (PAHs)			
Naphthalene	1.31	0.0164	
Acenaphthylene	1.85	0.0231	
Acenaphthene	0.780	0.00976	
Fluorene	1.01	0.0126	
Phenanthrene	6.30	0.0788	
Anthracene	4.92	0.0615	
Fluoranthene	49.2	0.615	
Pyrene	19.7	0.246	
Benz(a)anthracene	14.1	0.176	
Chrysene	16.3	0.204	
Benzo(b)fluoranthene	23.3	0.291	
Benzo(k)fluoranthene	11.8	0.148	
Benzo(a)pyrene	10.6	0.133	
Indeno(1,2,3-cd)pyrene	5.88	0.0735	
Dibenz(a,h)anthracene	2.98	0.0373	
Benzo(g,h,i)perylene	5.99	0.0749	
Total (as reported)	1.76E+02	2.20	
Total (Sum of Individual Compounds)		2.20	
Total Hydrocarbons			
Light Hydrocarbons (C < 12)	0	0	
Heavy Hydrocarbons (C > 12)	2,160	27.0	
Total	2,160	27.0	

Appendix F: Biogenesis Mass Balance Venice Pilot Demonstration

Batch 3: PC 3 CIO Nord					
Process Stream	Sediment to Collision Chamber	Process Water Addition to Collision Chamber	Chemical Addition to Collision Chamber		
Stream Number					
Units	LBS	LBS			LBS
Total Mass Input	70,374				
Percent Moisture	82.2%				
Dry Weight Solids	12,508				
Water	57,866				
Source of Mass		Appendix K			
Source of Moisture Content	see report, although table 2-1	Assumed			
Source of Chemical Info	see total for the streams.	Assumed			
Other notes		Assumed pure water			
		Conc	Mass		
		µg/L	lb		
Metals					
Arsenic		0	0		
Cadmium		0	0		
Chromium (total)		0	0		
Copper		0	0		
Lead		0	0		
Mercury		0	0		
Nickel		0	0		
Zinc		0	0		
Total (Sum of Individual Metals)			0		
Polyaromatic Hydrocarbons (PAHs)					
Naphthalene		0	0		
Acenaphthylene		0	0		
Acenaphthene		0	0		
Fluorene		0	0		
Phenanthrene		0	0		
Anthracene		0	0		
Fluoranthene		0	0		
Pyrene		0	0		
Benz(a)anthracene		0	0		
Chrysene		0	0		
Benzo(b)fluoranthene		0	0		
Benzo(k)fluoranthene		0	0		
Benzo(a)pyrene		0	0		
Indeno(1,2,3-cd)pyrene		0	0		
Dibenzo(a,h)anthracene		0	0		
Benzo(g,h,i)perylene		0	0		
Total (as reported)		0	0		
Total (Sum of Individual Compounds)			0		
Total Hydrocarbons					
Light Hydrocarbons (C < 12)		0	0		
Heavy Hydrocarbons (C > 12)		0	0		
Total		0	0		

Appendix F: Biogenesis Mass Balance Venice Pilot Demonstration

Batch 3: PC 3 CIO Nord						
Process Stream	Sediment from Collision Chamber to Hydrocyclone		Treated Sediment Removed by Hydrocyclone		Sediment to Cavitation/Oxidation Chamber	
Stream Number	3		3r		4	
Units	LBS		LBS		LBS	
Total Mass Input	70,374		778		69,596	
Percent Moisture	82.2%		20.6%		82.9%	
Dry Weight Solids	12,508		617		11,890	
Water	57,866		160		57,706	
Source of Mass	Calculated (1a+2a+1)		Solid Mass Calculations		Calculated	
Source of Moisture Content	Calculated		Measured (Table 4-2-5)		Calculated	
Source of Chemical Info	Calculated		Measured (Table 4-2-5)		Calculated	
Other notes						
	Conc mg/kg	Mass lb	Conc mg/kg	Mass lb	Conc mg/kg	Mass lb
Metals						
Arsenic	18.9	0.236	12.5	0.00772	19.2	0.229
Cadmium	41.3	0.517	8.90	0.00549	43.0	0.511
Chromium (total)	16.7	0.209	12.2	0.00753	16.9	0.201
Copper	3.75E+02	4.69	35.4	0.0219	3.93E+02	4.67
Lead	5.31E+02	6.64	1.38E+02	0.0852	5.51E+02	6.56
Mercury	9.50	0.119	1.49	0.000920	9.92	0.118
Nickel	7.40	0.0926	8.20	0.00506	7.36	0.0875
Zinc	3.37E+02	4.22	6.30E+02	0.389	3.22E+02	3.83
Total (Sum of Individual Metals)		16.7		0.523		16.2
Polyaromatic Hydrocarbons (PAHs)						
Naphthalene	1.31	0.0164	0.760	0.000469	1.34	0.0159
Acenaphthylene	1.85	0.0231	0.190	0.000117	1.94	0.0230
Acenaphthene	0.780	0.00976	0.100	0.0000617	0.815	0.00969
Fluorene	1.01	0.0126	0.0900	0.0000556	1.06	0.0126
Phenanthrene	6.30	0.0788	0.570	0.000352	6.60	0.0784
Anthracene	4.92	0.0615	0.370	0.000228	5.16	0.0613
Fluoranthene	49.2	0.615	3.52	0.00217	51.6	0.613
Pyrene	19.7	0.246	1.73	0.00107	20.6	0.245
Benz(a)anthracene	14.1	0.176	1.15	0.000710	14.8	0.176
Chrysene	16.3	0.204	1.40	0.000864	17.1	0.203
Benzo(b)fluoranthene	23.3	0.291	1.41	0.000870	24.4	0.291
Benzo(k)fluoranthene	11.8	0.148	1.10	0.000679	12.4	0.147
Benzo(a)pyrene	10.6	0.133	0.970	0.000599	11.1	0.132
Indeno(1,2,3-cd)pyrene	5.88	0.0735	0.480	0.000296	6.16	0.0732
Dibenz(a,h)anthracene	2.98	0.0373	0.230	0.000142	3.12	0.0371
Benzo(g,h,i)perylene	5.99	0.0749	0.500	0.000309	6.28	0.0746
Total (as reported)	1.76E+02	2.20	14.6	0.00900	1.84E+02	2.19
Total (Sum of Individual Compounds)		2.20		0.00900		2.19
Total Hydrocarbons						
Light Hydrocarbons (C < 12)	0	0	0	0	0	0
Heavy Hydrocarbons (C > 12)	2,160	27.0	86.0	0.0531	2,268	27.0
Total	2,160	27.0	86.0	0.0531	2,268	27.0

Appendix F: Biogenesis Mass Balance Venice Pilot Demonstration

Batch 3: PC 3 CIO Nord			
Process Stream	Sediment from Cavitation/ Oxidation Chamber to Centrifuge	Cavitation/Oxidation Chamber Water to Effluent Water Storage/Treatment	Effluent Water Storage/Treatment to Centrifuge
Stream Number	5		
Units	LBS	LBS	LBS
Total Mass Input	69,596		
Percent Moisture	82.9%		
Dry Weight Solids	11,890		
Water	57,706		
Source of Mass	Calculated		
Source of Moisture Content	Calculated		
Source of Chemical Info	Calculated		
Other notes			
	Conc mg/kg	Mass lb	
Metals			
Arsenic	19.2	0.229	
Cadmium	43.0	0.511	
Chromium (total)	16.9	0.201	
Copper	3.93E+02	4.67	
Lead	5.51E+02	6.56	
Mercury	9.92	0.118	
Nickel	7.36	0.0875	
Zinc	3.22E+02	3.83	
Total (Sum of Individual Metals)		16.2	
Polyaromatic Hydrocarbons (PAHs)			
Naphthalene	1.34	0.0159	
Acenaphthylene	1.94	0.0230	
Acenaphthene	0.815	0.00969	
Fluorene	1.06	0.0126	
Phenanthrene	6.60	0.0784	
Anthracene	5.16	0.0613	
Fluoranthene	51.6	0.613	
Pyrene	20.6	0.245	
Benzo(a)anthracene	14.8	0.176	
Chrysene	17.1	0.203	
Benzo(b)fluoranthene	24.4	0.291	
Benzo(k)fluoranthene	12.4	0.147	
Benzo(a)pyrene	11.1	0.132	
Indeno(1,2,3-cd)pyrene	6.16	0.0732	
Dibenz(a,h)anthracene	3.12	0.0371	
Benzo(g,h,i)perylene	6.28	0.0746	
Total (as reported)	1.84E+02	2.19	
Total (Sum of Individual Compounds)		2.19	
Total Hydrocarbons			
Light Hydrocarbons (C < 12)	0	0	
Heavy Hydrocarbons (C > 12)	2,268	27.0	
Total	2,268	27.0	

Appendix F: Biogenesis Mass Balance Venice Pilot Demonstration

Batch 3: PC 3 CIO Nord						
Process Stream	Centrifuge Solids		Centrifuge Centrate		Centrifuge Centrate - Dissolved	
Stream Number	6		7			
Units	LBS		LBS		LBS	
Total Mass Input	12,918		56,678		53,482	
Percent Moisture	32.7%		97.5%		100%	
Dry Weight Solids	8,694		3,196			
Water	4,224		53,482		53,482	
Source of Mass	Solid Mass Calculations		Solid Mass Calculations		Water Balance	
Source of Moisture Content	Measured (Table 4-2-5)		Water Balance		N/A	
Source of Chemical Info	Measured (Table 4-2-5)		Appendix K		Appendix K	
Other notes						
	Conc mg/kg	Mass lb	Conc µg/L	Mass lb	Conc µg/L	Mass lb
Metals						
Arsenic	38.1	0.331	14,900	0.797	1.66E+02	0.00888
Cadmium	10.2	0.0887	4,190	0.224	1.35E+02	0.00722
Chromium (total)	22.0	0.191	4,110	0.220	0	0
Copper	72.5	0.630	38,900	2.08	25.0	0.00134
Lead	2.74E+02	2.38	87,700	4.69	45,600	2.44
Mercury	7.10	0.0617	1,270	0.0679	0	0
Nickel	14.6	0.127	1,470	0.0786	1.74E+02	0.00931
Zinc	1,010	8.78	52,700	2.82	42,500	2.27
Total (Sum of Individual Metals)		12.6		11.0		4.74
Polyaromatic Hydrocarbons (PAHs)						
Naphthalene	1.49	0.0130	57.1	0.00305	0.0800	0.00000428
Acenaphthylene	1.96	0.0170	15.1	0.000808	0.0600	0.00000321
Acenaphthene	0.630	0.00548	25.5	0.00136	0	0
Fluorene	0.720	0.00626	16.1	0.000861	0	0
Phenanthrene	3.94	0.0343	78.6	0.00420	0.0700	0.00000374
Anthracene	3.39	0.0295	42.2	0.00226	0.130	0.00000695
Fluoranthene	28.1	0.244	6.46E+02	0.0345	0.830	0.0000444
Pyrene	15.0	0.130	2.53E+02	0.0135	0.410	0.0000219
Benz(a)anthracene	9.16	0.0796	1.19E+02	0.00636	0.200	0.0000107
Chrysene	12.7	0.110	1.19E+02	0.00636	0.170	0.00000909
Benzo(b)fluoranthene	15.3	0.133	89.2	0.00477	0.0700	0.00000374
Benzo(k)fluoranthene	10.9	0.0948	77.4	0.00414	0.140	0.00000749
Benzo(a)pyrene	10.0	0.0869	77.4	0.00414	0.140	0.00000749
Indeno(1,2,3-cd)pyrene	5.72	0.0497	38.5	0.00206	0.0400	0.00000214
Dibenz(a,h)anthracene	2.96	0.0257	21.0	0.00112	0	0
Benzo(g,h,i)perylene	5.46	0.0475	45.1	0.00241	0.0400	0.00000214
Total (as reported)	1.27E+02	1.11	1,720	0.0920	2.40	0.000128
Total (Sum of Individual Compounds)		1.11		0.0920		0.000127
Total Hydrocarbons						
Light Hydrocarbons (C < 12)	0	0	0	0		
Heavy Hydrocarbons (C > 12)	7.13E+02	6.20	0	0		
Total	7.13E+02	6.20	0	0		

Appendix F: Biogenesis Mass Balance Venice Pilot Demonstration

Batch 3: PC 3 CIO Nord						
Process Stream	Centrifuge Centrate - Solid Only		Hydrocyclone Stage Mass Balance			
			Mass In	Mass Out		Mass Unaccounted For
Stream Number			Sediment from Collision Chamber to Hydrocyclone	Treated Sediment Removed by Hydrocyclone	Sediment to Cavitation/Oxidation Chamber	
Units	LBS					
Total Mass Input	3,196					
Percent Moisture	0					
Dry Weight Solids	3,196					
Water						
Source of Mass	Solid Mass Calculations					
Source of Moisture Content	N/A					
Source of Chemical Info	Calculated					
Other notes						
	Conc mg/kg	Mass lb		PCT	PCT	PCT
Metals						
Arsenic	2.48E+02	0.792	0.236	3.26%	96.7%	0%
Cadmium	68.2	0.218	0.517	1.06%	98.9%	0%
Chromium (total)	69.2	0.221	0.209	3.61%	96.4%	0%
Copper	6.54E+02	2.09	4.69	0.466%	99.5%	0%
Lead	7.08E+02	2.26	6.64	1.28%	98.7%	0%
Mercury	21.4	0.0683	0.119	0.774%	99.2%	0%
Nickel	21.8	0.0697	0.0926	5.47%	94.5%	0%
Zinc	1.72E+02	0.549	4.22	9.23%	90.8%	0%
Total (Sum of Individual Metals)		6.27	16.7			
Polyaromatic Hydrocarbons (PAHs)						
Naphthalene	0.959	0.00307	0.0164	2.86%	97.1%	0%
Acenaphthylene	0.253	0.000809	0.0231	0.507%	99.5%	0%
Acenaphthene	0.429	0.00137	0.00976	0.633%	99.4%	0%
Fluorene	0.271	0.000866	0.0126	0.440%	99.6%	0%
Phenanthrene	1.32	0.00422	0.0788	0.447%	99.6%	0%
Anthracene	0.708	0.00226	0.0615	0.371%	99.6%	0%
Fluoranthene	10.9	0.0347	0.615	0.353%	99.6%	0%
Pyrene	4.25	0.0136	0.246	0.433%	99.6%	0%
Benz(a)anthracene	2.00	0.00639	0.176	0.403%	99.6%	0%
Chrysene	2.00	0.00639	0.204	0.424%	99.6%	0%
Benzo(b)fluoranthene	1.50	0.00479	0.291	0.299%	99.7%	0%
Benzo(k)fluoranthene	1.30	0.00416	0.148	0.460%	99.5%	0%
Benzo(a)pyrene	1.30	0.00416	0.133	0.452%	99.5%	0%
Indeno(1,2,3-cd)pyrene	0.647	0.00207	0.0735	0.403%	99.6%	0%
Dibenz(a,h)anthracene	0.353	0.00113	0.0373	0.381%	99.6%	0%
Benzo(g,h,i)perylene	0.758	0.00242	0.0749	0.412%	99.6%	0%
Total (as reported)	28.9	0.0924	2.20	0.409%	99.6%	0%
Total (Sum of Individual Compounds)		0.0924	2.20			
Total Hydrocarbons						
Light Hydrocarbons (C < 12)			0			
Heavy Hydrocarbons (C > 12)			27.0	0.197%	99.8%	0
Total			27.0	0.197%	99.8%	0%

Appendix F: Biogenesis Mass Balance Venice Pilot Demonstration

Batch 3: PC 3 CIO Nord						
Process Stream	Centrifuge Stage Mass Balance					
Stream Number	Mass In		Mass Out			Mass Unaccounted For
Units	Sediment from Cavitation/Oxidation Chamber to Centrifuge	Effluent Water Storage/Treatment to Centrifuge	Centrifuge Solids	Centrifuge Centrate - Dissolved	Centrifuge Centrate - Solids Only	
Total Mass Input						
Percent Moisture						
Dry Weight Solids						
Water						
Source of Mass						
Source of Moisture Content						
Source of Chemical Info						
Other notes						
	LBS	LBS	PCT	PCT	PCT	PCT
Metals						
Arsenic	0.229	0	145%	3.88%	347%	-395%
Cadmium	0.511	0	17.4%	1.41%	42.7%	38.6%
Chromium (total)	0.201	0	95.0%	0.000%	110%	-105%
Copper	4.67	0	13.5%	0.0286%	44.8%	41.7%
Lead	6.56	0	36.3%	37.2%	34.5%	-8%
Mercury	0.118	0	52.4%	0%	57.9%	-10%
Nickel	0.0875	0	145%	10.6%	79.7%	-135%
Zinc	3.83	0	229%	59.4%	14.3%	-203%
Total (Sum of Individual Metals)						
Polyaromatic Hydrocarbons (PAHs)						
Naphthalene	0.0159	0	81.4%	0.0269%	19.3%	-0.7%
Acenaphthylene	0.0230	0	74.0%	0.0139%	3.51%	22.5%
Acenaphthene	0.00969	0	56.5%	0.0000%	14.1%	29.4%
Fluorene	0.0126	0	49.8%	0.0000%	6.88%	43.3%
Phenanthrene	0.0784	0	43.7%	0.0048%	5.38%	50.9%
Anthracene	0.0613	0	48.1%	0.0113%	3.69%	48.2%
Fluoranthene	0.613	0	39.8%	0.0072%	5.66%	54.5%
Pyrene	0.245	0	53.2%	0.0089%	5.54%	41.3%
Benzo(a)anthracene	0.176	0	45.3%	0.0061%	3.64%	51.0%
Chrysene	0.203	0	54.4%	0.0045%	3.15%	42.5%
Benzo(b)fluoranthene	0.291	0	45.8%	0.0013%	1.65%	52.6%
Benzo(k)fluoranthene	0.147	0	64.5%	0.0051%	2.83%	32.7%
Benzo(a)pyrene	0.132	0	65.9%	0%	3.15%	31.0%
Indeno(1,2,3-cd)pyrene	0.0732	0	67.9%	0%	2.82%	29.3%
Dibenz(a,h)anthracene	0.0371	0	69.3%	0%	3.04%	27.7%
Benzo(g,h,i)perylene	0.0746	0	63.6%	0%	3.25%	33.1%
Total (as reported)	2.19	0	50.5%	0.0059%	4.21%	45.3%
Total (Sum of Individual Compounds)						
Total Hydrocarbons						
Light Hydrocarbons (C < 12)	0	0				
Heavy Hydrocarbons (C > 12)	27.0	0	23.0%	0.0000%	0	77.0%
Total	27.0	0	23.0%	0%	0%	77.0%

Appendix F: Biogenesis Mass Balance Venice Pilot Demonstration

Batch 3: PC 3 CIO Nord			
Process Stream	Overall Efficiency		
Stream Number			
Units			
Total Mass Input			
Percent Moisture			
Dry Weight Solids	Mass Inputs	Mass Outputs	Efficiency
Water			
Source of Mass			
Source of Moisture Content			
Source of Chemical Info			
Other notes			
	LBS	LBS	PCT
Metals			
Arsenic	0.236	1.14	-380%
Cadmium	0.517	0.318	38.4%
Chromium (total)	0.209	0.419	-100%
Copper	4.69	2.73	41.7%
Lead	6.64	7.16	-8%
Mercury	0.119	0.131	-10%
Nickel	0.0926	0.211	-128%
Zinc	4.22	12.0	-184%
Total (Sum of Individual Metals)	16.7		
Polyaromatic Hydrocarbons (PAHs)			
Naphthalene	0.0164	0.0165	-0.6%
Acenaphthylene	0.0231	0.0180	22.4%
Acenaphthene	0.00976	0.00690	29.2%
Fluorene	0.0126	0.00718	43.2%
Phenanthrene	0.0788	0.0388	50.7%
Anthracene	0.0615	0.0320	48.1%
Fluoranthene	0.615	0.281	54.3%
Pyrene	0.246	0.145	41.1%
Benz(a)anthracene	0.176	0.0867	50.8%
Chrysene	0.204	0.118	42.3%
Benzo(b)fluoranthene	0.291	0.139	52.4%
Benzo(k)fluoranthene	0.148	0.0996	32.5%
Benzo(a)pyrene	0.133	0.0917	30.9%
Indeno(1,2,3-cd)pyrene	0.0735	0.0521	29.2%
Dibenz(a,h)anthracene	0.0373	0.0270	27.6%
Benzo(g,h,i)perylene	0.0749	0.0502	33.0%
Total (as reported)	2.20	1.21	45.1%
Total (Sum of Individual Compounds)	2.20		
Total Hydrocarbons			
Light Hydrocarbons (C < 12)	0	0	
Heavy Hydrocarbons (C > 12)	27.0	6.25	76.9%
Total	27.0	6.25	76.9%

Appendix F: Biogenesis Mass Balance Venice Pilot Demonstration

Batch 3: PC 3 CIO Nord				
Process Stream	Decontamination Efficiency			
Stream Number	Raw Sediment Solids to Pre- Processor	Treated Sediment Removed by Hydrocyclone	Centrifuge Solids	Efficiency
Units				
Total Mass Input				
Percent Moisture				
Dry Weight Solids				
Water				
Source of Mass				
Source of Moisture Content				
Source of Chemical Info				
Other notes				
	LBS	LBS	LBS	PCT
Metals				
Arsenic	0.236	0.00772	0.331	-43%
Cadmium	0.517	0.00549	0.0887	81.8%
Chromium (total)	0.209	0.00753	0.191	4.83%
Copper	4.69	0.0219	0.630	86.1%
Lead	6.64	0.0852	2.38	62.9%
Mercury	0.119	0.000920	0.0617	47.3%
Nickel	0.0926	0.00506	0.127	-42.6%
Zinc	4.22	0.389	8.78	-118%
Total (Sum of Individual Metals)	16.7			
Polyaromatic Hydrocarbons (PAHs)				
Naphthalene	0.0164	0.000469	0.0130	18.1%
Acenaphthylene	0.0231	0.000117	0.0170	25.9%
Acenaphthene	0.00976	0.0000617	0.00548	43.2%
Fluorene	0.0126	0.0000556	0.00626	50.0%
Phenanthrene	0.0788	0.000352	0.0343	56.1%
Anthracene	0.0615	0.000228	0.0295	51.7%
Fluoranthene	0.615	0.00217	0.244	59.9%
Pyrene	0.246	0.00107	0.130	46.6%
Benz(a)anthracene	0.176	0.000710	0.0796	54.4%
Chrysene	0.204	0.000864	0.110	45.4%
Benzo(b)fluoranthene	0.291	0.000870	0.133	54.1%
Benzo(k)fluoranthene	0.148	0.000679	0.0948	35.3%
Benzo(a)pyrene	0.133	0.000599	0.0869	34.0%
Indeno(1,2,3-cd)pyrene	0.0735	0.000296	0.0497	32.0%
Dibenz(a,h)anthracene	0.0373	0.000142	0.0257	30.6%
Benzo(g,h,i)perylene	0.0749	0.000309	0.0475	36.2%
Total (as reported)	2.20	0.00900	1.11	49.3%
Total (Sum of Individual Compounds)	2.20			
Total Hydrocarbons				
Light Hydrocarbons (C < 12)	0	0	0	
Heavy Hydrocarbons (C > 12)	27.0	0.0531	6.20	76.9%
Total	27.0	0.0531	6.20	76.9%

Appendix F: Biogenesis Mass Balance Venice Pilot Demonstration

Batch 4: PC 1 CIO Upper Reach			
Process Stream	Raw Sediment solids to Pre-Processor	Process Water Addition to Pre-Processor	Cleaning Chemicals to Pre-Processor
Stream Number	1	2	
Units	LBS	LBS	LBS
Total Mass Input	40,038	42,990	
Percent Moisture	72.9%	100%	
Dry Weight Solids	10,850	0	
Water	29,188	42,990	
Source of Mass	Appendix K	The flow rates of water in these streams are not specified in the report. This suggests they should be equal and Appendix K gives the flow rates.	
Source of Moisture Content	Appendix K		
Source of Chemical Info	Appendix K		
Other notes			
	Conc mg/kg	Mass lb	
Metals			
Arsenic	8.99	0.0975	
Cadmium	4.40	0.0477	
Chromium (total)	16.4	0.177	
Copper	78.4	0.851	
Lead	38.2	0.414	
Mercury	4.18	0.0454	
Nickel	7.05	0.0765	
Zinc	1.31E+02	1.42	
Total (Sum of individual metals)		3.13	
Polyaromatic Hydrocarbons (PAHs)			
Naphthalene	2.02	0.0219	
Acenaphthylene	0.575	0.00624	
Acenaphthene	0.480	0.00521	
Fluorene	0.350	0.00380	
Phenanthrene	1.53	0.0166	
Anthracene	0.530	0.00575	
Fluoranthene	4.52	0.0490	
Pyrene	3.10	0.0336	
Benzo(a)anthracene	1.18	0.0127	
Chrysene	1.52	0.0164	
Benzo(b)fluoranthene	1.75	0.0190	
Benzo(k)fluoranthene	1.41	0.0153	
Benzo(a)pyrene	1.03	0.0111	
Indeno(1,2,3-cd)pyrene	0.875	0.00949	
Dibenzo(a,h)anthracene	0.295	0.00320	
Benzo(g,h,i)perylene	1.58	0.0171	
Total (as reported)	22.7	0.246	
Total (Sum of individual compounds)		0.246	
Total Hydrocarbons			
Light Hydrocarbons (C < 12)	0		
Heavy Hydrocarbons (C > 12)	8.57E+02		
Total	8.57E+02	9.29	

Appendix F: Biogenesis Mass Balance Venice Pilot Demonstration

Batch 4: PC 1 CIO Upper Reach			
Process Stream	Sediment to Collision Chamber	Process Water Addition to Collision Chamber	Chemical Addition to Collision Chamber
Stream Number			
Units	LBS	LBS	LBS
Total Mass Input	83,028		
Percent Moisture	86.9%		
Dry Weight Solids	10,850		
Water	72,178		
Source of Mass		Appendix K	
Source of Moisture Content	see report, although table 2-1	Assumed	
Source of Chemical Info	see total for the streams.	Assumed	
Other notes		Assumed pure water	
		Conc	Mass
		µg/L	lb
Metals			
Arsenic		0	0
Cadmium		0	0
Chromium (total)		0	0
Copper		0	0
Lead		0	0
Mercury		0	0
Nickel		0	0
Zinc		0	0
Total (Sum of individual metals)		0	0
Polyaromatic Hydrocarbons (PAHs)			
Naphthalene		0	0
Acenaphthylene		0	0
Acenaphthene		0	0
Fluorene		0	0
Phenanthrene		0	0
Anthracene		0	0
Fluoranthene		0	0
Pyrene		0	0
Benz(a)anthracene		0	0
Chrysene		0	0
Benzo(b)fluoranthene		0	0
Benzo(k)fluoranthene		0	0
Benzo(a)pyrene		0	0
Indeno(1,2,3-cd)pyrene		0	0
Dibenz(a,h)anthracene		0	0
Benzo(g,h,i)perylene		0	0
Total (as reported)		0	0
Total (Sum of individual compounds)		0	0
Total Hydrocarbons			
Light Hydrocarbons (C < 12)			
Heavy Hydrocarbons (C > 12)			
Total		0	0

Appendix F: Biogenesis Mass Balance Venice Pilot Demonstration

Batch 4: PC 1 CIO Upper Reach						
Process Stream	Sediment from Collision Chamber to Hydrocyclone		Treated Sediment Removed by Hydrocyclone		Sediment to Cavitation/Oxidation Chamber	
Stream Number	3		3r		4	
Units	LBS		LBS		LBS	
Total Mass Input	83,028		1,367		81,662	
Percent Moisture	86.9%		24.9%		88.0%	
Dry Weight Solids	10,850		1,026		9,824	
Water	72,178		340		71,838	
Source of Mass	Calculated (1a+2a+1)		Solid Mass Calculations		Calculated	
Source of Moisture Content	Calculated		Measured (Table 4-2-5)		Calculated	
Source of Chemical Info	Calculated		Measured (Table 4-2-5)		Calculated	
Other notes						
	Conc mg/kg	Mass lb	Conc mg/kg	Mass lb	Conc mg/kg	Mass lb
Metals						
Arsenic	8.99	0.0975	14.9	0.0153	8.37	0.0822
Cadmium	4.40	0.0477	8.00	0.00821	4.02	0.0395
Chromium (total)	16.4	0.177	19.3	0.0198	16.0	0.158
Copper	78.4	0.851	38.9	0.0399	82.5	0.811
Lead	38.2	0.414	58.9	0.0604	36.0	0.353
Mercury	4.18	0.0454	0.660	0.000677	4.55	0.0447
Nickel	7.05	0.0765	11.0	0.0113	6.64	0.0652
Zinc	1.31E+02	1.42	3.45E+02	0.354	1.08E+02	1.06
Total (Sum of individual metals)		3.13		0.510		2.62
Polyaromatic Hydrocarbons (PAHs)						
Naphthalene	2.02	0.0219	0.330	0.000339	2.19	0.0215
Acenaphthylene	0.575	0.00624	0.0500	0.0000513	0.630	0.00619
Acenaphthene	0.480	0.00521	0.0400	0.0000411	0.526	0.00517
Fluorene	0.350	0.00380	0.0400	0.0000411	0.382	0.00376
Phenanthrene	1.53	0.0166	0.150	0.000154	1.67	0.0164
Anthracene	0.530	0.00575	0.0700	0.0000718	0.578	0.00568
Fluoranthene	4.52	0.0490	0.810	0.000831	4.90	0.0482
Pyrene	3.10	0.0336	0.420	0.000431	3.38	0.0332
Benz(a)anthracene	1.18	0.0127	0.190	0.000195	1.28	0.0126
Chrysene	1.52	0.0164	0.250	0.000257	1.65	0.0162
Benzo(b)fluoranthene	1.75	0.0190	0.270	0.000277	1.90	0.0187
Benzo(k)fluoranthene	1.41	0.0153	0.180	0.000185	1.54	0.0151
Benzo(a)pyrene	1.03	0.0111	0.150	0.000154	1.12	0.0110
Indeno(1,2,3-cd)pyrene	0.875	0.00949	0.100	0.000103	0.956	0.00939
Dibenz(a,h)anthracene	0.295	0.00320	0.0400	0.0000411	0.322	0.00316
Benzo(g,h,i)perylene	1.58	0.0171	0.120	0.000123	1.73	0.0170
Total (as reported)	22.7	0.246	3.21	0.00329	24.8	0.243
Total (Sum of individual compounds)		0.246		0.00329		0.243
Total Hydrocarbons						
Light Hydrocarbons (C < 12)	0	0	0			
Heavy Hydrocarbons (C > 12)	8.57E+02		86.0			
Total	8.57E+02	9.29	86.0	0.0883	9.37E+02	9.21

Appendix F: Biogenesis Mass Balance Venice Pilot Demonstration

Batch 4: PC 1 CIO Upper Reach			
Process Stream	Sediment from Cavitation/ Oxidation Chamber to Centrifuge	Cavitation/Oxidation Chamber Water to Effluent Water Storage/Treatment	Effluent Water Storage/Treatment to Centrifuge
Stream Number	5		
Units	LBS	LBS	LBS
Total Mass Input	81,662		
Percent Moisture	88.0%		
Dry Weight Solids	9,824		
Water	71,838		
Source of Mass	Calculated		
Source of Moisture Content	Calculated		
Source of Chemical Info	Calculated		
Other notes			
	Conc mg/kg	Mass lb	
Metals			
Arsenic	8.37	0.0822	
Cadmium	4.02	0.0395	
Chromium (total)	16.0	0.158	
Copper	82.5	0.811	
Lead	36.0	0.353	
Mercury	4.55	0.0447	
Nickel	6.64	0.0652	
Zinc	1.08E+02	1.06	
Total (Sum of individual metals)		2.62	
Polyaromatic Hydrocarbons (PAHs)			
Naphthalene	2.19	0.0215	
Acenaphthylene	0.630	0.00619	
Acenaphthene	0.526	0.00517	
Fluorene	0.382	0.00376	
Phenanthrene	1.67	0.0164	
Anthracene	0.578	0.00568	
Fluoranthene	4.90	0.0482	
Pyrene	3.38	0.0332	
Benz(a)anthracene	1.28	0.0126	
Chrysene	1.65	0.0162	
Benzo(b)fluoranthene	1.90	0.0187	
Benzo(k)fluoranthene	1.54	0.0151	
Benzo(a)pyrene	1.12	0.0110	
Indeno(1,2,3-cd)pyrene	0.956	0.00939	
Dibenz(a,h)anthracene	0.322	0.00316	
Benzo(g,h,i)perylene	1.73	0.0170	
Total (as reported)	24.8	0.243	
Total (Sum of individual compounds)		0.243	
Total Hydrocarbons			
Light Hydrocarbons (C < 12)			
Heavy Hydrocarbons (C > 12)			
Total	9.37E+02	9.21	

Appendix F: Biogenesis Mass Balance Venice Pilot Demonstration

Batch 4: PC 1 CIO Upper Reach						
Process Stream	Centrifuge Solids		Centrifuge Centrate		Centrifuge Centrate - Dissolved	
Stream Number	6		7			
Units	LBS		LBS		LBS	
Total Mass Input	10,999		70,663		68,780	
Percent Moisture	27.8%		97.3%		100%	
Dry Weight Solids	7,941		1,883			
Water	3,058		68,780		68,780	
Source of Mass	Solid Mass Calculations		Solid Mass Calculations		Water Balance	
Source of Moisture Content	Measured (Table 4-2-5)		Water Balance		N/A	
Source of Chemical Info	Measured (Table 4-2-5)		Appendix K		Appendix K	
Other notes						
	Conc	Mass	Conc	Mass	Conc	Mass
	mg/kg	lb	µg/L	lb	µg/L	lb
Metals						
Arsenic	27.4	0.218	10,900	0.750	1.78E+02	0.0122
Cadmium	8.00	0.0635	2,520	0.173	1,010	0.0695
Chromium (total)	25.6	0.203	4,920	0.338	22.0	0.00151
Copper	51.7	0.411	26,700	1.84	97.0	0.00667
Lead	95.1	0.755	59,700	4.11	22,800	1.57
Mercury	3.15	0.0250	1,350	0.0929	0	0
Nickel	11.4	0.0905	2,260	0.155	3.53E+02	0.0243
Zinc	4.52E+02	3.59	1.09E+05	7.50	61,500	4.23
Total (Sum of individual metals)		5.36		14.9		5.91
Polyaromatic Hydrocarbons (PAHs)						
Naphthalene	1.74	0.0138	16.4	0.00113	0.0400	0.00000275
Acenaphthylene	0.880	0.00699	20.0	0.00138	0.0400	0.00000275
Acenaphthene	0.510	0.00405	26.9	0.00185	0.0500	0.00000344
Fluorene	0.460	0.00365	19.5	0.00134	0.0400	0.00000275
Phenanthrene	2.11	0.0168	89.7	0.00617	0.0600	0.00000413
Anthracene	1.24	0.00985	39.6	0.00272	0.0400	0.00000275
Fluoranthene	8.37	0.0665	5.73E+02	0.0394	0.370	0.0000254
Pyrene	5.10	0.0405	3.17E+02	0.0218	0.170	0.0000117
Benz(a)anthracene	3.33	0.0264	1.18E+02	0.00812	0.0800	0.00000550
Chrysene	4.07	0.0323	1.11E+02	0.00763	0.100	0.00000688
Benzo(b)fluoranthene	1.85	0.0147	85.6	0.00589	0.0600	0.00000413
Benzo(k)fluoranthene	2.95	0.0234	61.8	0.00425	0.0800	0.00000550
Benzo(a)pyrene	2.18	0.0173	62.4	0.00429	0	0
Indeno(1,2,3-cd)pyrene	1.35	0.0107	33.0	0.00227	0.0200	0.00000138
Dibenz(a,h)anthracene	0.670	0.00532	15.3	0.00105	0	0
Benzo(g,h,i)perylene	1.62	0.0129	48.2	0.00332	0.0300	0.00000206
Total (as reported)	38.4	0.305	1,637	0.113	1.20	0.0000825
Total (Sum of individual compounds)		0.305		0.113		0.0000812
Total Hydrocarbons						
Light Hydrocarbons (C < 12)	0		0			
Heavy Hydrocarbons (C > 12)	3.97E+02		0			
Total	3.97E+02	3.15	0	0		

Appendix F: Biogenesis Mass Balance Venice Pilot Demonstration

Batch 4: PC 1 CIO Upper Reach						
Process Stream	Centrifuge Centrate - Solid Only		Hydrocyclone Stage Mass Balance			
	Stream Number		Mass In	Mass Out		Mass Unaccounted For
Units	LBS		Sediment from Collision Chamber to Hydrocyclone	Treated Sediment Removed by Hydrocyclone	Sediment to Cavitation/Oxidation Chamber	
Total Mass Input	1,883					
Percent Moisture	0					
Dry Weight Solids	1,883					
Water						
Source of Mass	Solid Mass Calculations					
Source of Moisture Content	N/A					
Source of Chemical Info	Calculated					
Other notes						
	Conc mg/kg	Mass lb	LBS	PCT	PCT	PCT
Metals						
Arsenic	3.92E+02	0.737	0.0975	15.7%	84.3%	0%
Cadmium	55.2	0.104	0.0477	17.2%	82.8%	0%
Chromium (total)	1.79E+02	0.337	0.177	11.2%	88.8%	0%
Copper	9.72E+02	1.83	0.851	4.69%	95.3%	0%
Lead	1,348	2.54	0.414	14.6%	85.4%	0%
Mercury	49.3	0.0929	0.0454	1.49%	98.5%	0%
Nickel	69.7	0.131	0.0765	14.8%	85.2%	0%
Zinc	1,735	3.27	1.42	25.0%	75.0%	0%
Total (Sum of individual metals)		9.04				
Polyaromatic Hydrocarbons (PAHs)						
Naphthalene	0.598	0.00113	0.0219	1.55%	98.5%	0%
Acenaphthylene	0.729	0.00137	0.00624	0.822%	99.2%	0%
Acenaphthene	0.981	0.00185	0.00521	0.788%	99.2%	0%
Fluorene	0.711	0.00134	0.00380	1.08%	98.9%	0%
Phenanthrene	3.27	0.00617	0.0166	0.927%	99.1%	0%
Anthracene	1.45	0.00272	0.00575	1.25%	98.8%	0%
Fluoranthene	20.9	0.0394	0.0490	1.70%	98.3%	0%
Pyrene	11.6	0.0218	0.0336	1.28%	98.7%	0%
Benzo(a)anthracene	4.31	0.00811	0.0127	1.53%	98.5%	0%
Chrysene	4.05	0.00763	0.0164	1.56%	98.4%	0%
Benzo(b)fluoranthene	3.12	0.00588	0.0190	1.46%	98.5%	0%
Benzo(k)fluoranthene	2.25	0.00425	0.0153	1.21%	98.8%	0%
Benzo(a)pyrene	2.28	0.00429	0.0111	1.38%	98.6%	0%
Indeno(1,2,3-cd)pyrene	1.20	0.00227	0.00949	1.08%	98.9%	0%
Dibenzo(a,h)anthracene	0.559	0.00105	0.00320	1.28%	98.7%	0%
Benzo(g,h,i)perylene	1.76	0.00331	0.0171	0.721%	99.3%	0%
Total (as reported)	59.8	0.113	0.246	1.34%	98.7%	0%
Total (Sum of individual compounds)		0.113	0.246			
Total Hydrocarbons						
Light Hydrocarbons (C < 12)			0			
Heavy Hydrocarbons (C > 12)			0			
Total			9.29	0.950%	99.1%	0%

Appendix F: Biogenesis Mass Balance Venice Pilot Demonstration

Batch 4: PC 1 CIO Upper Reach						
Process Stream	Centrifuge Stage Mass Balance					
Stream Number	Mass In		Mass Out			Mass Unaccounted For
Units	Sediment from Cavitation/Oxidation Chamber to Centrifuge	Effluent Water Storage/Treatment to Centrifuge	Centrifuge Solids	Centrifuge Centrate - Dissolved	Centrifuge Centrate - Solids Only	
Total Mass Input						
Percent Moisture						
Dry Weight Solids						
Water						
Source of Mass						
Source of Moisture Content						
Source of Chemical Info						
Other notes						
Metals	LBS	LBS	PCT	PCT	PCT	PCT
Arsenic	0.0822	0	265%	14.9%	897%	-1077%
Cadmium	0.0395	0	161%	176%	263%	-499%
Chromium (total)	0.158	0	129%	0.960%	214%	-244%
Copper	0.811	0	50.6%	0.823%	226%	-177%
Lead	0.353	0	214%	444%	718%	-1275%
Mercury	0.0447	0	56.0%	0%	208%	-164%
Nickel	0.0652	0	139%	37.2%	201%	-277%
Zinc	1.06	0	338%	398%	308%	-944%
Total (Sum of individual metals)						
Polyaromatic Hydrocarbons (PAHs)						
Naphthalene	0.0215	0	64.2%	0.0128%	5.23%	30.6%
Acenaphthylene	0.00619	0	113%	0.0445%	22.2%	-35.2%
Acenaphthene	0.00517	0	78.4%	0.0666%	35.7%	-14.2%
Fluorene	0.00376	0	97.2%	0.0732%	35.6%	-32.9%
Phenanthrene	0.0164	0	102%	0.0251%	37.5%	-39.4%
Anthracene	0.00568	0	173%	0.0484%	47.9%	-121%
Fluoranthene	0.0482	0	138%	0.0528%	81.8%	-120%
Pyrene	0.0332	0	122%	0.0352%	65.6%	-87.6%
Benz(a)anthracene	0.0126	0	211%	0.0438%	64.6%	-175%
Chrysene	0.0162	0	200%	0.0425%	47.1%	-147%
Benzo(b)fluoranthene	0.0187	0	78.5%	0.0221%	31.4%	-10.0%
Benzo(k)fluoranthene	0.0151	0	155%	0.0364%	28.1%	-83.1%
Benzo(a)pyrene	0.0110	0	158%	0%	39.1%	-97.0%
Indeno(1,2,3-cd)pyrene	0.00939	0	114%	0.0146%	24.2%	-38.3%
Dibenz(a,h)anthracene	0.00316	0	168%	0%	33.3%	-102%
Benzo(g,h,i)perylene	0.0170	0	75.8%	0.0122%	19.5%	4.63%
Total (as reported)	0.243	0	125%	0.0339%	46.3%	-71.8%
Total (Sum of individual compounds)						
Total Hydrocarbons						
Light Hydrocarbons (C < 12)						
Heavy Hydrocarbons (C > 12)						
Total	9.21	0	34.2%	0%	0%	65.8%

Appendix F: Biogenesis Mass Balance Venice Pilot Demonstration

Batch 4: PC 1 CIO Upper Reach			
Process Stream	Overall Efficiency		
Stream Number			
Units			
Total Mass Input			
Percent Moisture			
Dry Weight Solids	Mass Inputs	Mass Outputs	Efficiency
Water			
Source of Mass			
Source of Moisture Content			
Source of Chemical Info			
Other notes			
Metals	LBS	LBS	PCT
Arsenic	0.0975	0.983	-908%
Cadmium	0.0477	0.245	-413%
Chromium (total)	0.177	0.561	-217%
Copper	0.851	2.29	-169%
Lead	0.414	4.92	-1089%
Mercury	0.0454	0.119	-161%
Nickel	0.0765	0.257	-236%
Zinc	1.42	11.4	-708%
Total (Sum of individual metals)			
Polyaromatic Hydrocarbons (PAHs)			
Naphthalene	0.0219	0.0153	30.1%
Acenaphthylene	0.00624	0.00842	-34.9%
Acenaphthene	0.00521	0.00594	-14.1%
Fluorene	0.00380	0.00504	-32.6%
Phenanthrene	0.0166	0.0231	-39.0%
Anthracene	0.00575	0.0126	-120%
Fluoranthene	0.0490	0.107	-118%
Pyrene	0.0336	0.0627	-86.5%
Benz(a)anthracene	0.0127	0.0348	-173%
Chrysene	0.0164	0.0402	-145%
Benzo(b)fluoranthene	0.0190	0.0209	-9.84%
Benzo(k)fluoranthene	0.0153	0.0279	-82.1%
Benzo(a)pyrene	0.0111	0.0218	-95.6%
Indeno(1,2,3-cd)pyrene	0.00949	0.0131	-37.9%
Dibenz(a,h)anthracene	0.00320	0.00641	-100%
Benzo(g,h,i)perylene	0.0171	0.0163	4.60%
Total (as reported)	0.246	0.421	-70.9%
Total (Sum of individual compounds)	0.246		
Total Hydrocarbons			
Light Hydrocarbons (C < 12)			
Heavy Hydrocarbons (C > 12)			
Total	9.29	3.24	65.1%

Appendix F: Biogenesis Mass Balance Venice Pilot Demonstration

Batch 4: PC 1 CIO Upper Reach				
Process Stream	Decontamination Efficiency			
Stream Number	Raw Sediment Solids to Pre-Processor	Treated Sediment Removed by Hydrocyclone	Centrifuge Solids	Efficiency
Units				
Total Mass Input				
Percent Moisture				
Dry Weight Solids				
Water				
Source of Mass				
Source of Moisture Content				
Source of Chemical Info				
Other notes				
Metals	LBS	LBS	LBS	PCT
Arsenic	0.0975	0.0153	0.218	-139%
Cadmium	0.0477	0.00821	0.0635	-50.3%
Chromium (total)	0.177	0.0198	0.203	-25.8%
Copper	0.851	0.0399	0.411	47.0%
Lead	0.414	0.0604	0.755	-97.0%
Mercury	0.0454	0.000677	0.0250	43.4%
Nickel	0.0765	0.0113	0.0905	-33.1%
Zinc	1.42	0.354	3.59	-178%
Total (Sum of individual metals)				
Polyaromatic Hydrocarbons (PAHs)				
Naphthalene	0.0219	0.000339	0.0138	35.3%
Acenaphthylene	0.00624	0.0000513	0.00699	-12.8%
Acenaphthene	0.00521	0.0000411	0.00405	21.5%
Fluorene	0.00380	0.0000411	0.00365	2.73%
Phenanthrene	0.0166	0.000154	0.0168	-1.86%
Anthracene	0.00575	0.0000718	0.00985	-72.5%
Fluoranthene	0.0490	0.000831	0.0665	-37.4%
Pyrene	0.0336	0.000431	0.0405	-21.7%
Benz(a)anthracene	0.0127	0.000195	0.0264	-109%
Chrysene	0.0164	0.000257	0.0323	-98.2%
Benzo(b)fluoranthene	0.0190	0.000277	0.0147	21.2%
Benzo(k)fluoranthene	0.0153	0.000185	0.0234	-54.3%
Benzo(a)pyrene	0.0111	0.000154	0.0173	-57.0%
Indeno(1,2,3-cd)pyrene	0.00949	0.000103	0.0107	-14.0%
Dibenz(a,h)anthracene	0.00320	0.0000411	0.00532	-67.5%
Benzo(g,h,i)perylene	0.0171	0.000123	0.0129	24.0%
Total (as reported)	0.246	0.00329	0.305	-25.2%
Total (Sum of individual compounds)	0.246			
Total Hydrocarbons				
Light Hydrocarbons (C < 12)				
Heavy Hydrocarbons (C > 12)				
Total	9.29	0.0883	3.15	65.1%

REPORT DOCUMENTATION PAGE

Form Approved
OMB No. 0704-0188

Public reporting burden for this collection of information is estimated to average 1 hour per response, including the time for reviewing instructions, searching existing data sources, gathering and maintaining the data needed, and completing and reviewing this collection of information. Send comments regarding this burden estimate or any other aspect of this collection of information, including suggestions for reducing this burden to Department of Defense, Washington Headquarters Services, Directorate for Information Operations and Reports (0704-0188), 1215 Jefferson Davis Highway, Suite 1204, Arlington, VA 22202-4302. Respondents should be aware that notwithstanding any other provision of law, no person shall be subject to any penalty for failing to comply with a collection of information if it does not display a currently valid OMB control number. **PLEASE DO NOT RETURN YOUR FORM TO THE ABOVE ADDRESS.**

1. REPORT DATE (DD-MM-YYYY) March 2011		2. REPORT TYPE Final report		3. DATES COVERED (From - To)	
4. TITLE AND SUBTITLE Mass Balance, Beneficial Use Products, and Cost Comparisons of Four Sediment Treatment Technologies Near Commercialization				5a. CONTRACT NUMBER	
				5b. GRANT NUMBER	
				5c. PROGRAM ELEMENT NUMBER	
6. AUTHOR(S) Trudy J. Estes, Victor S. Magar, Daniel E. Averett, Nestor D. Soler, Tommy E. Myers, Eric J. Glisch and Damarys A. Acevedo				5d. PROJECT NUMBER	
				5e. TASK NUMBER	
				5f. WORK UNIT NUMBER	
7. PERFORMING ORGANIZATION NAME(S) AND ADDRESS(ES) Environmental Laboratory, U.S. Army Engineer Research and Development Center 3909 Halls Ferry Road, Vicksburg, MS 39180-6199; U.S. Army Engineer District, New Orleans 7400 Leake Avenue, New Orleans, LA 70118; (continued)				8. PERFORMING ORGANIZATION REPORT NUMBER ERDC/EL TR-11-1	
9. SPONSORING / MONITORING AGENCY NAME(S) AND ADDRESS(ES) Headquarters, U.S. Army Corps of Engineers Washington, DC 20314-1000 U.S. Environmental Protection Agency				10. SPONSOR/MONITOR'S ACRONYM(S)	
				11. SPONSOR/MONITOR'S REPORT NUMBER(S)	
12. DISTRIBUTION / AVAILABILITY STATEMENT Approved for public release; distribution is unlimited.					
13. SUPPLEMENTARY NOTES					
14. ABSTRACT The concept of contaminated sediment treatment producing a useful product has emerged in recent years, motivated by the cost of sediment disposal and by recognition of sediment as a resource rather than a waste. Contaminated sediment presents unique challenges for treatment, however, due to the character and complexity of the matrix, and the logistics and economics involved in coupling the process with a dredging operation. The objectives of this document are to capture the technical status of several promising treatment technologies of this type, to describe the process efficiency in terms of mass balance, to understand pre-treatment and post-treatment processing requirements, and to estimate full scale implementation costs at a scale compatible with a dredging operation. Overall, the document overlays a consistent and transparent structure on the comparative evaluation with the objective of providing an equivalent basis for comparison between these and other candidate treatment processes, such that it has utility of remediation to project managers and others engaged in technology selection efforts. Relying on publicly available demonstration reports, the following technologies were evaluated in depth: JCI/Upcycle rotary kiln thermal treatment/light-weight aggregate (LWA); Cement-Lock [®] technology/cement; Minergy [®] glass furnace technology/glass aggregate; and BioGenesis SM sediment washing process/manufactured soil.					
15. SUBJECT TERMS Beneficial use Biogenesis		Cement-Lok Contaminant sediment Dredged material		Mass balance Minergy Rotary Kiln (continued)	
16. SECURITY CLASSIFICATION OF:			17. LIMITATION OF ABSTRACT	18. NUMBER OF PAGES 285	19a. NAME OF RESPONSIBLE PERSON
a. REPORT UNCLASSIFIED	b. ABSTRACT UNCLASSIFIED	c. THIS PAGE UNCLASSIFIED			19b. TELEPHONE NUMBER (include area code)

7. PERFORMING ORGANIZATION NAME(S) AND ADDRESS(ES) (Continued)

ENVIRON International Corporation
333 West Wacker Drive, Suite 2700
Chicago, IL 60606-2872

15. SUBJECT TERMS

Sediment
Thermal
Treatment