

FINAL REPORT

Passive PE Sampling in Support of In Situ Remediation of Contaminated Sediments

ESTCP Project ER-200915

AUGUST 2015

Philip Gschwend
Massachusetts Institute of Technology

Kevin Palaia
ICF International

Distribution Statement A

This document has been cleared for public release



REPORT DOCUMENTATION PAGEForm Approved
OMB No. 0704-0188

Public reporting burden for this collection of information is estimated to average 1 hour per response, including the time for reviewing instructions, searching existing data sources, gathering and maintaining the data needed, and completing and reviewing this collection of information. Send comments regarding this burden estimate or any other aspect of this collection of information, including suggestions for reducing this burden to Department of Defense, Washington Headquarters Services, Directorate for Information Operations and Reports (0704-0188), 1215 Jefferson Davis Highway, Suite 1204, Arlington, VA 22202-4302. Respondents should be aware that notwithstanding any other provision of law, no person shall be subject to any penalty for failing to comply with a collection of information if it does not display a currently valid OMB control number. **PLEASE DO NOT RETURN YOUR FORM TO THE ABOVE ADDRESS.**

1. REPORT DATE (DD-MM-YYYY) 30-09-2014		2. REPORT TYPE		3. DATES COVERED (From - To)	
4. TITLE AND SUBTITLE Passive PE Sampling in Support of In Situ Remediation of Contaminated Sediments				5a. CONTRACT NUMBER W912HQ-09-C-0008	
				5b. GRANT NUMBER	
				5c. PROGRAM ELEMENT NUMBER	
6. AUTHOR(S) Philip M. Gschwend and Kevin J. Palaia				5d. PROJECT NUMBER ER-200915	
				5e. TASK NUMBER	
				5f. WORK UNIT NUMBER	
7. PERFORMING ORGANIZATION NAME(S) AND ADDRESS(ES) RM Parsons Laboratory 48-216G MIT Cambridge MA 02139 ----- ICF International 100 Cambridgepark Dr. Cambridge, MA 02140				8. PERFORMING ORGANIZATION REPORT NUMBER ER-200915	
9. SPONSORING / MONITORING AGENCY NAME(S) AND ADDRESS(ES) Environmental Security Technology Certification Program 4800 Mark Center Drive, Suite 17D08 Alexandria, VA 22350-3605				10. SPONSOR/MONITOR'S ACRONYM(S) ESTCP	
				11. SPONSOR/MONITOR'S REPORT NUMBER(S) ER-200915	
12. DISTRIBUTION / AVAILABILITY STATEMENT Approved for public release; distribution is unlimited.					
13. SUPPLEMENTARY NOTES					
14. ABSTRACT Our overarching goal was to show PE passive sampling is suited to assessing contaminated sediment sites. Hence, we sought to demonstrate: (a) PE effectively evaluates porewater concentrations of contaminants, (b) PE can delineate the horizontal and vertical extent of contamination, (c) PE is suited for long term monitoring, and (d) the PE passive sampling approach is commercially viable. Laboratory testing showed the PE samplers measured pore waters more accurately than the common commercial practice of using sediment concentrations. PE sampling readily revealed the distribution of sediment contamination by PCBs at the demonstration site. PE samplers showed the site had pg/L levels of individual PCBs in pore waters and bottom waters. Sand cap data indicated no upward PCB fluxes through those caps. Finally, QA/QC, sensitivity, ease of use, and cost metrics all supported the conclusion that PE passive sampling is commercially viable.					
15. SUBJECT TERMS polyethylene passive sampling, PCBs, sediments					
16. SECURITY CLASSIFICATION OF:			17. LIMITATION OF ABSTRACT	18. NUMBER OF PAGES	19a. NAME OF RESPONSIBLE PERSON
a. REPORT	b. ABSTRACT	c. THIS PAGE			Phil Gshwend
				87	19b. TELEPHONE NUMBER (include area code) 617-253-1638

Table of Contents

	page
EXECUTIVE SUMMARY	1
1.0 INTRODUCTION	2
1.1 Background.....	3
1.2 Objective of the Demonstration.....	3
1.3 Regulatory Drivers.....	3
2.0 TECHNOLOGY	4
2.1 Technology Description.....	4
2.2 Technology Development.....	5
2.3. Advantages and Limitations of the Technology	8
3.0 PERFORMANCE OBJECTIVES	8
3.1 Performance Objective: Demonstrate PE Passive Sampling Accurately Provide Measures of Porewater Concentrations.....	10
3.2 Performance Objective: Demonstrate PE Passive Sampling Is Effective for Site Mapping.....	10
3.3 Performance Objective: Demonstrate PE Passive Sampling Is Suited to Long Term Monitoring (LTM) After Site Remediation.....	11
3.4 Performance Objective: Demonstrate PE Passive Sampling Commercially Viable Based on QA/QC Metrics, Ease of Use, and Costs	11
4.0 SITE DESCRIPTION	12
4.1 Site Location and History	12
4.2 Site Geology/Hydrogeology	13
4.3 Contaminant Distribution.....	14
5.0 TEST DESIGN.....	15
5.1 Conceptual Experimental Design	15
5.2 Baseline Characterization Activities.....	15
5.3 Laboratory Study Results.....	16
5.4 Field Testing	19
5.5 Sampling Methods.....	20
6.0 PERFORMANCE ASSESSMENT	23
6.1 Performance Objective: Demonstrate PE Passive Sampling Accurately Provide Measures of Porewater Concentrations.....	23
6.2 Performance Objective: Demonstrate PE Passive Sampling Is Effective for Site Mapping.....	28
6.3 Performance Objective: Demonstrate PE Passive Sampling Is Suited to Long Term Monitoring (LTM) After Site Remediation.....	32
6.4 Performance Objective: Demonstrate PE Passive Sampling Commercially Viable Based on QA/QC Metrics, Ease of Use, and Costs	34
7.0 COST ASSESSMENT	36
7.1 Cost Model.....	36
7.2 Cost Drivers	38
7.3 Cost Analysis.....	40
7.4 Cost Assessment Summary.....	44
8.0 IMPLEMENTATION ISSUES	45
9.0 REFERENCES	45

APPENDICES

Appendix A: Points of Contact.....	48
Appendix B: Standard Operating Procedures.....	49
Appendix C. Seasonal variations in groundwater pumping near Pegan Cove in 2010 and 2011.....	71
Appendix D. Station Locations.....	72
Appendix E. Organic carbon (f_{oc}) and black carbon (f_{bc}) weight percent results for sediments recovered in the first sampling round. f_{oc} values averaged near 14% by weight and black carbon contents averaged 1% by weight.....	74
Appendix F. Minimum detection limits for five individual PCB congeners (#28, 52, 101, 153, and 180) determined by analyzing low levels in 10 PE strips. Assuming PE strip mass is 100 mg, the extract volume is 100 uL, and using PE-water partition coefficients from Lohmann (2012), these results imply porewater detections are below 1 pg/L for individual congeners if the PE is equilibrated with the porewater; more uncertainty associated with PRC corrections will cause these minimum detection limits to go up for <i>in situ</i> deployments where PE-porewater equilibration cannot be assumed.....	75
Appendix G. Comparisons of Pace and MIT measures of four PCB congeners (52, 101, 153, and 180) in sediments from two sites in Pegan Cove (stations 1 and 8) after spiking at four different levels.....	76
Appendix H. Detailed Cost Comparison of PE Sampling versus Traditional Ponar Dredge Sampling Techniques.....	77
Tables	
Table 1. Performance objectives.....	8
Table 2. Field sampling performed in this project.....	15
Table 3. Testing method reproducibility using <i>ex situ</i> replicate testing of PCB porewater concentrations (ng/L) found using PE passive samplers in homogenized field sediments AFTER applying corrections using PRCs.....	18
Table 4. Total number and types of samples collected.....	22
Table 5. Analytical methods for sample analyses.....	23

Table 6. List of ¹³C-labeled PCB congeners used as performance recovery standards in this study. Also show are the log K_{ow} values from Hawker and Connell (1988) and the log K_{pew} values estimated from log K_{pew} = log K_{ow} – 0.287 from Gschwend et al.. (2011).....23

Table 7. Estimated porewater concentrations for the sum of nine PCB congeners using four approaches (Apell and Gschwend, 2014).....28

Table 8. Cost comparison of PE samplers and traditional sediment sampling technique.....40

Figures

Figure 1. PCB congener #52 chemical activities at a DoD site (shown as water concentrations that would be in equilibrium with each medium).....2

Figure 2. A PE sampler just after retrieval from the sediment of Lake Cochituate (the demonstration site used for this study) where it had been left for a month.....4

Figure 3. Creation of a polyethylene passive sampling device using aluminum sheet metal cut into two frames (blue) so as to "sandwich" a strip of PRC-loaded PE (red). The PED allows the 5-cm wide by 50-cm long PE strip to be exposed to the sediment and bottom water on both sides by holding it in a window in the frames (drawing by ICF International).....6

Figure 4. Illustrations of polyethylene strips mounted in aluminum sheet metal frames for field deployments into sediment beds.....7

Figure 5. Map showing location of the study area, Pegan Cove, within Lake Cochituate and adjacent to the U.S. Army Natick Soldier Systems Center (NSSC).....12

Figure 6. Zone of influence (white circle) of water supply wells located northwest of Pegan Cove (shown in lower right of lake).....13

Figure 7. Distribution of PCBs (mg/kg) in the sediments of Pegan Cove.....14

Figure 8. (left) Map of 20 stations distributed in Pegan Cove, Lake Cochituate. Note that 2009 samples (red points and nos. 1-10) were taken before dredging, while 2010 samples (blue points and nos. 11-20) were taken after dredging which was done in areas indicated by yellow and green shading. (right) Sediment porosities (volume fractions), organic carbon contents (weight fractions), and ΣPCBs (mg/kg dw) are shown for each station; note stations 17, 18, 19, and 20 were located on the corners of square that was 10 m on a side. Stations 2 and 4 were located at near-shore sandy locations and had distinctly lower porosities and organic carbon contents (f_{oc}).....17

Figure 9. Comparison of porewater concentrations of three PCB congeners (nos. 52, 101, 153) measured using PE passive samplers (red bars) versus traditional porewater isolation and extraction after removing colloids via alum precipitation (blue bars) for sediments collected at 18 different sites in the demonstration area.....19

Figure 10. Comparison of individual PCB congener concentrations found by direct extraction of pore water samples from 18 stations with values deduced using passive PE sampling (filled circles: $(C_{PE}/K_{pe-water}) = (0.53 \pm 0.8) C_{porewater} + 0.048 \pm 0.014$) and using sediment concentrations (open circles: $(C_{sediment}/f_{oc}K_{oc}) = (4.6 \pm 1.7) C_{porewater} + 0.35 \pm 0.29$).....20

Figure 11. Illustration of the sequence of steps used to prepare, deploy, and analyze PE passive samplers.....21

Figure 12. Screen shot from the PRC Correction Calculator showing (upper left) an example of data entry for measured PRC losses, sampler deployment time, PE film thickness, and sediment porosity, and (lower right) fitted fractions of equilibration for target compounds of interest and the goodness of fit of the PRC data to the $\log K_d$ versus $\log K_{ow}$ relation.....24

Figure 13. Comparisons between *ex situ* PE-sampler inferred concentrations using homogenized sediments and PRC corrections with concentrations found by exhaustively mixing PE with lake sediments ("tumbling") in the laboratory until the PCBs in the sediment equilibrated with the PE (Apell and Gschwend 2014). All PCB target compounds were between PRCs in terms of size causing all corrections to involve interpolations.....25

Figure 14. PCB porewater concentrations measured using PE passive samplers (filled circles) were consistently lower when measured in sediments: (left) after their return to the laboratory and (right) in the field (i.e., *in situ*).....25

Figure 15. (left) Map of 7 additional stations (black circles with nos. between 21 and 39) in Pegan Cove, Lake Cochituate, tested with *in situ* PE samplers in May-June 2011. Porosities (volume fractions), organic carbon contents (weight fractions), and Σ PCBs (in mg/kg dry weight) are also shown.....26

Figure 16. Porewater concentrations of four PCB congeners: 52 (black), 101 (red), 153 (blue), and 180 (green) in seven different sediments from Lake Cochituate, Natick MA measured in laboratory-tumbled polyethylene pieces and in extracted porewater (Apell and Gschwend 2014). The polyethylene measurements were converted to porewater concentrations using K_{PEw} values. The solid line represents the 1:1 relationship and the dashed lines represent the calculated root mean square error of 0.23..... 27

Figure 17. Porewater concentrations deduced from the equilibrated PE (dashed line) compared with (a) the passive sampling results (squares), (b) the equilibrium partitioning model accounting for only organic carbon (x) and (c) the equilibrium partitioning model accounting for both organic and black carbon (*). Figure from Apell and Gschwend (2014).....28

Figure 18. Comparison of maps of total PCB concentrations from (left) sediment concentrations (mg/kg dry weight) measured from 50 samples before dredging at the site began and (right) porewater concentrations (ng/L porewater) obtained using results from 18 *in situ* PE passive samplers obtained during round 3 of this project after targeted dredging (see Figure 8 yellow and

green areas). The highest sediment concentration contours encompass areas (indicated in red on left panel) with more than 2.5 mg Σ PCBs/kg sediment, while the highest porewater concentration contours at more than 1 ng Σ PCBs/L porewater highlight the most contaminated areas (indicated in red on right panel).....29

Figure 19. Contour maps of Σ PCBs from data obtained in sampling rounds 1 and 2 indicating PCB concentrations in sediments based on: (left) direct analysis of C_{sediment} (contour shown separates >2 ppm from 1 – 2 ppm areas), (middle) direct analyses of porewater samples which are subsequently used to estimate sediment concentrations by $f_{oc}K_{oc} \times C_{\text{porewater}}$ (contour shown separates >0.25-0.5 ppm from <0.25 ppm areas), and (right) indirect estimation of porewater concentrations using PE passive sampling ($C_{\text{porewater}} = C_{\text{PE}}/K_{\text{PEw}}$) and then estimating sediment concentrations by $f_{oc}K_{oc} \times C_{\text{PE}}/K_{\text{PEw}}$. If porewater concentrations reflect "bioavailable" portions of sediment concentrations, then one may readily see stark differences between use of total sediment concentrations as opposed to sediment concentrations deduced from porewater concentration information.....30

Figure 20. PE uptake profiles of four PCB congeners (52, 101, 153, and 180) acquired by *in situ* PE passive sampling of four locations located at the corners of a square that was 10 m on a side.....31

Figure 21. PE uptake profiles for four congeners (52, 101, 153, and 180) acquired by *in situ* PE passive sampling at four locations in Pegan Cove.....32

Figure 22. Results for PCB 101 using *in situ* PE passive samplers for long term monitoring at the Pegan Cove site. Each profile is co-plotted with results from the fall of 2012 (diamonds). Also note that results above depth = 0 represent the bottom water concentrations.....33

Figure 23. *In situ* PE passive sampling observations through sand caps at Pegan Cove in sampling round 3 (June 2011), sampling round 4 (November 2011), and sampling round 6 (November 2012). Red lines indicate location of bed-bottom water interface, while black line indicates putative bottom of the sand cap.....34

Acronyms/Abbreviations/Symbols

BC	black carbon
C_{PE}	concentration of HOC in PE (e.g., $\mu\text{g}_{\text{HOC}}/\text{g}_{\text{PE}}$)
$C_{\text{pore water}}$	concentration of HOC in pore water (e.g., $\mu\text{g}_{\text{HOC}}/\text{mL}_{\text{pore water}}$)
C_{sediment}	concentration of HOC in dry sediment (e.g., $\mu\text{g}_{\text{HOC}}/\text{g}_{\text{sediment}}$)
CERCLA	Comprehensive Environmental Response, Compensation, and Liability Act
DCM	dichloromethane
DoD	Department of Defense
ECD	electron capture detector
EPA	Environmental Protection Agency
EqP	equilibrium partitioning model
ESTCP	Environmental Security Technology Certification Program
f_{oc}	organic carbon weight fraction in sediment ($\text{g}_{\text{organic carbon}}/\text{g}_{\text{sediment}}$)
GC/MS	gas chromatography/mass spectrometry

HOCs	hydrophobic organic compounds
IDW	investigation-derived waste
K_d	sediment-water partition coefficient (e.g., mL _{water} /g _{sediment})
K_{oc}	organic carbon normalized sorption coefficient (mL _{water} /g _{organic carbon})
K_{PEw}	PE-water partition coefficient (e.g., mL _{water} /g _{PE})
LDPE	low density polyethylene
LTM	long term monitoring
MDL	method detection limit
NPL	National Priorities List
NSSC	U.S. Army Natick Soldier Systems Center
PAHs	polycyclic aromatic hydrocarbons
PCBs	polychlorinated biphenyls
PE	polyethylene
PED	polyethylene device
PPE	personal protection equipment
PRCs	performance reference compounds
PRPs	potentially responsible parties
QA/QC	quality assurance/quality control
RPD	relative percent difference
RSD	relative standard deviation
SERDP	Strategic Environmental Research and Development Program
SOPs	standard operating procedures

Acknowledgments

Several colleagues were instrumental in accomplishing this project. At MIT, Elizabeth Follett, Jennifer Apell, and John MacFarlane were responsible for PE sampler preparations, analysis of PE, pore water, and sediments for PCBs, and data processing and interpretations. A. Patricia Tcaciuc developed the PRC Correction Matlab routine and Daniel Prendergast helped in the field and the laboratory.

Meanwhile, at ICF International, Dean Gouveia provided critiques concerning analytical chemistry and regulatory issues and Steve Reichenbacher accomplished the several rounds of field sampling and much of the cost analysis. Finally, James Connolly of the US Army Natick Soldier Systems Center provided logistical support at the demonstration site and critiqued the work from the point of view of the client (i.e., DoD).

We also gratefully acknowledge the support of the ESTCP program funded through support from the U.S. Army Corps of Engineers, Humphreys Engineer Center Support Activity under Contract No. W912HQ-09-C-0008. This material is also based upon work supported by the National Science Foundation Graduate Research Fellowship under Grant No. 1122374. Any opinion, findings, and conclusions or recommendations expressed in this material are those of the authors and do not necessarily reflect the views of the National Science Foundation and should not be construed as an official Department of Defense position or decision unless so designated by other official documentation.

EXECUTIVE SUMMARY

The overarching goal of this work was to show PE passive sampling is suited to assessing contaminated sediment sites. To this end, we sought to demonstrate: (a) the PE technology effectively evaluates concentrations of target contaminants in pore water, (b) PE be used to delineate the horizontal and vertical extents of sediment contamination, (c) PE sampling is suited for long term monitoring, and (d) the PE passive sampling approach is commercially viable. Laboratory testing showed the PE samplers measured pore waters much more accurately than the common commercial practice of using sediment concentration data. Moreover, the PE data readily revealed the extent PCB contamination at the demonstration, both laterally and with depth into the sediment bed. Also the PE samplers showed the site has exhibited pictogram per liter levels of individual PCBs in pore the uppermost pore waters and the site's bottom waters for the past 3 years. Observations made in sand caps used at the site indicate no upward fluxes of PCBs through those caps, although the PE sampler results also lead us to recognize significant downward flow of lake water into the bed at the site. Finally, QA/QC, sensitivity, ease of use, and cost metrics were all supportive of the conclusion that the PE passive sampling approach is commercially viable. The chief remaining obstacle to widespread use of this site evaluation approach involves interfacing pre water concentration data with currently available regulatory standards.

1.0 INTRODUCTION

Hydrophobic organic compounds (HOCs) like polychlorinated biphenyls (PCBs) and polycyclic aromatic hydrocarbons (PAHs) contaminate sediments at many Department of Defense (DoD) sites. Assessment requires expensive field sampling campaigns and laboratory analyses. High costs are driven by the need to obtain enough samples to define the scope of the problem, characterize risks, and to overcome analytical difficulties arising from complex mixtures. Composite samples reduce costs; but they also reduce our understanding of the site, potentially even masking “hot spots”. Designing and implementing successful *in situ* remediation requires knowledge of the vertical and horizontal extent of contamination to ensure sufficient remediation of the problem area, while not expending resources on acceptable sediments.

Research has shown the inaccuracy of using sediment concentrations to infer exposures of receptors and corresponding risks. For example, at the DoD site used as a demonstration site in this study, one finds that sediment concentrations of PCBs (e.g., congener #52), when normalized by the sediment organic carbon content (f_{oc}) as recommended by EPA's equilibrium partitioning (EqP) approach (DiToro et al., 1991), cause one to estimate very high porewater concentrations (e.g. 5000 pg/L for congener #52, Figure 1). This exposure level would cause to high shellfish and finfish tissue levels if these organisms were equilibrated with such porewater. But measurements of this PCB congener's concentrations in the organisms only correspond to levels equilibrated with lake water at 9-60 pg/L. We suspect that the EqP approach fails, at least in part, because it does not consider soots and chars (together called black carbon or BC) that are now known to be in all sediments (e.g., Gustafsson et al., 1997; Cornelissen et al., 2005). Sorption of PCB congener #52 to such BC at this site would certainly lower the expected body burdens. However, evaluating the effects of such combustion-derived BC still involves substantial uncertainty with respect to the BC-normalized sorption coefficients.

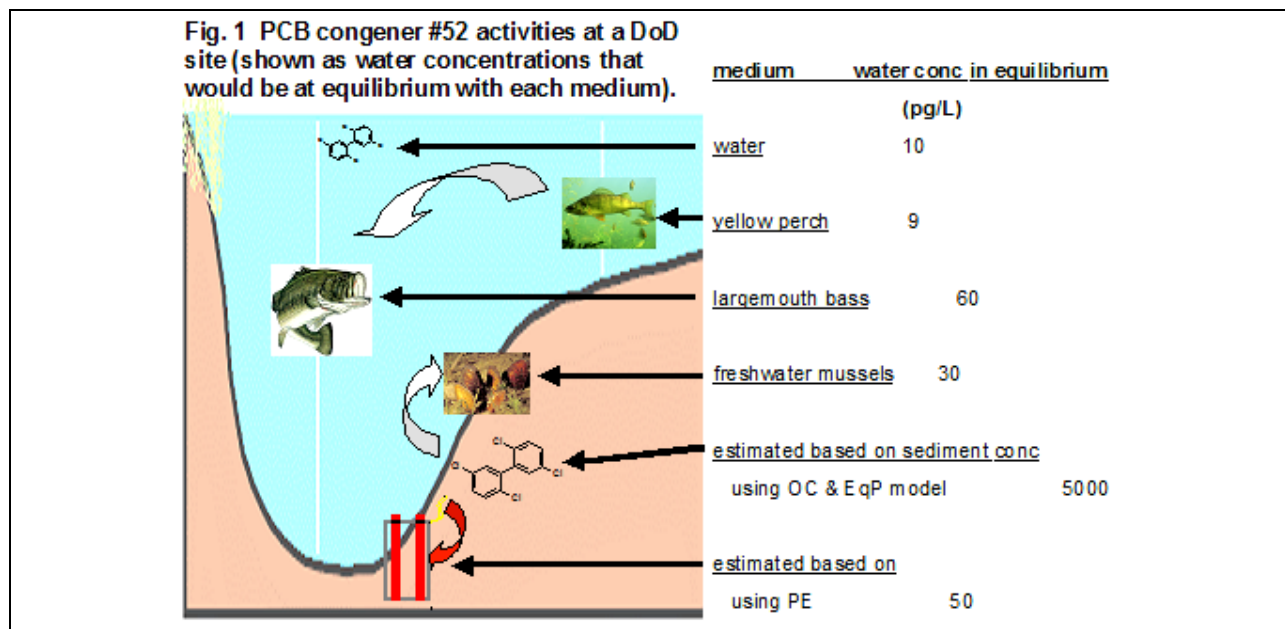

1.1 BACKGROUND

One way to circumvent the problem of using sediment concentrations to estimate organism exposures would be to use passive samplers. Such samplers accumulate contaminants from the environmental matrix in proportion to the chemical activities in the sampled medium (Huckins et al., 1990; Arthur and Pawliszyn, 1990). Hence, we proposed that polyethylene (PE) passive samplers, inserted directly in the sediment bed, could reveal the availability of contaminants like PCBs to accumulate in proportion to those compounds' "bioavailabilities". Preliminary application of such PE samplers in sediments and the lake water from the same DoD site mentioned above (and used as the demonstration site of this project) revealed PE-derived measures of congener #52 of 50 pg/L_{pore water} and 10 pg/L_{overlying water}, remarkably similar to levels seen in the organisms that appear to reflect equilibration with water concentrations of 9, 60, and 50 pg/L_{water} (Figure 1). Clearly, there was much better correspondence between the observed PCB body burdens in the fish and shellfish and what one infers from the PE samplers.

Moreover, we proposed that PE passive sampling can enable easier, safer, and more cost effective collection of samples and simplification of the analyses in complex matrices. This will allow better problem delineation and enable effective use to monitor long term changes associated with *in situ* remediation.

1.2 OBJECTIVE OF THE DEMONSTRATION

The overall objective of this study was to demonstrate that PE passive sampling is a commercially viable technology that is well suited to determining horizontal and vertical distributions of HOCs in sediments for purposes of assessing *in situ* remediation and/or long term monitoring (LTM). Our specific objectives included:

- a) Demonstrating the PE technology effectively evaluates mobile and bioavailable concentrations of target HOCs comparable to direct pore water assessment.
- b) Demonstrating that PE passive sampling can define the horizontal and vertical extents of sediment contamination.
- c) Demonstrating that PE sampling is suited for LTM programs.
- d) Establishing commercial viability of PE sampling and analysis, including establishing costs and analytical metrics such as accuracy, precision, and limits of detection.

1.3 REGULATORY DRIVERS

Regulatory goals typically involve limiting human and ecosystem risks associated with exposures to contaminants. Therefore, most regulatory management decisions associated with contaminated water bodies are made using risk-based evaluations of sediment and/or fish concentrations. We recognize that the ultimate risk to human and ecological receptors is based on more than just exposure estimates; but for sources such as contaminated sediments, these risks are best evaluated using metrics related to sediment porewater concentrations. It is critically important to fully understand the mechanisms in which HOCs, such as PCBs, bioaccumulate in the food web. The PE technology enhances the understanding of what role porewater

concentrations play in the contaminant uptake system, and bring regulators and PRPs to more common ground.

The PE passive sampling methodology and PE-derived data must therefore be capable of being used in risk calculations. While PE results may not be a replacement for sediment concentrations in the short term, if the method allows site managers to more quickly and cost-effectively delineate areas of concern, it might become acceptable to regulators as a valid tool to make more well-informed decisions throughout the risk management process. Hence, it will be our goal to demonstrate that PE-derived data will meet the needs of site managers in this regard.

2.0 TECHNOLOGY

2.1 TECHNOLOGY DESCRIPTION

The PE passive sampling approach utilizes an inert medium, low density polyethylene (LDPE, Figure 2), to accumulate organic contaminants from contaminated sediment beds (or overlying waters) to an extent that reflects the relevant concentrations that drive chemical transport, bioaccumulation, and biodegradation. As discussed in Fernandez et al. (2009b), target compounds like PCBs and PAHs diffuse through the surrounding environmental media, partition into the polyethylene, and then continue to diffuse into the PE film until the accumulated concentrations are equilibrated with the environment in which they were placed. Since, in practice, investigators often cannot leave the sampler exposed in sediments long enough to achieve partitioning equilibration, it is recommended that internal standards called performance reference compounds (PRCs) be impregnated in the PE films before they are deployed. And since the PRCs experience the same mass transfer limitations while diffusing out of the PE as the

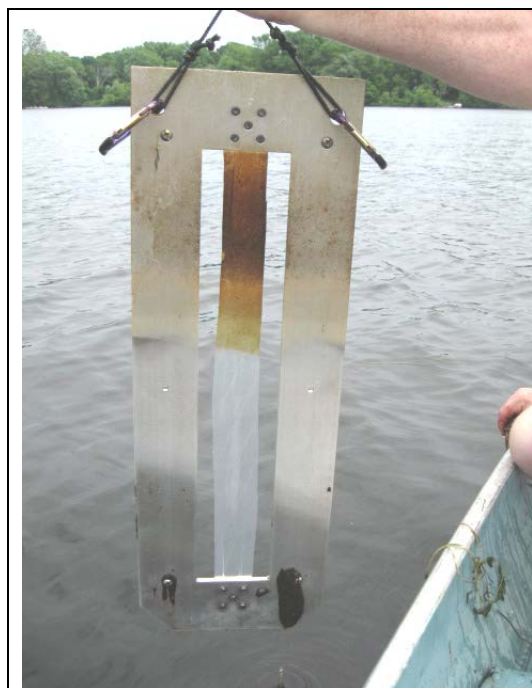

Figure 2. A PE sampler just after retrieval from the sediment of Lake Cochituate (the demonstration site used for this study) where it had been left for a month. The PE strip is 50 cm long and 5 cm wide, and it is held in an aluminum sheet metal frame. The upper section of the PE is brownish due to biofilm growth on it; the lower portion is clear where the PE was incubated in the lake's sediment bed.

target compounds that are diffusing into the PE, one can use the measured losses of the PRCs to also know the fractional approaches to equilibrium of the target compounds (Fernandez et al. 2009b, Apell and Gschwend, 2014). Using this result, the concentrations of target compounds accumulated in the PE during the finite deployment time can be corrected to the levels they would have achieved at equilibrium. Finally, this equilibrium concentration can be normalized with independently known polyethylene-water partition coefficients, K_{PEw} 's, to find the corresponding porewater concentrations of the contaminants of interest.

2.2 TECHNOLOGY DEVELOPMENT

The MIT group previously worked for 3 years to develop the PE-based passive sampling approach with SERDP support (ER-1496). In general, those efforts have focused on PAHs in Boston Harbor sediments (Fernandez et al. 2009a,b). The PE samplers have also been used to assess PCBs in Hunters Point, San Francisco Bay sediments in a multi-lab inter-comparison effort (Gschwend et al., 2011). Multi-day and multi-week PE deployments in both Boston and New York harbors have shown we can readily quantify PAHs, PCBs, and dioxins in the water and the beds at those sites (Lohmann et al., 2004, Adams et al., 2007). In particular, efforts have focused on the use of PRCs to quantify accurately a wider range of target contaminants (Fernandez et al., 2009b; Apell and Gschwend, 2014).

The following describes details of the methods, but more information can be found in the on-line guidance documents (Gschwend et al., 2012a, 2012b, and 2012c). The polyethylene (PE) is purchased from hardware/painting stores in large sheets ('dropcloth or plastic tarp' material) with a thickness of 25 μm (1 mil) or 51 μm (2 mil), depending on the user's need for strength (choose thicker) and desire to use short deployment times (use thinner). The sheet is cut into strips sized for the environment and the support frames to be used. An organic solvent cleaning sequence is used to prepare the PE. This process ensures that extractable oligomers, plasticizers, and contaminating organic chemicals are removed from the PE prior to use. PRCs are loaded into the clean PE, prior to its field deployment, by utilizing either aqueous (Fernandez et al. 2009a) or 80:20 methanol-water equilibrations (Booij et al., 2002). PRC loading is performed by placing the PE in pre-cleaned glass vessels containing known PRC solutions made up in organic-free reagent water with or without pesticide-grade methanol. The PE user should estimate the expected accumulation of target compounds in the passive sampler and seek to load with similar levels of PRCs to facilitate the eventual chemical analyses. PRC equilibration time is typically ≥ 1 month for loading from water and ≥ 1 week for loading from methanol-water to ensure uniform PE loading across the entire PE thickness. For PE loaded from water solutions, the PE is stored in the PRC solutions until just before field use; for PE loaded from methanol-water solutions, the PRC-loaded PE is rinsed with ultrapure water, and then it is soaked in ultrapure water for 24 hours to remove methanol from the PE. This methanol leaching step is repeated twice to insure complete methanol removal. Finally, PE is stored in this last leaching solution until just before its field use.

Just before field deployments, the PRC-loaded PE sheets are mounted in rigid, aluminum, sheet metal frames creating a polyethylene device (PED, Figure 3). Bolts or sheet metal screws are used to hold the PE stretched out in the frame. Commonly, it is useful to put white tape on the

Figure 3. Creation of a PE passive sampling device using aluminum sheet metal cut into two frames (blue) so as to "sandwich" a strip of PRC-loaded PE (red). The resultant polyethylene device (PED allows the 5-cm wide by 50-cm long PE strip to be exposed to the sediment and bottom water on both sides by holding it in a window in the frames (drawing by ICF International).

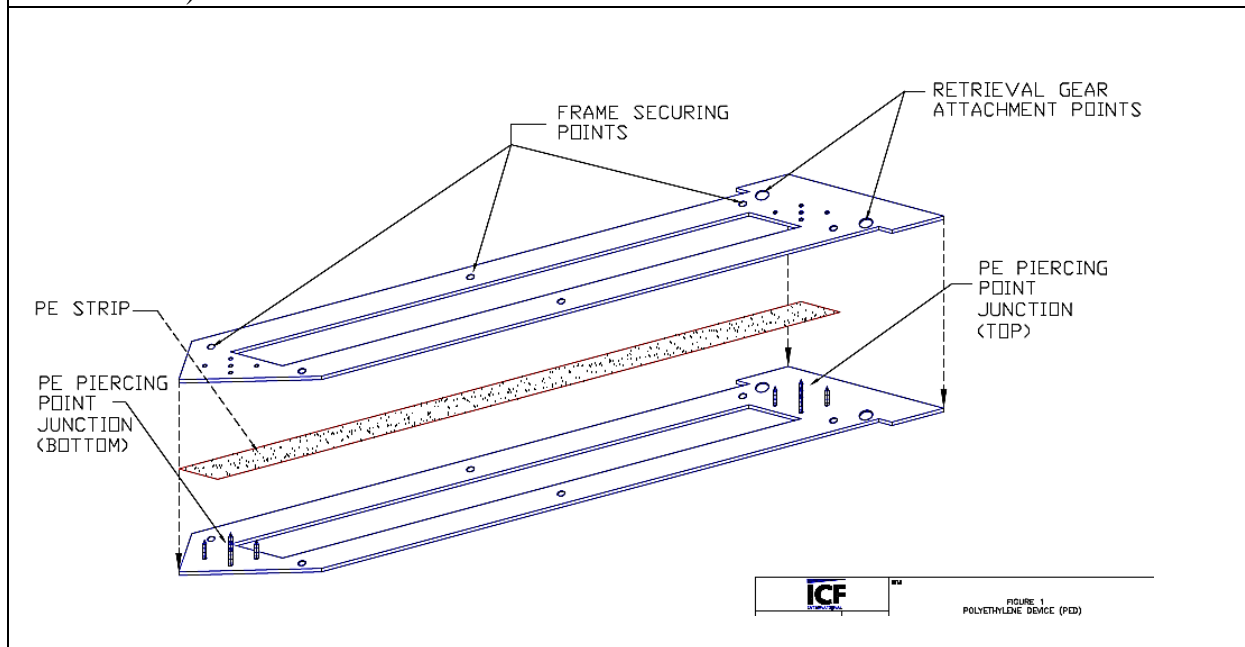

aluminum frame to indicate the desired depth to which the sampler should be inserted in the sediment bed.

Such samplers can be deployed (a) in shallow waters by hand, (b) at modest depths (<5 m) using a pole with a releasing mechanism, (c) in deeper waters by divers (5-20 m), and (d) in still deeper sites using a frame lowered from a boat (Figure 4). Samplers are marked with buoys or tag lines to facilitate their later recoveries.

After the desired deployment period, samplers are recovered (e.g., tag lines, Figure 2), rinsed of any adhering mud, wrapped in clean aluminum foil, and placed in clean storage (e.g., an ice chest without ice in it). Upon return to the lab, the PE surface is cleaned with a water-wetted Kimwipe® and cut into meaningful sections (e.g., to obtain replicates or to acquire sections exposed to varying depths into a sediment bed). The PE pieces, usually 10 to 100 milligram masses, are placed in pre-cleaned, amber glass vials, spiked with method recovery standards, and submerged in methylene chloride for at least 12 h. The extract is transferred to a large volume concentration vessel, and then the PE is re-extracted two more times in methylene chloride and the extracts combined. After extraction, the PE is air-dried and weighed. PE extracts are concentrated using rotary evaporation (or equivalent) down to suitable volumes for GC/MS analysis. Before analysis, appropriate injection standards are added to allow for evaluation of the fraction of extract volume analyzed.

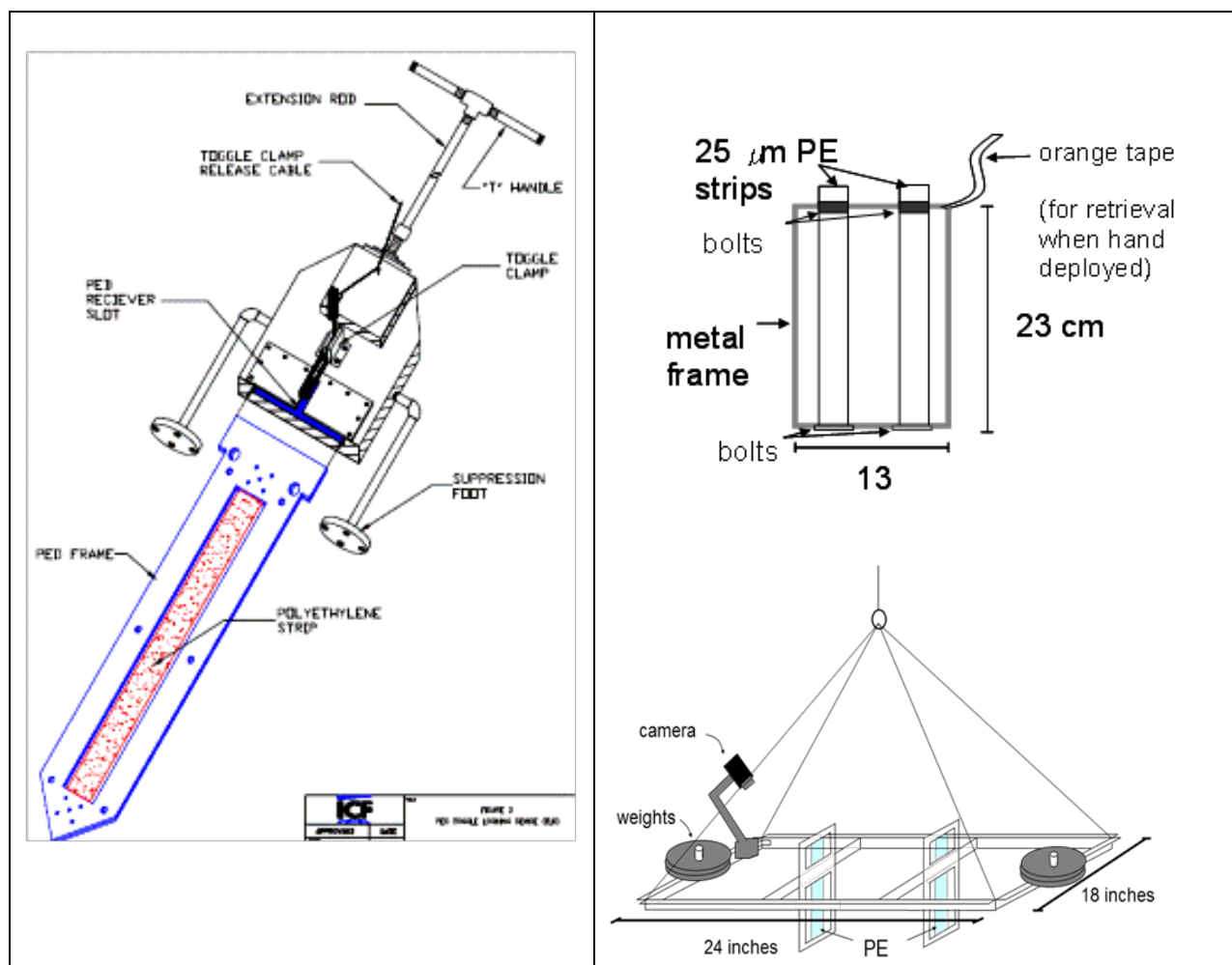

Figure 4. Illustrations of PE strips mounted in aluminum sheet metal frames for field deployments into sediment beds.

The left panel shows a larger sampler (~50 cm vertical opening) which can be inserted into the sediment beds using a releasable extension rod that can reach about 5 m deep while standing on a boat. The suppression feet insure positioning of the sampler at a known depth across the sediment-water interface. A line is attached to the toggle clamp to release the sampler from the deployment hardware after insertion into the sediment bed.

The right panel shows a shorter sampler (vertical opening ~20 cm) suited to hand deployment in shallow/tidal locations or for mounting on a weighted frame that can be lowered from a vessel in deeper water.

Using the PRC recovery data in each case, the sediment-equilibrated target compound concentrations in the PE are calculated. A graphic user interface called the "PRC Correction Calculator" has been developed to assist such calculations (Tcaciuc et al., 2014). Using the corresponding PE-water partition coefficients (also given in the PRC Correction Calculator), each contaminant's porewater concentration is calculated.

2.3 ADVANTAGES AND LIMITATIONS OF THE TECHNOLOGY

PE passive sampling offers several advantages. It yield data that reveal: (1) vertical HOC concentration variations at cm scales (e.g., indicating burial of previously contaminated sediment), (2) sediment bed-water column concentration gradients enabling estimation of continuing contamination fluxes to overlying ecosystems, and (3) bioavailable contaminant levels needed to evaluate prospective bioaccumulation and biodegradation. The PE passive sampling technique may also offer significant cost savings per site for sample collection and analysis cost. When compared with traditional sediment site characterization techniques, the PE method provides a cost reduction in manpower, equipment and shipping costs, investigation-derived waste (IDW) costs. Also it is overall a safer procedure when compared to traditional sediment sampling techniques.

Limitations may include: (1) the resultant data are not yet accepted by all regulators, (2) current samplers may require “prolonged” deployments (≥ 2 month) to assess some HOCs (e.g., highly chlorinated PCB congeners), (3) difficulties of deploying the PE in sediment bed materials encountered at some sites (e.g., rocky substrates), and (4) obtaining a reasonable deployment time that will not present an obstacle to a cost-effective deployment/retrieval program and avoid sampler losses during deployment due to vandalism, exposures to strong propeller wash, or as a consequence of extreme weather events.

3.0 PERFORMANCE OBJECTIVES

Performance objectives for this project were chosen to demonstrate (a) the accuracy of this new approach for assessing HOC-contaminated sediment beds, (b) the ability to use passive sampling data for site mapping, (c) the usefulness of the method for carrying out long-term monitoring (LTM) of HOC contaminants, (d) the ease and cost-effectiveness of using such passive sampling methods, and (e) the commercial viability of this passive sampling approach.

Performance Objective	Data Requirements	Success Criteria	Results
1. Demonstrate PE Passive Sampling Accurately Provides Measures of Porewater Concentrations	Using numerous sediment locations, contrast traditional procedures for obtaining porewater concentrations (porewater extraction and analysis; normalization of sediment concentrations by $f_{oc}K_{oc}$) with results obtained via PE passive samplers.	<ul style="list-style-type: none"> average relative percent difference (RPD) of -50% / +100% or less (i.e., \leq factor of 2) 	<ul style="list-style-type: none"> replicate analyses using PE yielded mean \pm std. dev. results that are indistinguishable from porewater extractions. PE sampling of sediments from many sites for individual PCB congeners yielded results that were $79 \pm 47\%$ (N=60) of results obtained by porewater extractions use of sediment concentrations resulted in porewater estimates that were 5x greater than porewater extractions and PE measures.

<p>2. Demonstrate PE Passive Sampling Is Effective for Site Mapping.</p>	<p>Spatially-distributed array of samples suited to PCB contouring in 3-D.</p>	<ul style="list-style-type: none"> • Lower uncertainty value in areal delineation • Cost for PE sampler approach less or comparable to traditional sampling and analysis 	<ul style="list-style-type: none"> • accuracy of PE results implies better delineation of contamination than obtained with sediment results • cost for PE use about same as current practice of collecting and analyzing sediments
<p>3. Demonstrate PE Passive Sampling Is Suited to Long Term Monitoring (LTM) After Site Remediation</p>	<p>Obtain PE passive sampler data that reflect spatial and temporal changes in PCB presence in sediments and water at the site</p>	<p>Regulator acceptance</p>	<ul style="list-style-type: none"> • PE data collected annually and as a function of depth into sediment bed shows little or no change in porewater concentrations • NOTE: demo' site experiences strong infiltration rates into the bed, complicating vertical profile interpretations • LTM at demonstration site only just beginning
<p>4. Demonstrate PE Passive Sampling Commercially Viable Based on QA/QC Metrics, Ease of Use, and Costs</p>	<p>Develop method QA/QC limits comparable for industry standards</p> <p>Establish basis for a minimum detection limit and quantitation limit reflecting levels below thresholds that correspond to unacceptable health risks</p> <p>PE passive sampler use feasible for use by regulators, environmental consulting companies, and contract labs</p> <p>Costs of time and materials needed for PE passive sampling and traditional sampling of PCBs at same site</p>	<p>Accuracy, precision, and MDLs using PE are comparable to or better than those found using accepted porewater analyses procedures</p> <p>Ensure that suitably low quantitation limit, and MDL can achieve \leq pg/L sensitivity for each PCB congener</p> <p>Gain regulator, environmental consultant, and contract lab acceptance</p> <p>Cost for PE sampler approach less than or comparable to traditional sampling and analysis</p>	<ul style="list-style-type: none"> • for congeners with >30% approach to equilibrium during sampler deployment, data precisions better than $\pm 50\%$. • comparisons to direct porewater extractions shows PE same within error of each (i.e., $2 \times \pm 20\%$) • MDLs depend on PE sampler size and GC/MS instrumentation, but are near 1 pg/L for individual PCB congeners. • environmental regulators (EPA Regions 2 and 9) and companies besides ICF International (CH2M-Hill, Louis Berger, HDR) have used PE sampling and/or PE data to characterize contaminated sites • current contract lab charges for congener-specific PCB analysis of PE samples are the same as for sediment sample • costs of field sampling and analysis comparable to traditional approaches relying on sediment sampling

Performance Objective 1: *Demonstrate PE Passive Sampling Accurately Provides Measures of Porewater Concentrations.*

Since porewater concentrations can be related to contaminant mobilities and bioavailabilities, our first goal was to show that the PE passive sampling yielded accurate porewater concentration results.

This required us to collect data using accepted methods for measuring porewater concentrations using isolated porewater samples, and contrast these results with corresponding data found using the PE passive samplers in the same sediments. To insure the data came from the same sediments, this objective was pursued using laboratory testing (i.e., "*ex situ*") of PE passive sampling in homogenized site sediments.

The data showed that PE-inferred porewater concentrations for individual PCB congeners were statistically indistinguishable from results obtained by extracting porewater samples from the same sediment.

Performance Objective 2: *Demonstrate PE Passive Sampling Is Effective for Site Mapping.*

In order to characterize the risks associated with contaminated sediments at sites of interest, as well as to design suitable means for clean up, we must quantitatively characterize the distribution of the contaminants of concern.

To accomplish this objective, we used PE passive samplers in both *ex situ* samples (i.e., sediments collected from the demonstration site and removed to the laboratory) and *in situ* deployments (i.e., PE samplers inserted in sediment beds in the field at our demonstration site). After the samplers were removed from the sediments, their PCB contents were measured and used to deduce the porewater concentrations of individual PCB congeners for each sediment site (and often as a function of depth into the bed). For comparison, traditional measures of sediment concentrations and isolated porewater concentrations were also measured for each site. Finally, the porewater concentration (from both porewater extractions and PE samplers) and the sediment concentration data were mapped using a data interpolation program (Surfer[®]) to delineate and contrast the contamination from each data set's the horizontal and vertical extent of PCBs.

This objective also met with success as porewater concentration maps were readily generated using the PE data. Using sediments tested with PE *ex situ*, the overall extent of contamination using extracted pore waters and PE-inferred porewater concentrations were quite similar. This differed substantially from the results seen using the sediment concentrations.

Interestingly, sediments sites tested *in situ* did not show porewater concentrations that were the same as found in pore water recovered from sediments returned to the laboratory. While this may appear to indicate a failure to meet this objective, this result actually alerted us to the fact that nearby pumping of groundwater was causing lake water to continuously infiltrate into the demonstration site's sediment bed and thereby reduce pore water concentrations *in situ*.

Performance Objective 3: *Demonstrate PE Passive Sampling Is Suited to Long Term Monitoring (LTM) After Site Remediation.*

Since remediated sites must commonly be monitored to insure that biological exposures remain at acceptable levels after the site has been cleaned up, we need dependable and reproducible methods to measure contaminant concentrations in surface waters and pore waters. Moreover, it is important to be able to evaluate the effectiveness of the cleanup approach for reducing contaminant fluxes out of the bed to acceptable levels.

To evaluate the effectiveness of PE samplers for assessing natural recovery/burial and dredging/capping at our demonstration site, we used PE samplers annually after the demonstration site was dredged and capped to quantify PCBs in pore waters and bottom waters at the site. The data showed that bottom water and pore water concentrations were not changing significantly with time. Also PCB porewater profiles through the sand caps did not indicate a continuing flux of PCBs through the cap into the lake.

Performance Objective 4: *Demonstrate PE Passive Sampling Commercially Viable Based on QA/QC Metrics, Ease of Use, and Costs*

In order for this passive sampling technology to be adopted, the equipment must be readily obtained, practically deployable, and the costs must be less than, or at least comparable to, existing approaches.

To demonstrate these considerations, the project's participants at ICF International performed both traditional sediment sampling and deployment of the PE passive samplers at our study site to contrast the levels of effort required by each method. Likewise, colleagues at Pace Analytical participated in PE analyses so as to judge its level of difficulty from the contract laboratory point of view.

In both cases, the ease of PE sampler deployment/recovery and later chemical analysis were found to be comparable to current practices using sediment sampling. Additionally, we developed standard operating procedures (SOPs) that can be adopted by consultants and contract laboratories for preparation and use of PE (Appendix B).

Moreover, in order for PE passive sampling to be commercially viable, one must demonstrate that the data gained will fulfill the requisite needs associated with assessing a contaminated sediment site. Such needs include providing data of sufficient quality to be used in contaminant exposure assessment models and suited to guiding remedial designs.

To this end, we demonstrated the construction and performance of a simple, sturdy, cost-effective PE passive sampler, and its method for deployment and recovery, which is flexible enough to apply to a range of sediment bed materials. We also developed data demonstrating the substantially improved accuracy of using the PE passive samplers (relative to using sediment concentrations), as well as generation of regulator-acceptable QA/QC data. In particular, we showed that the PE passive sampler sensitivity for individual PCB congeners is at a level that corresponds to about 1 pg/L, a sensitivity that is difficult to achieve using the common sampling and analysis procedures.

4.0 SITE DESCRIPTION

4.1 SITE LOCATION AND HISTORY

The South Pond of Lake Cochituate (specifically Pegan Cove) in Natick, Massachusetts (approximately 17 miles west-southwest of Boston) was the primary site for the PE passive sampling technology demonstration (Fig. 5). The U.S. Army Natick Soldier Systems Center (NSSC) is an active DoD research and testing facility that is located on the shoreline of Lake Cochituate. NSSC has been a permanent Army installation since 1954, and its mission includes research and development activities in food engineering, food science, clothing, equipment, and materials engineering. NSSC was added to the National Priorities List (NPL) under CERCLA in May 1994 to evaluate and implement responses to past releases of hazardous substances.

Most surface drainage at the NSSC facility is controlled by the storm sewer system, which discharges to Lake Cochituate at a number of outfalls, including a main outfall discharging to Pegan Cove in South Pond. For 60 years, runoff from parking lots, equipment storage areas, bulk chemical storage areas, areas with high vehicle traffic, and unpaved areas has contributed to the presence of PAHs, PCBs, pesticides, and metals in the Lake Cochituate sediment adjacent to NSSC. In particular, one confirmed PCB-containing transformer release occurred at the NSSC facility during the mid-1980s, and is believed to be largely responsible for the elevated PCB concentrations in sediment.

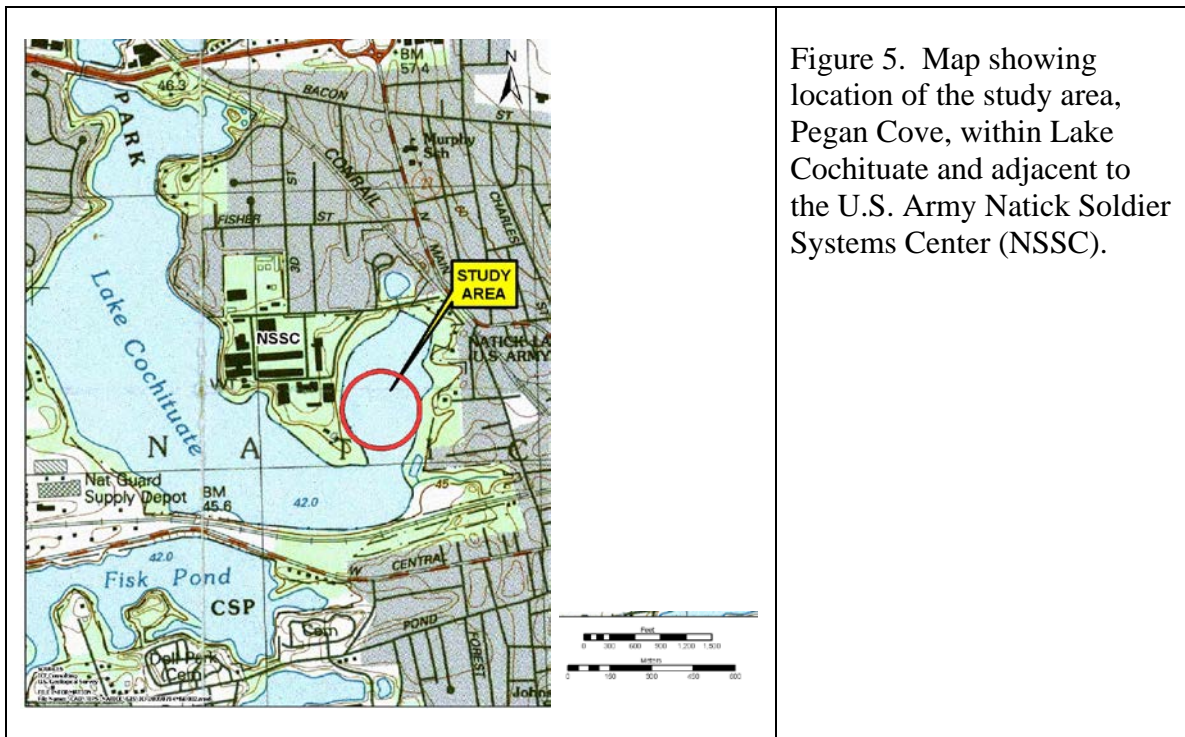

Figure 5. Map showing location of the study area, Pegan Cove, within Lake Cochituate and adjacent to the U.S. Army Natick Soldier Systems Center (NSSC).

4.2 SITE GEOLOGY/HYDROGEOLOGY

Lake Cochituate is composed of five interconnected ponds (Fisk, South, Carling, Middle, and North) separated by several major roadways. The lake lies in the Sudbury River Basin and is a part of the Cochituate State Park. The flow of the ponds is from south to north. South Pond of Lake Cochituate is located in an urban-suburban setting in Natick, Massachusetts. The NSSC property is located on a peninsula in the South Pond.

The South Pond of Lake Cochituate is 233 acres in area, is approximately 69 feet at its deepest, and has a mean depth of 19.8 feet (USGS, 2001). The water depth in Pegan Cove of South Pond, where the PE study was implemented, has a maximum depth of about 10 feet.

The texture of the sediment in Pegan Cove is generally silty clay. Nearshore sediment tends to consist of a larger percentage of sand, due to the winnowing of the finer-grained sediment from shallow water wave action. In deeper water (e.g., 5 to 10 feet), sediment tends to consist of predominantly of silts and clay, with substantial peaty debris. The organic matter content in sediment in Pegan Cove is high. Surface sediment samples collected within Pegan Cove in 2007 (ICF, 2009) had fractions of organic carbon (f_{oc}) ranging from 1 to 38%. The water content in Pegan Cove sediments is also high, and porosities are typically above 90%.

It is notable that, during this demonstration project, we found that a set of water supply wells (Natick Springvale wellfield) is pumping year round from a position about 1200 m from Pegan Cove. The pumping occurs year round, but was maximal during the summers of 2010 and 2011 (see Appendix C). The calculated zone of influence suggests that lake water is constantly being drawn into the sediments of the Cove (Figure 6). Temperature profiles taken by us into the sediment bed support this as they indicate downward porewater flows of centimeters per day. This situation may cause sorptive disequilibrium of PCBs in the porewater and the sediment.

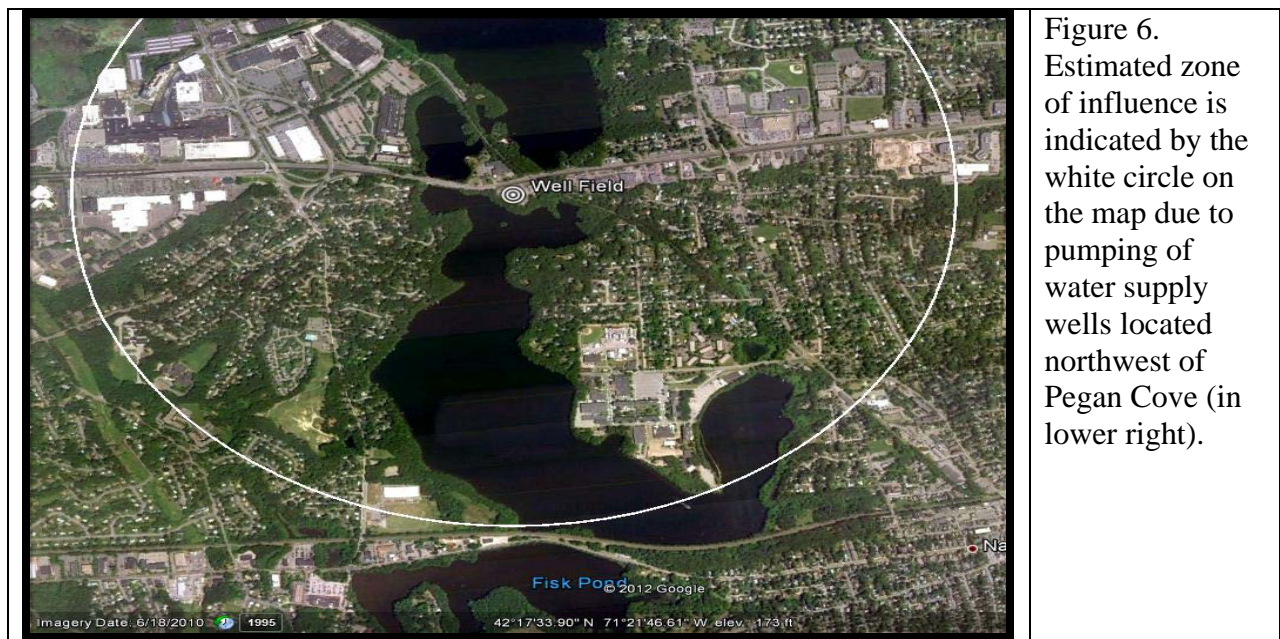

4.3 CONTAMINANT DISTRIBUTION

Since the mid-1990s, hundreds of sediment samples have been collected from Lake Cochituate in association with environmental investigations conducted at NSSC (Figure 7 for total PCB concentrations in sediment from the most recent sampling event conducted in the fall of 2007). Total PCB concentrations within the Pegan Cove area ranged from 0.15 to 4.1 mg/kg (average of 1.7 mg/kg). The 2007 data indicated that elevated total PCB concentrations extend across much of the Pegan Cove area, and are greatest along the NSSC shoreline, particularly at, and to the south of, the main outfall.

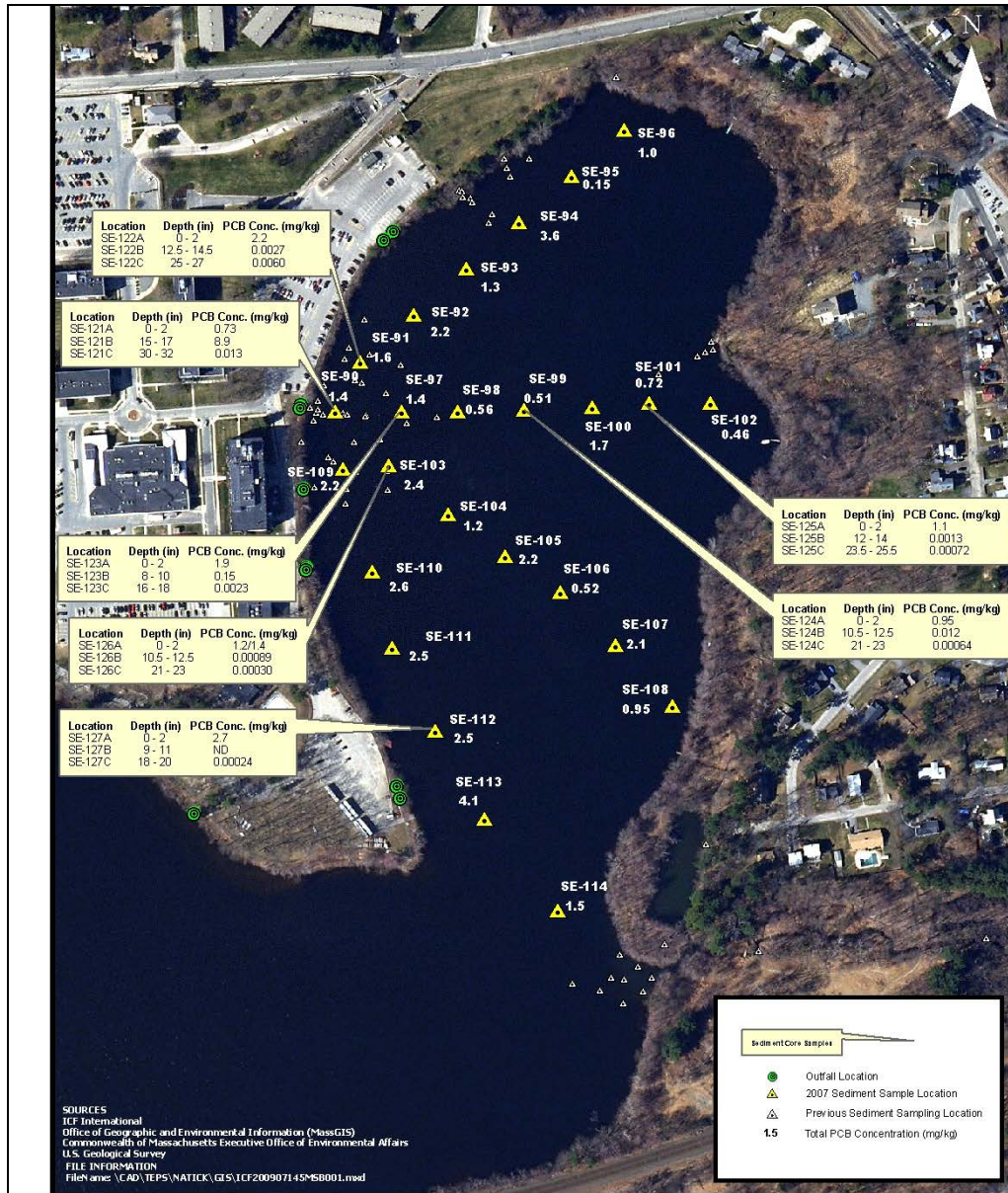
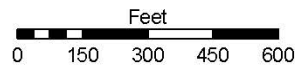

Figure 7. Distribution of PCBs (mg/kg) in the sediments of Pegan Cove (measured in 2007).

Figure 4
Total PCB Sediment Concentrations
Pegan Cove, Lake Cochituate



5.0 TEST DESIGN

5.1 CONCEPTUAL EXPERIMENTAL DESIGN

We demonstrated the performance and cost effectiveness of our PE passive sampler at the NSSC site where PCB contamination of the sediments has been a concern. In the initial phase of the project, sediment samples were collected from the lake for laboratory or *ex situ* testing (Table 2). Subsequently, several PE deployments were made *in situ* within the sediments of Pegan Cove, where elevated PCB concentrations have been detected in the sediments and biota, including game fish, during prior CERCLA investigations.

At each stage, we used the data to ascertain the effectiveness of the PE approach, especially as it can be contrasted to the "traditional" means or site assessment. This was done considering both performance and cost metrics. The following table summarizes the field campaigns throughout this ESTCP project.

sample round	goal(s)	sampling or deployment date	retrieval date	number of days deployed	sample numbers	comments samplers lost
round 1	recover sediment for lab testing PE passive samplers	not applicable	Nov 2009	not applicable	0 – 10	sediments retrieved
round 2	begin PCB site mapping, LTM	Dec 3, 2010	Apr 7, 2011	125 days	11 – 20	sediments retrieved
round 3	continue PCB site mapping, examine field replication	May 27, 2011	June 28, 2011	32 days	21-40	sediments retrieved
round 4	continue PCB site mapping	Oct 17, 2011	Nov 16, 2011	31 days	41-60	44, 49, 55
round 5	LTM	Nov 17, 2011	May 3, 2012	168 days	61-70	61, 63-68, 70
round 6	test lake water infiltration, LTM, cap testing	Oct 17, 2012	Dec 5, 2012	47 days	71-79	73, 77(site 50 repeat)

5.2 BASELINE CHARACTERIZATION

Baseline site characterization had previously been performed as part of ICF International's long term involvement at the demonstration site (ICF International, 2009). As a result, the following information is readily available: (1) lake bathymetry, (2) lake sediment characterization, (3) PCB distributions in the lake sediment bed as of 2009, and (4) body burdens of PCBs in lake biota, including shellfish and finfish.

5.3 LABORATORY STUDY RESULTS

The effectiveness of the PE passive sampling technology depends on its ability to provide chemical concentration data suited to (a) evaluating HOC mobility and bioavailability and (b) assessing vertical and horizontal distributions, and (c) following temporal HOC distribution changes during long term monitoring (LTM). The key data needed to achieve these objectives involves measures of the contaminants' pore water concentrations in the sediments.

Hence, our initial efforts involved demonstrating that the PE sampling technology yields porewater concentration data that are consistent with "traditional" measures of such porewater concentrations. Traditional measures require isolating porewater from sediments, removing or accounting for any colloids in the water, extracting the HOCs of interest, and quantifying the dissolved HOCs via methods such as GC/MS. Such traditional means are quite time-consuming, and they generally suffer from insufficient sensitivities needed to assess low-solubility HOCs like PCBs.

We collected sediments from 20 stations distributed around our demonstration site during our first two sampling rounds (Figure 8, lat/long in Appendix D). Briefly, the sediments were returned to the laboratory where they were thoroughly homogenized (Follett, 2011). Subsamples were taken for porosities (water loss on drying used to calculate water-filled volume fractions) and organic carbon contents (f_{oc} , reported as weight fractions, Figures 8). The lake sediments were very porous (~90%) and they exhibited high organic carbon content (average 14% organic carbon by weight). Analyses of black carbon (BC) using the method of Gustafsson et al. (1997) indicated this component contributed about 8% of the total organic carbon (Appendix E).

Batches of the sediments were centrifuged to isolate pore water, and alum was used to remove colloids (Hawthorne et al., 2005). Recovery standards were added, and then the pore water was extracted three times with dichloromethane (DCM). After the combined solvent volume was reduced, injection standards were added, and 1 μ L aliquots were analyzed by GC/MS. Porewater concentrations of individual PCB congeners were calculated correcting for standard recoveries.

In parallel, aliquots of the sediment samples were placed in glass jars for *ex situ* PE passive sampling (i.e., in the lab, rather than in the field) to insure the PE sampled the same pore water as that which was isolated by centrifugation. (NOTE: this approach avoided problems associated with *in situ* PE use in which the pore water may be flushed by groundwater infiltration induced by water well pumping; see Appendix C showing seasonal pumping variations for 2010 and 2011.) PE preparation procedures followed those described in Gschwend et al., 2012a). Pieces of PE were solvent cleaned and then loaded with performance reference compounds (PRCs). Subsequently, the PE pieces were inserted into the quiescent mud (i.e., passive sampling) to allow uptake of the target PCBs from the samples. For two of the sites (1 and 8), replicate sampling was done ($N = 11$ or 13) to allow determination of the passive sampling method's reproducibility. After a month, passive sampling was terminated, the PE strips were wiped clean. Two of the PE strips from each treatment were sent to Pace Analytical for analyses. At MIT, surrogate standards were added to the remaining replicates, DCM was used to extract the PE, and the extracts were analyzed by GC/MS generally following procedures described in Gschwend et al. (2012c). The observed build-ups of target PCBs were corrected for not reaching

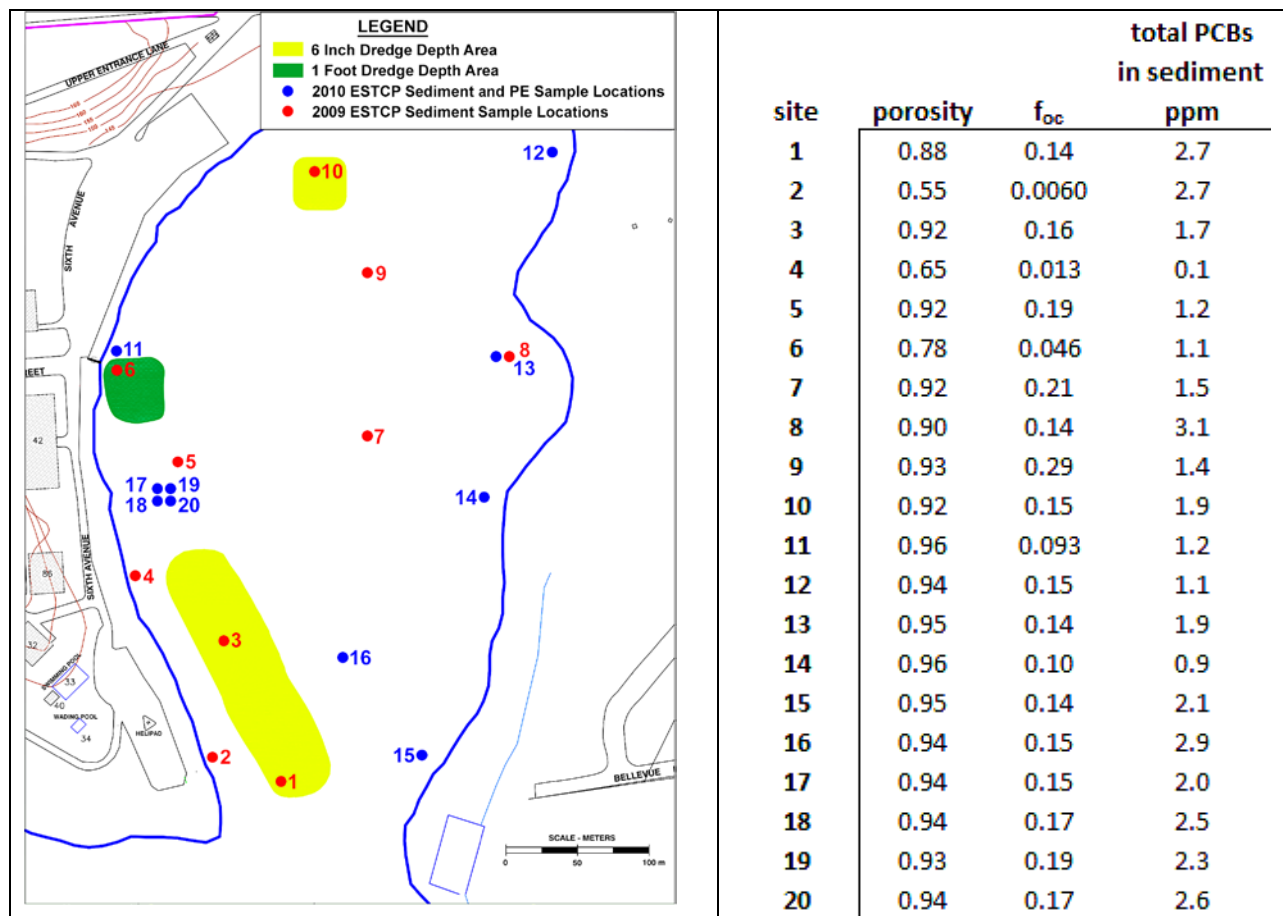

Figure 8. (left) Map of 20 stations distributed in Pegan Cove, Lake Cochituate. Note that 2009 samples (red points and nos. 1-10) were taken before dredging, while 2010 samples (blue points and nos. 11-20) were taken after dredging which was done in areas indicated by yellow and green shading. (right) Sediment porosities (volume fractions), organic carbon contents (weight fractions), and Σ PCBs (mg/kg dw) are shown for each station; note stations 17, 18, 19, and 20 were located on the corners of square that was 10 m on a side. Stations 2 and 4 were located at near-shore sandy locations and had distinctly lower porosities and organic carbon contents (f_{oc}).

equilibrium using the measured losses of the PRCs (Fernandez et al., 2009b). Finally, porewater concentrations were deduced by dividing the PE concentrations by each congener's PE-water partition coefficient, K_{PEw} .

Lastly, solvent extractions of the sediments themselves with GC/MS analyses were used to determine the PCB concentrations in the sediments. Subsequently, the Equilibrium Partitioning (EqP) approach (DiToro et al., 1991) was applied to estimate porewater concentrations. In this method, porewater concentrations are calculated using sediment concentrations and an estimated value of the sorption coefficient, K_d , for each HOC ($C_{porewater} = C_{sediment}/K_d$). Sorption coefficients were estimated using the sediment's organic carbon content, f_{oc} , and the HOC's organic carbon-normalized sorption coefficient, K_{oc} , where values of this parameter were taken from Hansen et al. (1999).

Table 3. Testing method reproducibility using *ex situ* replicate testing of PCB porewater concentrations (ng/L) found using PE passive samplers in homogenized field sediments AFTER applying corrections using PRCs.

	N	mean	stdev	rel err		N	mean	stdev	rel err
site 1				(%)	site 8				(%)
#52	11	0.45	0.14	30	#52	13	0.84	0.37	44
#101	11	0.39	0.23	58	#101	11	0.31	0.15	50
#153	11	0.71	0.46	64	#153	11	0.27	0.24	89
#180	11	0.29	0.21	71	#180	11	0.12	0.12	102

Together, the resultant data allowed us to demonstrate how well PE- or sediment-based measures compare with direct measures of pore water concentration for individual PCB congeners.

This *ex situ* passive sampling exercise demonstrated several important outcomes. First, the measurement precisions seen for >10 replicate PE samplings of sediments from 2 stations, each at 4 PCB spike levels, for four individual congeners was $22 \pm 6\%$ relative standard deviation (RSD). Also, comparison of our PCB measurements with those made by Pace Analytical showed good correspondence, suggesting the accuracy of the MIT lab's methods.

But in order to translate PE data into porewater concentrations, one must use the PRCs to adjust the accumulated PCB concentrations in the PE up to what they would be at equilibrium with the sediment. This involves propagating the errors of measuring both the target and PRC compounds. We used four ^{13}C -labelled PCB congeners as PRCs (^{13}C -labelled congener nos. 47, 111, 153, and 178). The error associated with knowing their losses causes one to know the porewater concentrations of the "small" target PCB congeners (e.g., #52, a tetrachlorobiphenyl, and #101, a pentachlorobiphenyl) to within about 50% RSD (Table 3). However, larger congeners (e.g., congeners #153 and 180) whose approach to equilibrium is less certain, based on small fractions of PRCs lost, grow to about a factor of 2 uncertainty. This made estimates for larger PCBs (hexa- and hepta-chloro) much less certain. Consequently, at this stage we realized that future work required more PRCs (see below).

Meanwhile, we evaluated the accuracy of the *ex situ* PE passive sampling by comparing individual congener concentrations measured in extracted pore waters with values deduced using the PE samplers for 18 sites from Pegan Cove (Figure 9). In general, we found that the ratios of porewater concentrations of individual PCBs (#52, #101, and #153) measured using the PE samplers divided by the porewater concentrations found by isolating and extracting the pore waters were statistically indistinguishable from 1 (Figure 9). (Note: the data for congener #180 is not shown as the error on its concentration was so large as a result of insignificant loss of PRC #178). This correspondence between PE-inferred results and those from direct porewater extractions was true for sediments with very low organic contents (e.g., sites 2, 4, and 6) and ones with high f_{oc} , as well as for sediments with PCB concentrations ranging from about 1 ppm to almost 3 ppm.

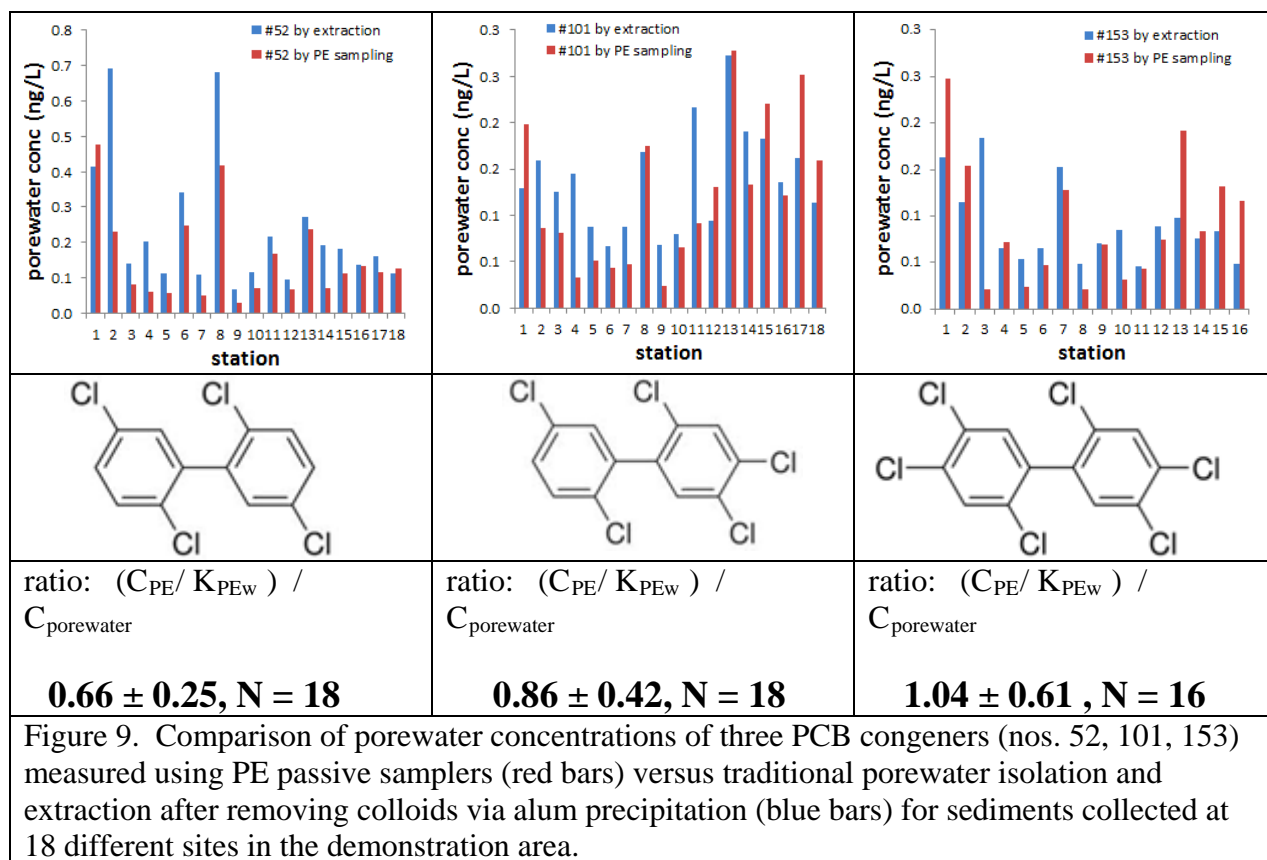

Figure 9. Comparison of porewater concentrations of three PCB congeners (nos. 52, 101, 153) measured using PE passive samplers (red bars) versus traditional porewater isolation and extraction after removing colloids via alum precipitation (blue bars) for sediments collected at 18 different sites in the demonstration area.

We also compared the direct porewater extraction results with what one finds using the current practice of using sediment concentrations, normalized by an estimate of $K_d = f_{oc} K_{oc}$ (Figure 10). The PE-inferred values scattered around the 1-to-1 line, and their magnitudes were not statistically different from the concentrations found by porewater extractions:

$$C_{PE}/K_{pe-water} = 0.53(\pm 0.8) * C_{porewater} + 0.048 (\pm 0.014)$$

In contrast, estimates based on sediment concentrations were statistically higher than the extracted porewater results, averaging about 5x greater:

$$C_{sediment}/f_{oc}K_{oc} = 4.6(\pm 1.7) C_{porewater} + 0.35 (\pm 0.29)$$

Clearly, the PE-based approach is far more accurate than what is done in the current practice.

5.4 FIELD TESTING

As indicated in Table 2, sampling rounds 2 through 6 all involved deployments of PE samplers in the field (referred to herein as *in situ* measures). Initial efforts were intended to gain data for contamination mapping (rounds 2, 3, and 4). In particular, PE samplers used in round 2 (stations 11 through 20) were sectioned in 5 cm lengths and each layer was analyzed for PCBs in order to evaluate vertical profiles of dissolved PCBs into the sediment bed. Four samplers located 10 m apart at the corners of a square (stations 17, 18, 19, and 20) were also sectioned and analyzed in

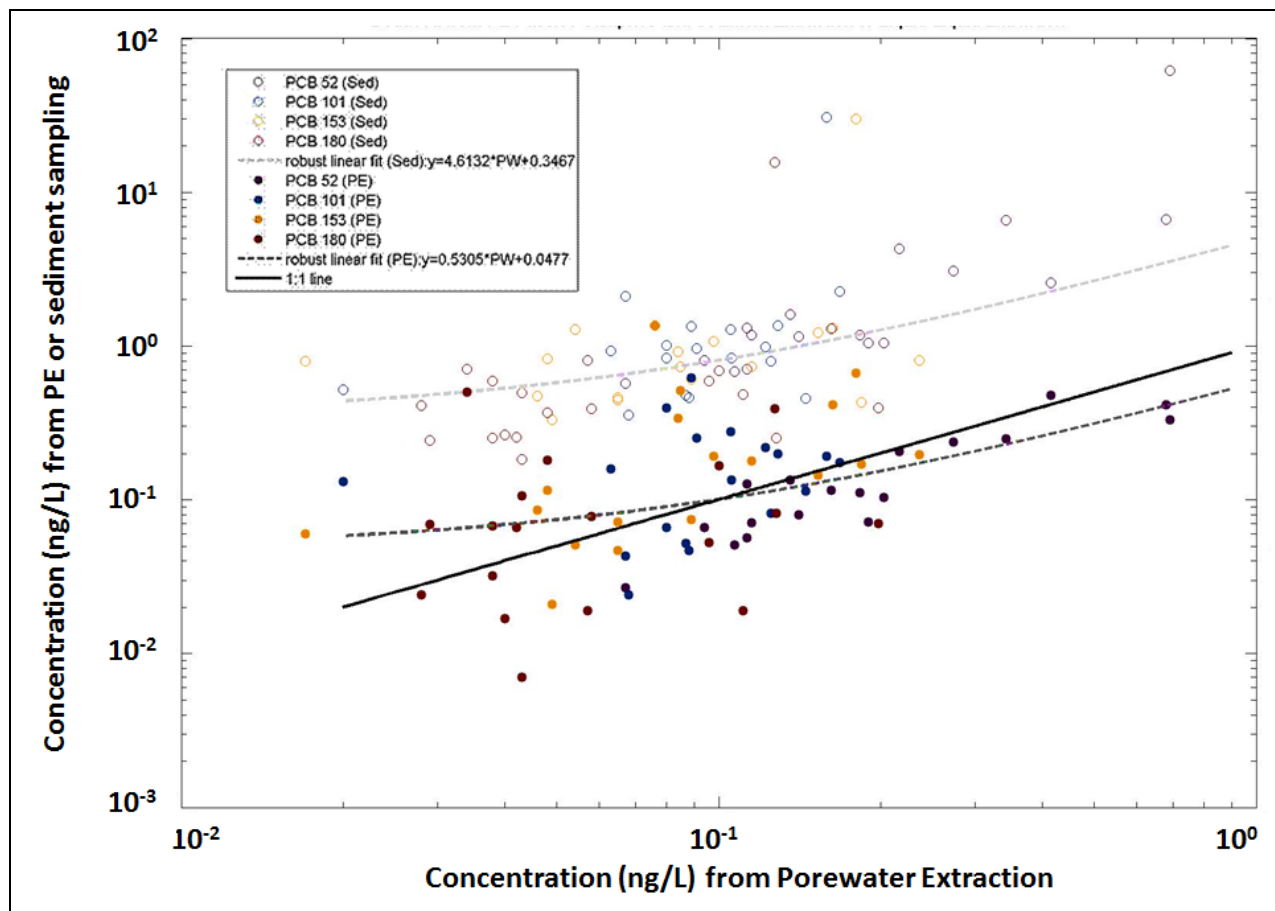

Figure 10. Comparison of individual PCB congener concentrations found by direct extraction of pore water samples from 18 stations with values deduced using passive PE sampling (filled circles: $(C_{PE}/K_{pe-water}) = (0.53 \pm 0.8) C_{porewater} + 0.048 \pm 0.014$) and using sediment concentrations (open circles: $(C_{sediment}/f_{oc}K_{oc}) = (4.6 \pm 1.7) C_{porewater} + 0.35 \pm 0.29$).

this way to reveal something about the horizontal heterogeneity of the porewater PCB concentrations at the ~10 m scale.

Superimposed on this effort was the deployment of samplers to annually obtain long term monitoring results (rounds 2, 5, and 6). Finally, field sampling was also performed for the special purposes of (a) assessing the integrity of the sand caps and (b) gaining data indicative of the impact of groundwater pumping.

5.5 SAMPLING METHODS

PE Sampling and Analysis.

The procedures for preparing PE passive samplers, for deploying them, and finally for analyzing the polyethylene and translating those results into corresponding HOC water concentration data

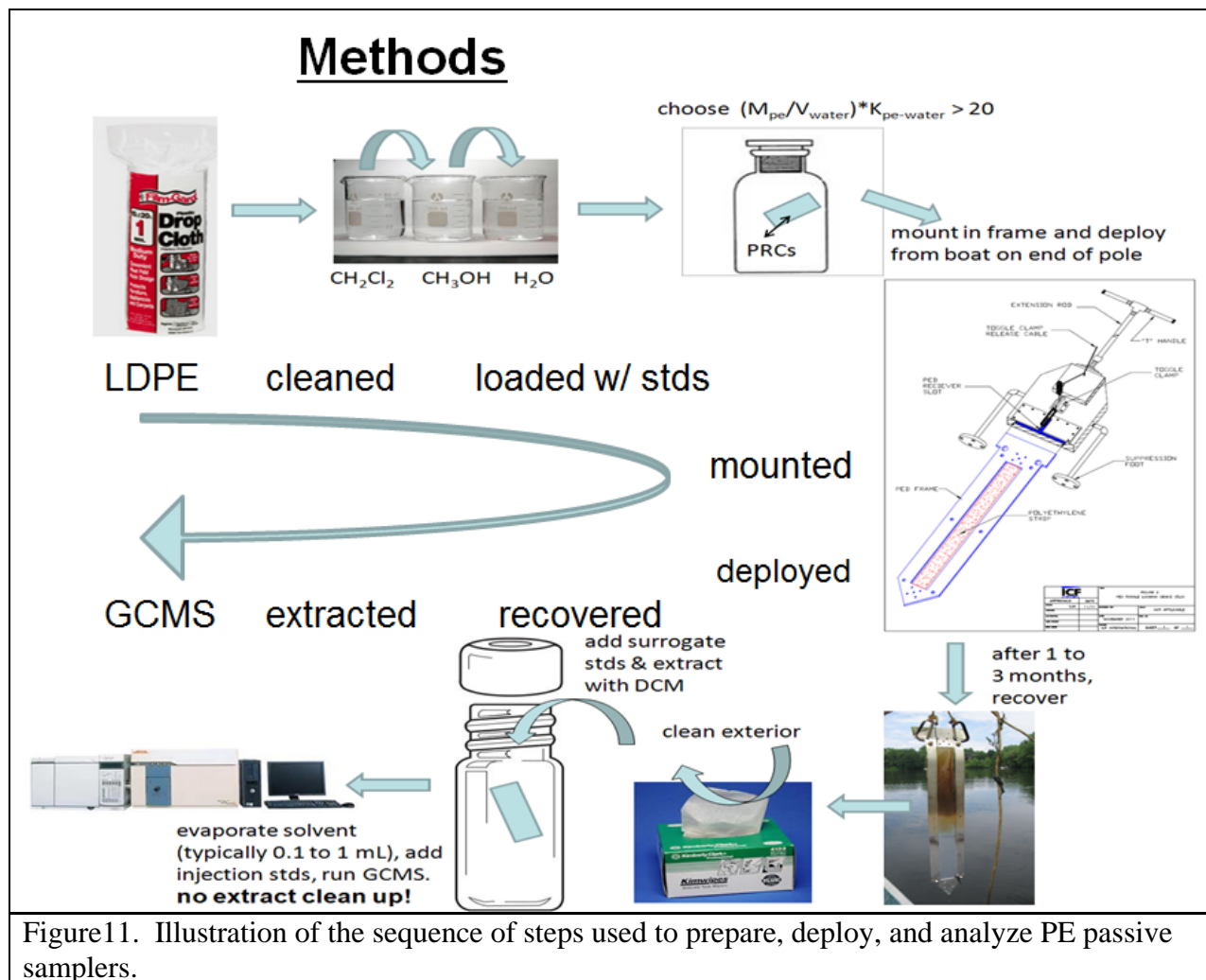

Figure 11. Illustration of the sequence of steps used to prepare, deploy, and analyze PE passive samplers.

are all thoroughly described in a set of three SOPs posted on-line at the ESTCP web site (Gschwend et al., 2012a, 2012b, and 2012c.) The general procedure is illustrated in Figure 11. Briefly, polyethylene sheet is purchased from a hardware store. It is cleaned using organic solvents, and then loaded with appropriate PRCs as suitable concentrations for the contaminated site of interest. To deploy the PE sheet, it is mounted in an aluminum sheet metal frame and the investigator inserts the assembled sampler into the sediment of interest, leaving some of the PE exposed in the site's bottom water. After suitable deployment time (e.g., a month depending on the target contaminants), the sampler is retrieved, the PE is wiped clean of adhering sediment or biofilm growth, and the contaminants are extracted into organic solvents. The extracts are analyzed by suitable methods (e.g., GC/MS). Finally, the measured PE concentration data is extrapolated to equilibrium values using the measured PRCs' data in the "Performance Reference Compound Calculator" (available at <http://www.serdp.org/Program-Areas/Environmental-Restoration/Contaminated-Sediments/ER-200915>). This result is translated to a corresponding water concentration using each compound's polyethylene-water partition coefficient, K_{PEw} .

Pore Water and Sediment Sampling.

To assess the accuracy of the *in situ* PE-based results, we also collected corresponding samples for pore water and sediment analyses (Table 4). We used a ponar dredge to collect surface (0"-6") sediment samples from loci having a range of PCB contamination levels at the site. These samples were homogenized at the MIT lab, and then a split sample was used to obtain pore water. Pore waters were acquired by placing sediments in glass centrifuge tubes and then centrifuging for 30 to 60 min at 900g to separate the pore waters from the sediment solids. Porewater colloids were removed using alum.

PE, porewater, and sediment were analyzed via previously reported methods (Tble 5). Briefly, dichloromethane extracts were analyzed by GC/MS with the chromatography performed as described in EPA Method 8082a. Splits of these samples were also sent to Pace Analytical for PCB congener-specific analyses to confirm data accuracy and provide inputs for cost estimates via traditional methods. We measured organic carbon and black carbon in dried and ground sediment sub-samples using a Vario EL III CHN elemental analyzer (Gustafsson et al. 1997).

Table 4. Total number and types of samples collected.					
Objective	Location	Matrix	Number of Samples	Analyte Measured at MIT	Duplicate Analyses at Contract Lab
1. Demonstrate PE Passive Sampling Accurately Provides Measures of Porewater Concentrations	sediment surface grabs, distributed locations with range of PCB concentrations from Pegan Cove, Lake Cochituate	PE (lab incubated)	25	25x PCBs	16 x PCBs
		pore water	25	25x PCBs,	2 x PCBs
		sediment grabs	25	25x PCBs, 7x f _{oc} , f _{BC}	2 x PCBs
2. Demonstrate PE Passive Sampling Is Effective for Site Mapping.	distributed locations exhibiting range of PCBs concentrations from Pegan Cove, Lake Cochituate	PE (field incubated)	60 strips	264x PCBs	8 x PCBs
		pore water	12	17 x PCBs	
		sediment cores	20	12x PCBs (7 x 3 depths)	
3. Demonstrate PE Passive Sampling Is Suited to Long Term Monitoring (LTM) After Site Remediation	allow transect from hot spot to relatively clean location from Cove out to larger lake	PE (field incubated)	annually (i.e., in each of 3 years) at multiple locations and reflecting multiple depths at each location	74x PCBs	
4. Demonstrate PE Passive Sampling Commercially Viable Based on QA/QC Metrics, Ease of Use, and Costs	distributed locations exhibiting range of PCBs concentrations from Pegan Cove, Lake Cochituate	PE	2 sediment grab samples, each spiked at 3 levels: incubated with PE, extracted for pore water, and sediment sampled	80x PCBs (10 PE replicates of native and 3 PCB spike levels) 8 PCBs	16 (2x 4 PCB spike levels in sediments from 2 stations)

Matrix	Analyte	Method	Container	Preservative	Holding Time
PE	PCBs	SOP for PE analysis (see Gschwend et al. 2012c)	glass vial	cold	30 days to extract
pore water	PCBs	EPA 8082a except MS detection instead of ECD	glass	cold	7 days to extract
sediment	PCBs	EPA 8082a except MS detection instead of ECD	glass	cold	1 year
sediment	f_{oc} , f_{BC}	Gustafsson et al., 1997	glass	cold	1 year

6.0 PERFORMANCE ASSESSMENT

6.1 Performance Objective: Demonstrate PE Passive Sampling Accurately Provides Measures of Porewater Concentrations

In light of the need to assess the mobilities and bioavailabilities of HOCs like PCBs, our initial objective was to show that porewater concentrations found using PE passive sampling were accurate. Such accuracy was evaluated by comparing the PE results to what is found by isolating porewater from the same sediments, removing colloidal phases, and the analyzing the water for its dissolved HOC contents.

In light of the initial laboratory testing of PE passive sampling performance, two key changes were made in the method. First, because the larger PRCs were insufficiently lost from the samplers during their deployments, we changed the PE preparation method so as to use more than four PRCs (Table 6). Moreover, the PRC set includes two PRCs with a greater likelihood of significant losses (i.e., congeners 28 and 54). Secondly, we developed a graphic user interface called "PRC Correction Calculator" (Figure 12), based on the mass transfer model of Fernandez et al. (2009b), that allows the investigator to fit the PRC loss data that is deemed analytically

Performance Reference Compounds			
		$\log K_{ow}$	$\log K_{pew}$
^{13}C PCB 28	2,4,4'-Trichlorobiphenyl	5.67	5.38
^{13}C PCB 54	2,2',6,6'-Tetrachlorobiphenyl	5.21	4.92
^{13}C PCB 47	2,2',4,4'-Tetrachlorobiphenyl	5.85	5.56
^{13}C PCB 97	2,2',3,4',5'-Pentachlorobiphenyl	6.29	6.00
^{13}C PCB 111	2,3,3',5,5'-Pentachlorobiphenyl	6.76	6.47
^{13}C PCB 153	2,2',4,4',5,5'-Hexachlorobiphenyl	6.92	6.63
^{13}C PCB 178	2,2',3,3',5,5',6-Heptachlorobiphenyl	7.14	6.85

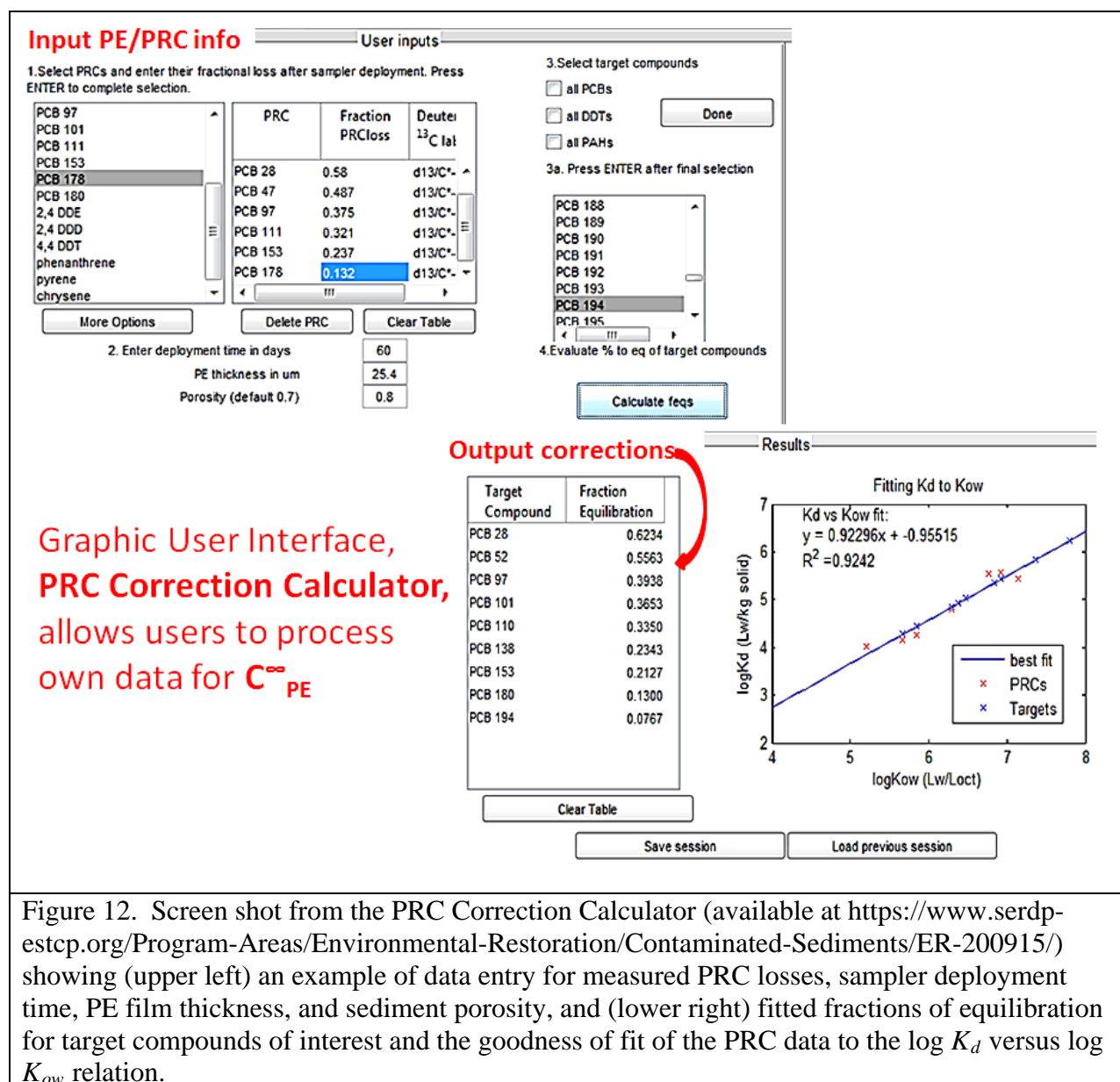

dependable (e.g., using only those PRCs showing >10% loss and >10% remaining) and then applied the fit to other HOCs with different mass transfer properties (e.g., K_{PEw} , D_w , D_{PE}). This PRC Correction Calculator is available at <https://www.serdp-estcp.org/Program-Areas/Environmental-Restoration/Contaminated-Sediments/ER-200915/>. Testing of these changes shows very good results (Figure 13). We found that they agreed on average to within 15% (N=10), and were at worst within a factor of 1.5 of each other. To sum, we find that PRC loss data, processed with the PRC-Correction Calculator, accurately evaluated fractional gains of target compounds.

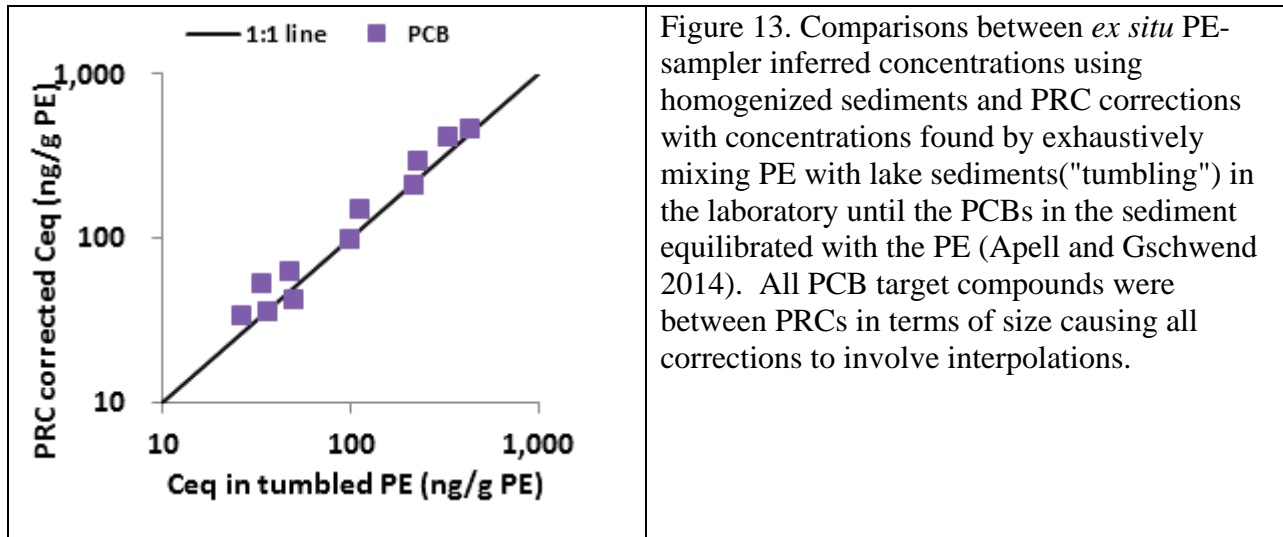

Next, initial *in situ* PE passive sampling consistently showed lower porewater concentrations than corresponding *ex situ* measurements made with sediments that were returned to the laboratory (Figure 14). This suggested that lake sediments and their pore waters were not at sorptive equilibrium in the field. We found various lines of evidence supporting this, including (a) calculations of the zone of influence of nearby water supply wells imply lake water infiltration in Pegan Cove, (b) temperature profiles in the sediments of the Cove indicate inflows from the lake at centimeters per day, (c) ratios of PCB congeners in the surface sediment show that less hydrophobic PCBs are depleted relative to more hydrophobic ones as a function of time.

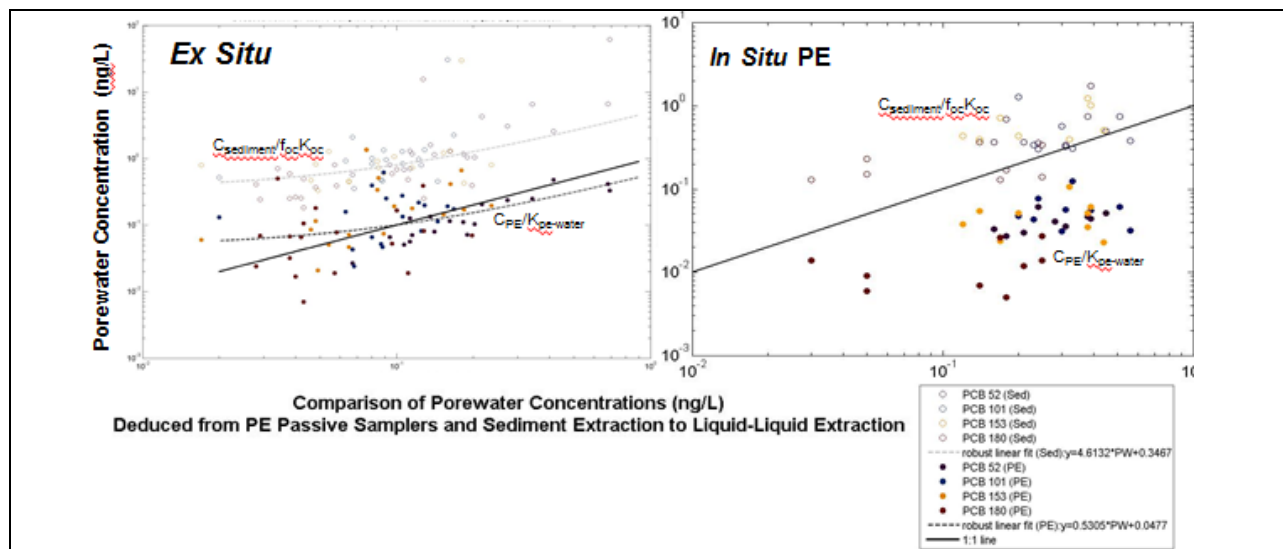

Consequently, we pursued this performance objective using *ex situ* testing of additional sediments collected in field sampling round 3 (Figure 15), to see whether using more PRCs would enable even greater correspondence with porewater extractions for a wider range of congeners (Apell and Gschwend, 2014). As before, sediments came from all over Pegan Cove and had total PCBs ranging from 1.3 to 3.2 ppm.

In this test, all congeners that could be detected using direct porewater extractions were found to be well-predicted using the PE passive sampling (Figure 16). Considering a tetrachlorobiphenyl (#52), a pentachlorobiphenyl (#101), a hexachlorobiphenyl (#153), and a heptachlorobiphenyl (#180), deviations were always within a factor of 1.7. Remembering that analysis of such low levels in porewater also carry significant uncertainty, this correspondence is very good.

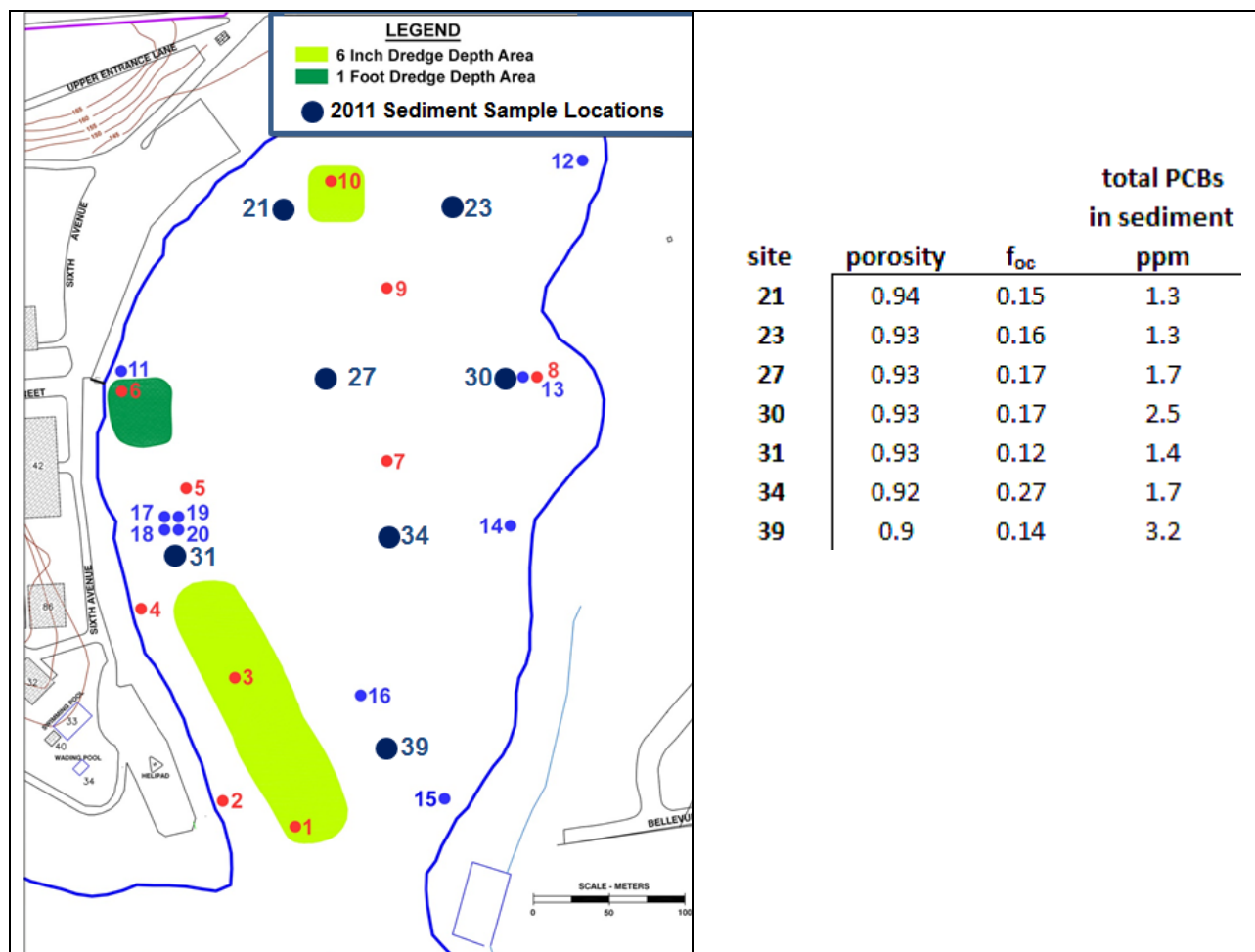

Figure 15. (left) Map of 7 additional stations (black circles with nos. between 21 and 39) in Pegan Cove, Lake Cochituate, tested with *in situ* PE samplers in May-June 2011. Porosities (volume fractions), organic carbon contents (weight fractions), and Σ PCBs (in mg/kg dry weight) are also shown.

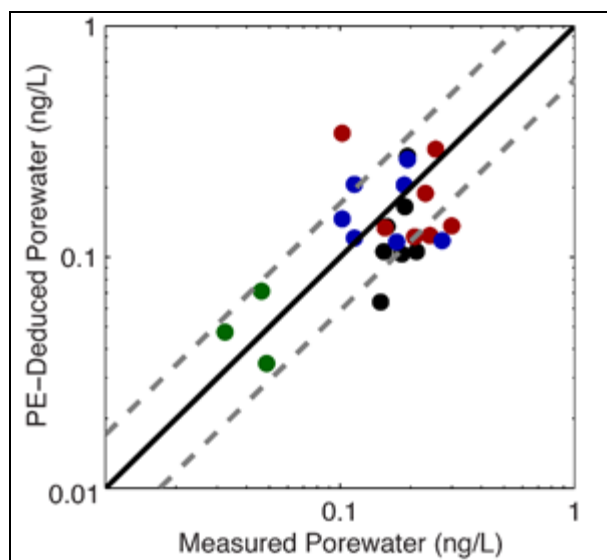

Figure 16. Porewater concentrations of four PCB congeners: 52 (black), 101 (red), 153 (blue), and 180 (green) in seven different sediments from Lake Cochituate, Natick MA measured in laboratory-tumbled polyethylene pieces and in extracted porewater (Apell and Gschwend 2014). The polyethylene measurements were converted to porewater concentrations using K_{PEw} values. The solid line represents the 1:1 relationship and the dashed lines represent the calculated root mean square error of 0.23.

Finally, a comparison of PE passive sampling results with EqP-type calculations was performed (Apell and Gschwend, 2014). In this case, the data from each method was compared to porewater concentrations found by using PE in a solid phase extraction mode from a sediment slurry (after Lohmann et al., 2005). This approach enabled detection of the larger PCBs in the pore water. In every case, the *ex situ* passive sampling results, corrected using the expanded PRC set, matched the equilibrium results extremely well (Figure 17). In contrast, use of the sediment concentration data that was normalized by $f_{oc}K_{oc}$ was typically an order of magnitude too high. Using a K_d value in the EqP approach that included an estimate of the impact of black carbon content (f_{oc} was $19.0\% \pm 0.2\%$ ($n = 5$), BC content was of $1.15\% \pm 0.22\%$ ($n = 5$), and K_{BC} values taken from Koelmans et al. 2006), the EqP approach was much improved, although still much less accurate than the passive PE sampling method. Summing the results for all nine PCB congeners and comparing shows the results from PE passive sampling method was indistinguishable from the equilibrium result, while the EqP method only gets close if sorption to black carbons is considered (Table 7).

Hence, we conclude that the PE passive sampling approach, when used with an appropriate array of PRCs, can obtain accurate porewater concentration data. Arguably, any *ex situ* approach, whether using analysis of porewater extracts, passive samplers, solid-phase extractions, or even sediment analyses, may suffer inaccuracy due to the possibility that samples returned to the laboratory will not necessarily reflect the porewater in the field if processes are acting to flush it at significant rates.

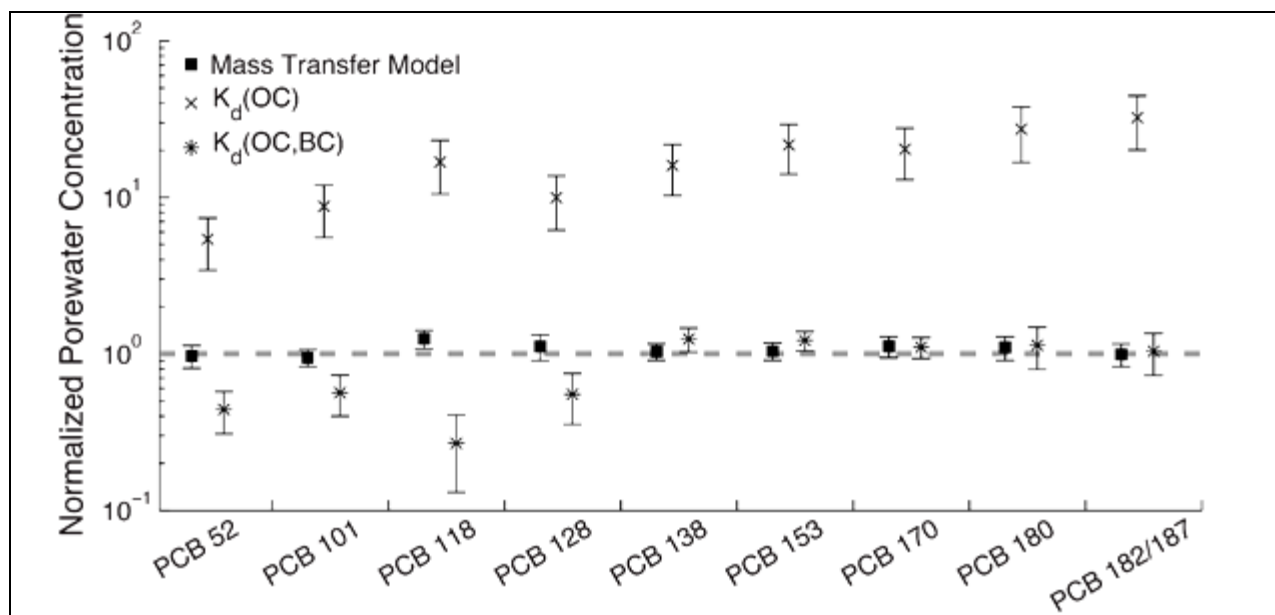

Figure 17. Porewater concentrations deduced from the equilibrated PE (dashed line) compared with (a) the passive sampling results (squares), (b) the equilibrium partitioning model accounting for only organic carbon (x) and (c) the equilibrium partitioning model accounting for both organic and black carbon (*). Figure from Apell and Gschwend (2014).

6.2 Performance Objective: Demonstrate PE Passive Sampling Is Effective for Site Mapping.

The PE passive sampling technology offers several advantages. First, since risk assessments commonly involve food web modeling, the investigator commonly needs data on contaminant concentrations in pore water (and overlying waters). Based on the results described in the preceding section, such data are not accurately known by using sediment concentrations and K_d estimates from $f_{oc}K_{oc}$. Next, since the extent of contamination in sediments is a key factor in designing clean up approaches, one needs an effective way to map the relevant contaminant levels controlling risks. Finally, as such investigations involve substantial costs, one would like to enable data-gathering phases of the work to be performed as cost-effectively as possible. The following describes this project's findings with respect to these issues.

Table 7. Estimated porewater concentrations for the sum of nine PCB congeners using four approaches (Apell and Gschwend, 2014).

Method	Σ ninePCBs $\pm 1\sigma$
equilibrium value	0.37 \pm 0.03
passive PE sampling with PRCs	0.38 \pm 0.02
EqP with $K_d = f_{oc}K_{oc}$	5.0 \pm 1.8
EqP with $K_d = f_{oc}K_{oc} + f_{BC}K_{BC}(C_{porewater})^{0.7}$	0.29 \pm 0.03

First, one can use *in situ* PE passive sampling data to generate maps of the contaminant distributions of sites of interest (Figure 18). Traditionally, this has been done using sediment concentrations (Figure 18 left), but efforts to translate these concentrations into biota exposures and uptake are likely inaccurate if one accepts the inability to connect such information into chemical activities or fugacities. (Said another way, we don't *a priori* know how to accurately get K_d 's and BSAFs.) If one accepts that porewater (and water column) concentrations are most suited to calculating sediment bed-to-water column fluxes and biota exposures, then the PE passive sampling map (Figure 18 right) would be much more useful to the assessment and remediation processes.

This latter point can be emphasized by comparing Σ PCB sediment concentration maps from the demonstration site using three different types of data. First, using current practice, one can measure Σ PCBs in the sediments at the site, and find the entire site is >1 ppm Σ PCBs, and about $1/3^{\text{rd}}$ of the area in >2.5 ppm (Figure 19 left). However, using those same sediment samples to extract porewater samples, analyze those waters for PCBs, and then estimate "bioavailable" PCBs using $C_{\text{porewater}} \times f_{\text{oc}}K_{\text{oc}}$, one finds a very different map (Figure 19 middle). In this case, all of the site acts like Σ PCBs is <0.5 ppm and about $2/3^{\text{rd}}$ of the area is less than 0.25 ppm.

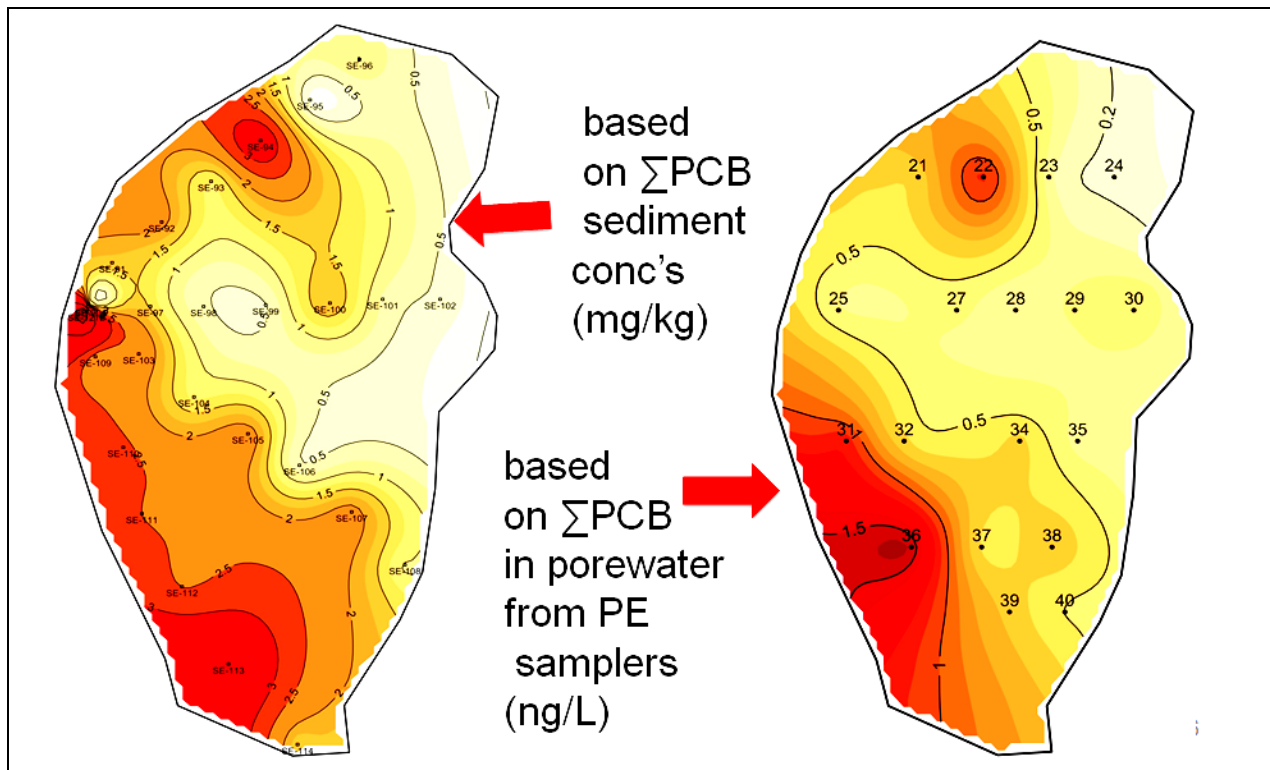

Figure 18. Comparison of maps of total PCB concentrations from (left) sediment concentrations (mg/kg dry weight) measured from 50 samples before dredging at the site began and (right) porewater concentrations (ng/L porewater) obtained using results from 18 *in situ* PE passive samplers obtained during round 3 of this project after targeted dredging (see Figure 8 yellow and green areas). The highest sediment concentration contours encompass areas (indicated in red on left panel) with more than 2.5 mg Σ PCBs/kg sediment, while the highest porewater concentration contours at more than 1 ng Σ PCBs/L porewater highlight the most contaminated

areas (indicated in red on right panel).

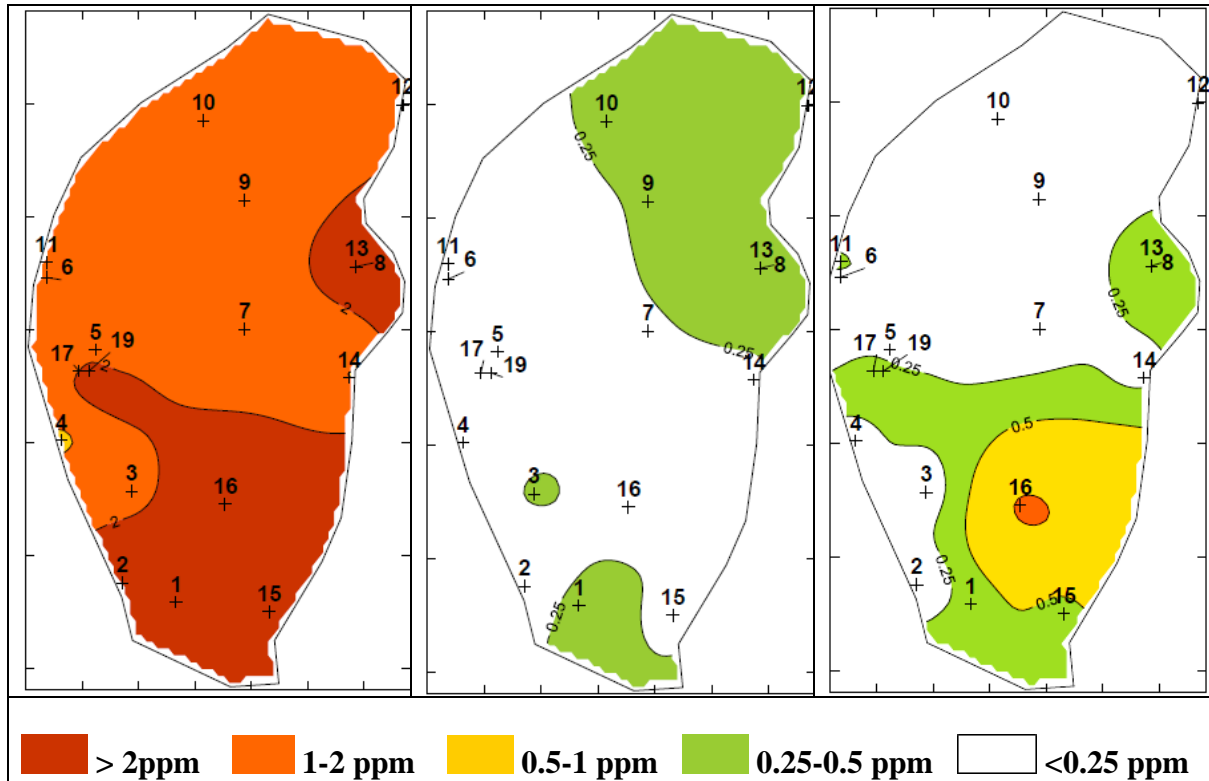

Figure 19. Contour maps of Σ PCBs from data obtained in sampling rounds 1 and 2 indicating PCB concentrations in sediments based on: (left) direct analysis of C_{sediment} (contour shown separates >2 ppm from 1 – 2 ppm areas), (middle) direct analyses of porewater samples which are subsequently used to estimate sediment concentrations by $f_{oc}K_{oc} \times C_{\text{porewater}}$ (contour shown separates $>0.25-0.5$ ppm from <0.25 ppm areas), and (right) indirect estimation of porewater concentrations using PE passive sampling ($C_{\text{porewater}} = C_{\text{PE}}/K_{\text{PEw}}$) and then estimating sediment concentrations by $f_{oc}K_{oc} \times C_{\text{PE}}/K_{\text{PEw}}$. If porewater concentrations reflect "bioavailable" portions of sediment concentrations, then one may readily see stark differences between use of total sediment concentrations as opposed to sediment concentrations deduced from porewater concentration information.

A similar pattern is seen for the map generated using the PE passive sampling results (Figure 19, right) where now $C_{\text{porewater}}$ is deduced from $C_{\text{PE}} / K_{\text{pe-water}}$. Again, almost all of the site appears to have Σ PCBs <0.5 ppm (only station 16 in the southeastern part of Pegan Cove appears to have elevated Σ PCBs (between 1 and 2.5 ppm). The discrepancy could involve some combination of the inaccuracy of estimating K_d using $f_{oc}K_{oc}$ (see previous section) and the recognition that lake water is infiltrating at some locations of this site due to nearby groundwater pumping. The bottom line is, if we want to accurately characterize the risks to the food web, then we need to start with data that reflect "chemical activities" or "bioavailabilities". Porewater concentration

data offers a huge advantage in this regard, and comparisons to sediment mapping suggest the use of sediment data do not yield the same understanding of risk.

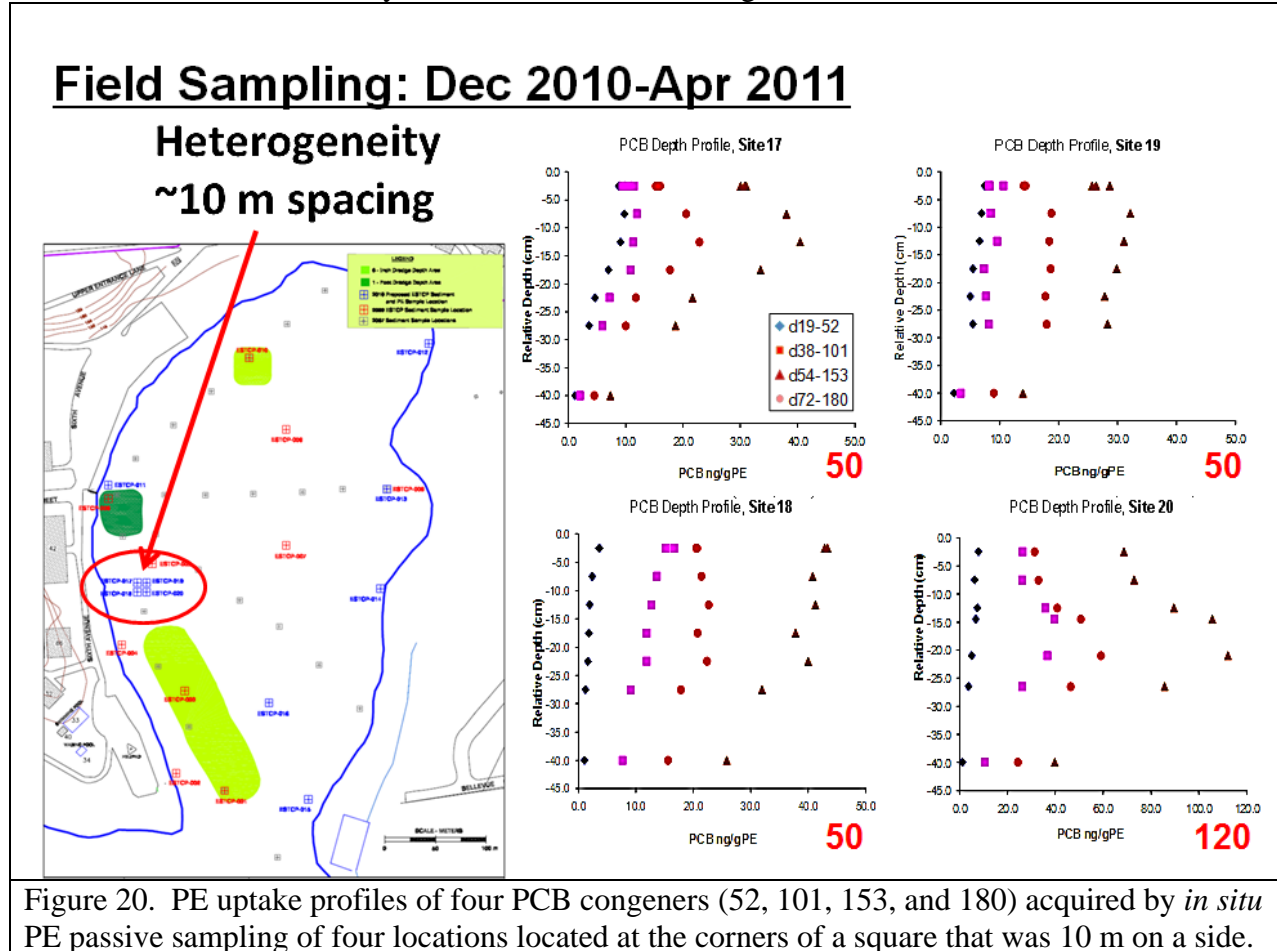
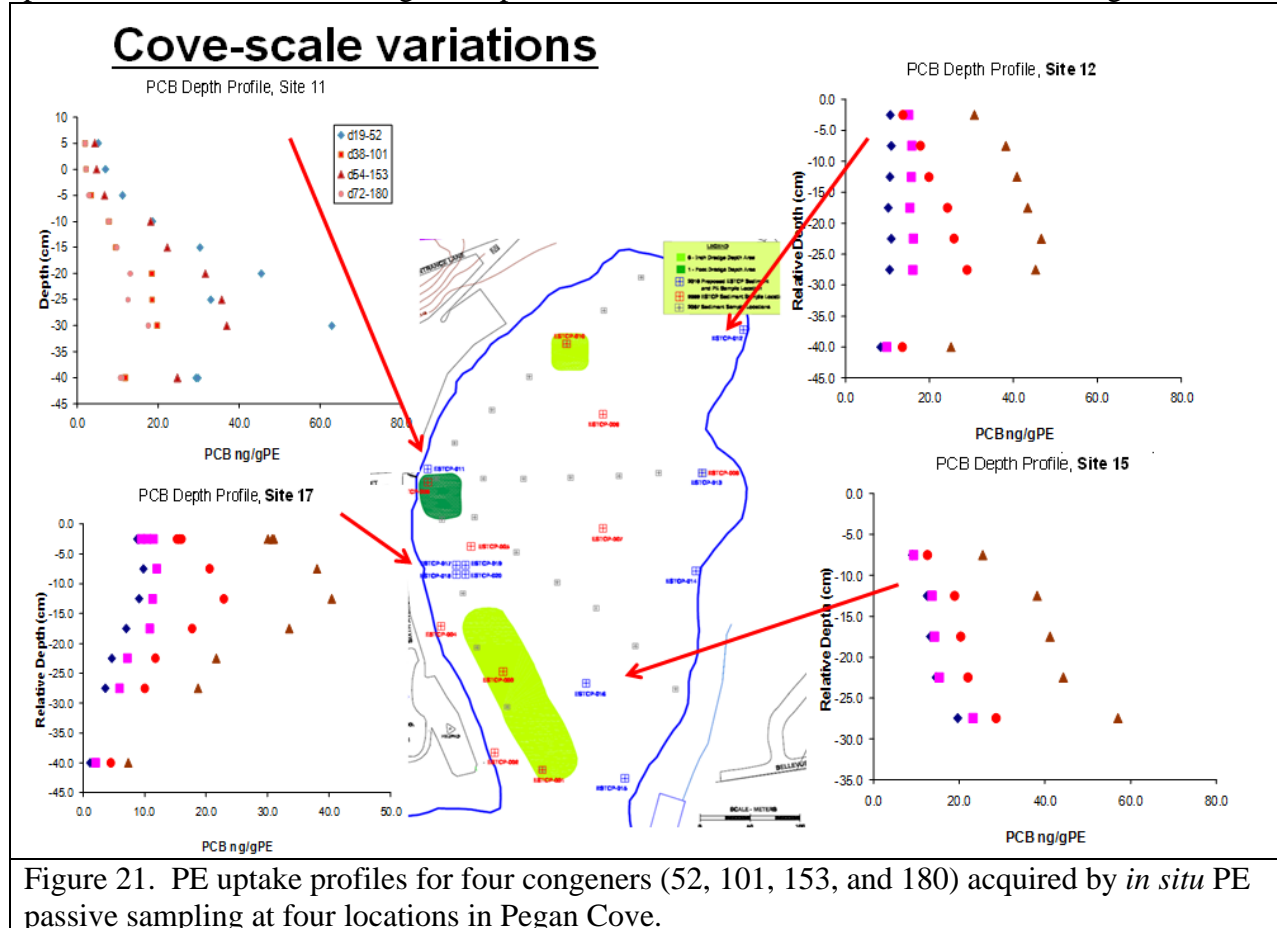

Figure 20. PE uptake profiles of four PCB congeners (52, 101, 153, and 180) acquired by *in situ* PE passive sampling of four locations located at the corners of a square that was 10 m on a side.

Next, *in situ* PE passive sampling allowed a three-dimensional delineation of the extent of contamination. To this end, we have used PE passive samplers to look at concentration profiles at our demonstration site. Using such data, one can see evidence of the spatial heterogeneity at a given site. Focusing on a location that was about 75 m from the most contaminated location at our demonstration site, we saw that four PE samplers all showed significant presence of major PCB congeners (nos. 52, 101, 153, and 180; Figure 20) throughout those samplers' lengths. But despite these samplers' close proximity to one another, the peak concentrations seen were not always at the same depths. For example, site 20 (lower right sampler in Fig. 20) had more than twice the peak concentrations of congener 153 as the other three nearby locations. Also, the shapes of the profiles with depth varied, with only two of them having clear subsurface maxima. Nonetheless, all the profiles suggest significant contamination down to about a foot (30 cm).

Likewise, we deployed the *in situ* PE passive samplers at locations spread around the demonstration site (Figure 21). Perhaps not surprisingly, the PE sampler uptake of PCB 153 (a major component of the Aroclor 1260 spilled at this site) resulted in similar PE concentrations of ~ 40 ng/g_{PE} throughout the cove. This implies that sites distributed throughout the Pegan Cove area have similarly bioavailable PCB 153 despite very different sediment concentrations.

Hence, in addition to characterizing the lateral extent of contamination, the PE samplers can provide data suited to defining the depth of contamination without the need for coring and later



disposal of contaminated sediments.

Finally, we note that these field surveys were accomplished at virtually the same costs as would be required for the current practice of sediment sampling. This aspect is discussed in more detail in the Cost Performance section below. Also, this demonstration project has allowed us to develop and improve SOPs for preparing, deploying, and analyzing the PE passive samplers and guidance for performing the data calculations with the PRCs. These SOPs and the PRC Correction Calculator are available on-line at the ESTCP website (Gschwend et al., 2012a, 2012b, 2012c, and Tcaciuc et al. 2014).

6.3 Performance Objective: Demonstrate PE Passive Sampling Is Suited to Long Term Monitoring (LTM) After Site Remediation

The *in situ* PE passive samplers can also be used for long term monitoring (LTM) of a contaminated site. Unlike the current practice of using organisms like mussels, PE samplers can

be deployed at site locations that would be hazardous to the biomonitors, including in the sediment beds. Also the properties of the PE do not change during the deployment like lipid

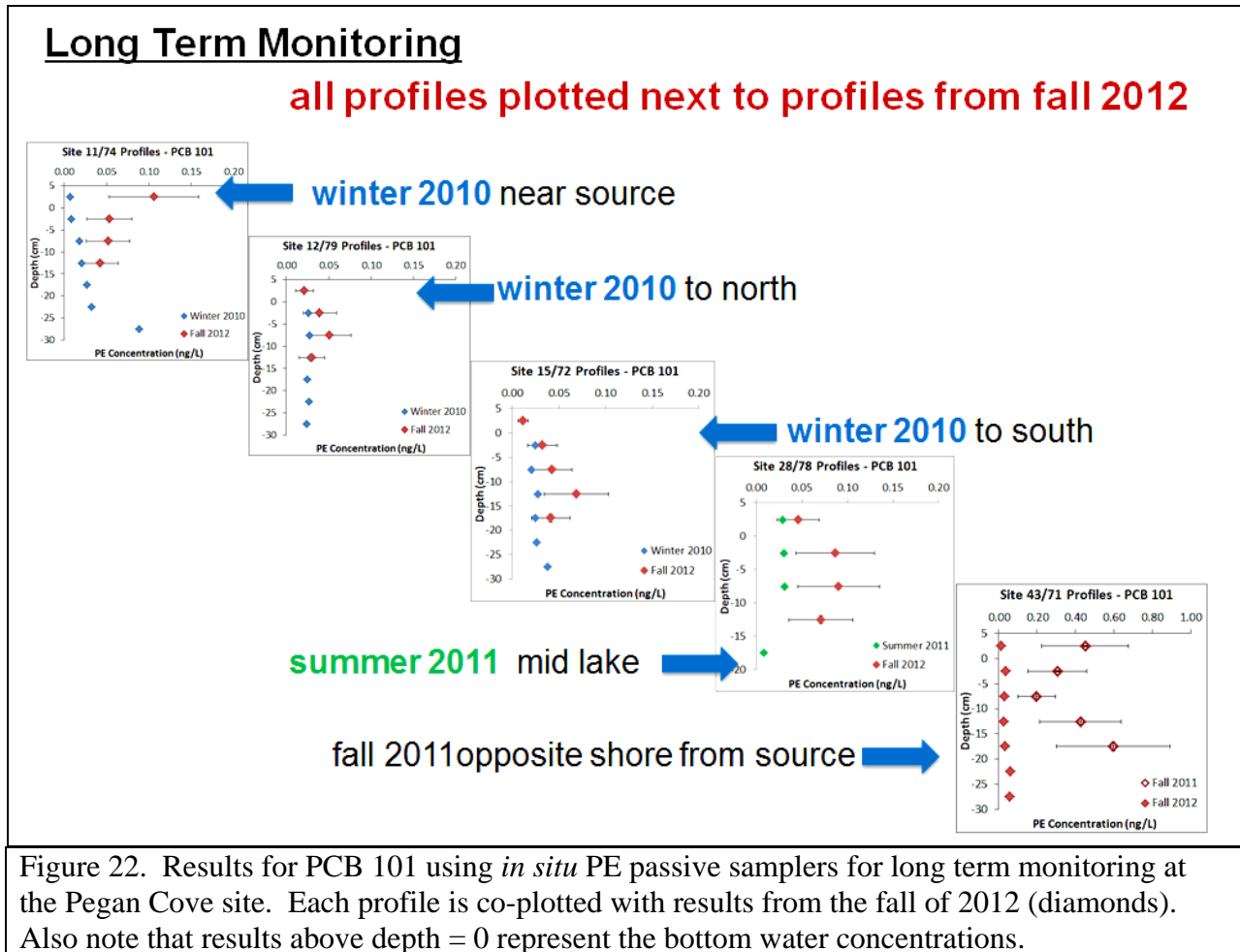

contents of mussels have been seen to do. Finally, the PE samplers can be deployed in any season, as one can correct diffusivities and partition coefficients for effects of temperature.

The PE samplers also enable measurements of both the pore water and the overlying bottom water, a useful combination in LTM (Figure 22). For example, one sees increased PCB 101 presence in the bottom water at site 11 at our demonstration site in the fall of 2012 as compared to the winter of 2010 as well as at site 43 in fall 2012 compared to fall 2011. As we believe this demonstration site experiences substantial time-varying lake water infiltration into the sediment bed in response to seasonally variable groundwater pumping (see Appendix C), such changes in porewater concentrations over time may not be surprising. Nonetheless, one can use such pore water and bottom water concentrations to ascertain whether risks to biota in the area are substantially changing.

Likewise, the PE passive samplers can be used to evaluate the performance of sediment caps. Sand caps were put in place at the demonstration site in 2010 where it had been dredged (Figure

8). A year after cap placement, the bottom water concentrations of PCBs 101 and 153 were near 5 pg/L (Figure 23). It also appeared that those concentrations increased as one moved deeper into the cap. This could mean there is diffusion upward through the cap, or that the cap

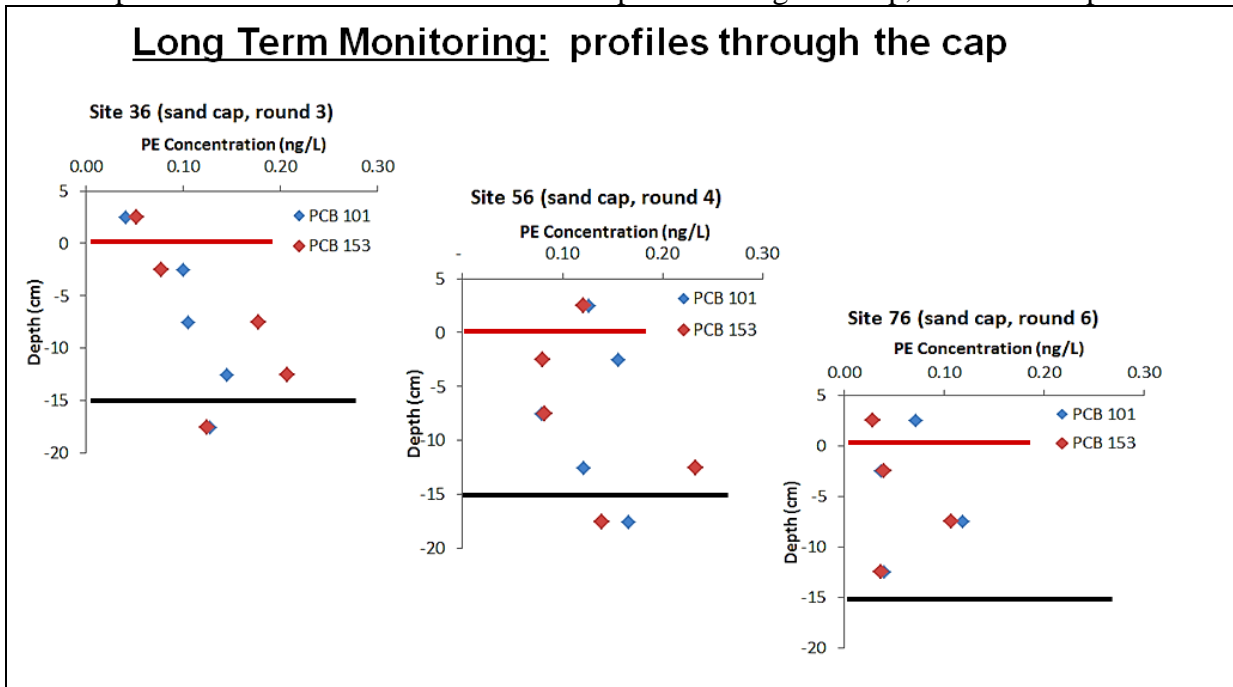

Figure 23. *In situ* PE passive sampling observations through sand caps at Pegan Cove in sampling round 3 (June 2011), sampling round 4 (November 2011), and sampling round 6 (November 2012). Red lines indicate location of bed-bottom water interface, while black line indicates putative bottom of the sand cap.

contained increasing amounts of contaminated sediment mixed into its deeper layers. Six months later, the cap was assessed at a location somewhat south of the first sampling. At this time and place, the bottom water concentrations were near 10 pg/L and these did not clearly increase with depth into the cap. Finally, returning to the cap in November 2012, the bottom water concentrations were below 10 pg/L, and the pore water in the cap did not exhibit elevated concentrations. Again, these data may simply indicate that the sand cap initially included some contaminated sediments which over time were leached by infiltrating lake water. As of November 2012, there was no strong evidence for a gradient driving PCB diffusion out of these cap locations.

To sum, these initial stages of LTM were readily completed using passive samplers. Bottom water concentrations of individual PCBs do not appear to be increasing, although the data only reflect a few years after the site's sediments were dredged and capped. There is no clear increase in porewater concentrations at either un-remediated sediment locations or in the sand caps.

6.4 Performance Objective: 4. Demonstrate PE Passive Sampling Commercially Viable Based on QA/QC Metrics, Ease of Use, and Costs

An important goal of this project involved efforts aimed at showing the commercial viability of the PE passive sampling methodology. To this end, several interactions were pursued.

First, the project was performed in collaboration with colleagues from ICF International, a "commercial" entity. Their involvement insured oversight of the activities so that everything would be compatible with commercial approaches. Notably, ICF International participants led the field sampling efforts and the cost performance assessments.

Second, we involved an environmental contract laboratory, Pace Analytical, in the program. Colleagues at Pace helped iron out key methodological choices such as which compounds to use as PRCs so as to avoid interfering with surrogate and injection standards used in standard protocols (e.g. EPA Method 1668 for congener specific analysis of PCBs). As part of our effort to demonstrate the accuracy of the MIT lab's measurements, we split PE samplers with Pace for their analyses. As a side result, Pace demonstrated that a contract lab can readily perform PCB congener specific analyses of PCBs on PE samples. In addition, we prepared SOPs to facilitate adoption of methods of PE preparation and analysis (Gschwend et al 2012a and 2012c).

Finally, we established method QA/QC parameters allowing commercial planning of PE passive sampling implementation. First, using our typical PE sample sizes (1 mil sheet cut to 5 cm long and 5 cm wide yielding about 60 mg of PE) and final extract volumes (~100 uL), for PCB analyses using high resolution capillary chromatography combined with low-resolution mass spectrometry, the detection limits are near 1 pg/L for individual PCBs and PAHs (Appendix F). Notably, the SOP for PE preparation (Gschwend et al. 2012a) gives guidance on how to make the PE samplers so as to accomplish the necessary sensitivities.

At no time did a trip blank sampler show detectable PCB contamination corresponding to >1 pg/L_{water}.

Next, we showed that the precisions associated with PE-inferred porewater concentrations are dependent on the site of interest and the investigator's choice of sampling duration. Working with Pace Analytical, we found the two labs measured PCBs in PE strips incubated in our site's sediments to within a factor of 2 for #52, 50% for #101, 30% for #153, and 10% for #180 (Appendix G). Hence, lab-to-lab variations will be the source of some variability. But within a single lab, Fernandez et al. (2009b) and Apell and Gschwend (2014) show relative standard deviations on resultant porewater concentrations, correcting for surrogate recoveries and after PRC adjustments, are generally better than a factor of two.

More importantly, our work has found that use of the PE passive sampling approach yields porewater concentration accuracies that are much better than current EqP (Follett 2011; Gschwend et al., 2011, Apell and Gschwend, 2014).

Perhaps the only key remaining issue limiting the ability of commercial entities to adopt PE passive sampling of pore waters is that the regulations are still written and enforced in terms of total PCBs in sediments (or biota). Hence, the commercial entity must utilize methods that allow them to translate the PCB analyses of the PE into such metrics for the regulators. This can be done in various ways. First, since the PE measures can be directly converted to concentrations in

pore water, then perhaps water quality standards could be applied to assess such pore water results (Σ PCBs Maximum Contaminant Level (MCL) in drinking water = 0.5 ug/L). Alternatively, one may use the porewater concentrations to estimate equilibrium (lipid normalized) tissue concentrations (e.g., Gschwend et al., 2011); regulators could use such tissue concentration results to estimate risks to humans who consume such shellfish or finfish. Finally, this latter process may require employing a food web model which is driven by measures of contaminants in the water column and pore water (not sediment) to estimate tissue concentrations in biota of interest.

7.0 COST ASSESSMENT

This section provides a summary of the cost comparison between the use of passive PE samplers and traditional sediment sampling techniques. Information from several field sampling and analytical events conducted during this project was used in the development of this cost comparison.

7.1 COST MODEL

This section presents a simple cost model that reflects the cost elements that would be required for implementing the PE sampling technology at a real site. A description of the site background, sampling methods compared, and each cost element are provided. A detailed cost model and breakdown of the passive PE versus traditional sampling method costs are provided in Appendix H.

Site Background. The site chosen for the passive PE sampling technology demonstration was the southern portion of Lake Cochituate (specifically Pegan Cove) in Natick, Massachusetts. Pegan Cove has a water surface area of approximately 33 acres with water depths ranging between 0 and 10 feet. The cove is used for recreational purposes including swimming, fishing, and water skiing. A local water skiing club installs a slalom course across the middle of the cove during the summer months.



Sediment within the demonstration site study area varies from sand to finer grained silts and clays. Nearshore sediments tend to consist of a larger percentage of sand, due to winnowing of the finer-grained sediment from shallow water wave action. In the deeper waters (e.g., greater than 5 feet), sediments tend to consist primarily of organic-rich silts and clays. The sediment bed thickness across the study area ranges from approximately 3 to 16 inches and overlays a layer of peat material. Sediment within the study area contains concentrations of PCBs ranging from non-detect to less than approximately 5 ppm.

Sediment Sampling Methods. Traditional sediment sampling techniques performed in Pegan Cove during the demonstration period included the use of a petite ponar grab dredge, an Eckman box dredge, and sediment coring. We used a 6" x 6" petite ponar grab dredge which can collect a grab sample of sediment to a depth of up to approximately 6 inches (15.2 cm), and is very similar

to the Eckman box dredge. The ponar and Eckman dredges are very common sediment sampling techniques because they can be used in a variety of aquatic conditions and follow relatively simple procedures. Because the ponar grab dredge is one of the most commonly used sampling techniques, we have used it to represent the “traditional” sediment sampling method in our cost comparison with the passive PE technique. Sediment core sampling can also be performed in a variety of conditions; however, the complexity of the techniques can vary significantly. Techniques can vary from relatively expensive barge- or boat-mounted mechanical rig methods (e.g., vibracoring) to less expensive polycarbonate plastic tubes that are manually-driven into the sediment bed. Since the costs associated with core sampling can vary significantly, it was not evaluated as part of this cost assessment.

Passive PE sampler deployments and ponar dredge sediment sampling were performed at various locations within Pegan Cove and at various times of the year during the demonstration period (see Table 2). Both sampling techniques were conducted from a small aluminum skiff equipped with an electric trolling motor. All costs developed in this report are based on sampling in a fresh water lake setting.

Cost Elements. The costs associated with passive PE sampler deployment and ponar dredge sampling were broken down into the following five cost elements:

- **Expendable items:** including materials such as stainless steel mixing bowls/spoons, decontamination supplies (buckets, brushes, distilled water, detergent), Nitrile gloves, aluminum foil, plastic sheeting, rope, paper towels, garbage bags, bubble wrap, Ziplock bags, and ice.
- **Non-expendable items:** including materials such as the ponar dredge, PE frames and hardware, sink rope, vehicle rental, and handheld GPS rental.
- **Field labor:** developed from actual field events for PE deployment and ponar dredge sampling. We assumed field campaign involving the collection of 12 traditional ponar dredge sediment samples and 12 PE samples.
- **Sample shipment:** costs based on FedEx priority overnight shipping from a FedEx drop off location near the demonstration site in Framingham, Massachusetts to a contract analytical laboratory in Minneapolis, Minnesota (Pace Analytical). This is the commercial laboratory which was used for both sediment and PE analyses during the project. Shipment costs also include packing tape to secure sample coolers.
- **Analytical costs:** include average per sample costs charged by commercial laboratories for PCB analysis via EPA Method 1668A for sediment and PE samples (average of unit costs provided by Pace Analytical and AXYS Analytical). Also includes costs for PE preparation supplies (e.g., PE strips, solvents, labeled performance reference compounds [PRCs], surrogates, glassware, nitrogen), and labor associated with PE preparation (e.g., cutting, cleaning, and PRC loading of PE) and calculating PRC corrections.

Costs that were equally associated with both sampling techniques were not included in the cost analysis. These included costs such as the preparation of planning and health and safety documents, the use of a boat, personal protection equipment (PPE), permitting, baseline characterization (i.e., hydraulic or bathymetry assessment), and reporting.

A percent cost savings by using the PE sampling method instead of the traditional ponar dredge method was calculated using the following equation:

$$\% \text{ Savings} = \frac{\$ \text{ Traditional Method} - \$ \text{ PED Method}}{\$ \text{ Traditional Method}} * 100\%$$

7.2 COST DRIVERS

Cost drivers are those costs that should be considered when selecting the PE sampling technology for future implementation. The costs to execute a sediment sampling program using PE samplers will vary to a degree from site to site. The key cost drivers are discussed below along with a brief discussion of their impact on cost.

Fresh Water versus Marine Environment. Costs under this demonstration study were developed based on sampling in a fresh water environment using PE samplers constructed of aluminum material using zinc-coated hardware. Sampling in a marine environment could potentially increase the material costs for the PE frame and hardware if corrosion resistant materials (e.g., stainless steel) are required. PE samplers made of various materials have been successfully deployed and retrieved by us in freshwater, brackish, and saltwater environments (e.g., Boston Harbor and United Heckathorn Superfund Site in San Francisco Bay, California).

Water Depths. Costs under this demonstration study were developed using PE deployment equipment designed specifically for water depths of less than 20 feet, working from a small skiff, and in an area with only wind driven water currents. If it is anticipated that water depths could be greater than 20 feet, it may be necessary to find other deployment and retrieval options, such as using certified divers to install the PE samplers by hand or using a larger boat to increase stability when installing the PE samplers. The use of certified divers would increase labor costs, and the use of a larger boat would increase labor and fuel costs, as well as increasing nonexpendable item costs.

River or Tidal Currents. Some sites may be situated within river or tidal areas that have slow- to fast-moving currents. If this is the case, a larger boat may be required to provide more effective anchoring which could increase labor and fuel costs. Water currents could also increase the level of difficulty for field personnel with the PE deployment and retrieval process which could increase labor costs.

Site Access. Site access complexity can increase project costs significantly. If straightforward access to the site is not available, it may require field teams to physically carry supplies to the site and sampling locations. This would increase labor costs by increasing field deployment times. There would be significantly more equipment to transport using traditional sediment sampling equipment compared to PE samplers. Traditional sediment sampling equipment would include items such as decontamination fluids, stainless steel mixing bowls and spoons, sample bottles, ice for samples, and paper towels, while PE sampling equipment would include a roll of sink rope, the assembled PE samplers, and the deployment tool.

Investigation Derived Waste (IDW). Investigation derived waste (IDW) is waste that is generated from field investigation activities at a potentially contaminated site. It can include both solid wastes (e.g., Nitrile gloves, plastic sheeting, aluminum foil, etc.) and non-hazardous/hazardous wastes (excess sediment, decontamination fluids). There is not expected to be a big difference in solid waste disposal costs between the traditional sampling techniques and the PE samplers, but there could be a significant difference in non-hazardous/hazardous waste disposal costs if certain sites require it. Non-hazardous/hazardous waste generated from PE samplers is expected to be minimal and might possibly include segments of sink rope which could have absorbed contaminants from being submerged in the sediment. Traditional sediment sampling, however, could generate larger volumes of contaminated sediment depending on the number of sampling locations. Typically, there is an excess volume of sediment left over after the sediment has been homogenized and sample containers have been filled. Depending on site requirements, this sediment may have to be containerized and disposed of separately as either a hazardous or non-hazardous waste. Additionally, decontamination fluids associated with traditional sediment sampling may require special handling and disposal. These disposal costs would increase the overall cost of traditional sediment sampling, including added labor responsibilities.

Rental Equipment versus Purchasing Equipment. It is difficult to evaluate the cost/benefit of renting PE samplers versus purchasing them because the sampling device and sampling protocols have not yet been commercially developed. Several options for acquiring PE samplers might include:

- The analytical laboratory owns the PE sampler and assembles them at the laboratory, including loading the PRC-impregnated PE strip into the frame. The laboratory would then ship the samplers to the client, similar to the current practice of delivering sample containers and soil sampling devices (e.g., Encore soil samplers). The client would then ship the entire PE sampler back to the laboratory once they are retrieved from the water body. The cost of the PE sampler would likely be incorporated into unit analytical costs or as a separate sampling device charge. The cost charged by the laboratory could fluctuate based on the number of PE samplers ordered.
- The user of the PE samplers (e.g., environmental consulting firm, government agency, corporation, university, etc.) could purchase their own materials from suppliers and assemble the samplers themselves following the SOPs provided in Appendix B. The PRC-impregnated PE strip would be delivered by the analytical laboratory to the user, who would in turn load the PE into the sampler frame prior to deployment.
- Renting PE samplers from a local environmental equipment rental company. Under this option, it is likely that PRC-impregnated PE strip would need to be loaded into the frames by the user. The unit rental rates would be based on the number of samplers and length of rental period, much like most other environmental sampling equipment.

Equipment costs under this demonstration study were developed based on the capital costs of materials for both the PE sampler and the ponar dredge. The capital cost of 12 PE sampler aluminum frames, hardware, PE deployment tool, and 1,200 feet of sink rope was \$798, or approximately \$66.50 per PE sampler. Excluding the costs for the sink rope and PE deployment tool (which could be reused in future sampling programs), each PE sampler frame and associated

hardware was calculated at \$53 per PE sampler. The approximate capital cost for the purchase of a ponar dredge is \$810 (based on a 2013 price from Cole Palmer).

As PE samplers become commercially available, a more useful comparison would be the rental rates for PE samplers versus ponar dredges. The current rental rates for a ponar dredge (and Ekman dredge) are approximately \$20 per day, \$60 per week, or \$180 per month (based on 2014 prices from U.S. Environmental Rental Corporation, <http://usenvironmental.com/soil/dredges/>). Since environmental rental companies do not currently offer PE samplers for rental, it is difficult to anticipate what their daily, weekly, or monthly rates would be. However, based on the relatively low material and construction costs for the PE frames and deployment tools, it is likely that renting a set of dozen PE samplers would be comparable, and possibly less than, the cost of renting a ponar dredge.

7.3 Cost Analysis

The cost analysis presented below has been broken down into the five cost elements discussed above including: expendable items, non-expendable items, field labor, sample shipment, and analytical costs. The cost analysis was developed based on actual expenses and labor hours incurred during numerous field sampling events performed under this demonstration project. Costs were developed based on the assumption that 12 samples would be collected following both traditional sediment sampling procedures using a ponar dredge and sampling with the use of PE samplers.

Table 8 summarizes the total costs incurred for each cost element, including the percent cost savings of using the PE sampling method over the traditional ponar dredge method. A detailed cost model and breakdown of the passive PE versus traditional sampling method costs are provided in Appendix H.

Table 8. Cost comparison of PE samplers and traditional sediment sampling technique.

Cost Element	PE Sampling Technique Cost	Ponar Dredge Sampling Technique Cost	% Cost Savings of PE Technique
Expendable Items	\$37	\$169	78%
Non-Expendable Items	\$948	\$960	1%
Field Labor	\$1,240	\$1,530	19%
Sample Shipment	\$104	\$243	57%
Total Field Sampling Cost	\$2,330	\$2,902	20%
Total Analytical Cost	\$11,022	\$10,080	-9%

Notes:

Comparison assumes collection and analysis of 12 traditional sediment samples with a ponar dredge and 12 PE sampler deployments. Detailed assumptions for each cost element are described in Appendix H.

Expendable Items. Expendable items include those materials that are designed to be used only once and then discarded following each sampling event. Generally speaking, these items include materials used for the homogenization of sediment samples and for the decontamination of sampling equipment. The detailed cost breakdown provided in Appendix H lists the specific expendable items used in developing these costs.

When performing traditional sediment sampling procedures, cross contamination can often become an issue of concern if proper decontamination procedures are not followed. The calculated percent cost savings related to expendable items for the PE sampling method is 78 percent (\$169 for ponar dredge sampling versus \$37 for PE samplers). This savings is contributed largely to the fact that PE samplers do not require decontamination of field equipment or the transfer of sample media from a sampling device to a sample container, as is the case with traditional sediment sampling. Rather, the PE sampler is retrieved from the sediment bed, wiped gently to remove any excess adhered sediment, wrapped in aluminum foil, and shipped directly to the laboratory for analysis. In some cases, the PE is removed from the PE sampler frames, placed in a laboratory-provided container (e.g., vial, bottle), and then shipped or hand-carried to the laboratory for analysis.

As shown in Appendix H, there are 15 expendable items involved in traditional sediment sampling, while there are only five expendable items included for the PE samplers. For traditional sediment sampling, the expendable item costs appear to be spread amongst a variety of items and there is no single item which holds a significant percent of the total costs.

Non-Expendable Items. Non-expendable items are designed to be reused and include items such as the ponar dredge, the PE sampler frames and hardware, handheld GPS rental, and vehicle rental. The cost comparison for non-expendable items was developed based on the capital costs of purchasing a ponar dredge and the capital costs involved with constructing 12 PE samplers. The capital cost for purchasing a ponar dredge was obtained from a reputable supplier (Cole Palmer), while the capital cost for purchasing the aluminum PE sampler frame and associated hardware was obtained from the local metal fabricator used in constructing the PE frames for use in this demonstration study. Results show the cost savings related to non-expendable items for the PE sampling method was minimal (only 1 percent).

The costs involved in this category are difficult to compare because even though both sampling apparatus can be purchased at a unit price, the ponar dredge can collect an unlimited amount of samples while the PE sampler is only useful for one sample at a time. In addition, a ponar dredge can be rented on a daily, weekly, or monthly basis instead of purchasing one. Since the PE samplers have not been commercially developed yet, rental costs cannot be calculated and compared. However, based on the material costs of both procedures, it is believed that rental costs for one dozen PE samplers could be comparable to the costs of renting a ponar or Ekman dredge. Since the percent difference in non-expendable costs associated with the two sampling methods is only 1 percent, this cost element is considered negligible as it relates to the overall cost analysis.

Field Labor. This category compares the number of field labor hours required for two field personnel to collect 12 sediment samples following traditional sediment sampling procedures

using a ponar dredge and the field labor hours required to install, retrieve, and process 12 PE samplers. The labor hour estimates for both methods include the time to pack samples into coolers and prepare the coolers for overnight shipment to the analytical laboratory. The hourly estimates are derived from several field events during this project where either sediment was collected using a ponar dredge or PE samplers were installed/retrieved. As part of the project, traditional sediment samples were collected and documented during separate events in November 2009, December 2010, June 2011, and October 2012. PE samplers were installed during separate events in December 2010, May 2011, October 2011, November 2011, and October 2012 (Table 2).

Labor hours for an equipment manager have also been included in the field labor cost element. This person is typically involved in the mobilization/demobilization phases of a sampling event where he or she gathers the required sampling equipment which will be used in the field. This person is trained in the operation and maintenance of field equipment and is familiar with the required equipment needs for various standard environmental sampling techniques. The estimated hours are based on the equipment manager's effort to mobilize and demobilize field equipment, vehicles, PPE, and health and safety equipment. These hours will vary depending on the size of the field sampling event and other variables. The hours estimated in this cost analysis are based on the actual field events performed on this project.

The equipment manager labor hours incorporated into the PE sampling cost include estimated hours for him/her to assemble the PE sampler frames with the PRC-impregnated polyethylene strip. This assumes that the protocol calls for the analytical laboratory to ship only the PRC-impregnated polyethylene strip to the client and the client is responsible for assembling the PE sampler frame. If the protocol calls for the analytical laboratory to assemble the PE sampler frames, then the equipment manager labor hours would be reduced by half.

The PE sampling labor hours used in the cost comparison are for two mobilizations. The first mobilization includes 4 hours to install 12 PE samplers. The second mobilization includes a total of 6 hours to retrieve those same 12 PE samplers, remove the PE strip from the sampler frame, place the PE strips into sample containers, and pack the containers in a cooler for shipment to the laboratory.

The traditional sediment sampling labor hours used in the costing are for one mobilization. A conservative estimate of 60 minutes per sample was used to collect the sample, homogenize the sample, place in a sample container, decontaminate the equipment, and pack the samples in a cooler with ice for shipment to the laboratory.

Sample Shipment. This category compares the cost of shipping 12 PE samples with the cost of shipping 12 traditional sediment samples. Since a standard PE sample shipping protocol has not yet been established and could vary depending on the particular project, the PE sample shipping cost used in this analysis is based on shipping the PE strip after being removed from the PE sampler frame in a standard sample cooler with no ice. The cost for shipping traditional sediment samples is based on standard sample shipping protocols.

Analytical requirements for sediment and PE samples, like most environmental sample media, often require the use of specialized accredited analytical laboratories. These accredited analytical laboratories are often not located locally to a project site, and thus require overnight shipping. The unit costs used in this cost comparison were generated by Federal Express for priority overnight shipping rates from a Federal Express facility located in Framingham, Massachusetts to Pace Analytical, an accredited analytical laboratory located in Minneapolis, Minnesota. This is the same commercial laboratory that was used during this project. Costs were calculated using a 10 pound cooler for the PE samples versus a 40 pound cooler for sediment samples. The cost savings of shipping PE samples versus sediment samples is 57 percent (\$243 for sediment samples versus \$104 for PE samples).

The difference in shipping costs between the two sampling methods is driven by the much lower weight of a PE sample versus a sediment sample, as well as the analytical requirement of having to cool sediment samples to less than 4 degrees Celsius, while PE samples do not currently require this. Even if future PE sample shipment protocols ultimately require the same sample temperature requirements as traditional sediment samples, the conservative 10 pound cooler assumed in our cost analysis for shipping PE samples would cover the added weight of ice in the cooler. Properly packing sediment samples also takes more time than packing a cooler full of PE samples due to having to wrap each sample jar in bubble wrap to avoid breakage during transport and purchasing/packing ice for the cooler to ensure temperature requirements are met.

Shipping costs for PE samples could be higher (but still less than shipping sediment samples) if the entire PE sample frame (with PE strip still installed) is shipped to the laboratory. The weight of the PE sample frame (including associated hardware) wrapped in aluminum foil used in this demonstration study was approximately 1.5 pounds. The weight of a typical 8-ounce sample jar filled with sediment is also approximately 1.5 pounds. Only one standard cooler, which weighs approximately 8 pounds, would be needed to ship each set of 12 PE or 12 sediment samples. However, if proper cooler-packing procedures are followed, the addition of ice can account for an additional 10 to 15 pounds to the weight of the sediment sample cooler, and thus result in a higher shipment cost than PE sample shipment.

Analytical Cost. The analytical cost comparison was based largely on an average unit cost for PCB congener analysis via EPA Method 1668A for both the sediment and PE sample analysis. Commercial laboratory costs were used to determine an average unit cost, and included \$680 per sample from Pace Analytical (for both the traditional sediment and PE sample analysis) and \$1,000 per sample from AXYS Analytical (for both the traditional sediment and PE sample analysis). Both of these commercial laboratories were subcontracted during this demonstration study to perform sediment and PE analysis. Therefore, an average unit cost of \$840 per sample was used in the cost comparison, for both the traditional sediment and PE sample analysis. It is feasible that appropriately-equipped government, academic, or research laboratories could also perform the PCB congener analysis, and potentially at a lower cost than commercial laboratories. However, since a key focus of this demonstration study is to advance the commercial viability of the PE sampling technique, commercial laboratory costs were used in the cost analysis.

In addition to the unit cost for PCB analysis, additional costs for PE preparation supplies, labor associated with PE preparation, and labor associated with calculating PRC corrections were

considered in the total analytical cost for PE analysis. PE preparation supplies were estimated at approximately \$62 per sample (based on MIT analytical laboratory costs) and included the material costs for the PE strips, solvents, labeled PRCs, surrogates, glassware, and nitrogen. The labor associated with PE preparation (including cutting, cleaning, and PRC loading of PE) was estimated at 1.5 hours per sample, while the labor associated with performing PRC corrections was estimated at 1 hour per sample (based on MIT analytical laboratory costs).

It is these additional PE preparation labor and supply costs that cause the total analytical cost of the PE samples to be approximately 9 percent higher than the traditional sediment sample analysis (\$11,022 for 12 PE samples versus \$10,080 for 12 traditional sediment samples). As the use of PE samplers becomes more widely acceptable in the industry, PE preparation and PRC loading will likely be performed at the commercial laboratories, rather than in an academic or research laboratory. The costs associated with PE preparation and PRC loading that are incurred by the laboratory will likely be passed onto the PE user, either in the form of a higher per sample analytical cost or as a separate preparation fee or surcharge.

Another potential cost impact that may be associated with the commercial analysis of PE samples could be method development costs. Some laboratories may not have the current capabilities to analyze PE, and could therefore pass along method development costs to the PE user. However, based on the analysis of PE by two reputable commercial laboratories in this demonstration study, the likelihood of laboratories passing this cost along to the user is low. Several laboratories are advanced enough and fully equipped to test a wide range of different media types, and many laboratories are eager to offer new services and bear the development costs associated with those new services. Additionally, the guidance document *Passive PE Sampling in Support of In Situ Remediation of Contaminated Sediments: Standard Operating Procedure for PE Analysis* prepared as part of this ESTCP project (Gschwend et al. 2012c) includes detailed procedures for the extraction and analysis of PE, and could be easily implemented by commercial laboratories, at a minimal cost.

Lastly, a common problem in the analysis of traditional bulk sediment samples is matrix interference. Sediment samples with significant matrix interferences may lead to difficulty in accurately quantifying target contaminant concentrations, and thus often require additional pre-analysis cleanup steps or analytical method modifications to mitigate the matrix effects. Depending on the severity of the interferences, commercial laboratories may apply additional fees or surcharges for the cleanup steps or method modifications. Matrix interference is not a concern with PE analysis, so additional cleanup and/or method modification costs would not be incurred.

7.4 Cost Assessment Summary

Results of this cost assessment indicate that overall field sampling costs using PE samplers is approximately 20 percent less than traditional sediment sampling techniques using a ponar dredge. The major driver for the cost difference is that the field labor associated with deployment and retrieval of PEDs, on average, takes less time than sampling with a ponar dredge. Additionally, the expendable equipment and shipping costs are significantly less for the PE sampling technique.

The total PCB analytical cost for PE samples is approximately 9 percent higher than traditional sediment sample PCB analysis. The major driver for this difference is that PE analysis requires additional costs for PE preparation supplies, labor associated with PE preparation, and labor associated with calculating PRC corrections that traditional sediment sample analysis does not require.

8.0 IMPLEMENTATION ISSUES

As part of this project, Standard Operating Procedures documents were developed describing (a) the preparation of polyethylene passive samplers, means for their deployments, and chemical analyses after their recovery (Gschwend et al., 2012a, 2012b, and 2012c). In addition, a graphic user interface, called the PRC-Correction Calculator (Tcaciuc et al. 2014) was developed based on the mass transfer model described in Fernandez et al. (2009b). This calculator substantially assists in the analysis of data for contaminants like PCBs, PAHs, or DDTs in PE samplers.

9.0 REFERENCES

- Adams, R.G., R. Lohmann, L.A. Fernandez, J.K. MacFarlane, and P.M. Gschwend. Polyethylene devices: Passive samplers for measuring dissolved hydrophobic organic compounds in aquatic environments. *Environ. Sci. Technol.*, 41, 1317-1323, 2007.
- Apell, J.N. and P.M. Gschwend. Validating the use of performance reference compounds in passive samplers to assess porewater concentrations in sediment beds. *Environ. Sci. Technol.* 48, 10301-10307, 2014.
- Arthur, C. L.; Pawliszyn, J. Solid phase microextraction with thermal desorption using fused silica optical fibers. *Anal. Chem.* 62, 2145-2148, 1990.
- Booij, K.; Smedes, F.; van Weerlee, E. M., Spiking of performance reference compounds in low density polyethylene and silicone passive water samplers. *Chemosphere* 46(8), 1157-1161, 2002.
- Cornelissen, G., O. Gustaffson, T.D. Bucheli, M.T.O. Jonker, A.A. Koelmans, and P.C.M. Van Noort. Extensive sorption of organic compounds to black carbon, coal, and kerogen in sediments and soils: Mechanisms and consequences for distribution, bioaccumulation, and biodegradation. *Environ. Sci. Technol.* 39, 6881-6895, 2005.
- DiToro, D. M., C. Zarba, D. J. Hansen, W. Berry, R. C. Swartz, C. Cowan, S. Pavlou, H. Allen, N. Thomas and P. Paquin. Technical basis for establishing sediment quality criteria for nonionic organic-chemicals using equilibrium partitioning. *Environ. Toxicol. Chem.* 10, 1541-1583, 1991.
- Fernandez, L.A.; J.K. MacFarlane, A.P. Tcaciuc, and P.M. Gschwend. Measurement of freely dissolved PAH concentrations in sediment beds using passive sampling with low density polyethylene strips. *Environ. Sci. & Technol.*, 43, 1430-1436, 2009a.

Fernandez L.A., C.F. Harvey, and P.M. Gschwend. Using performance reference compounds in polyethylene passive samplers to deduce sediment pore water concentrations for numerous target chemicals. *Environ. Sci. Technol.*, 43, 8888-8894, 2009b.

Follett, E. Investigation of Polyethylene Passive Sampler's Efficacy in Deducing Sediment Pore Water Concentrations of PCBs. MS thesis submitted to the Dept. of Civil and Environ. Eng., MIT, Cambridge, MA. September 2011. 150 pp.

Gschwend, P.M., J.K. MacFarlane, D.D. Reible, X. Lu, S.B. Hawthorne, D.V. Nakles, and T. Thompson. Comparison of polymeric samplers for accurately assessing PCBs in pore waters. *Environ. Toxicol. & Chem.* 30, 1288-1296, 2011.

Gschwend, P.M., J.K. MacFarlane, K. Palaia, S. Reichenbacher, and D. Gouveia. GUIDANCE DOCUMENT Passive PE Sampling in Support of In Situ Remediation of Contaminated Sediments: Standard Operating Procedure for PE Preparation. December 2012a. Available at <https://www.serdp-estcp.org/Program-Areas/Environmental-Restoration/Contaminated-Sediments/ER-200915>

Gschwend, P.M., J.K. MacFarlane, K. Palaia, S. Reichenbacher, and D. Gouveia. GUIDANCE DOCUMENT Passive PE Sampling in Support of In Situ Remediation of Contaminated Sediments: Standard Operating Procedure for PE Deployment. December 2012b. Available at <https://www.serdp-estcp.org/Program-Areas/Environmental-Restoration/Contaminated-Sediments/ER-200915>

Gschwend, P.M., J.K. MacFarlane, K. Palaia, S. Reichenbacher, and D. Gouveia. GUIDANCE DOCUMENT Passive PE Sampling in Support of In Situ Remediation of Contaminated Sediments: Standard Operating Procedure for PE Analysis. December 2012c. Available at <https://www.serdp-estcp.org/Program-Areas/Environmental-Restoration/Contaminated-Sediments/ER-200915>

Gustafsson, Ö., F. Haghseta, C. Chan, J.K. MacFarlane, and P.M. Gschwend. Quantification of the dilute sedimentary soot phase: Implications for PAH speciation and bioavailability. *Environ. Sci. Technol.*, 31, 203-209, 1997.

Hansen, B. G.; Paya-Perez, A. B.; Rahman, M.; Larsen, B. R. QSARs for KOW and KOC of PCB congeners: A critical examination of data, assumptions and statistical approaches. *Chemosphere* 39(13), 2209–2228, 1999.

Hawker D.W. and D.W. Connell. Octanol-water partition coefficients of polychlorinated biphenyl congeners. *Environ. Sci. Technol.* 22: 382-387, 1988.

Hawthorne, S.B., C.B. Grabanski, D.J. Miller, and J.P. Kreitinger. Solid-phase microextraction measurement of parent and alkyl polycyclic aromatic hydrocarbons in milliliter sediment porewater samples and determination of K_{DOC} values. *Environ. Sci. Technol.* 39, 2795-2803, 2005.

Huckins, J. N.; Tubergen, M. W.; Manuweera, G. K. Semipermeable membrane devices containing model lipid: A new approach to monitoring the bioavailability of lipophilic contaminants and estimating their bioconcentration potential. *Chemosphere* 20, 533-552, 1990.

ICF, International. Record of Decision for Sediment-Operable Unit 2. U.S. Army Natick Soldier Systems Center, Natick Massachusetts. Sept 2009. Available at www.epa.gov/region1/superfund/sites/naticklab/457360.pdf.

Koelmans, A. A.; Jonker, M. T.; Cornelissen, G.; Bucheli, T. D. Van Noort, P.; Gustafsson, Ö. Black carbon: The reverse of its dark side. *Chemosphere* 63 (3), 365–377, 2006.

Lohmann, R. R.M. Burgess; M.G. Cantwell; S.A. Ryba; J.K. MacFarlane; and P.M. Gschwend. Dependency of polychlorinated biphenyl and polycyclic aromatic hydrocarbon bioaccumulation in *Mya arenaria* on both water column and sediment bed chemical activities. *Environ. Toxicol. Chem.*, 23, 2551-2562, 2004.

Tcaciuc, A. P.; Apell, J. N.; Gschwend, P. M. July 2014. Performance Reference Compound Calculator for Use in Support of PE Passive Samplers. <https://www.serdp-estcp.org/Program-Areas/Environmental-Restoration/Contaminated-Sediments/ER-200915>.

APPENDICES

Appendix A: Points of Contact

POINT OF CONTACT Name	ORGANIZATION Name Address	Phone Fax E-mail	Role in Project
Philip M. Gschwend	MIT, 48-216G, Cambridge MA, 02139	(t) 617-253-1638 (f) 617-258-8850 pmgschw@mit.edu	Principal Investigator
Kevin J. Palaia	ICF International 100 Cambridgepark Dr. Cambridge, MA 02140	(t) 617-250-4271 (f) 617-250-4261 Kevin.Palaia@icfi.com	Co-Principal Investigator
Andrea Leeson	SERDP & ESTCP 4800 Mark Center Drive Suite 17D08 Alexandria, VA 22350	(t) 571-372-6398 (f) 571-372-6386 Andrea.leeson.civ@mil.mail	Environmental Restoration Program Manager

Appendix B: Standard Operating Procedures

Standard Operating Procedure for the Preparation of Polyethylene (PE) and Polyethylene Devices (PEDs) Used for Passive Sampling

1.0 SCOPE AND APPLICATION

- 1.1 This method describes a procedure for preparing and handling polyethylene (PE) films that will be cut into strips and used in polyethylene devices (PEDs) to passively sample hydrophobic organic compounds (HOCs) in environmental media.
- 1.2 This method generates PE that can be deployed within PEDs for passive sampling of HOCs in atmospheric, aqueous, or sediment-porewater systems.
- 1.3 PE that is prepared by this method is suitable for laboratory or *in situ* field deployment.

2.0 SUMMARY OF METHOD

- 2.1 A known mass of low density polyethylene (LDPE) sheet, usually gram quantities, is cleaned by sequentially extracting with methylene chloride, methanol, and ultrapure water in a closed glass vessel.
- 2.2 Clean PE is equilibrated with performance reference compounds (PRCs) dissolved in water or methanol-water (see Appendix 1 for possible PRCs).
- 2.3 Prepared PE is stored in contaminant-free, sealed, glass vessels.
- 2.4 Shortly before deployment, the PE is cut into strips and either placed in aluminum mesh bags for water sampling water or aluminum frames for sediment sampling. PEDs are transported to the field wrapped in clean aluminum foil.
- 2.5 In the field, the PE is exposed to the environmental medium of concern. HOCs in the medium diffuse into the PE, while PRCs diffuse out.

3.0 INTERFERENCES

- 3.1 PE is susceptible to contamination from atmospheric vapors and contact with surfaces (e.g., worker hands), so it must remain in clean sealed vessels until deployment.

4.0 APPARATUS AND MATERIALS

- 4.1 Extraction vessels: 1-L glass bottles or screw capped jars (foil-lined lids).
- 4.2 Storage vessels: bottles with glass stoppers or amber jars (foil-lined lids).
- 4.3 Bottle/jar tumbler, shaker table, bottle roller, or equivalent.
- 4.4 Low density polyethylene (LDPE): commercial grade, large sheet at 25 μ m (1 mil) or 51 μ m (2 mil) thickness. The thickness is chosen to be strong enough to withstand stresses during deployment (e.g., insertion into sediment), but thin enough to exchange a significant fraction (e.g., >20%) of its PRCs during the deployment time to be used.

- 4.5 Food grade aluminum foil (solvent cleaned and/or combusted to remove any organic residue from foil production)
- 4.6 Stainless steel forceps
- 4.7 Teflon (or similar non-contaminating material) cutting board

5.0 REAGENTS

- 5.1 Methylene chloride, CH₂Cl₂, pesticide grade or equivalent
- 5.2 Methanol, CH₃OH, pesticide grade or equivalent
- 5.3 Organic-free reagent water (as defined in SW-846 Chapter 1)
- 5.4 Research grade PRCs certified >98+% pure.

Note: Specific standard materials, concentrations, solvents, and solvent purity requirements will be determined based upon that target HOCs of concern for the particular application

6.0 PRESERVATION AND HANDLING

- 6.1 Clean PE should be stored in clean sealed glass vessels.
- 6.2 Until deployment, prepared PE (PE loaded with PRCs) is stored in sealed glass containers with a few mL of organic-free reagent water added to maintain 100% relative humidity within the storage vessels (minimizing sorptive losses of PRCs to glass vessel walls).
- 6.3 Laboratory and field personnel should wear nitrile or latex gloves whenever handling clean PE.
- 6.4 Methylene chloride-rinsed, stainless steel forceps and scissors are used when manipulation of clean PE is required.
- 6.5 Methylene chloride-rinsed, aluminum foil is used to cover any surface that clean PE may encounter.

7.0 PROCEDURE

- 7.1 Polyethylene Cleaning Procedure: LDPE is purchased from hardware/painting stores in large sheets ('dropcloth or plastic tarp' material) with thickness of 25µm (1 mil) or 51µm (2 mil), depending on the user's need for strength (choose thicker) and desire to use short deployment times (used thinner). The sheet is cut into strips sized for environment and frames to be used. An organic solvent cleaning sequence is then used to prepare the PE. This process ensures that extractable oligomers, plasticizers, and contaminating organic chemicals are removed from the PE prior to use. All extractions are performed sequentially in the same container.
 - 7.1.1 Methylene chloride is placed into the extraction vessel, and the PE strips are immersed in the container for 24 hours to enable time for diffusive transfers out of the PE. The initial methylene chloride extract is discarded and a second methylene chloride extraction is performed for 24 hours. The second methylene chloride

extract is discarded and replaced by methanol in order to remove methylene chloride from the PE. Methanol immersion is also done for 24 hours. The initial methanol extract is discarded and followed by a second methanol soak for 24 hours. Finally, the second methanol extract is discarded and the PE undergoes three 24-hour soaks with organic-free reagent water (within the same extraction vessel) to remove residual methanol from the PE.

- 7.1.2 The cleaned PE is stored in organic-free reagent water in the extraction vessel until further processing.
- 7.2 Polyethylene Preparation with Performance Recovery Compounds (PRCs): PRCs are loaded into the clean PE, prior to its field deployment, by utilizing either aqueous (Fernandez et al. 2009) or 80:20 methanol:water equilibrations (Booij et al., 2002). Depending on the hydrophobic organic compounds of interest, PRCs should be chosen which mimic mass transfer phenomena governing exchanges during field deployments. It is important to avoid adding PRCs that the analytical laboratory already uses as surrogate or injection standards. PRC loading is performed by placed the PE in pre-cleaned glass vessels containing known PRC solutions made up in organic-free reagent water with or without pesticide-grade methanol. The PE user should estimate the expected accumulation of target compounds in the passive sampler and seek to load with similar levels of PRCs to facilitate the eventual chemical analyses. Sufficient PRC equilibration time during this PE preparation step is necessary to ensure uniform PE loading across the entire PE thickness; hence thicker PE sheet is more robust for field use, but takes longer to load with PRCs.
- 7.2.1 Isotopically labeled compounds are useful internal standards when Gas Chromatography-Mass Spectrometry (GCMS) is the method of separation and detection. For example, deuterated polycyclic aromatic hydrocarbons (PAHs) and C13-labeled PCBs are effective methodological standards for PE passive sampling. One subset of compounds, distributed across the range of PAHs to be assessed (e.g., d10-phenanthrene, d10-pyrene, and d12-chrysene), should be used as PRCs, while another set (e.g., d10-anthracene, d10-fluoranthene, and d12-benz(a)anthracene) is used as surrogate (recovery) compounds during later analysis of field-deployed PE. Finally, compounds such as d10-acenaphthene, d14-*m*-terphenyl, and d12-perylene can be used as injection standards. Similar sets of labeled compounds should be used for other compound classes (see Appendix 1). Note: if PE samples are eventually to be analyzed at a contract laboratory, PRC choices must be made so as not to conflict with recovery and injection standards used by that laboratory.
- 7.2.2 As subsequent analysis (e.g., GCMS) is best achieved with both PRCs and target HOCs present at like concentrations in the PE extracts, the optimal concentration level of the PRC loaded into the PE is dependent on the environment in which the PE is to be deployed. For example, if a target HOC is expected to occur in the water or pore water near 1 ng/L levels, one can use that compound's LDPE-water partition coefficient (e.g., Fernandez et al., 2009; Lohmann, 2012) to estimate the expected levels in the PE after deployment:

$$\text{Concentration in PE (ng/kg)} \sim K_{LDPE\text{-}water} * \text{concentration in (pore)water (ng/L)}$$

So if the $K_{PE-water}$ for the target HOC of interest is 10^5 (L/kg), then the concentration of the target HOC in the PE will approach 100 ug/kg. Based on this estimate, the PRCs are loaded into the PE at similar concentrations.

- 7.2.3 **Aqueous PRC Loading:** A solvent-cleaned and dried glass container is filled with ultrapure water that has been spiked with known concentrations of PRCs (e.g., using calculations like those shown in Appendix 2). A known mass of pre-cleaned PE is then added and weighted to insure complete PE submersion. The vessel is agitated to remove any air pockets adhering to the submerged PE. Equilibration times vary for different PRC/PE thickness combinations and the PE-water phase ratio. For PAHs and PCBs, use at least 30 days to insure homogeneous distributions of the PRCs throughout the entire thickness of the PE film unless faster equilibration has been confirmed. Confirmation can be done by time course measures of PRC concentrations in the PE or by showing that concentrations of PRCs are the same for films of different thicknesses, but the same masses. Generally, PE is stored in the PRC solution until it is to be deployed.
- 7.2.4 **Methanol-Aided PRC Loading:** A solvent-cleaned and dried glass container is filled with an 80:20 mixture of pesticide grade methanol and ultrapure water that has been spiked with known concentrations of PRCs (e.g., see calculations in Appendix 2). A known mass of pre-cleaned PE is then added and weighted to insure complete submersion. The vessel should be agitated to remove any air pockets adhering to the submerged PE. Equilibration times vary for different PRC/PE thickness combinations and the PE-solvent phase ratio, but typically this step is completed within 7 days since methanol swells the PE and thereby speeds PRC diffusion into the polymer sheet (Booij et al., 2002). Generally, the PE is stored in the PRC solution until shortly before it is to be deployed. Before deployment, the PRC-loaded PE is rinsed with ultrapure water, and then it is soaked in ultrapure water for 24 h to remove methanol from the PE. This methanol leaching step is repeated twice to insure complete methanol removal.

7.3 PED Assembly

- 7.3.1 PEDs can be pre-assembled with prepared PE strips up to a few days prior to deployment depending on the target compounds of interest.
- 7.3.2 *For Water Sampling with PE in a Stainless Steel Mesh Bag.* Since PE that is openly exposed in the water column has been observed to be eaten by aquatic organisms, the PE must be protected by deploying it in a mesh bag.
- 7.3.2.1 Cut rectangles from the mesh that are larger than the piece of PE to be deployed. Clean the mesh with methylene chloride, methanol, and water.
- 7.3.2.2 Wearing nitrile gloves, and using solvent-rinsed stainless steel forceps, lay a piece of the mesh on a clean surface such as an aluminum-foil covered lab bench. Remove the PE strip from its container and lay it on top of a stainless steel mesh. Place the second mesh on top. The two meshes are sealed together by folding the

edges over on one another, and then sewing them together with nylon fishing line. Grommets can be added to the upper corners to facilitate mesh labeling and attachments in the field.

7.3.3 *For Sediment Bed Sampling with PE in an Aluminum Sheet Metal Frame.* In order to insert the PE strips into a sediment bed, the PE must be carried by an aluminum frame (Figure 1).

7.3.3.1. Aluminum sheet metal is cut into two complementary pieces that can be bolted together such that a piece of PE sheet is held in place. After cutting, these pieces of aluminum must be washed with organic solvents (e.g., methylene chloride and methanol) and then rinsed with water.

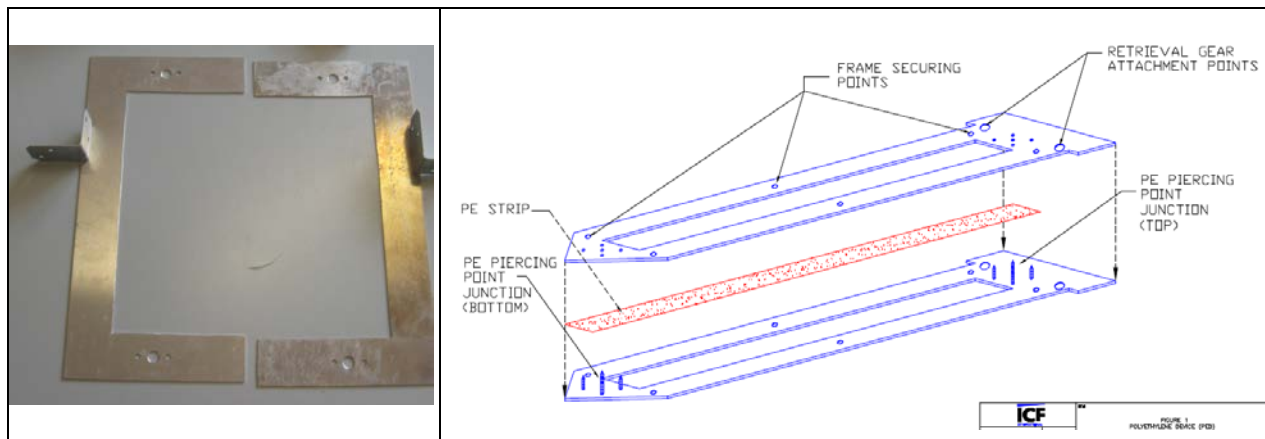

Figure 1.

(left panel) Aluminum sheet cut into two "C-shaped" pieces allowing the investigator to mount and hold ~25 cm strips of PE an open window when the two pieces are overlapped and bolted together.

(right panel) Drawing of two aluminum sheet pieces cut so as to sandwich a strip of PE and expose about 50 cm of length.

7.3.3.2 Wearing nitrile gloves, lay a piece of the aluminum frame containing the PE piercing points (sheet metal screws, see Figure 1), sharp side up, on a sheet of solvent-rinsed aluminum foil.

7.3.3.3 Using solvent-rinsed stainless steel forceps, remove the PE strip from its container and lay the strip lengthwise across both sets of PE piercing point junctions. PE strips should have been sized to fit the frame with a little extra length, allowing the investigator to cut a small strip of PE from one end to serve as sample for PRC concentration measures before the sampler is deployed. At one end of the PED frame, gently push the remainder of the PE strip onto the PE piercing points so all points penetrate the PE strip. Gently pull the other end of the PE strip over the adjacent PE piercing points, keeping the PE strip taut, and push that end of the PE strip into the PE piercing points. The tautness of the PE strip should have as minimal deflection as possible between the two PE piercing point junctions, but not too tight so that movement of the PE causes it to rip or tear. Place the other PED frame over

the PED frame containing the PE strip so that each of the PE piercing point junctions meet and both PED frames are flush against each other. Secure the two frames together using the appropriate hardware (stainless steel machine screws, locking washers, and cap nuts).

7.3.3.4 Wrap the entire PED frame in solvent-rinsed aluminum foil to prevent exposure during transport and field preparation activities.

7.4 PE and PED Storage and Shipment:

7.4.1 Prepared PEDs in their foil envelopes may be stored a few days at ambient temperature prior to deployment. Freezing or excessive heat should be avoided to minimize the likelihood of changing the polymer crystallinity. It is recommended that PEDs be hand carried or shipped in a timely fashion (Overnight or Next Day if possible) to minimize chances sampler contamination or damage.

7.4.2 If PE is to be shipped to another location for PED assembly, it is recommended that the PE strips are individually sealed in pre-cleaned glass vials that contain a little water. Freeze shipping should be avoided, but cold (refrigeration temperature) packing may be necessary depending on time of season and individual laboratory handling/quality control procedures.

8.0 QUALITY CONTROL

8.1 PRC Loading Validation: At least six representative samples of prepared PE should be collected (e.g., 6 x 10 mg pieces), extracted, and analyzed prior to field deployment to validate that the PRC concentrations are consistent with their intended loadings and these standards have uniform concentrations in a batch of PE.

8.2 Target HOC Blanks: Subsamples of prepared PE, commensurate in size with the planned environmental PE samples (e.g., 10 cm wide by 5 cm long by 25 um thick and therefore weighing about 120 mg), should be collected, extracted, and analyzed prior to field deployment to demonstrate that other substances have not contaminated the PE which would contribute to interfering background for the target HOCs.

9.0 METHOD PERFORMANCE

9.1 PRC data, obtained from PE samples collected from >six parts of the prepared PE, should be consistent within about 10% (i.e., 100 x standard deviation / mean).

9.2 Target HOC concentrations should be undetectable in the prepared PE (e.g., < 1 ng/g PE assuming 100 mg PE subsamples).

10.0 REFERENCES

Adams, R.G., Lohmann, R., Fernandez L.A., MacFarlane, J.K., and Gschwend, P.M., Environ. Sci. & Technol. 2007, 41, 1317-1323.

Booij, K, Smedes, F., van Weerlee, E.M., Chemosphere 2002, 46, 1157-1161.

Fernandez, LA, MacFarlane, J.K., Tcaciuc, A.P., and Gschwend, P.M., Environ. Sci. & Technol; 2009, 43, 1430-1436.

Hawker DW and Connell DW. 1988. Environ. Sci. Technol. 22: 382-387.

Lohmann, R. MacFarlane, J.K. and Gschwend, P.M., Environ. Sci. & Technol; 2005, 39, 141-148.

Lohmann, R. Environ. Sci. & Technol.; 2012, 46, 606–618.

Appendix 1 Suggested Performance Reference Compounds (PRCs), Surrogate Compounds (Recovery Standards), and Injection Standards.

A. PRCs, suitable for polycyclic aromatic hydrocarbon (PAH) determinations when Gas Chromatography-Mass Spectrometry (GCMS) is the preferred method of detection, include, but are not restricted to, deuterated PAH compounds. One subset should be used as PRCs, while reserving others for use as surrogate (recovery) compounds. Still other compounds such as terphenyl can be used as injection standards.

Targets: PAHs	Method: GCMS			Detection Limit ~ 100 pg / 100 mg PE		
PRCs	d10-phenanthrene	d10-pyrene	d12-chrysene			
Surrogates	d10-anthracene	d10-fluoranthene	d12-benz(a)anthracene			
Injection Standards	d10-acenaphthene	d14- <i>m</i> -terphenyl	d12-perylene			

B. PRCs and surrogate compounds suitable for polychlorinated biphenyl (PCB) determinations when GCMS is the preferred method of detection include, but are not restricted to, ¹³C-labeled or deuterated PCB congeners. One subset, for example including a tri-, tetra-, penta-, hexa-, and heptachloro-biphenyl, can be used as PRCs while reserving different tri-, tetra-, penta-, hexa-, and heptachloro-biphenyl congeners to serve as surrogate compounds. Still other compounds such as deuterated PAHs or rare PCBs (not contained in Aroclor/Clophan mixtures such as: PCB-39, PCB-55, PCB-104, PCB-150 and PCB-188) can be used as injection standards.

Targets: PCBs	Method: GCMS						Detection Limit ~ 100 pg / 100 mg PE					
PRCs	¹³ C PCB-28	¹³ C PCB-52	¹³ C PCB-101	¹³ C PCB-153	¹³ C PCB-180							
Surrogates	¹³ C PCB-19	d ₆ PCB-77	¹³ C PCB-105	¹³ C PCB-167	¹³ C PCB-170	¹³ C PCB-194						
Injection Standards	d17-39	d22-104	d34-55	d40-150	d52-188							

C. When analyzing for organochlorine pesticides such as DDT using GCMS, ¹³C labeled compounds can serve as PRCs and surrogate standards. Since DDT has been seen to degrade to form DDE or DDD in certain situations, one should use the 4,4'- isomer of DDT and the 2,4'-isomers of DDE and DDD as PRCs to allow appearance of ¹³C-labelled 4,4'-DDE of 4,4'-DDD to be interpreted as arising from reaction of the DDT PRC during

the deployment. Deuterated or ^{13}C labeled PCBs can be used as surrogate (recovery) and injection standards.

Targets: DDTs	Method: GCMS	Detection Limit ~ 200 pg / 100 mg PE	
PRCs	^{13}C 2,4'-DDE	^{13}C 2,4'-DDD	^{13}C 4,4'-DDT
Surrogates	^{13}C -PCB111	^{13}C -PCB153	^{13}C 2,4'-DDT
Injection Standards	d6 PCB 77	^{13}C PCB 105	^{13}C PCB 167

Standard Operating Procedure

Deployment and Retrieval of Polyethylene Devices (PEDs) in Sediment

1.0 Scope and Objective

The purpose of this Standard Operating Procedure (SOP) is to provide a description of the methods used in the deployment and retrieval of polyethylene devices (PEDs) in sediment-pore water environments for the sampling of hydrophobic organic compounds (HOCs) such as polycyclic aromatic hydrocarbons (PAHs) and polychlorinated biphenyls (PCBs). The overall objective of PED sampling is to determine the horizontal and vertical distributions of HOCs in pore waters of bed sediments. This SOP does not discuss deployment of PEDs in atmospheric or aqueous systems. This SOP should be used in conjunction with companion SOPs for *Preparation of Polyethylene (PE) Media* and *Extraction Procedures for PE Media*.

The installation and retrieval methodologies discussed in this SOP are general in nature and may be modified to meet the handling or analytical requirements of the contaminants of concern, as well as constraints presented by site conditions or equipment limitations. If modifications are made, they should be appropriately documented in site planning documents (e.g., Work Plan, Sampling and Analysis Plan, Quality Assurance Project Plan [QAPP]), a field logbook, and in reports summarizing field activities and analytical results.

The methodologies in this SOP are applicable to PED sampling of sediments situated under static aqueous layers (i.e., lakes, ponds, wetlands, or impoundments) and flowing waters (i.e., rivers, streams) which may be of a marine, brackish, or a fresh water nature, at water depths generally less than 100 feet. The degree of difficulty of PED deployment and retrieval increases as water depths, currents, and wind speeds increase. For the purpose of this procedure, sediments are those mineral and organic materials situated beneath an aqueous layer. PEDs assembled, installed, and retrieved following these procedures will be suitable for laboratory measurements.

2.0 Summary of Methods

Field personnel should wear nitrile gloves while performing the procedures described in this SOP so as to avoid transferring contaminating HOCs to the PEDs. Potential hazards associated with the planned tasks should be evaluated prior to conducting field activities. A site-specific Health and Safety Plan (HASP) should provide a description of potential hazards and associated safety and control measures.

PEDs are typically constructed from (a) polyethylene sheet prepared as described in the companion SOP, *Preparation of Polyethylene (PE) Media*, and (b) aluminum sheet metal (Figure 1). PEDs are assembled by mounting the laboratory-provided PE strip within a decontaminated aluminum PED frame. Generally, the machine screws used to hold the two pieces of aluminum sheet together are also used to pierce the PE sheet and hold it stretched across the open window. Pointed aluminum sheet can be used to assist in subsequent field insertions into cohesive sediment beds. It is also useful to use a dremel tool to inscribe the aluminum frame with an identifying label.

After the PE is placed in the Al frame, the entire assembly is carefully wrapped completely in solvent-cleaned (e.g., dichloromethane), heavy-duty, aluminum foil. The wrapped samplers are

also labeled on the outside for field crew identification, and then they are carefully arrayed in a clean shipping container (e.g., a cooler).

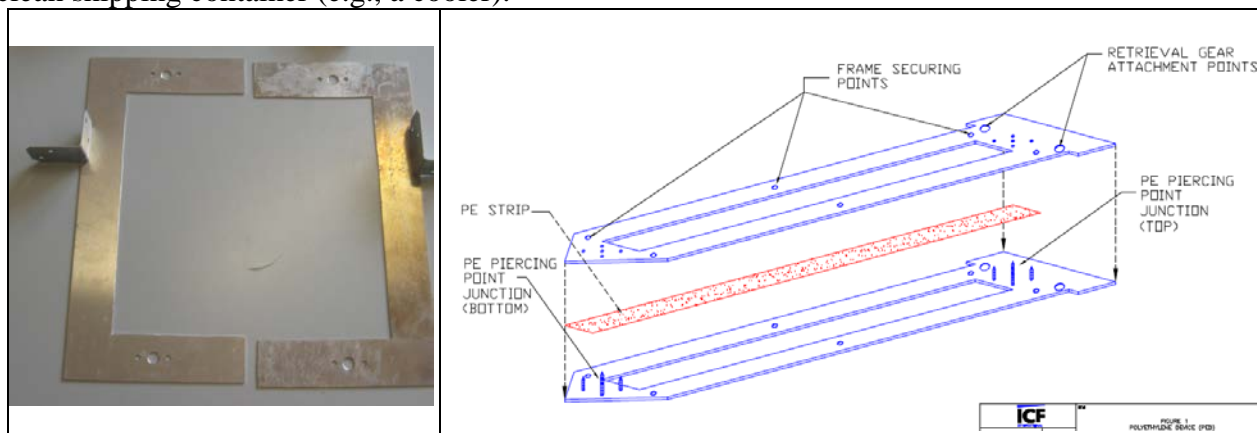

Figure 1.
(left panel) Aluminum sheet cut into two "C-shaped" pieces allowing one to mount and hold ~25 cm strips of PE an open window when the two pieces are overlapped and bolted together.
(right panel) Drawing of two aluminum sheet pieces cut so as to sandwich a strip of PE and expose about 50 cm of length.

For deployment, additional equipment and lines can be used. For example, for PED insertion into relatively shallow sediments (<15 feet) from a boat, the PED frame can be inserted and locked into a Toggle-Locking Device (TLD), a device specifically designed for PED installations (Figure 2 left panel). This fitting can be connected to an adjustable extension painter's pole. The PED is then lowered into the water and down to the top of the sediment bed. The PED is pushed into the sediment so that the PE strip within the PED is positioned across the sediment-surface water interface. The PED is then unlocked from the TLD and left in place. For deployments in moderate depth waters (<60 feet), divers can be used to insert the PEDs in the bed sediment. Finally, at still deeper locations, PEDs can be affixed to a platform and lowered from a vessel to the bottom where the weighted vehicle causes the PEDs to be inserted in the bed (Figure 2, right panel). In all cases, recovery lines are attached to the PEDs via carabiners, and these lines may be tied to nearby pilings or marker buoys to locate the samplers for future recovery.

PEDs are typically left in place for a period of weeks to months, depending on the HOCs of interest. These deployment times are usually too short to achieve sediment-PE equilibration of the HOCs, so it is necessary to measure the losses of the performance reference compounds (PRCs) in order to be able to correct target HOC concentrations to their equilibrated levels (Fernandez et al., 2009). During the deployment, the target HOCs diffuse into the PE from the surrounding sediments, while the performance reference compounds (PRCs) are simultaneously diffusing outwards.

Once retrieved, the PEDs are transported to a clean laboratory. Here, the surfaces of the PE strip are wiped clean, the PE is cut into appropriate section lengths, and the cut pieces are transferred to clean glass vials for shipping to a laboratory for analysis.

3.0 PED Sample Preservation, Handling, and Storage

The following procedures should be followed during preservation, handling, and storage of PE and PEDs.

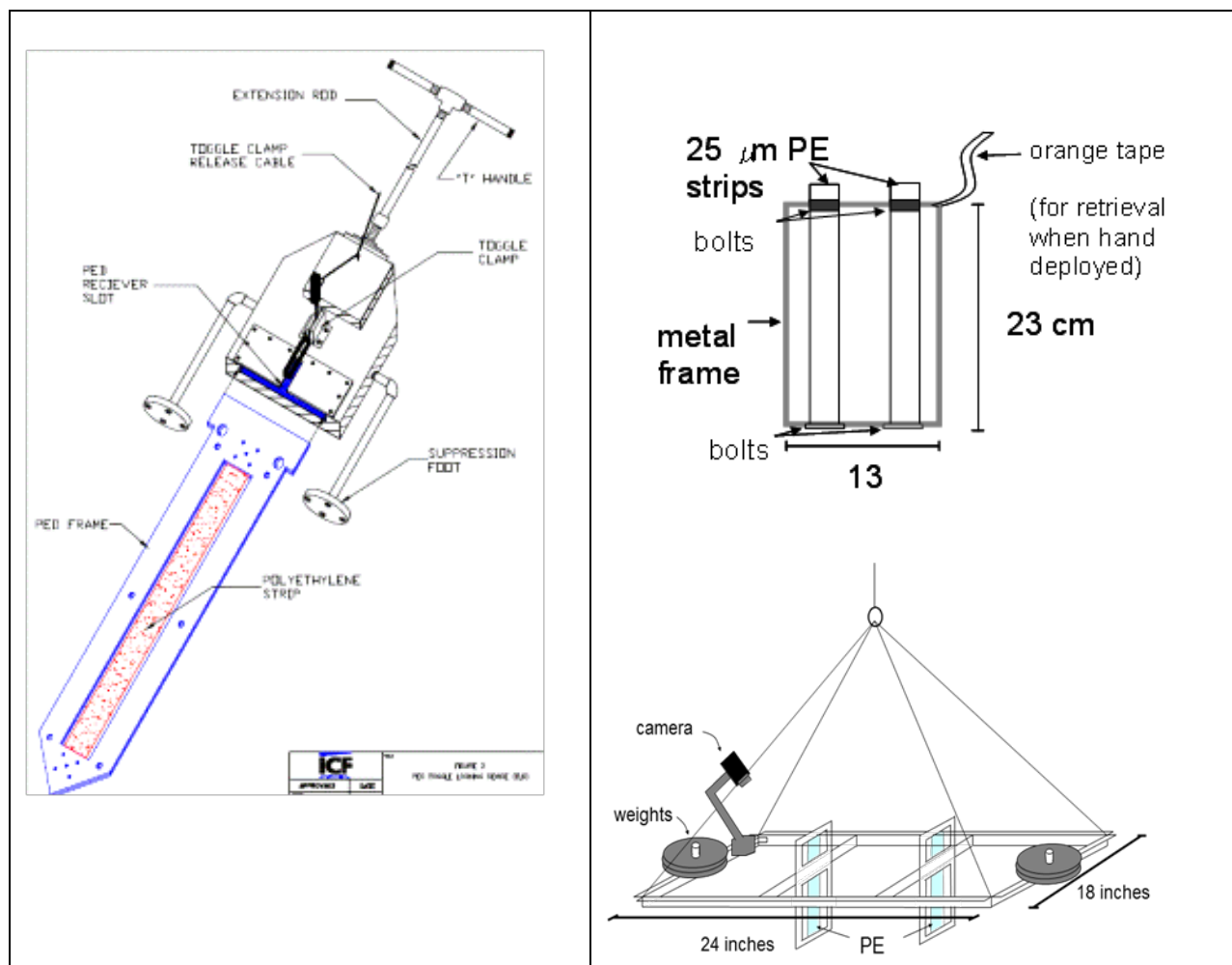

Figure 2. Illustrations of polyethylene strips mounted in aluminum sheet metal frames for field deployments into sediment beds. The left panel shows a larger sampler (~50 cm vertical opening) which can be inserted into the sediment beds using a releasable extension rod that can reach about 5 m deep while standing on a boat. The suppression feet insure positioning of the sampler at a known depth across the sediment-water interface. A line is attached to the toggle clamp to release the sampler from the deployment hardware after insertion into the sediment bed. The right panel shows a shorter sampler (vertical opening ~20 cm) suited to hand deployment in shallow/tidal locations or for mounting on a weighted frame that can be lowered from a vessel in deeper water. Both the short and long samplers can be deployed in intermediate water depths by divers.

- If PE strips are provided by the contracted laboratory, the PE will have been cleaned and equilibrated with performance reference compounds (PRCs); the PE strips will be

shipped in sealed glass containers; and they will be ready for installation into the PED frame.

- In some cases, the assembled PEDs may be shipped from the laboratory with the PE strip already installed.
- The PE strips are susceptible to contamination from atmospheric vapors and contact with surfaces (i.e., worker hands). Nitrile gloves should be worn at all times when handling the PE strips and PED frames.
- PED aluminum frames and hardware should be decontaminated prior to PE strip installation following standard EPA decontamination procedures (i.e., EPA SOP #2006) or site-specific Work Plan or QAPP procedures.
- Transfer of the PE strip to and from the PED frame should be done with solvent-rinsed stainless steel forceps. Organic solvent-rinsed aluminum foil (solvent chosen to clean foil of any HOCs in target set) should be used to cover any surface that clean PE or PEDs may encounter.
- Loaded PEDs should also be wrapped in solvent-rinsed aluminum foil both prior to and after recovery to prevent sampler exposures that might contribute background HOCs.
- Before shipping retrieved PE strips, it is recommended that each PE strip be wiped clean on both sides, cut into appropriate sections, and individual sections sealed in a pre-cleaned glass vial that contains a milliliter of distilled water. Solvent should not be added to the PE sections prior to shipment as leakage of solvent during shipping is a health hazard, risks undefined losses of HOCs from the sample, and can obliterate sample labels. Freeze shipping should also be avoided (do not want to change PE crystallinity); but cold packing may be necessary depending on the time of season and individual laboratory handling/quality control (QC) procedures.

4.0 Equipment

Equipment needed for PED preparation, assembly, deployment in relatively shallow waters (<15 feet), and retrieval may include:

- Boat
- Chain-of-custody forms
- Communication equipment (cell phone or radio)
- Coolers
- Extension rods, painter's pole.
- Global Positioning System (GPS) device
- Hand tools
- Logbook
- Maps/Sampling and Analysis Plan/field sampling forms
- Personal protective equipment (PPE) and safety equipment

- Nitrile gloves
- PE sample containers
- Pre-assembled PEDs
- Preprinted sample labels
- Sink rope
- Solvent-rinsed aluminum foil
- Sounding rod, fathometer, or weighted tape measure
- Spring links or carabiners
- Surface marker buoys
- “T” Handle
- Toggle Locking Device (TLD)

5.0 Procedures

The following sections describe the general methods and procedures for preparing, assembling, deploying, and retrieving PEDs from a sediment bed. These procedures can be used in both a flowing or non-flowing water body; however equipment requirements will depend on water depth and velocity.

5.1 Preparation

- Determine a sampling strategy, including identifying the objective(s), extent of the sampling effort, and specific sampling locations, in accordance with site-specific planning documents.
- Perform a general site survey to determine the conditions of the sampling area including water depths, water currents, and sediment bed material type (i.e., impediments such as cobble and exposed bedrock that may affect ease of being able to insert PEDs).
- Coordinate staff, client, abutters and regulatory agency involvement, as necessary.
- If not already performed by laboratory supplying PE, decontaminate PED frames and hardware following standard decontamination procedures. Assemble PED frames with laboratory-provided PE strips prior to deployment.
- Obtain necessary sampling and safety equipment.
- Obtain site access agreements and/or permits, as necessary.
- As necessary, pre-mark sampling locations with marker buoys using pre-determined geographic coordinates entered into a GPS device.

5.2 PED Assembly

PEDs can be pre-assembled with prepared PE strips a few days prior to deployment. It is recommended that assembled PEDs not be stored for more than 2 days. At least one PED should be used as a trip blank to ascertain substantial sampler changes during the deployment effort (e.g., accumulation of unexpected background contamination, significant depletion of PRCs).

The following procedures should be followed when assembling the PEDs with a laboratory-provided PE strip:

- Don appropriate PPE, as required by the site-specific HASP.
- On a steady surface, lay the PED frame containing the PE piercing points (see Figure 1), sharp side up, on a sheet of clean aluminum foil.
- Wearing nitrile gloves and using a solvent-rinsed stainless steel forceps, remove the laboratory-provided PE strip from its container and lay the PE strip lengthwise across both sets of PE piercing point junctions. PE strips should be delivered from the laboratory at a pre-determined specified length, depending on the length of your PED and project objectives.
- At one end of the PED frame, gently push the PE strip onto the PE piercing points so all points penetrate the PE strip.
- Gently pull the other end of the PE strip over the adjacent PE piercing points, keeping the PE strip taut, and push that end of the PE strip into the PE piercing points. The tautness of the PE strip should have as minimal deflection as possible between the two PE piercing point junctions, but not too tight so that movement of the PE causes it to rip or tear.
- Place the other part of the PED frame over the portion of the PED frame containing the PE strip so that each of the PE piercing point junctions meet and both PED frames are flush against each other.
- Secure the two frames together using the appropriate hardware (stainless steel machine screws, locking washers, and cap nuts).
- Wrap the entire PED frame in clean aluminum foil to prevent exposure during transport and field preparation activities.

5.3 PED Deployment

PEDs can be installed from a boat platform or by wading into shallow water bodies or streams. In a stream or flowing water setting, always stand downstream of the sampling location; it is also recommended that samplers be aligned to present a minimal cross section to the flow direction so as to minimize bed scouring. Sample locations can be pre-marked or located using a handheld GPS device. Prior to deployment, consider the possible retrieval methods, which may include stringing several PEDs together using sink rope or individually using single surface marker buoys, as described further in Section 5.4 (PED Retrieval). The following procedures detail PED deployment using a TLD:

- Don appropriate PPE, as required by the site-specific HASP.
- Locate the sediment sample location and record the water column depth using a sounding rod, fathometer, or weighted tape measure.
- Based on the water depth, attach the appropriate length of extension rods to the TLD along with the “T” handle (see Figure 2).
- Make sure the retrieval gear attached to the PED frame is functioning properly.
- Remove the loaded PED frame from its aluminum foil wrap and attached the retrieval gear (i.e., spring link or carabiner clips) to the retrieval gear attachment points along the top end of the PED frame (see Figure 1). Insert the top end of the PED frame, together

with the attached retrieval gear, into the receiver slot of the TLD and secure the PED with the toggle clamp (Figure 2). Make sure the PED frame and toggle clamp are fixed firmly.

- The TLD should include a set of suppression feet which are used to prevent over-penetration of the PED into the sediment bed (Figure 2). If needed, the lengths of the suppression feet should be adjustable to provide accurate control of the penetration depth of the PED and to accommodate for various site conditions and project objectives. Extension rods can also be graduated in feet or inches to assist the sampler in knowing how far the PED has penetrated into the sediment bed. Avoid penetrating the PED too deep into the sediment bed. Pushing the entire PE strip below the sediment-surface water interface may cause later retrieval to be difficult, will complicate the determination of the exact location of the sediment-surface water interface, and will prevent data acquisition needed to characterize bed-to-water column concentration gradients.
- Carefully lower the TLD and PED into the water column, over the sampling location, to the top of the sediment bed. Using the “T” handle, push the PED vertically straight down into the sediment bed until you feel the resistance of the suppression feet against the sediment surface or until the desired depth is achieved. Keep the extension rods as vertical as possible when forcing the PED into the sediment to ensure the PED is installed straight (e.g., at a right angle to the sediment bed surface).
- Use the “T” handle, push directly down on the PED. Avoid rocking the “T” handle back and forth as this could damage the PE strip. If necessary, a hammer can be used on the “T” handle to help drive the PED into dense sediment substrates.
- Once the PED is installed at the appropriate depth within the sediment, release the toggle clamp on the TLD by pulling on the toggle clamp cable (Figure 2). This will release the PED frame from the TLD.
- If possible, try to work when the winds and water currents are calm, particularly if the water body is deep. Anchoring may be necessary to stabilize the boat and to ensure the PED is deployed at the planned sampling location.
- If for some reason the PED slips out of the TLD and needs to be re-installed, simply retrieve it using the retrieval gear and re-install following the procedures above. Make sure the PE strip is intact and note the sampler's re-use in the field logbook.
- Complete any required field sampling forms/documentation and move to next location.

5.4 PED Retrieval

The most important element to remember when retrieving the PEDs is maintaining the integrity of the PE strip once it is retrieved. PED retrieval methods vary and should be developed based on site-specific conditions. Regardless of the method, once the PED is retrieved and brought to the surface, the entire PED should be immediately wrapped in clean aluminum foil to protect the PE strip. After all the PEDs are collected, they can be transported to a more controlled environment (e.g., onshore) for processing. There, the PE strip is cleaned of coatings; it is photographed; the strip is cut into sections according to the sampling design (e.g., 5 cm lengths); each section is placed in a glass container that is labeled; and the samples are shipped to the analytical laboratory. If processing on the same day a PED is retrieved is not possible (although that is

preferable), the entire PED frame may be labeled, wrapped in clean aluminum foil, and shipped to the laboratory where the laboratory would remove the PE strip from the PED.

This SOP discusses three common methods for retrieval of PEDs. Regardless of the retrieval method used, it is always a good idea to let the appropriate regulatory agencies and/or local authorities know that marker buoys may be installed in the water body.

5.4.1 Single Floating Marker Buoy

Individual PEDs can be attached to a single marker buoy by rope line or cable. It is suggested that a weighted sink line be used at all times for the rope line instead of nylon rope, which will tend to float on the water surface. Make sure there is sufficient slack in the line to account for wave action and water level fluctuation (e.g., tidal rise), and make sure the marker buoy line is securely fastened to the PED at the retrieval gear attachment points (see Figure 1). In some instances, it may be necessary to label the marker buoy with information relaying what the buoy is for, instructions to not disturb the buoy, and/or possible contact information.

Retrieval involves simply pulling vertically on the rope line or cable from a boat platform to dislodge the PED from the sediment and pulling the PED to the surface. In some instances a winch may be used.

5.4.2 Single Sub-Surface Marker Buoy

Sub-surface marker buoys are installed following the same techniques as floating marker buoys (Section 5.4.1) except the marker buoy is submerged a few feet below the water surface. The main purpose of this technique is to prevent curious onlookers from disturbing the PEDs. In order to set the marker buoys below the water surface, the water depth at the time of deployment should be determined as well as the possible magnitude of water level fluctuation over the deployment period. Using this information, attach the marker buoy to the rope line so the buoy will be submerged a few feet below the water surface when the PED is installed. Make sure there is a sufficient length of slack line attached to the buoy because this will be used to retrieve the PED. In order to retrieve the PED, locate the submerged marker buoy, lower a gaff or large treble hook to retrieve the slack line, and pull the PED from the sediment in the same manner as described for floating marker buoys (Section 5.4.1).

5.4.3 Multiple PED Lines

This technique mimics how lobstermen set their traps and allows for numerous PEDs to be installed with a single marker buoy or in some cases no marker buoy at all. Using weighted sink rope, attach one end to an anchored floating buoy or tie it off to a secure object along the shoreline. Then proceed to the PED sample location on the water, letting out sink rope as you travel. Once the sample location is reached, tie a simple lineman's loop in the sink rope and attach it to the PED retrieval gear. The retrieval gear is then attached to the PED frame through the retrieval gear attachment points (see Figure 1). Install the PED following the PED deployment procedures described in Section 5.3. Once the PED is installed, continue on to the next sample location, letting out more sink rope as you travel. Once the second sample location is reached, repeat the above procedure and move on to the next sample location. This process allows for numerous PEDs to be installed across a lengthy distance, in a linear or non-linear mode, and without raising the curiosity of onlookers by using numerous floating marker buoys. If needed, marker buoys can be installed midway and/or at the end of the line.

In order to retrieve the PEDs, simply grab hold of the end of the sink rope and coil it up as you move to the first sample location. Once the sample location is reached, pull on the sink rope and retrieve the PED. Detach the retrieval gear from the linesman loop and wrap the entire PED in clean aluminum foil, and move on to the next location and repeat. In the event one of the PEDs cannot be retrieved, the sink rope which continues to the next PED must be retrieved.

6.0 Quality Assurance/Quality Control

There are no specific quality assurance (QA) activities which apply to the implementation of these procedures. However, the following QA procedures are suggested:

- All data must be documented in field sampling forms or within site logbooks.
- All PE strip handling procedures must be followed in accordance with laboratory specifications and/or site-specific planning documents.
- Standard chain-of-custody procedures should be followed when handling and transporting PE samples from the site to the laboratory.
- All field QC sample requirements in the site-specific QAPP should be followed. This may include trip blanks and field duplicate samples to monitor interferences and cross contamination.

7.0 Health and Safety

When working with potentially contaminated materials (i.e., contaminated sediment), health and safety procedures should be followed as specified in a site-specific HASP. More specifically, when working on or near water bodies, physical hazards must be identified and adequate precautions must be taken to ensure the safety of the sampling team. This should include, at a minimum, wearing adequate protective equipment, flotation devices, and making use of lifelines.

8.0 References

Massachusetts Institute of Technology (MIT). Standard Operating Procedure: Extraction Procedures for PE Media.

Massachusetts Institute of Technology (MIT). Standard Operating Procedure: Preparation of Polyethylene (PE) Media.

U.S. EPA. Environmental Response Team (ERT). Sediment Sampling, SOP No. 2016, Revision 0.0. November 17, 1994.

U.S. EPA Region 1. Soil, Sediment, and Solid Waste Sampling, Revision 2. February 13, 2004.

U.S. EPA Region 9. Sediment Sampling, SOP No. 1215, Revision 1. September 1999.

U.S. EPA. Sampling Equipment Decontamination, SOP No. 2006, Revision 0.0. August 11, 1994.

Standard Operating Procedure for the Extraction and Analysis of Polyethylene (PE) Used in Polyethylene Devices (PEDs)

1.0 SCOPE AND APPLICATION

- 1.1 This method describes procedures for chemical analysis of contaminants contained in polyethylene (PE) that has been deployed in polyethylene devices (PEDs) to sample hydrophobic organic compounds (HOCs) in aquatic and sediment environments.
- 1.2 This procedure generates extracts suitable for High Resolution Gas Chromatography/Mass Spectrometry (GCMS) analysis.
- 1.3 This extraction procedure is applicable to PE used in laboratory- or field-exposed PEDs.

2.0 SUMMARY OF METHOD

- 2.1 Upon recovery from the field exposure, the PE, while still in the PED, should be carefully cleaned (e.g. remove adhering sediment) and then cut into appropriate lengths (e.g., to obtain replicates or to acquire sections exposed to varying depths into a sediment bed). The PE pieces, usually 10 to 100 milligram quantities, are placed in pre-cleaned, amber, glass vials with a drop of water for shipping. Once received by the analytical laboratory, each sample is spiked with Surrogate standards (to assess analyte recoveries) and submerged in a suitable solvent (e.g., methylene chloride) for at least 12 hours. The extract is transferred to a large vessel suited for solvent evaporation, and then the PE is re-extracted three more times with methylene chloride, with the extracts combined for evaporative concentration and eventual GCMS (or suitable) instrumental analysis. After extraction, the PE is air-dried and weighed.
- 2.2 A shaker table or some other suitable mechanical agitation is recommended for the extractions to facilitate PE-solvent contact.

3.0 INTERFERENCES

- 3.1 PE is susceptible to contamination from atmospheric and surfaces, and so it must be handled using clean techniques.
- 3.2 While the formation of biofilms and epiphytic growth on PE surfaces does not compromise their behavior in the field during deployment, these coatings can substantially complicate subsequent chemical analysis. Careful removal of adhering sediment or surface growths via water-wetted Kimwipe[®] wiping may be necessary. Surface coatings of organic films on PE (e.g., oil or tar residues) can be removed by using solvent-saturated wipes (<minute contact times) followed by immediate Surrogate standard addition and solvent extraction.

4.0 APPARATUS AND MATERIALS

- 4.1 Extraction vessels: amber glass vials (foil-lined lids)
- 4.2 Concentrating vessels: 100 mL glass, pear-shaped flask with glass stopper; 250 mL glass, round-bottom flask with glass stopper or equivalent

- 4.3 Bottle/jar tumbler, shaker table, bottle roller or equivalent
- 4.4 Analytical balance - capable of weighing to 0.1 mg (i.e., small value relative to samplers weights that are typically between 10 and 100 mg.)
- 4.5 Food-grade aluminum foil
- 4.6 Stainless steel forceps
- 4.7 Single-edge razor blades
- 4.8 Teflon (or similar non-contaminating material) cutting board
- 4.9 Glass transfer pipettes.
- 4.10 Kimberly-Clark Kimwipe[®] or equivalent

5.0 REAGENTS

- 5.1 Methylene chloride, CH₂Cl₂, pesticide grad or equivalent (other solvent suited to analytes of interest).
- 5.2 Organic-free reagent water (as defined in SW-846 Chapter One)
- 5.3 Research grade surrogate and injection standard compounds certified >98+% pure or equivalent.

6.0 PREPARATION AND HANDLING

- 6.1 Upon recovery and return to a clean working environment, the PE should be surface cleaned prior to any cutting or extraction. The PE surface should be wiped and rinsed free of surface particles and coatings. This may include briefly (< minute) wiping with a hexane-soaked Kimwipe[®] (or equivalent) to remove oily or tarry exterior staining. If water wet, the PE surface should be blotted dry with a clean wipe.
- 6.2 Laboratory and field personnel should wear nitrile or latex gloves whenever handling PE to avoid cross-contaminating the PE.
- 6.3 Methylene chloride (pesticide grade) rinsed, stainless steel forceps and scissors are used when manipulation of PE is required.
- 6.4 Clean aluminum foil is used to cover any surface that PE may encounter.

7.0 PROCEDURE

- 7.1 Solvent Extraction: Laboratory and/or field blank and field-exposed PE is spiked with known quantities of surrogate compounds to assess analytical recoveries and extracted using organic solvents prior to analysis by GC/MS.
 - 7.1.1 The PE is inspected for surface biofilms, particles, mud, or oily coatings. Biofilm mass **should be removed by using a clean wipe followed by a rinse with organic-free reagent water. Particles and sedimentary debris are removed by rinsing with organic-free reagent water and careful surface scraping if necessary to remove adhered/imbedded material. Oily coatings (e.g., coal tar**

staining or hydrocarbon slicks) are removed by soaking clean wipes in hexane and using forceps to hold and wipe both PE surfaces. This is not an exhaustive extraction and should be done quickly (<minute) and immediately prior to immersion in solvent. PE surfaces are blotted dry if water wet.

- 7.1.2 The PE is transferred to a pre-cleaned amber vial (size determined by dimensions of PE, typically 15-40mL). Vial must be large enough for complete immersion of PE without excessive PE folding.
 - 7.1.3 Known masses of surrogate compounds (Appendix 1) in a methylene chloride-compatible solvent are added to the vial. Typical additions are: 2.5-20 ng for aqueous samples; 50-250 ng for sediment samples, depending on target HOCs and their expected concentrations in the PE.
 - 7.1.4 Methylene chloride is added to the vial to completely submerge the PE for a period of at least 12 hours.
 - 7.1.5 The extract is transferred to a pre-cleaned glass concentration vessel. A second aliquot of methylene chloride is added to the extraction vial and agitated for >10 minutes. This step is repeated two more times.
 - 7.1.6 After the final extract transfer, the PE is allowed to air dry in the extraction vial and weighed on an analytical balance until a consistent PE mass is obtained. This result is used to calculate the final target HOC concentrations measured in the PE sampler in units of HOC mass per PE mass.
- 7.2 Extracts are concentrated using rotary evaporation (or equivalent) down to suitable volumes for GCMS analysis; the resultant concentrated extracts are transferred to smaller vials (e.g., for autosamplers) according to standard laboratory practices. Before analysis, appropriate injection standards are added to the final extracts to allow for evaluation of the total volume of extract analyzed (Appendix 1).

Typical final extract volumes are:

50-250 µL for water column-exposed PE

1-10 L for contaminated sediment bed-exposed PE

8.0 QUALITY CONTROL

- 8.1 Method blanks, field blanks, matrix spikes, and/or replicate samples should be subjected to exactly the same analytical procedures as those used on field/lab-exposed samples.
- 8.2 QA/QC metrics, that are specific to the type of target HOCs of interest and the analytical methods used to quantify them, should be applied. Typical values for targets like PAHs and PCBs that are analyzed by capillary gas chromatography-low resolution mass spectrometry, in which picogram/uL detection is common, are:
 - 8.2.1 Freshly prepared polyethylene and trip blanks: <0.1 ng / g PE
Freshly cleaned PE samples, and samples of PE that traveled to and from the field site ("trip blank"), should have no significant

peaks where PRCs, surrogate standards, injection standards, and target analytes elute.

- 8.2.2 PRC-loaded polyethylene reproducibility ($\pm 1\sigma/\text{mean}$, N=6): <10%
Individual batches of PE loaded with PRCs should exhibit reproducible PRC concentrations in the PE before deployment.
- 8.2.3 Recoveries of Surrogate Standards: >70% to < 120%
Surrogate standards should be recovered from PE samples at 100%, plus or minus analytical precision. An exception may be relatively volatile compounds (e.g., mono-, di-chlorobiphenyls) that may be significantly lost when extracts are evaporated (e.g., recovery down to 60%).
- 8.2.4 Precision of replicate PE extract analyses (N \geq 3): <20%.
The reproducibility of all analytes (injection standards, surrogate standards, PRCs, and target compounds) determined with multiple instrumental analyses of the same PE sample extract, even run on different dates, should fall with suitably narrow bounds.
- 8.2.5 Detection limits using PE samples: <1 ng / g PE
Assuming 100 mg PE samples and 100 uL final extract volumes, target analytes such as PAHs and PCBs analyzed by GCMS (or methods with like sensitivity) should have <ppb detection limits.

9.0 METHOD PERFORMANCE

- 9.1 The method performance is assessed by determining the recovery and reproducibility in analyzing surrogate compounds (Appendix 1). All other lab-specific QA/QC metrics should be adhered to.
- 9.2 Successful PE deployment is achieved when significant (>method precision) losses of PRCs occurred, allowing one to use their behavior to adjust target compound levels in the PE up to equilibrium concentrations (Fernandez et al. 2009).

10.0 REFERENCES

Fernandez L.A., Harvey, C.F., and Gschwend, P.M. Using performance reference compounds in polyethylene passive samplers to deduce sediment pore water concentrations for numerous target chemicals. Environ. Sci. Technol., 43, 8888-8894, 2009.

Appendix 1 Suggested Performance Reference Compounds (PRCs), Surrogate Compounds (Recovery Standards), and Injection Standards. The lab preparing the PEDs must coordinate PRC choices with the lab doing the PE analyses to avoid conflicting uses.

A. PRCs, suitable for polycyclic aromatic hydrocarbon (PAH) determinations when Capillary Gas Chromatography-Mass Spectrometry (GCMS) is used for analysis include, but are not restricted to, deuterated PAHs. One subset should be used as PRCs, while reserving others

for use as surrogate (recovery) and injection standards. Unlabeled compounds such as terphenyl can be used as injection standards if they are readily resolved from the other analytes.

Targets: PAHs	Method: GCMS			Detection Limit ~ 100 pg / 100 mg PE		
PRCs	d10-phenanthrene	d10-pyrene	d12-chrysene			
Surrogates	d10-anthracene	d10-fluoranthene	d12-benz(a)anthracene			
Injection Standards	d10-acenaphthene	d14- <i>m</i> -terphenyl	d12-perylene			

B. PRCs and surrogate compounds suitable for polychlorinated biphenyl (PCB) determinations when GCMS is the method separation and detection include, but are not restricted to, ¹³C-labeled or deuterated PCB congeners. One subset, for example including tri-, tetra-, penta-, hexa-, and heptachloro-biphenyls, can be used as PRCs while reserving different tri-, tetra-, penta-, hexa-, and heptachloro-biphenyl congeners to serve as surrogate compounds. Still other compounds such as deuterated PAHs or rare PCBs (not contained in Aroclor/Clophan mixtures such as: PCB-39, PCB-55, PCB-104, PCB-150 and PCB-188) can be used as injection standards.

Targets: PCBs	Method: GCMS						Detection Limit ~ 100 pg / 100 mg PE					
PRCs	¹³ C PCB-28	¹³ C PCB-52	¹³ C PCB-101	¹³ C PCB-153	¹³ C PCB-180							
Surrogates	¹³ C PCB-19	d ₆ PCB-77	¹³ C PCB-105	¹³ C PCB-167	¹³ C PCB-170	¹³ C PCB-194						
Injection Standards	d17-39	d22-104	d34-55	d40-150	d52-188							

C. When analyzing for organochlorine pesticides such as DDT using GCMS, ¹³C labeled compounds can serve as PRCs. However, since DDT has been seen to degrade to form DDE or DDD in certain situations, one should use the 4,4'- isomer of DDT and the 2,4'-isomers of DDE and DDD as PRCs to allow appearance of ¹³C-labeled 4,4'-DDE or 4,4'-DDD to be interpreted as arising from reaction of the DDT PRC during the deployment. Deuterated or ¹³C labeled PCBs can be used as surrogate (recovery) and injection standards.

Targets: DDTs	Method: GCMS		Detection Limit ~ 200 pg / 100 mg PE	
PRCs	¹³ C 2,4'-DDE	¹³ C 2,4'-DDD	¹³ C 4,4'-DDT	
Surrogates	¹³ C-PCB111	¹³ C-PCB153	¹³ C PCB 178	
Injection Standards	d6 PCB 77	¹³ C PCB 105	¹³ C PCB 167	

Appendix C. Seasonal variations in groundwater pumping near Pegan Cove in 2010 and 2011.

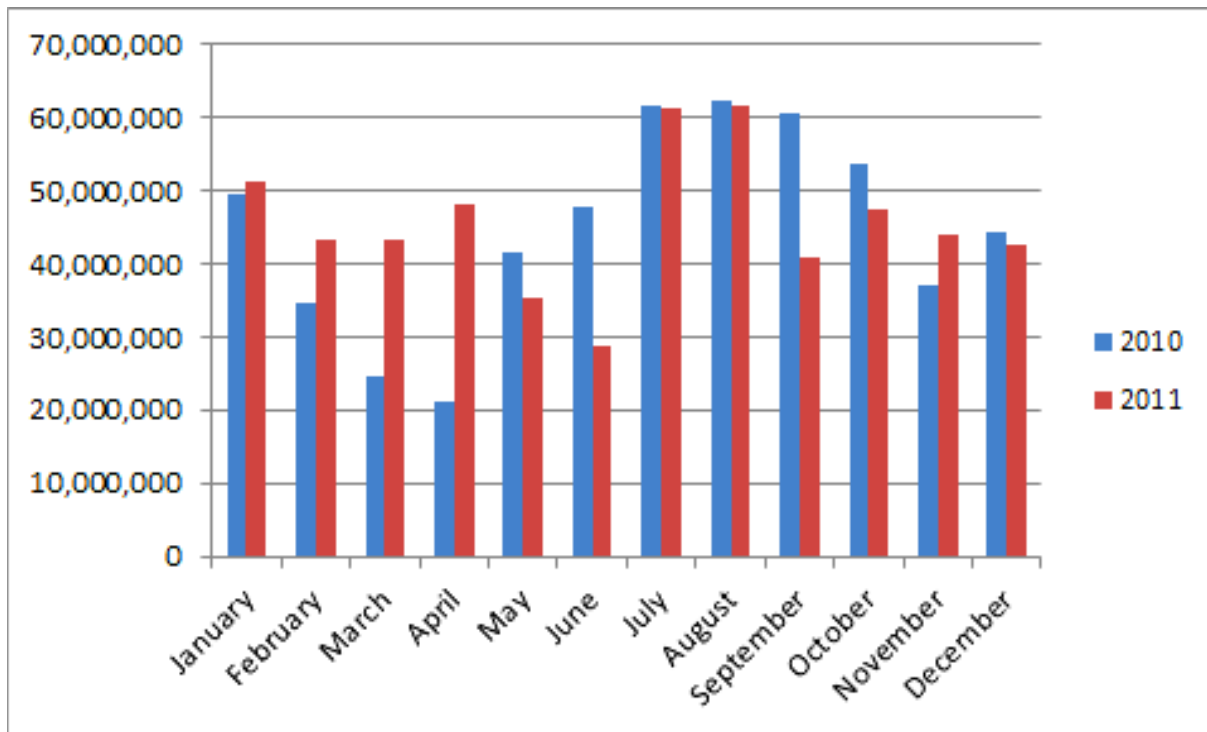

Appendix D. Station Locations.

Site_ID	latitude (North)	longitude (West)
ESTCP-001	42.2861152	71.3595556
ESTCP-002	42.2862694	71.3601332
ESTCP-003	42.2870016	71.3600303
ESTCP-004	42.2874137	71.3607853
ESTCP-005	42.2881314	71.3604179
ESTCP-006	42.2887066	71.3609393
ESTCP-007	42.2882916	71.3588126
ESTCP-008	42.2887894	71.3576087
ESTCP-009	42.2893199	71.3588111
ESTCP-010	42.2899558	71.3592531

ESTCP-011	42.28882809620	71.3609402381
ESTCP-012	42.29007833080	71.3571051748
ESTCP-013	42.28878943390	71.3576087222
ESTCP-014	42.28790530340	71.3576884006
ESTCP-015	42.28603774660	71.3585545911
ESTCP-016	42.28689635600	71.3590243508
ESTCP-017	42.28796231240	71.3605950132
ESTCP-018	42.28787998980	71.3605951944
ESTCP-019	42.28796217780	71.3604841411
ESTCP-020	42.28787728360	71.3604884458

ESTCP-021	42.28978354	71.35972689
ESTCP-022	42.289782765	71.35909637
ESTCP-023	42.28978199	71.35846585
ESTCP-024	42.28978121	71.35783532
ESTCP-025	42.2887852	71.36049759
ESTCP-026	42.2887845	71.3599277
ESTCP-027	42.28878381	71.35935782
ESTCP-028	42.28878311	71.35878793
ESTCP-029	42.28878241	71.35821804
ESTCP-030	42.288781702	71.35764815
ESTCP-031	42.287800877	71.36042471
ESTCP-032	42.287800198	71.35986696
ESTCP-033	42.287799516	71.35930921
ESTCP-034	42.287798831	71.35875145
ESTCP-035	42.287798144	71.3581937
ESTCP-036	42.287004249	71.35979933
ESTCP-037	42.287003419	71.35912081
ESTCP-038	42.287002585	71.35844181
ESTCP-039	42.286514770	71.35885203
ESTCP-040	42.286514113	71.35831853

Appendix D (continued). Station Locations.

Site_ID	latitude (North)	longitude (West)
ESTCP-041	42.289279957	71.359173076
ESTCP-042	42.289279287	71.35862744
ESTCP-043	42.288781349	71.35736394
ESTCP-044	42.288293466	71.36081507
ESTCP-045	42.288292133	71.35971953
ESTCP-046	42.288290795	71.35862787
ESTCP-047	42.288289925	71.35792281
ESTCP-048	42.287801219	71.36070705
ESTCP-049	42.287807155	71.35931712
ESTCP-050	42.287371366	71.36060168
ESTCP-051	42.287370348	71.35976505
ESTCP-052	42.287369324	71.35892843
ESTCP-053	42.287368299	71.35809677
ESTCP-054	42.286892665	71.36027785
ESTCP-055	42.287002482	71.35805621
ESTCP-056	42.286637991	71.35978388
ESTCP-057	42.286729409	71.35867153
ESTCP-058	42.286513865	71.35811695
ESTCP-059	42.286073714	71.35967272
ESTCP-060	42.286072582	71.35874922
ESTCP-061	42.2888280962	71.3609402381
ESTCP-062	42.2900783308	71.3571051748
ESTCP-063	42.2860377466	71.3585545911
ESTCP-064	42.28978354	71.35972689
ESTCP-065	42.28978354	71.35972689
ESTCP-066	42.28978354	71.35972689
ESTCP-067	42.28978354	71.35972689
ESTCP-068	42.28978354	71.35972689
ESTCP-069	42.287799584	71.35936498
ESTCP-070	42.2860377466	71.3585545911
ESTCP-071	42.28737103	71.36032735
ESTCP-072	42.28737069	71.36004847
ESTCP-073	42.2864136	71.36011314
ESTCP-074	42.28882809620	71.3609402381
ESTCP-075	42.29007833080	71.3571051748
ESTCP-076	42.28603774660	71.3585545911
ESTCP-077	42.28878311	71.35878793
ESTCP-078	42.288781349	71.35736394
ESTCP-079	42.287371366	71.36060168

Appendix E. Organic carbon (f_{oc}) and black carbon (f_{bc}) weight percent results for sediments recovered in the first sampling round. f_{oc} values averaged near 14% by weight and black carbon contents averaged 1% by weight.

	foc (%)	fbc (%)	bc/oc
site 1	14	2.1	0.16
site 2	0.6	0.02	0.04
site 3	16	1.3	0.08
site 4	1.3	0.1	0.09
site 5	19	1.3	0.07
site 6	4.6	0.1	0.02
site 7	22	1.7	0.08
site 8	14	1.2	0.08
site 9	29	1.5	0.05
site 10	15	1.4	0.09
ave first 10 sites	13.5	1.1	0.08
std deviation	9.0	0.7	0.04

Appendix F. Minimum detection limits for five individual PCB congeners (#28, 52, 101, 153, and 180) determined by analyzing low levels in 10 PE strips. Assuming PE strip mass is 100 mg, the extract volume is 100 uL, and using PE-water partition coefficients from Lohmann (2012), these results imply porewater detections are below 1 pg/L for individual congeners if the PE is equilibrated with the porewater; more uncertainty associated with PRC corrections will cause these minimum detection limits to go up for *in situ* deployments where PE-porewater equilibration cannot be assumed.

congener no.	average (picograms) of 10 PE analyses	1 sigma mass uncertainty	MDL/injection	if extract volume 100 uL and PE mass 100 mg	with log K _{pew} (Lohmann review)	C _{porewater} MDL
			= t*sigma t with N=9 2.821 in pg/injection			
d13-28	0.33	0.067	0.19	0.19 ng/g PE	5.4	0.75
d19-52	0.37	0.044	0.12	0.12	5.7	0.25
d38-101	0.44	0.129	0.36	0.36	6.3	0.18
d54-153	0.37	0.108	0.31	0.31	6.8	0.05
d72-180	0.38	0.159	0.45	0.45	7.1	0.04

Appendix G. Comparisons of Pace and MIT measures of four PCB congeners (52, 101, 153, and 180) in sediments from two sites in Pegan Cove (stations 1 and 8) after spiking at four different levels.

test: $is (meanPace - meanMIT) > \pm t * 0.3 * \sqrt{(Pace * MIT) / \sqrt{(N1N2 / (N1 + N2))}}$
 assuming 30% RSD and geom mean results

congener #52 #101 #153 #180
yes: 8/8 2/8 2/8 0/8

		Pace				MIT					
		ng/g PE				ng/g PE					
station	spike (ug)	52	101	153	180	52	101	153	180		
MIT minus Pace for each congener											
$t * \text{std dev} / \sqrt{(n1 * n2 / (n1 + n2))}$											
<i>MIT means from values listed elsewhere.</i>											
station 1											
1S1A2	250	49.4	184.2	462.5	252.6						
1S1C3	250	43.6	186.2	419.7	216.4						
	averages	46.5	185.2	441.1	234.5	84.9	165.3	384.4	180.7		
	N=2,8					1.83	0.89	0.87	0.77		
1S2B2	25	50.1	134.9	148.0	131.6	38.40	-19.92	-56.73	-53.81		
1S2D3	25	29.9	84.2	190.1	97.4	34.4	95.7	225.2	112.6		
	averages	40.0	109.5	169.1	114.5	95.2	143.4	286.4	115.4		
	N=2,10					2.38	1.31	1.69	1.01		
1S3A1	2500	40.2	560.5	1736.8	1072.4	55.26	33.88	117.37	0.91		
1S3O2 (=	2500	78.3	386.8	526.3	596.7	31.9	64.9	113.9	59.5		
	averages	59.2	473.7	1131.6	834.5	134.3	568.5	1374.6	729.0		
	N=2,9					2.27	1.20	1.21	0.87		
1S4B1	0	32.5	82.9	180.9	95.4	75.06	94.84	243.01	-105.53		
1S4C1	0	30.3	102.0	234.2	119.1	48.2	280.6	674.5	421.8		
	averages	31.4	92.4	207.6	107.2	86.3	122.2	256.8	101.6		
	N=2,10					2.75	1.32	1.24	0.95		
station 8						54.88	29.73	49.20	-5.61		
						26.9	55.0	119.5	54.0		
8S1A3	25	59.5	89.5	134.9	70.4						
8S1D1	25	61.4	80.3	106.6	62.8						
	averages	60.5	84.9	120.7	66.6	133.0	117.6	138.0	54.7		
	N=2,8					2.20	1.39	1.14	0.82		
8S2A2	0	59.3	89.5	127.6	73.7	72.51	32.68	17.31	-11.92		
8S2C3	0	40.2	58.9	76.3	43.6	49.0	54.6	70.6	33.0		
	averages	49.8	74.2	102.0	58.6	210.4	170.0	178.5	74.8		
	N=2,10					4.23	2.29	1.75	1.28		
8S3C2	250	72.4	121.7	233.6	154.6	160.65	95.80	76.54	16.15		
8S3D3	250	67.8	139.5	244.1	161.8	53.0	58.2	69.9	34.3		
	averages	70.1	130.6	238.8	158.2	165.9	184.9	278.3	141.4		
	N=2,8					2.37	1.42	1.17	0.89		
8S4B2	2500	96.1	478.9	1282.9	1046.1	95.81	54.27	39.46	-16.79		
8S4D2	2500	56.4	453.9	1460.5	1236.8	59.0	85.0	141.0	81.8		
	averages	76.2	466.4	1371.7	1141.4	224.9	834.5	1856.7	1076.1		
	N=2,9					2.95	1.79	1.35	0.94		
						148.69	368.05	484.99	-65.34		
						70.8	337.4	863.1	599.4		
						(Pace-MIT)/(Pace*MIT)^0.5	average	2.6	1.5	1.3	0.9
						stdev	0.73	0.42	0.29	0.15	

Appendix H. Detailed Cost Comparison of PE Sampling versus Traditional Ponar Dredge Sampling Techniques.

The following tables show (a) costs used for field sampling expendibles, (b) costs associated with non-expendible materials, (c) sample shipping and field labor costs, and (d) analysis costs to determine PCBs in the polyethylene.

Cost Element	PE Sampling Technique	Ponar Dredge Sampling Technique	Unit	Unit Cost	PE Sampling Technique	Ponar Dredge Sampling Technique
	Quantity	Quantity			Total	Total
FIELD SAMPLING COSTS						
Expendables						
Stainless Steel Mixing Bowls	0	2	ea.	\$12.97	\$0.00	\$25.94
Stainless Steel Spoons	0	2	ea.	\$2.97	\$0.00	\$5.94
5-Gallon Plastic Buckets	0	2	ea.	\$2.60	\$0.00	\$5.20
Plastic Scrub Brush	0	1	ea.	\$6.99	\$0.00	\$6.99
Liquinox	0	0.5	pint	\$8.99	\$0.00	\$4.50
Nitrile Gloves	0.25	1	box	\$12.00	\$3.00	\$12.00
Aluminum Foil	4	1	roll	\$3.99	\$15.96	\$3.99
Distilled Water	1	4	gal.	\$2.50	\$2.50	\$10.00
Plastic Bubble Wrap	0	0.2	box	\$18.00	\$0.00	\$3.60
Paper Towels	1	3	roll	\$0.79	\$0.79	\$2.37
Ice (for sample shipment)	0	5	bag	\$3.00	\$0.00	\$15.00
Garbage Bag Disposal	1	3	ea.	\$15.00	\$15.00	\$45.00
Zip Lock Bags (ice)	0	4	ea.	\$0.30	\$0.00	\$1.20
Plastic Sheeting	0	0.25	roll	\$40.00	\$0.00	\$10.00
Nylon Rope (1/2")	0	30	ft.	\$0.58	\$0.00	\$17.40
Subtotal					\$37.25	\$169.13
% Savings of PE Technique						78%^d

Cost Element	PE Sampling Technique	Ponar Dredge Sampling Technique	Unit	Unit Cost	PE Sampling Technique	Ponar Dredge Sampling Technique
	Quantity	Quantity			Total	Total
Non-Expendables						
Handheld GPS (rental)	1	1	per day	\$20.00	\$20.00	\$20.00
Vehicle (rental)	2	2	per day	\$65.00	\$130.00	\$130.00
3" Polycarbonate Tubing	0	0	ft.	\$19.09	\$0.00	\$0.00
4" Polycarbonate Tubing	0	0	ft.	\$14.55	\$0.00	\$0.00
6" Polycarbonate Tubing	0	0	ft.	\$28.80	\$0.00	\$0.00
3" Quick Caps	0	0	ea.	\$7.46	\$0.00	\$0.00
4" Quick Caps	0	0	ea.	\$9.13	\$0.00	\$0.00
6" Quick Caps	0	0	ea.	\$12.46	\$0.00	\$0.00
Ponar Dredge 6" x 6"	0	1	ea.	\$810.00	\$0.00	\$810.00
Ponar Dredge 6" x 6" (rental)	0	0	per day	\$20.00	\$0.00	\$0.00
Ponar Dredge 9" x 9" (rental)	0	0	per day	\$30.00	\$0.00	\$0.00
Eckman Dredge 6" x 6"	0	0	ea.	\$580.00	\$0.00	\$0.00
Eckman Dredge 6" x 6" (rental)	0	0	per day	\$20.00	\$0.00	\$0.00
Eckman Dredge 9" x 9"	0	0	per day	\$30.00	\$0.00	\$0.00
Toggle Clamp Bracket	1	0	ea.	\$41.00	\$41.00	\$0.00
1/2" Black Steel Pipe	15	0	ft.	\$2.47	\$37.05	\$0.00
1/2" Black Steel Couplings	1	0	ea.	\$3.94	\$3.94	\$0.00
1/2" Black Steel Tee	1	0	ea.	\$3.14	\$3.14	\$0.00
Sink Rope (1/4" Hotshot Med White)	1200	0	ft.	\$0.06	\$72.00	\$0.00
PED Aluminum Frames	12	0	ea.	\$30.00	\$360.00	\$0.00
PED Frame Hardware						
HEX Screws (#8x3/8") zinc plated	60	0	ea.	\$1.18	\$70.80	\$0.00
Machine Screws (1/4"-20 x 1/2")	72	0	ea.	\$0.07	\$5.04	\$0.00
Cut Washer (3/8" zinc plated)	72	0	ea.	\$1.18	\$84.96	\$0.00
Cap Nut (1/4" zinc plated)	72	0	ea.	\$1.18	\$84.96	\$0.00
Spring Links (Carabiners)	36	0	ea.	\$0.98	\$35.28	\$0.00
				Subtotal	\$948.17	\$960.00
				% Savings of PE Technique		1%

Cost Element	PE Sampling Technique	Ponar Dredge Sampling Technique	Unit	Unit Cost	PE Sampling Technique	Ponar Dredge Sampling Technique
	Quantity	Quantity			Total	Total
Sample Shipment						
Clear Packing Tape	0.25	0.25	roll	\$3.97	\$0.99	\$0.99
Duct Tape	0.25	0.5	roll	\$3.34	\$0.84	\$1.67
Fed Ex (MA to MN)	1	0	10 pound	\$102.36	\$102.36	\$0.00
Fed Ex (MA to MN)	0	1	40 pound	\$240.35	\$0.00	\$240.35
				Subtotal	\$104.19	\$243.01
				% Savings of PE Technique		57%
Field Labor						
Field Technician I	10	12	hr.	\$45.00	\$450.00	\$540.00
Field Technician II	10	12	hr.	\$65.00	\$650.00	\$780.00
Equipment Manager	4	6	hr.	\$35.00	\$140.00	\$210.00
				Subtotal	\$1,240.00	\$1,530.00
				% Savings of PE Technique		19%
TOTAL FIELD SAMPLING COSTS				Total	\$2,330	\$2,902
				% Savings of PE Technique		20%

Cost Element	PE Sampling Technique	Ponar Dredge Sampling Technique	Unit	Unit Cost	PE Sampling Technique	Ponar Dredge Sampling Technique
	Quantity	Quantity			Total	Total
ANALYTICAL COSTS						
PCB Analysis (1668A) - Sediment	12	0	per sample	\$840.00	\$10,080.00	\$0.00
PCB Analysis (1668A) - PE	0	12	per sample	\$840.00	\$0.00	\$10,080.00
PE Preparation (supplies - PE strips, solvents, labeled PRCs, surrogates, glassware, nitrogen)	12	0	per sample	\$62.00	\$744.00	\$0.00
PE Preparation (labor for cutting, cleaning, and PRC loading)	1.5	0	hr.	\$65.00	\$97.50	\$0.00
PRC Corrections	1	0	hr.	\$100.00	\$100.00	\$0.00
Total Analytical Costs				Total	\$11,021.50	\$10,080.00
				% Savings of PE Technique		-9.3%

- 2 people sampling sediment from 12 locations from a small boat using a ponar dredge.
- 2 people installing PEDs at 12 locations from a small boat.
- PEDs will require 2 field deployments, while traditional sediment sampling requires 1 deployment.
- 4 hours to install 12 PEDs and 4 hours to retrieve and pack for shipment 12 PEDs.
- PEDs can be installed in either a straight line or randomly within lake
- 100 feet of sink rope used per PED
- PEDs assembled by equipment manager and not by laboratory.
- Cost includes initial cost for PED frames and hardware. A rental charge can be calculated at a later time.
- Ponar dredge purchase cost used in calculation to be comparable to PED frame purchase cost.